

Film-Tech

The information contained in this Adobe Acrobat pdf file is provided at your own risk and good judgment.

These manuals are designed to facilitate the exchange of information related to cinema projection and film handling, with no warranties nor obligations from the authors, for qualified field service engineers.

If you are not a qualified technician, please make no adjustments to anything you may read about in these Adobe manual downloads

www.film-tech.com

Ultra★Phonic

INFRARED HEADPHONE TRANSMISSION SYSTEMS

UPC-1
UPC-2

INSTRUCTION MANUAL



Quality Cinema Products

Ultra★Stereo Labs, Inc. • 181 Bonetti Drive
San Luis Obispo, CA 93401

Telephone 805.549.0161 • FAX 805.549.0163
www.usl.com • e-mail usl@uslinc.com

One Year Limited Warranty



Ultra Stereo Labs warrants that each product manufactured by it will be free from defects in material and workmanship under normal usage for a period of one year after its purchase new from an authorized dealer. Our obligation under this warranty is limited to repairing or replacing any product or component which we are satisfied does not conform with the foregoing warranty and which is returned to our factory, freight paid, or serviced by one of our authorized contractors. The Foregoing Warranty is Exclusive And in Lieu of All Other Warranties, Whether Expressed or Implied. Such warranty shall not apply to any product or component (A) repaired or altered by anyone other than Ultra* Stereo Labs or an authorized service contractor; (B) tampered with or altered in any way or subjected to misuse, negligence or accident or (C) which has been improperly connected, installed or adjusted otherwise than in accordance with Ultra* Stereo Labs instruction.*

Ultra★Phonic

INFRARED HEADPHONE TRANSMISSION SYSTEMS

The **Ultra★Phonic Infrared Headphone Transmission System** is designed to provide intelligible, clear sound for your hearing-impaired customers.

Meets CE Approval Standards

TABLE OF CONTENTS

UPC FEATURES	4
UPC-1/UPC-2 INSTALLATION	5
UPC-1 with IRI-10 SPEAKER BIAMP BOARD	10
FACTS ABOUT INFRARED TRANSMISSION SYSTEMS	11
Illustrations:	
UPC FEATURES	4
UPC-1 AUDIO, POWER CONNECTIONS	6
SUMMING RESISTOR NETWORK	6
UPC-2 AUDIO, POWER CONNECTIONS	7
DIODE LIFE EXPECTANCY CHART	9
FRONT AND REAR MOUNTED VIEWS	9
UPC-1 with IRI-10 SPEAKER BIAMP BOARD	10

UPC FEATURES

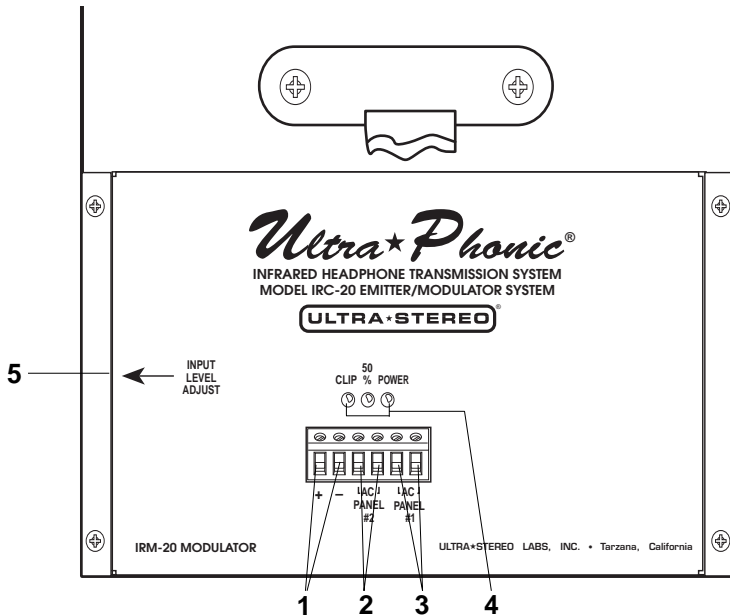

Fig. A – Rear view of the IRC-20 showing connections and indicators

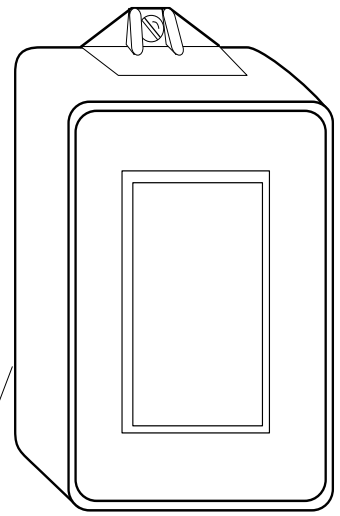

Fig. B – IRP-20 AC Power Pack

1. AUDIO INPUT TERMINALS

The IRC-20 will accept an audio signal level from 100 mv to greater than 30 V rms.

2. AC PANEL #2

Connects to the 24 V AC Power Pack supplied with the IRC-20. For use only with two-panel systems. See page 7.

3. AC PANEL #1

Connects to the 24 V AC Power Pack supplied with the IRC-20. See page 6.

WARNING! Use only the AC Power Pack supplied with the IRC-20 or else permanent damage to the unit may result.

4. LED INDICATORS

From left to right, the 'CLIP' LED illuminates when the input level overloads the IRC-20. The '50%' LED indicates that the input level reaches 50% modulation. It will just illuminate when the input level is correctly set. The 'POWER' LED indicates that the unit is on.

5. INPUT LEVEL TRIMPOT

This 15-turn trimpot adjusts the input signal level.

6. 24 V AC IRP-20

Connect to the AC PANEL #1 terminals. If you have a two-panel system, you need two power packs.

Newer transformers have a resetting fuse in the form of an internal poly switch. In this instance, an external fuse is not required.

UPC-1/UPC-2 INSTALLATION

UNPACK THE BOX AND VERIFY THAT ALL SHIPPING MATERIALS ARE PRESENT.

There should be:

FOR THE UPC-1 System Package

- One (1) System Manual
- One (1) IRC-20 Emitter/Modulator Unit
- One (1) IRP-20 AC Power Pack
- One (1) Mount Bracket
- Two (2) 10-32 X 5/8" machine screws for attaching the emitter to the mount bracket.

FOR THE UPC-2 System Package

- One (1) System Manual
- One (1) IRC-20 Emitter/Modulator Unit
- One (1) IRE-10 Emitter Panel
- Two (2) IRP-20 AC Power Packs
- One (1) Mount Bracket
- One (1) IRBS-20 Bracket Strap
- Two (2) 10-32 X 5/8" machine screws for attaching the emitter to the mount bracket.

YOU WILL NEED TO SUPPLY THE FOLLOWING MATERIALS:

- A small, jeweler's type flat blade screwdriver or trim pot alignment tool for adjusting the modulator gain, and a medium head screwdriver.
- Shielded audio cable for connecting the IRC-20 modulator to the program source, with tie-wraps.
- Eighteen (18) gauge or greater two-conductor zip cord for the 24 V IRP-20 AC Power Packs. (See tables, pages 6 & 7.)
- An electric drill with bits suitable for drilling into the surface where the Emitter will be installed.
- Suitable metal or wood screws to attach the bracket to the wall.
- One (1) IRH-601 or IRH 701 Headset Receiver.
- AAA Batteries for the IR headset(s), if the type ordered does not come with its own rechargeable cell.

➤ **CONNECT THE AUDIO INPUT LINE**

Connect the Center channel speaker terminals to the + and – (ground) audio input terminals on the IRC-20 as in Fig. C. If the center channel is bi-amped, you must construct a resistor network, as in Fig. D, that sums the high and low frequency signals, then feed the output of the network to the IRC-20 audio input. You also may connect the IRC-20 to the output of a monitor or a processor.

➤ **CONNECT THE PROVIDED IRP-20 AC POWER PACK**

FOR THE UPC-1

(See Figure C)

Connect the provided IRP-20 AC Power Pack to the IRC-20 AC Panel #1 terminals using standard 18-gauge or greater zip cord. (See Table 1 for lengths.) Make sure there are no loose wire strands that could touch any nearby metal and short the Power Pack.

DO NOT SHORT THE POWER SUPPLY.

Connect the Power Pack to a 115 V AC 50/60 Hz outlet.

TABLE 1		
Maximum lengths and gauge sizes for connector cord from IRP-20 AC Power Pack to the IRC-20 AC Panel #1 terminals.		
60'	@	18 ga.
100'	@	16 ga.
150'	@	14 ga.
200'	@	12 ga.

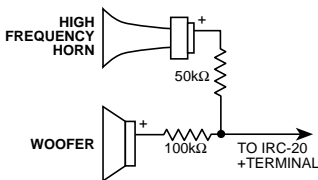

Fig. D
Summing resistor network for use with bi-amped center channel speakers

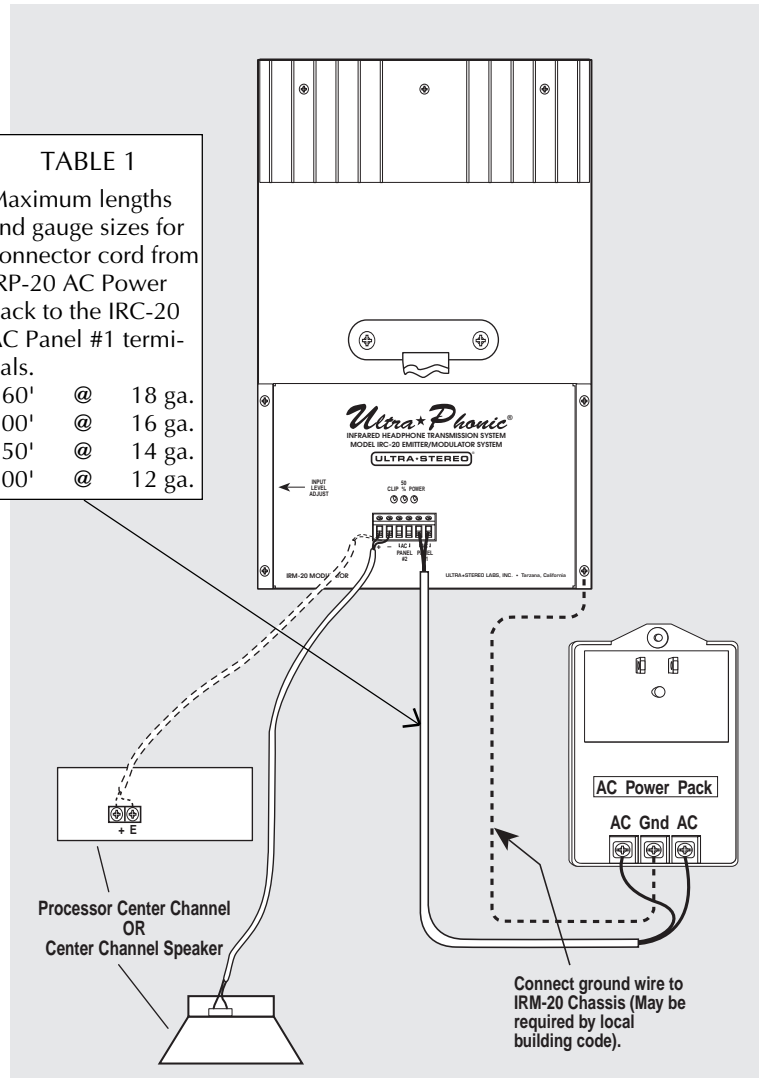

Fig. C – Connecting the audio input and 24 V AC power pack to the UPC-1 system

FOR THE UPC-2

(See Figure E) Connect one of the two IRP-20 AC Power Packs to the IRC-20 AC Panel #1 terminals, and the second IRP-20 to the AC Panel #2 terminals using standard 18-gauge or greater zip cord. (See Table 2 for lengths.) **Make sure there are no loose wire strands that could touch any nearby metal and short the Power Pack.**

DO NOT SHORT THE POWER SUPPLY.

Connect each Power Pack to a 115 V AC 50/60 Hz outlet.

TABLE 2
Maximum lengths and gauge sizes for connector cord from IRP-20 AC Power Packs to the IRC-20 AC Panel #1 and #2 terminals.

50'	@	18 ga.
70'	@	16 ga.
100'	@	14 ga.
150'	@	12 ga.

This cable must be 3-conductor.
White = H
Red = +
Black = -
See Table 2 above for maximum lengths and gauges.

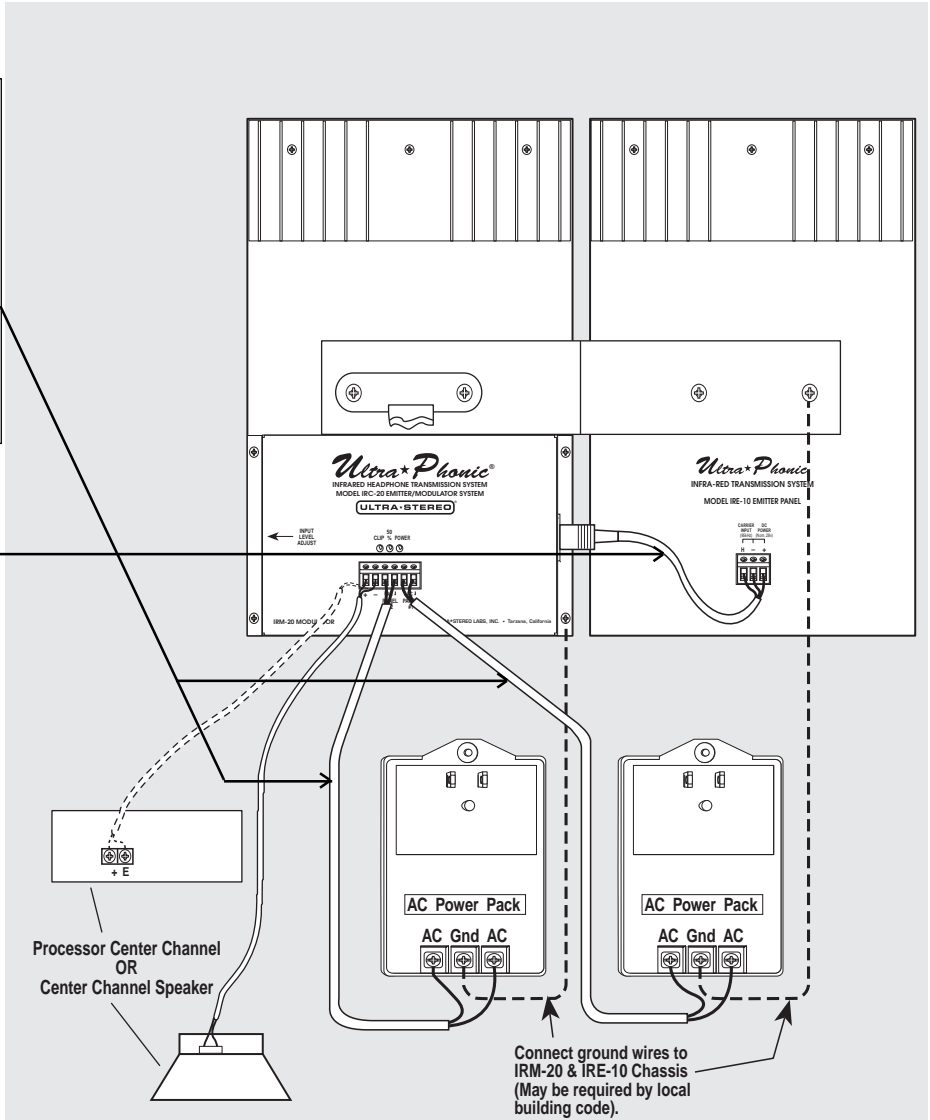

Fig. E
Connecting the audio input and both 24 V AC power packs with the UPC-2 system

► PRELIMINARY LEVEL SETTING

If the system is to be used with a cinema sound system, simply run a standard optical track 50% modulation loop in the projector (e.g., Dolby® or Ultra*Stereo®). Then adjust the IRC-20 Input Level Adjust trimpot so that as the gain is increased, the green 50% LED just comes on. This is the center LED on the IRC-20.

If the system is being used with other sources such as tape, then adjust the Input Level control so that a standard "0" reference level tape plays back so the 50% indicator light just begins to illuminate. With normal audio signal, the 50% light should flash occasionally.

Note: The IRC-20 has an automatic shutoff circuit. The unit will shut itself off after an eight-minute absence of audio signal. When the audio resumes, the panel will switch on instantly.

► MOUNTING THE EMITTER/MODULATOR AT THE FRONT OF THE AUDITORIUM

(See Figures F and G) Attach the supplied mounting bracket to the wall surface and use the supplied screws to attach the bracket to the emitter. **Allow free airflow around the emitter and be sure to have at least eight inches clearance from all surfaces, preferably more if at all possible.** The rear panel is used as a heat sink and the heat must be allowed to dissipate. Mount the emitter so that the heat sink fins are at the *top*. The unit should be mounted to the side of the screen/stage area, 12 to 15 feet above the audience's heads and pointed downward and into the seating area.

► MOUNTING THE EMITTER/MODULATOR AT THE REAR OF THE AUDITORIUM

(See Figures H and I) Attach the supplied mounting bracket to the wall surface and use the supplied screws to attach the bracket to the emitter. **Allow free airflow around the emitter and be sure to have at least eight inches clearance from all surfaces, preferably more if at all possible.** The rear panel is used as a heat sink and the heat must be allowed to dissipate. Mount the unit so that the heat sink fins are at the *top*. The emitter will cover a maximum of 5500 square feet (60' X 84') and has a primary 50° (± 25°) vertical and horizontal coverage angle, usually adequate for a 350-seat theatre. Within 30 feet of the emitter the horizontal dispersion angle of emission increases to over 140°. Within 18 feet of the emitter the vertical dispersion angle of emission increases to 80°. The emitter can be mounted 12 to 15 feet above the audience's heads. The unit can be pointed either downward into the seated area (Fig. I-A), or directly towards the screen to reflect back to the audience (Fig. I-B).

CAUTION: The rear panel may get quite warm to the touch. Power down and allow a few minutes for the surface to cool before handling the IRC-20.

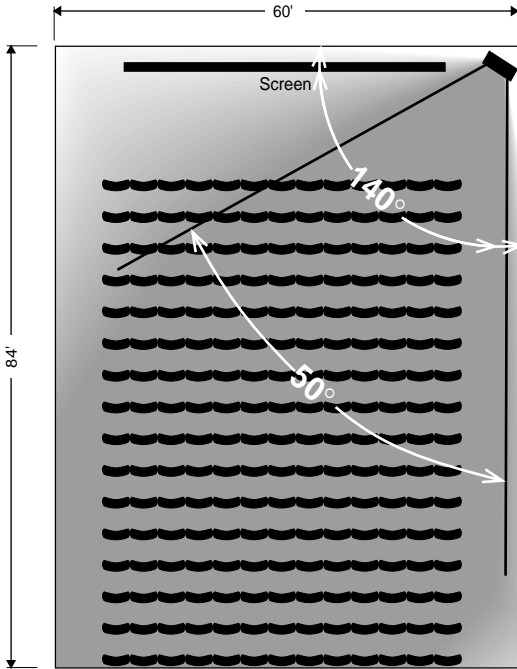

Fig. F – Front mounted emitter - top view

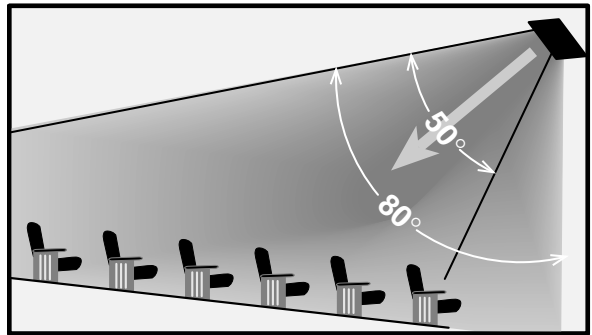
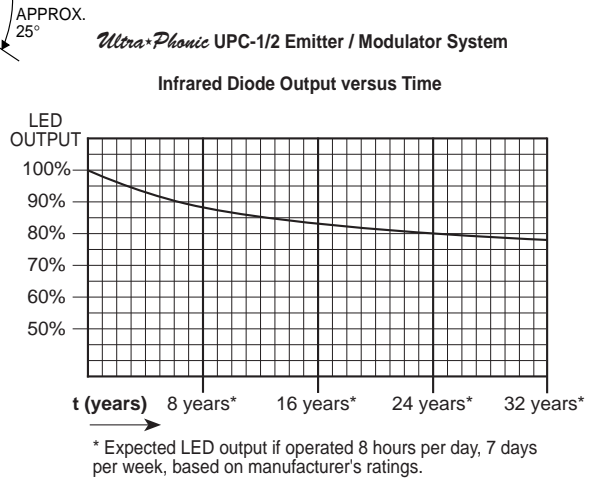

Fig. G – Front mounted emitter - side view

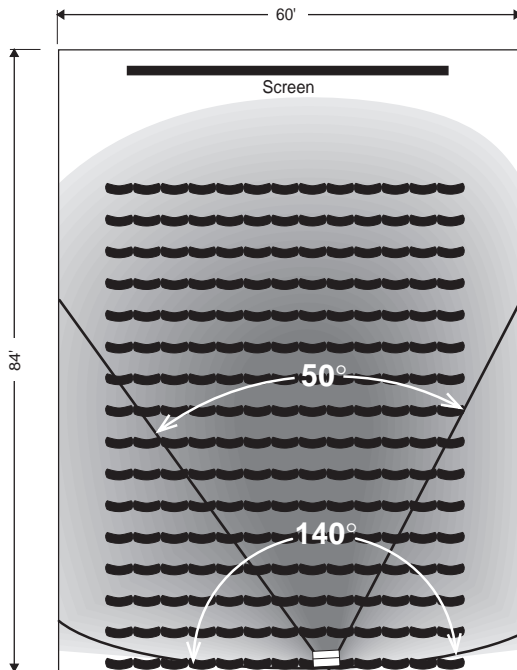

Fig. H – Rear mounted emitter - top view

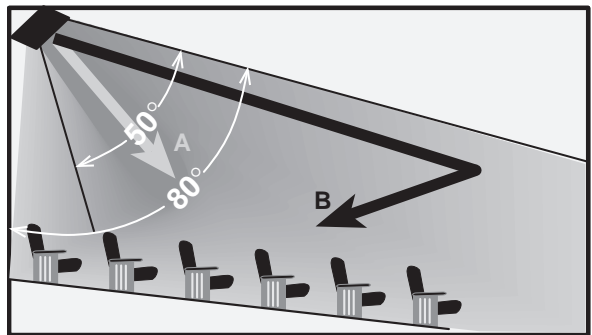
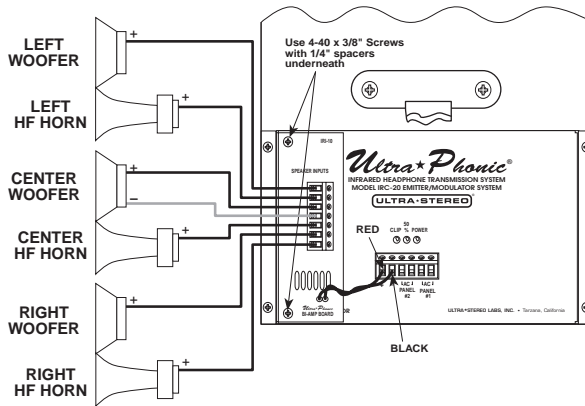

Fig. I – Rear mounted emitter - side view
(A) pointed down
(B) pointed toward screen

UPC-1 with IRI-10 Speaker Biamp Board



The IRI-10 Speaker Biamp Board accessory allows the user to connect three biamped speaker channels to the UPC-1. The three channels are mixed together with a center channel emphasis for increased speech clarity.

FACTS ABOUT INFRARED TRANSMISSION SYSTEMS

The UPC-1/UPC-2 Infrared Transmission Systems use light emitting diodes frequency modulated at 95 KHz, the international standard. All commercially available emitters and receivers will be compatible with this standard.

The modulated waves radiate from the emitter panels primarily in straight lines. Depending on the lightness of the wall color, some of this energy may be reflected and bounce around the room. Infrared energy does not penetrate walls. The modulated waves remain within the room where the emitter is placed. This feature makes it perfect for use in multiplex theatre units and for use in hotel and convention center meeting rooms and auditoriums. Additionally, this characteristic of infrared transmission makes it ideal for meetings requiring security of the signal.

USL, Inc. provides the following 95Khz headsets:

- IRH-601 – an over-the-head receiver designed with a 360° pickup.
- IRH-701 – an under-the-chin receiver with a 180° pickup.
- IRH-801 – a clip-on receiver used in connection with a neck loop or used with a cable connected to a cochlear hearing device.

Ultra★Phonic

INFRARED HEADPHONE TRANSMISSION SYSTEMS

 **USL, Inc.**

Quality Cinema Products

Ultra★Stereo Labs, Inc. • 181 Bonetti Drive
San Luis Obispo, CA 93401

Telephone 805.549.0161 • FAX 805.549.0163
www.usl.com • e-mail usl@uslinc.com