

Film-Tech

The information contained in this Adobe Acrobat pdf file is provided at your own risk and good judgment.

These manuals are designed to facilitate the exchange of information related to cinema projection and film handling, with no warranties nor obligations from the authors, for qualified field service engineers.

If you are not a qualified technician, please make no adjustments to anything you may read about in these Adobe manual downloads.

www.film-tech.com

**ALTEC
LANSING**

1698 AMPLIFIED MONITOR PANEL



DESCRIPTION

The Altec Lansing 1698 amplified monitor panel permits monitoring of seven channels, at either line level or loudspeaker level. Part of Altec's new generation of sound products, it continues the tradition of reliability and ruggedness in an attractive package.

The Altec 1698 has an amplifier section with an input isolation transformer and an input impedance of 10,000 ohms, allowing a line-bridging impedance high enough not to disturb the line

being monitored. The amplifier features an integrated circuit and a 2-watt amplifier output section plus a regulated power supply. This amplifier uses only 6 watts of line power and the power transformer will accept 120 Vac as well as 240 Vac. Line power changes are made by strapping. The 1698 can also be used with a 24-volt battery; silent and automatic transfer from ac to dc source occurs if ac line power fails. The 1698 is 3 rack units high, 5¼ inches deep, and uses an Altec Lansing 404-type loudspeaker.

SPECIFICATIONS

Type:	Amplified monitor panel	Power Required:	120/240 V A.C. 50/60 Hz, 6 watts. 24 Vdc battery operation: 10 mA at zero signal 250 mA at full power battery minus (—) is ground
Input Source:	Line or loudspeaker level, up to 7 channels	Connectors:	(1) 10 screw terminal block; (1) 5 screw terminal block; (1) 2 screw terminal block; panel mounted 3 pin XLR connector.
Input Impedance:	10 k ohm or greater	Weight:	Approximately 9 lbs.
Amplifier Power Output:	2 watts with less than 2% THD at 1000 Hz.	Color:	Black
Controls:	1 input selector 7-position rotary switch. 1 volume control with on-off switch.	Dimensions:	5¼" H x 19" W x 5" D (13.3 cm x 48.3 cm x 12.7 cm) Rack mounted.
Loudspeaker:	Altec Model 404-type		

ARCHITECT'S AND ENGINEER'S SPECIFICATIONS

The amplified monitor panel shall be mountable in a standard 19" wide equipment rack. It shall contain a 7-position input-selector switch, a volume control with on-off switch, a 3-pin, panel-mounted, XLR connector for accessory microphone connection, an amplifier section and a 4" monitor speaker. The amplifier section shall have an isolation transformer, a 2-watt power amplifier with solid-state integrated circuit and regulated power supply. The amplifier shall be capable of operation from a 120 V AC or

240 V AC, 50/60 Hz line or from a 24V battery. Line power required shall be 6 watts for full output. DC current required shall be 10 mA at zero signal and 250 mA for full output. If AC power fails, transfer to DC shall be silent and automatic.

The 4" monitor speaker shall be an Altec Model 404-type.

The amplifier monitor panel shall be the Altec Model 1698.



P.O. BOX 26105, OKLAHOMA CITY, OK 73126-0105, U.S.A.

© 1987 ALTEC LANSING CORPORATION

OPERATING INSTRUCTIONS

The 1698 Amplified Monitor Speaker Panel incorporates an integrated circuit amplifier having an output power of two watts. An isolation transformer provides a line bridging impedance of 10,000 ohms, allowing lines up to 600 ohms to be monitored without disturbance.

Seven sets of terminal connectors are supplied on the back side of the panel, permitting connection of seven monitoring channels. For the user who requires monitoring for more than seven channels, additional monitor inputs may be wired (refer to 'Monitoring Additional Channels').

A selectable 20 dB attenuator is provided to permit broad dynamic monitoring of loudspeaker lines having high or low signal level. As shipped from the factory, jumper wires bypass the attenuator to permit monitoring of low level signals to -20 dBm. To monitor high level signals and retain a flexible adjustment of the volume control, the 20 dB attenuator may be introduced into the desired circuit by cutting the associated jumper wire (refer to 'Bridging Sensitivity').

Line Power Connections

Equipment supplied for domestic use has the power transformer primary strapped for 120 volts (terminals 1 to 2, and terminals 3 and 4). The power input nameplate on the chassis, adjacent to the power cord, is mounted to show the appropriate side specifying the connection.

Battery Operation

If desired, the 1698 may be connected to an external 24-volt dc battery. Battery (-) is

ground. Terminals for the dc power connections are provided on the back of the chassis. Transfer to dc power is silent and automatic if ac power fails.

Channel Designations

For motion-picture application, monitor channels that correspond to the seven sets of terminal connectors are designated by the front panel switch for the following loudspeaker locations:

- L — left screen
- C — center screen
- R — right screen
- LEX — left extra
- REX — right extra
- LS — left surround
- RS — right surround

The channels are designated with the above abbreviations and also with numbers 1 through 7 at the terminal connectors. For those who wish to use number designations only, a self-adhesive decal is supplied. Loosen the setscrew that retains the selector switch knob and remove the knob from the shaft. Peel away the decal backing and *carefully* apply the decal to the front panel, centrally around the switch shaft, with channel 4 at the 12 o'clock position. Slip the knob on the shaft and tighten the setscrew.

Input Connections

The 1698 has a bridging input of 10,000 ohms. All inputs are balanced so that monitoring of programs for completely different systems will not cause ground loops. Polarity among channels is immaterial.

Bridging Sensitivity

A selectable 20 dB attenuator is provided to permit broad dynamic monitoring of loudspeaker lines having high or low signal level. As shipped from the factory, jumper wires bypass the attenuator to permit monitoring of low level signals.

To monitor high level signals and retain a flexible adjustment of the volume control (not always operating at the very bottom of the adjustment range), the 20 dB attenuator may be introduced into the selected circuit by cutting the associated jumper wires. Referring to the schematic diagram, the 20 dB attenuator is represented by resistors R1 and R2. Bypass jumpers are located on decks S1B and S1D of selector switch S1. Switch positions correspond to the seven channels. To modify any channel for high level signal, the corresponding switch position must be isolated (open-circuit) by cutting or re-routing the bypass path. For any channel to retain monitoring of low signal level, the bypass path of the 20 dB attenuator must be maintained. Note that any modification of deck S1B also must be accomplished for deck S1D.

This modification allows the user to monitor both inputs *and* outputs of amplifiers, delays, equalizers and other sound system equipment.

Monitoring Additional Channels

Although only seven channels are shown on the selector switch and the input terminal connectors, the switch has 12 positions available. The user may employ these additional channel monitor positions by wiring directly to the switch terminals, and removing the rotary stops from the switch.

PARTS LIST

MAIN CHASSIS

Reference Designator	Ordering Number	Name and Description
A1	27-01-042913-04	PCB assy., amplifier
F1,2	51-04-100463-01	Fuse, 0.5A, 250V
J1	21-02-123285-01	Receptacle, audio, 3-soc
LS1	50-03-025155	Speaker, full range
P1	21-01-118626-01	Connector
R1,2	47-03-119305-01	Res., 100k Ω \pm 1%, 1/4W
S1	51-01-045838-01	Switch, rotary, 12-pos.
T1	56-08-007382-07	Transformer, power
TB1,2	21-04-108988-01	Terminal board, 10-term.
TB3	21-04-100399-01	Terminal strip, 2-term.
TB4	21-04-101013-01	Terminal board, 5-term.

AMPLIFIER PCB ASSEMBLY (27-01-042913-01)

Reference Designator	Ordering Number	Name and Description
C1,3	15-01-100278-02	Cap., 470 μ F, 50V
C2	15-01-107452-01	Cap., 10 μ F, 50V
C4	15-02-100109-01	Cap., 100 nF \pm 2%, 100V
CR1,2,3	48-02-042787-01	Rect., 1N4004, 1A, 400 PIV
IC1	17-01-119185-04	Int. Ckt., LM384
IC2	17-01-118679-01	Int. Ckt., +18V Reg.
R1	47-06-108701-01	Pot., 25 k Ω \pm 30%
R2	47-01-102016-01	Res., 2.7 Ω \pm 5%, 1/4W
T1	56-04-004834-01	Transformer, Input

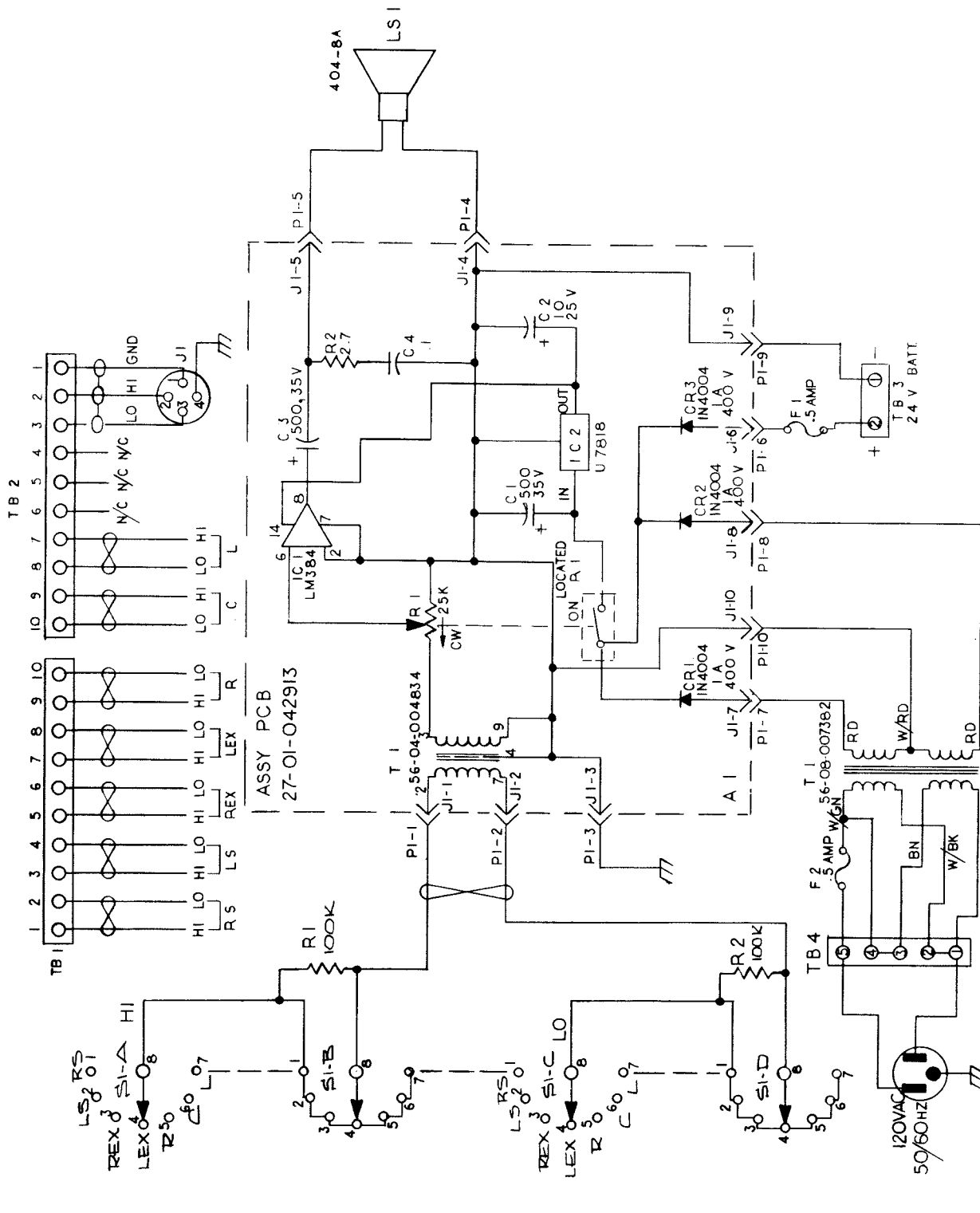

- 6. CAPACITOR VALUES ARE IN MICROFARADS.
 - 5. RESISTOR VALUES ARE IN OHMS $\frac{1}{4}$ W, 5 %.
 - 4. FOR TEST SPEC SEE IOA787
 - 3. FOR WIRE LIST SEE IO B 807
 - 2. FOR SEPARATE ASSY. DWG SEE IO D 399.
 - 1. FOR SEPARATE BILL OF MATERIAL SEE I 6 98.
- NOTES: UNLESS OTHERWISE SPECIFIED

Figure 1. Schematic (10C783-01), 1698 Amplified Monitor Panel