

# Film-Tech

The information contained in this Adobe Acrobat pdf file is provided at your own risk and good judgment.

These manuals are designed to facilitate the exchange of information related to cinema projection and film handling, with no warranties nor obligations from the authors, for qualified field service engineers.

If you are not a qualified technician, please make no adjustments to anything you may read about in these Adobe manual downloads

[www.film-tech.com](http://www.film-tech.com)

# INSTRUCTION MANUAL

## DPC

Xenon Projection Console

Type 25506

Rev. October 2001



**STRONG  
INTERNATIONAL**

a division of Ballantyne of Omaha, Inc.  
4350 McKinley Street  
Omaha, Nebraska 68112 USA  
Tel 402/453-4444 • Fax 402/453-7238



## PREFACE

THE STRONG **DPC** Xenon Projection Console is designed and manufactured by Strong International for use with Digital Light Projectors (DLP). The console lamphouse incorporates an interference-coated deep ellipse nickel reflector mounted in a fixed position, and utilizes a horizontal xenon bulb as the light source. The standard reflector is 15.325 inches in diameter and mounts 30 inches from the image plane of the projector.

A SIMPLIFIED CONTROL CIRCUIT ignites the xenon bulb using a DC Pulse Igniter Assembly. The igniter operates when provided high DC open circuit voltage normally developed by the xenon power supply at start-up, and requires no AC inputs. Operating current is displayed on the ammeter, and pressing the LAMP VOLTS switch will indicate the DC voltage at the arc. An optional digital readout screen provides a continuous display of current, voltage, wattage, and elapsed hours.

SERVICE AND MAINTENANCE are accommodated by hinged access doors. Key locks assure access to authorized personnel only. Interlock switches at the rear and both lamphouse access doors disable operation of the xenon bulb if these doors are opened during lamphouse operation.

AIR FLOW INTERLOCK SWITCHES, installed at the lamphouse upper blower inlet and at the base of the exhaust duct, will prevent bulb ignition if the blowers are not operating. The switches will also interrupt operation of the bulb if air flow falls below an adequate cooling level.

ADJUSTMENT CONTROLS to position the xenon bulb in relation to the reflector are located on the back of the bulb enclosure. A small access door is incorporated in the rear access door to permit manipulation of the bulb adjustment controls while the lamp is operating. The body of the control mechanism allows horizontal and vertical movement of the bulb, and rotation of the threaded center section adjusts bulb focus. Lock screws secure the mechanism when the bulb is correctly positioned.

A MANUALLY OPERATED DOUSER permits shutting off the light to the projector. The douser is normally left in the OPEN position when the lamp is used in conjunction with an automation system. To prevent deterioration of the douser plate, do not operate the lamphouse for a prolonged period with the douser closed. Do not, under any circumstances, operate the lamphouse in excess of (25) minutes with the douser closed. Observe the HIGH TEMPERATURE warning on the lamphouse snood adjacent to the douser handle. Surface temperatures may reach hazardous levels when the bulb is operating.

# DIGITAL PROJECTION CONSOLE ("DPC")

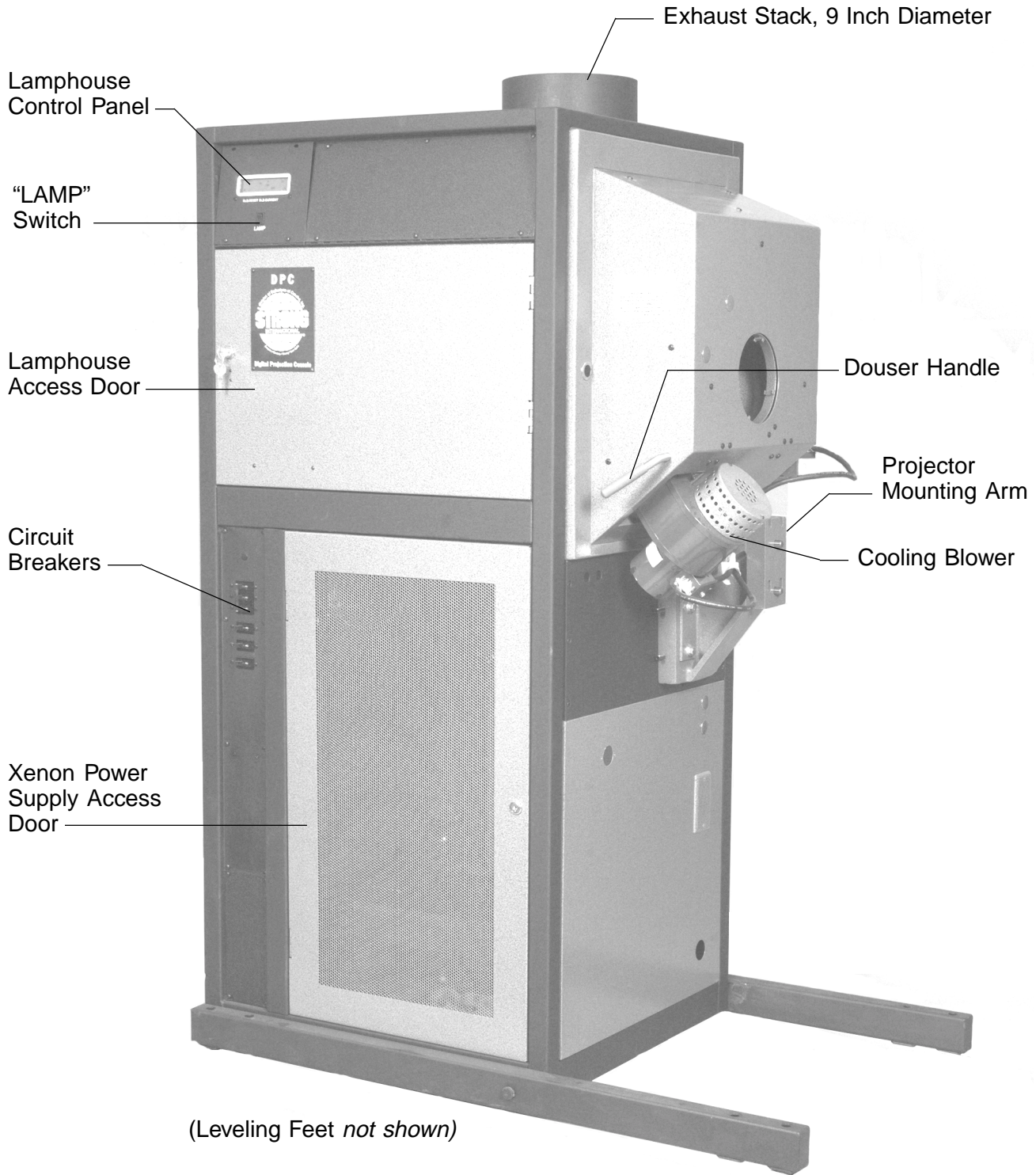

## RECEIVING & INSTALLATION

INSPECT THE SHIPMENT immediately and report any damage to the freight carrier. It is the responsibility of the consignee, not the shipper, to press damage claims. Strong International will provide shipping documents upon request.

MOVE THE CONSOLE on its base pallet as far as possible to its intended location. After removing the console from the pallet, install the four leveling pads and level the console to the booth floor. NOTE: If the booth floor is a soft material, such as linoleum, it is advisable to obtain four steel plates measuring approximately 4 inch x 4 inch x 1/4 inch (100 x 100 x 6.3mm) to place under the leveling pads to prevent "settling."

THE LEVELING FEET on the console are adjustable by loosening the locknut and raising or lowering the corner by turning the stud of the leveling foot with an end wrench. Retighten the locknut after leveling the console.

THE OFF-OPERATOR SIDE DOOR is equipped with a six-inch (15.2cm) blower for cooling the xenon power supply. Check the molded plug electrical connections for good contact; vibration from shipping and handling may loosen this connection.

CORRECT INSTALLATION of the desired xenon bulb in the DPC is determined by the size of the cathode support collet installed in the lamphouse. The collet installed is determined by the bulb model and type specified on the original equipment order. Open the lamphouse access door, remove the stainless steel bulb compartment cover, and examine the cathode support collet. Notify your Strong International Dealer if the collet is not appropriate to your desired xenon bulb.

<u>Bulb</u> <u>Wattage</u>	<u>Collet</u> <u>Part No.</u>	<u>Overall</u> <u>Length</u>	<u>Socket</u> <u>Diameter</u>
2000 & below	72-00064	4-1/2" (10.4cm )	.475" (12mm)
2000, 3000 "HS"	72-00142	4-11/16" (11.9cm)	.312" (8mm)
2500 "HS"	72-00142	4-11/16" (11.9cm)	.312" (8mm)
3000	72-00065	3-5/8" (9.2cm )	.551" (14mm)
4000-4500 "HS"	72-00066	3-1/2" (8.9cm )	.312" (8mm)
5000*	72-00067	3-7/8" (9.8cm)	.710" (18mm)
5000-7000 "HS"	72-00066	3-1/2" (8.9cm )	.312" (8mm)
3000-7000 "H/VC"	72-00065	3-5/8" (9.2cm )	.551" (14mm)

\* Osram XBO5000W/H OFR; other types, consult Factory

## EXHAUST SYSTEM INSTALLATION

THE EXHAUST STACK of the console lamphouse is designed to fit an nine inch (228mm) diameter duct. This size ducting must be used throughout the entire system and installed to eliminate any possibility of downdraft or rain dripping into the lamphouse. The exhaust blower must be capable of removing 300 cubic feet (8.5 cubic meters) of air per minute for bulb wattages ranging from 1000 to 3000 watts, and 500 cfm (14 cubic meters) for 4000 watts and higher. Install bypasses rather than dampers if it is necessary to restrict the air flow.

IF MORE THAN ONE CONSOLE is installed in a common projection booth, the above exhaust air flow must be measured at *each* individual console's exhaust stack. Inadequate exhaust draft can contribute to premature xenon bulb failure.

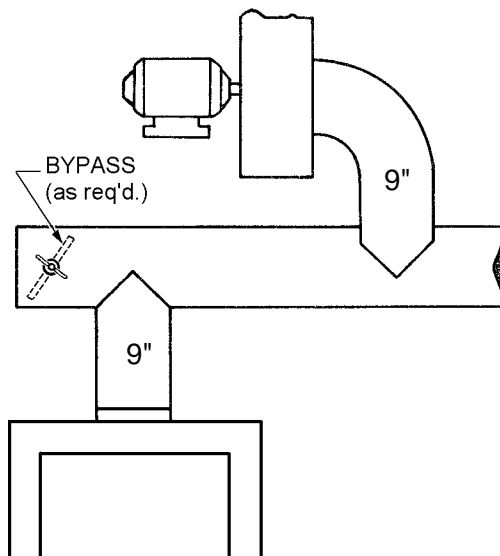

## WIRING INSTALLATION

ALL INSTALLER CONNECTIONS to the DPC are made to the five-terminal barrier strip (TB1) and its adjacent ground lug located behind the rear access door between the lamphouse burner plate and the xenon power supply.

BECAUSE OF HIGH VOLTAGES impressed during the ignition cycle, the console *must* be grounded. Connect an adequate earth ground to the grounding lug adjacent to the terminal board.

THE AC REQUIREMENT for the DPC is a four-wire three phase line (three phase plus neutral), with a separate earth ground. Voltage requirements are stamped onto the Name and Data Plate. All branch circuits are derived from this main input. The AC supply must be installed by a qualified electrician in conformance to local codes. Hardware, wire sizes and conduit types must comply with local codes. A readily accessible disconnect device shall be incorporated in the AC supply line to permit the operator to turn off all power to the console if required. Installer connections include three **phase** "hot" connections to Terminals **1**, **2**, and **3**, and a **neutral** connection to Terminal **5**. A jumper wire from Terminal 5 to Terminal 4 may be added if additional neutral feeds are required.

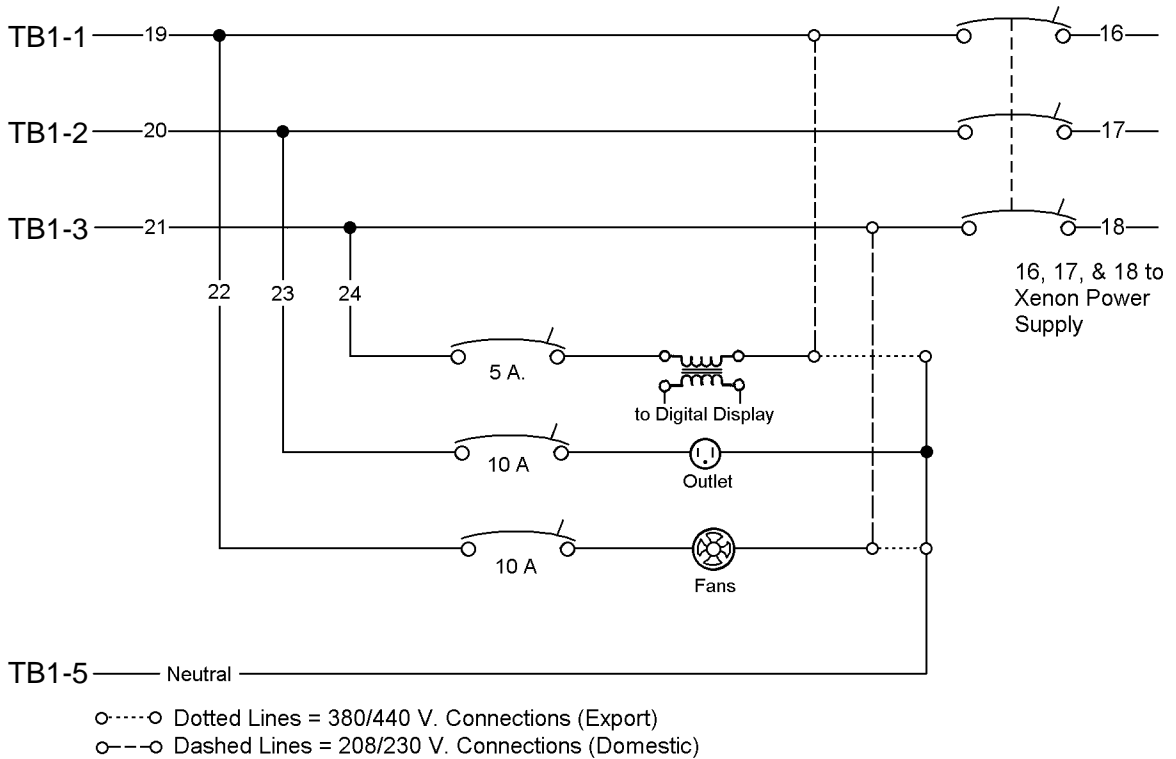
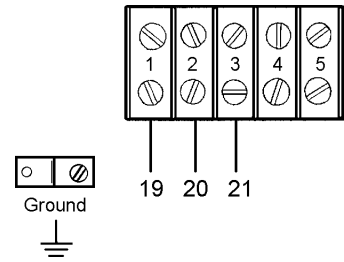



## SAFETY PROCEDURES

THE XENON BULB is highly pressurized. When ignited, the normal operating temperature of the bulb increases the pressure to a level at which the bulb may explode if not handled in strict accordance to the manufacturer's operating instructions. The bulb is stable at room temperature, but may still explode if dropped or otherwise mishandled.

REFER bulb replacement and service to **QUALIFIED PERSONNEL** with adequate protective clothing (face shield, clean cotton gloves, welder's jacket). For routine lamphouse service, observe the following rules:

1. Allow the bulb to cool to room temperature before opening the lamphouse. Put on protective clothing described above.
2. De-energize the xenon power supply at the AC source before opening the lamphouse compartment.
3. When possible, encase the bulb in its protective cover when cleaning or servicing the lamphouse interior. The bulb, when outside the lamphouse, must be encased in the cover.
4. Clean the bulb after it has cooled to room temperature. Do not touch the quartz envelope of the bulb; fingerprints will burn in and create hot spots which may shorten bulb life. If fingermarks are made, they should be carefully removed with methyl alcohol and cotton prior to bulb operation.
5. Never view an ignited bulb directly. **BLINDNESS OR PERMANENT EYE DAMAGE MAY BE INCURRED.**
6. Use only xenon bulbs designated as **OZONE FREE**. When possible, vent the lamphouse exhaust to outside atmosphere.
7. Maintain the lamphouse blower in good operating condition. Keep the blower inlet clean for unrestricted air flow.
8. To insure maximum bulb life, operate the lamphouse blower and the exhaust system for at least ten minutes after extinguishing the bulb.
9. If returning a bulb for warranty adjustment, pack it in its original shipping container. Complete and return all required warranty information.
10. Dispose of expired bulbs that are beyond warranty in the following manner: Wrap the bulb tightly in several layers of canvas or heavy cloth. Place it on a hard surface and shatter the envelope with a sharp hammer blow. **DO NOT** place an unshattered bulb in an ordinary refuse container.
11. **DO NOT PERMIT UNAUTHORIZED PERSONNEL TO PERFORM OR ATTEMPT ANY PHASE OF XENON BULB HANDLING OR SERVICE.**

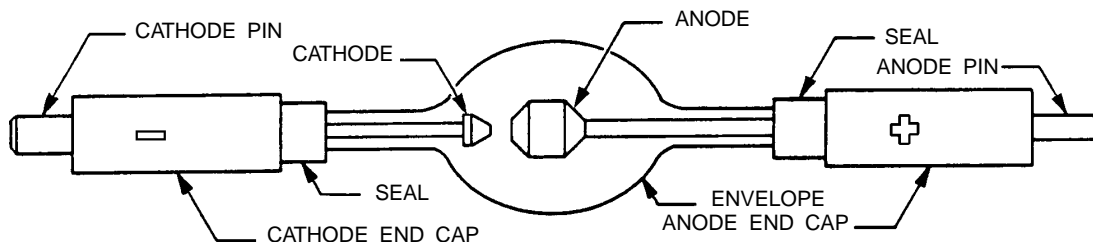

## DPC XENON BULBS

THE FOLLOWING XENON BULBS are approved for use in the Strong DPC. Bulbs not listed below must be certified by their manufacturer as being 100% interchangeable, and be classified as ozone-free. Dimensions of 5000 watt bulbs vary by manufacturer; *consult factory*.

<u>WATTAGE</u>	<u>OSRAM® Part No.</u>	<u>Hanovia® Part No.</u>	<u>ORC® Part No.</u>	<u>Lighting Technologies Int'l.</u>
1000	XBO1000W/HS OFR	XH1000HS	XM1000HS	LTIX-1000W-HSC
1600	XBO1600W/HS OFR	XH1600HS	XM1600HS	LTIX-1600W-HSC
2000	XBO2000W/H OFR	XH2000HW	XM2000H/VC	LTIX-2000W-HC
2000 (short) <sup>1</sup>	XBO2000W/HS OFR	XH2000HS	XM2000HS	LTIX-2000W-HS
2500 <sup>1</sup>	XBO2500W/HS OFR	XH2500HS	XM2500HS	LTIX-2500W-HSC
3000	XBO3000W/H OFR	XH3000HW	XM3000H/VC	LTIX-3000W-H
4000-4500	XBO4000W/HS OFR	XH4200HS	XM4500HS <sup>2</sup>	LTIX-4500W-HS
7000	XBO7000W/HS OFR	XH7000HS	XM7000HS <sup>2</sup>	LTIX-7000W-HS

<sup>1</sup> Requires Anode Adapter 40293 but no Cathode Adapter

<sup>2</sup> also available in H/VC configuration using 24180 Support Collet

A CATHODE ADAPTER is required for 1000 and 1600 watt bulbs only, and is supplied in the accessory kit only when these wattages are specified on the original equipment order. The stem of the cathode adapter is designed for use with the standard 2000 watt bulb support collet 24179 (12mm I.D. socket). Anode adapters, where used, mount to the bulb's anode pin with a 1/4-20 set screw (supplied).

THE CATHODE ADAPTER is drilled and tapped 5/16-18 to accommodate the threaded cathode pin used on the 1000 and 1600 watt bulbs. When screwed onto the cathode pin, the adapter positions the arc at the correct focal point. The chromed anode adapter mounts to the pin of the anode end cap, and rests in the bulb yoke in front of the reflector to support the front of the bulb. A lead assembly (71969) is attached to the 31243 anode adapter to supply positive DC current to 1000 and 1600 watt bulbs.

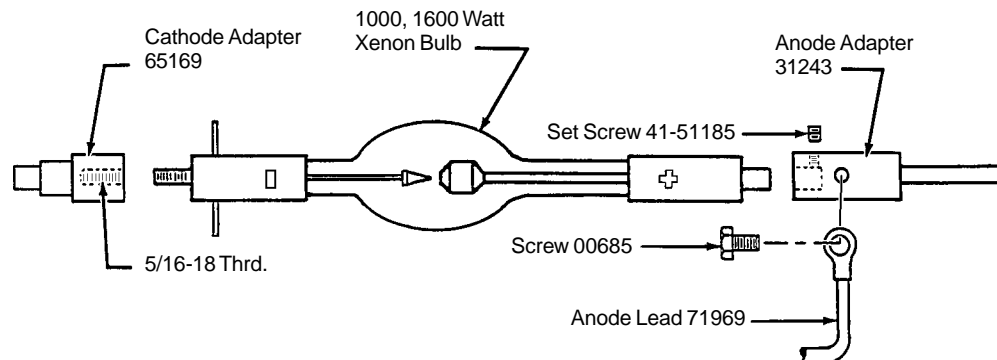

ASSEMBLE THE ADAPTERS to the bulb prior to removing the plastic protective covering. DO NOT apply mechanical stress to the quartz envelope. Firmly tighten all fasteners before installing bulb and adapters.

## XENON BULB INSTALLATION & OPERATION



Only qualified and trained professional technical personnel are allowed to operate the equipment. Refer service and maintenance to trained personnel. Untrained personnel are not allowed in the projection booth during operation, service, or maintenance.



**OBSERVE ALL SAFETY PROCEDURES** when working around the xenon bulb. Leave the bulb in its protective plastic cover whenever possible, and remove immediately any fingerprints accidentally placed on the quartz envelope.

**OPEN THE LAMPHOUSE COMPARTMENT ACCESS DOOR** and dismount the cover plate from the xenon bulb enclosure. Set the cover plate and thumb screws aside. Slide the contact clamp on the igniter lead over the slotted brass socket portion of the rear support collet.

**CONNECT THE ANODE LEAD** to the positive (+) end cap of the xenon bulb if the lead is not factory attached. Tighten the connection firmly to insure a secure electrical contact and to prevent overheating. Anode leads normally use uninsulated wire; a length of silastic rubber tubing is supplied as an insulator.

**HANDLE THE BULB** by the metal end caps only. Insert the bulb into the reflector, passing the cathode (-) end cap through the center hole in the back of the reflector. Seat the cathode pin, or the stem of the cathode adapter, into the socket of the rear bulb collet as far as possible to permit full focus travel. Rest the anode (+) end cap or anode adapter in the bulb support yoke in front of the reflector.

**SECURELY TIGHTEN** the socket head clamping screw in the igniter lead contact clamp. Make certain the cathode (-) pin is firmly secured to the socket of the bulb collet. Attach the terminal of the anode (+) lead to the stud of the binding post located adjacent to the front bulb support. Dress the anode lead in front of the support yoke to minimize shadows. Insulate the bulb lead using the silastic rubber tube as required. Tighten the fastening hardware securely to insure good electrical conduction.

**REMOVE THE PLASTIC COVER** from the xenon bulb. Replace the cover plate over the bulb enclosure and secure with the thumb screws. Close and lock the lamphouse compartment access door. Turn on the lamphouse exhaust system.

**ENERGIZE THE CONSOLE AC INPUTS** at the main breaker panel. Place the switching circuit breakers in the ON position. The POWER light on the analog control panel will glow, and the AIR and DOOR lights will glow when their interlock switches close. The backlighting of the optional LCD screen on the digital control panel will glow. The cooling fans will start. Operation of the cooling and exhaust blowers will actuate the air flow switches.

**THE DIGITAL CONTROL PANEL** includes no indicator lights. The POWER ON state is indicated by the display being backlit and showing zero current and voltage. Failure to turn on exhaust air or to secure access doors is displayed as "CHECK EXHAUST" or "CHECK DOOR." A flashing asterisk (\*)

## **BULB INSTALLATION & OPERATION (continued)**

indicates that the display is active and awaiting inputs. NOTE: the interlock detection circuit features a five minute “bobble” delay to allow the exhaust blower to reach full speed and eliminate air flow backdrafts.

IGNITE THE XENON BULB by pressing the LAMP rocker switch on the lamphouse control panel. When this switch is closed, the lamphouse control circuit will energize the coil of the xenon power supply contactor. When the initial high DC “no load” surge from the power supply reaches 130 volts, the DC Pulse Igniter will energize. The igniter will supply a high voltage pulse across the electrodes of the xenon bulb.

THE HIGH VOLTAGE IGNITER PULSE, coupled with the high DC open circuit (“no load”) voltage from the xenon power supply, will ignite the xenon bulb. A “cold” bulb will generally ignite after one pulse; a bulb still warm from prior operation may require two or three pulses. A short delay between ignition pulses, as power supply capacitors re-charge, is normal.

UPON IGNITION, the DC voltage will fall to the low sustaining level required for continuous operation. The DC Pulse Igniter ceases operation below 130 V.DC. Allow a minute for the current to stabilize, and check the operating current on the ammeter.

THE OPTIONAL DIGITAL DISPLAY will continuously read out DC current, arc voltage, operating wattage, and elapsed time. No switching is required to change display modes. The flashing asterisk symbol (\*) will turn into a plus (+) sign until the bulb is extinguished.

ADJUST THE XENON POWER SUPPLY as required to provide the correct DC output to the bulb. Directions for adjusting the DC output of the xenon power supply are included in the separate Instruction Manual furnished with the power supply. Do not exceed the maximum current specified for the rated wattage of the bulb. See the warranty information packaged with the bulb and comply with the manufacturer’s recommendations. The following figures may serve as a guideline to complete this phase of the installation; in the event of conflict, the bulb manufacturer’s figures shall prevail.

<b><u>Bulb Wattage</u></b>	<b><u>Nominal Current</u></b>	<b><u>DO NOT EXCEED</u></b>
1000	50 A.	58 A.
1600	65 A.	70 A.
2000	75 A.	90 A.
2500	90 A.	100 A.
3000	95 A.	100 A.
4200	135 A.	150 A.
5000	145 A.	155 A.
7000	150 A.	160 A.

## BULB INSTALLATION & OPERATION (continued)

A NEW BULB is normally operated at or slightly below the “nominal” current level. As the bulb ages, the quartz envelope will darken and the light output will decrease. To restore the light output, the operating current can be gradually increased to, but not exceeding, the maximum current. Because of manufacturing tolerances on xenon bulbs, one lamp in a two-machine booth may operate at a slightly higher or lower current setting than the other to balance the light on the screen.

ONCE OPERATING at its correct current setting, position the console to center the light on the screen. The optical system of every DPC is laser-aligned at the factory in the course of assembly and testing. This alignment procedure positions the reflector to best collect the light generated by the xenon arc and project it to the image plane. The *focal distance* is the space between the arc and the reflector, and is determined by the use of the correct bulb support collet. The *working distance* is the space between the digital image plane and center hole of the reflector, and is set by the dimensions of the projector mounting arm casting.

A SUPPORT BRACKET, designed to position the light input to the digital projector directly on the optical center of the console lamphouse, is factory installed on the console’s mounting arm. Do not alter the position of this bracket prior to mounting the digital projector. Two alignment pins, (1) keyed and (1) round, conform to holes in the base of the digital projector.

BEFORE MOUNTING THE PROJECTOR, open the lamphouse douser and project a white light to the screen. *Exercise extreme caution during this procedure*; intense heat is present in the light beam, and skin and clothing can burn rapidly if held in the light beam. It is furthermore *mandatory* to wear the UV protective goggles supplied in the console accessory kit when performing this operation. Do not look into the lamphouse, and advise bystanders to look away from the console.

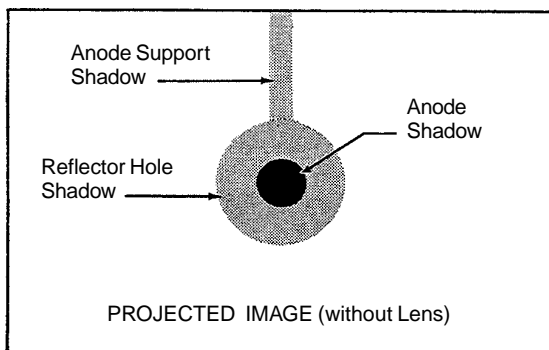
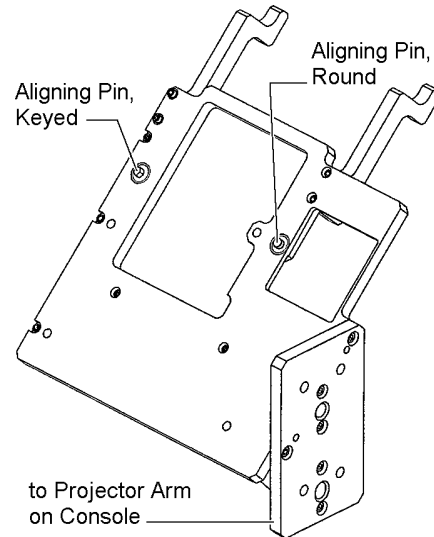

THE IMAGE projected to the screen, without the projection lens, is that of the center hole of the reflector, and the shadow of the anode (the larger of the two electrodes in the xenon bulb). The projection of the anode shadow will appear on the screen as a darker spot surrounded by the grey area of the reflector center hole. The darker areas will not necessarily be centered on the screen, or appear as concentric as those illustrated. The location of the bulb, and the position of the console itself, must be shifted to achieve an image such as that illustrated. Locate first the Bulb Adjustment Controls.

## BULB INSTALLATION & OPERATION (continued)

THE BULB POSITIONING MECHANISM is mounted to the back of the bulb enclosure inside the lamphouse compartment, and is accessible through the small hinged door in the rear console access door.

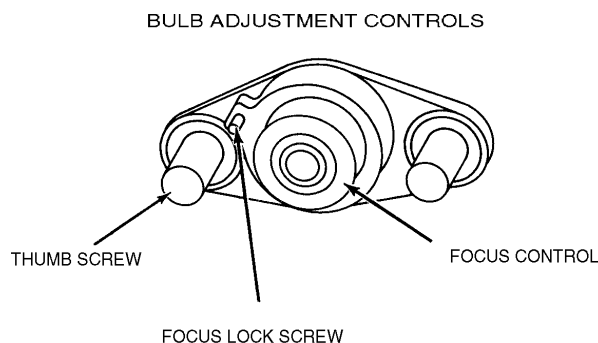

THE CENTER SECTION of the control is a threaded member that focuses the bulb in relation to the reflector. Turning this adjustment moves the bulb in only one plane, into or away from the reflector. Clockwise rotation moves the bulb away from the reflector. The small knurled screw to the left of this section can be tightened to lock the focusing mechanism, after the following procedures have been completed.

THE THUMB SCREWS on either side of the focusing control lock the horizontal and vertical adjustment mechanism in position. The thumb screws are spring-loaded to apply a degree of tension between the mechanism housing and the back of the bulb enclosure.

TURN THE CENTER FOCUSING SECTION of the bulb positioning control until the smallest black spot obtainable is focused on the projection screen. It may be best to run this adjustment both directions to permit positive identification of the spot. The position of the spot may be to the right, left, top or bottom of the screen, and not necessarily at the center.

LOOSEN the two thumb screws, one on either side of the focusing section just enough to permit manual movement of the complete assembly. The bulb adjustment control will now move about these two spring-loaded thumb screws, and as this control is shifted, the smooth shadow of the electrode can be seen extending beyond the projected hole in the reflector. Move the control section around the two thumb screws until the black spot is as round as possible to project. It may be necessary to again adjust the focus control to define a sharp spot. The electrode shadow must be centered in the projected hole of the reflector.

AT THIS TIME, the console base should be moved to center the dark spot horizontally on the screen, and the console tilted to center the dark spot vertically on the screen. Loosen the (2) tilt locking screws before operating the scissors jack to set the projection angle. The tilt locking screw on the operator's side is accessible by removing the cover plate below the breaker panel (see Figure 1, Item 19), and on the off-operator's side by opening the off-operator side access door.

## BULB INSTALLATION & OPERATION (continued)

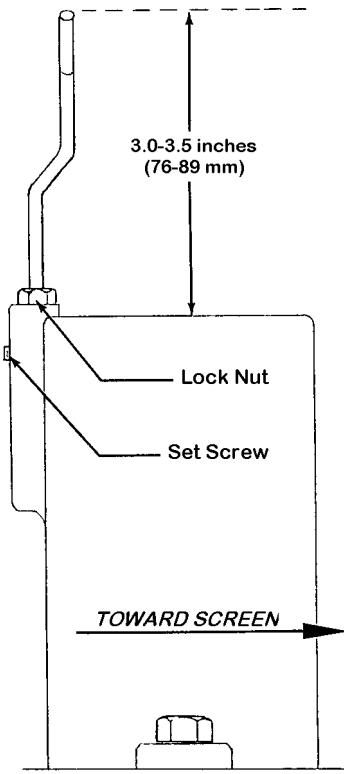

IF THE BULB ADJUSTMENT CONTROL is at its extreme limit of travel (left-to-right or top-to-bottom), shut off the lamp, allow the bulb to cool, and open the lamphouse door. Remove the stainless steel bulb enclosure cover and loosen the set screw securing the front bulb yoke. Reposition the yoke left-to-right or up-and-down to compensate.

THE FRONT BULB SUPPORT YOKE is adjustable and is factory-set to accommodate the end cap diameter of the xenon bulb specified on the sales order. A height of 3-1/8 to 3-1/4 inch is normal for most commonly used bulbs, but bulbs with larger diameter end caps (i.e. ORC 4500 and 7000 watt models) may require setting the yoke as low as three inches. To adjust the yoke position, loosen the set screw in front of the yoke, and raise or lower the yoke as required. A hex nut is provided to lock the height once selected. Re-tighten the set screw when finished.

AFTER THE BLACK SPOT is as even around the outside as possible to project, and centered in the shaded area as shown on the preceding page, tighten the two thumb screws to lock the adjustment section. This adjustment has now centered the projected image of the electrode shadow and the hole in the reflector on the aperture and screen. If the spot raises or lowers as the focus screw is turned, it is necessary to re-adjust the front bulb yoke as instructed above.

TO ALLOW FOR MANUFACTURING TOLERANCES in overall bulb length and/or fabrication of the stainless steel bulb enclosure, an additional degree of fine adjustment is available by changing the position of the snap ring(s) retaining the bulb support collet in its bearing. Use this feature only if the proper focal position cannot be gained by use of the focus screw.

TO REPOSITION THE COLLET, extinguish the bulb and allow the lamp to cool. Observing all safety precautions, remove the xenon bulb. From the rear of the bulb enclosure, remove the 21-48027 Snap Ring (see Detail drawing, Figure 2 Parts List) and withdraw the collet from the inside of the bulb enclosure. Position the inner snap ring as required, and re-install the collet by securing the outer snap ring.

CLOSE THE LAMPHOUSE DOUSER and extinguish the xenon bulb by placing the LAMP switch in the OFF position. Install the digital projector to the mounting bracket on the front of the console. Make certain the (2) registration pins are correctly aligned before securing the mounting hardware. Make all electrical connections as specified by the projector manufacturer. Energize the projector and select a "100% White" test pattern. Ignite the xenon bulb and open the lamphouse douser. Maximize the screen illumination according to the projector manufacturer's instructions.

## BULB INSTALLATION & OPERATION (continued)

THE IDEAL “FLAT” FIELD denotes a pattern of light without a distinct “hot” spot in the center of the screen, and only a slight reduction of light in the four corners. If the screen light cannot be properly maximized by projector adjustments, or if the position of the projector mounting bracket shifted in transport, there are additional measures to adjust lamphouse light output.

THE REFLECTOR BULK-HEAD CASTING is fixed to the lamphouse burner plate and requires no adjustment. The entire burner plate may be adjusted by loosening the (4) socket head tie-down screws and shifting the burner plate on its base plate. Alternately tightening and loosening the (6) headless adjusting screws will raise or lower the front or back of the burner plate, thereby redirecting the light beam.

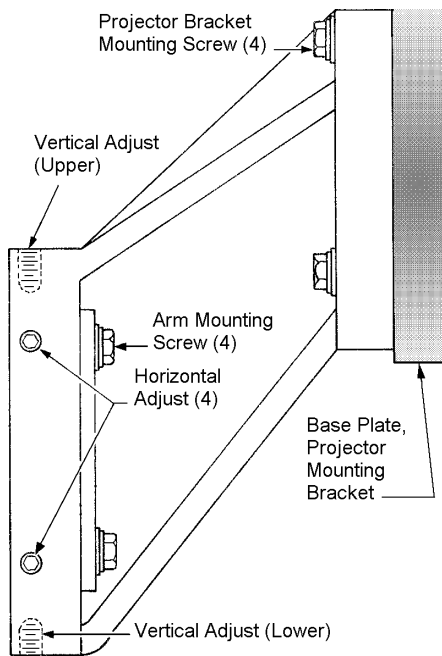
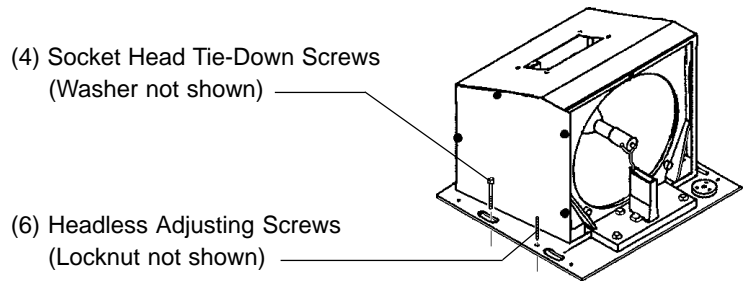

IF REPOSITIONING THE BURNER PLATE fails to achieve maximum light utilization, the projector mounting arm provides a second method of adjusting the alignment between the console and the digital projector. Loosening the (4) hex head arm mounting screws, and alternately tightening and/or loosening the (6) headless adjusting screws moves the position of the projector.

LOOSEN each of the (4) hex head arm mounting screws approximately one-half turn with a 9/16 inch end wrench. The mounting arm can then be relocated by alternately tightening or loosening the (6) adjusting screws using a 3/16 inch allen wrench. Adjusting the top and bottom screw moves the mounting arm up and down, and adjusting the four screws on the sides moves the arm in a horizontal plane.

WHEN re-checking projector alignment, the four hex head arm mounting screws must be retightened. Make certain the four arm mounting screws are secured upon completion of the alignment procedure.

USE EITHER, or both, fine alignment procedures to insure maximum screen illumination. It is not necessary to repeat these procedures unless either the lamphouse reflector or the digital projector is replaced.



## **BULB INSTALLATION & OPERATION (continued)**

TO EXTINGUISH the xenon bulb, turn the LAMP rocker switch on the lamphouse control panel to its OFF position. Power readings on the display will fall to zero. Leave the console power ON to permit the blowers to operate and cool the bulb. Allow the blowers to operate for at least ten minutes after turning off the xenon bulb. A forced-air cooling cycle is *required* by xenon bulb manufacturers in order to fully comply with bulb warranty requirements.

RECORD THE HOURS of xenon bulb operation on the inside back cover of this manual. Use the (HR) figure displayed on the digital unit, as this figure indicates total system hours. Instructions for re-setting the (BLB) display follow in the DIGITAL DISPLAY section.

WHILE XENON BULBS generally will continue to perform well beyond their stated warranty life, *no credit* will be allowed by the bulb manufacturer for damaged reflectors in the event of an explosion if the bulb is beyond its warranty period. This should be considered when determining the time of bulb replacement.

UPON REPLACING THE XENON BULB, it will be necessary to repeat only the bulb alignment procedures outlined above. Mechanical lamphouse adjustments detailed in the preceding section are required only when a reflector or projector is replaced.

### **BULB ROTATION:**

MOST XENON BULB MANUFACTURERS recommend and/or require rotation of horizontal bulbs at 50% warranty life. Refer to the warranty information packaged with the xenon bulb for specific requirements.

TO ROTATE THE BULB, loosen the socket screw in the cathode clamp and remove the anode lead terminal from the positive binding post. Rotate the bulb 180 degrees, re-attach the anode lead terminal, and tighten the cathode clamping screw.

IF THE BULB'S ANODE LEAD is too short to reach the binding post from the rotated position, an anode lead extension with fittings is available from Strong International Dealers. Order (1) each of Lead Extension 71928, Connector 81349, and Insulation Tubing 71289.

ADJUST THE XENON POWER SUPPLY to increase operating current to or just below the maximum level specified for the bulb. Project a white light to the screen to check for an even field and correct the bulb positioning as required. Operate the xenon bulb at this higher current level for one or two performances, and then return the power setting to its previous level. Temporary operation of the bulb at high current following bulb rotation will restore the cathode tip and enhance ignition at the new arc position.

## **BULB INSTALLATION & OPERATION (continued)**

### BULB WARRANTY RETURNS:

RETURN BULBS upon which a warranty claim is being made to the theatre equipment dealer through whom the bulb was purchased. Pack the bulb in its original shipping carton with the protective cover over the bulb. Complete and enclose all warranty forms supplied by the bulb manufacturer.

WARRANTY CREDIT will *not* be allowed if the bulb failure is related to mishandling, incorrect installation, faulty supporting equipment, or abuse.

REFLECTORS damaged by a bulb explosion should be forwarded to the *bulb* supplier for warranty adjustment. Include an invoice copy authenticating the cost of the replacement reflector.

## ARC STABILIZING MAGNET ADJUSTMENT

THE ARC STABILIZING MAGNET is located on the lamp base below the reflector. This magnet is preset at the factory and should not require adjustment. If it should become necessary to adjust the magnet, the following procedure must be followed. Observe all safety procedures when working in the lamphouse compartment.

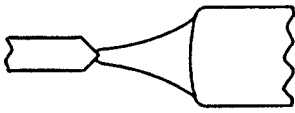

FIGURE A

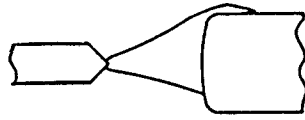

FIGURE B

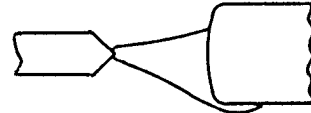

FIGURE C

THE NORMAL ARC, when viewed through the arc viewing port, will appear as in Figure A. This represents the correct magnet position.

FIGURE B shows the position of the arc when the magnet is too low. Raise the magnet on its adjustment bracket to lower the arc to the position illustrated in Figure A. FIGURE C shows the position of the arc when the magnet is too high. Lower the magnet to raise the arc to the position illustrated in Figure A.

THE MAGNET must always be installed with the longest portion of the magnet nearest the bulb, and with the SOUTH (S) pole pointing to the operator side access door. Reversing the magnet will cause bulb flicker, and may inhibit bulb ignition.

IN NEW EQUIPMENT, the magnet is normally in the center of the adjustment range. Changes in the magnet position are required only to correct an improperly burning arc (Figure B or C). Any replacement magnet should first be installed in the center position of the adjustment range. Raise or lower the magnet as required to center the arc as illustrated in Figure A.

## MAINTENANCE



WARNING: OPEN AC DISCONNECT BEFORE SERVICING UNIT.



THE STRONG DPC requires very little maintenance to keep it in good working order. Routine cleaning of the equipment is the most important element, and cleaning intervals are determined by the dirt and dust conditions at the installation site.

THE REFLECTOR should be cleaned with a soft, clean, dry cotton cloth every two weeks. If excessively soiled, a commercial liquid glass cleaner may be used. *Use no abrasives.* Exercise extreme care not to scratch or fingermark the coated surface.

CHECK ALL ELECTRICAL CONNECTIONS periodically for tightness. Particular attention should be paid to the DC connections at the bulb, the shunt, and the positive binding post.

THE BULB should be checked regularly for presence of dirt or foreign material on the envelope. Dirt or foreign material must be removed from the bulb immediately, or they will burn into the quartz envelope and shorten bulb life. NOTE: Observe all safety procedures when working around the bulb.

THE INSIDE of the lamphouse compartment and the blower intakes should be cleaned periodically, depending on the dust conditions at each installation. Keep all air inlet and outlet grilles clean and free from obstructions.

BOTH THE FRONT AND TOP LAMPHOUSE BLOWERS require periodic lubrication. Oil holes in the blower motor end bells are marked, and use of a squeeze-type, plastic injection oiler is recommended. NOTE: blower motors are thermally protected, and failure to routinely service them could cause overheating and periodic shutdowns. Interruption of the air flow will open lamphouse interlock switches and extinguish the xenon bulb.

THE SIX-INCH MUFFIN BLOWER in the off-operator side door is required for cooling the xenon power supply. This blower, like the built-in blowers used in the switching power supply, utilize sealed bearings and requires no lubrication.

## DIGITAL DISPLAY

UPON ENERGIZING the LAMP circuit, the backlighting will illuminate the LCD screen. When all blowers are operating and all access doors are closed and correctly secured, the display will appear similar to the example shown:

**000V 000A 0000W**  
**1234BLB 12345HR \***

FOR PURPOSES OF ILLUSTRATION, the above display indicates a non-operating bulb with 1,234 hours of use installed into a console with 12,345 hours of operation. The asterisk (\*) at the end of the second line, when flashing, indicates that the display is active and awaiting input. Upon bulb ignition, the upper line will display the arc voltage (V), the DC current (A), and the operating wattage (W) of the bulb. The figures will shift for the first few moments of bulb operation, but will stabilize after the bulb reaches operating temperature and pressure. A plus symbol (+) will replace the flashing asterisk.

IN THE EVENT of an open interlock switch, the lower line will display the appropriate diagnostic measure, i.e. CHECK REAR DOOR or CHECK EXHAUST. Diagnostic messages are often abbreviated, and are defined as follows:

- |                          |   |
|--------------------------|---|
| <b>CHECK REAR DOOR:</b>  | Make certain the rear console access door is closed and locked.   |
| <b>CHECK FRONT DOOR:</b> | Make certain the operator's lamphouse access door (right side, viewed from rear) is closed and locked.  |
| <b>CHECK NONOP DOOR:</b> | Make certain the lamphouse access door on the off-operator (left) side is closed and locked.  |
| <b>CHECK EXHAUST:</b>    | Make certain the exhaust blower has been switched on and is operating without obstruction. A five minute "bobble" delay in this circuit permits the exhaust blower to reach full speed and eliminate air flow backdrafts. |
| <b>CHECK TOP BLOWER:</b> | Make certain the large squirrelcage blower at the top of the console is energized and operating, and that the ducting to the bulb compartment is secure.  |

WHEN THE INTERLOCK CIRCUIT is complete, closure of the LAMP switch, or the automation closure, will energize the contactor of the xenon power supply. The high open circuit ("no load") DC voltage will be displayed. When the open circuit voltage reaches 140 V.DC, the igniter will generate a RF pulse to bridge the gap between the bulb electrodes. This pulse, coupled with the high open circuit DC voltage, will ignite the bulb. The voltage reading will then fall to the bulb's sustaining level, and the DC amperes (A) and wattage (W) will be displayed continuously until the bulb is extinguished. The flashing asterisk symbol (\*) will become a plus (+) sign.

## DIGITAL DISPLAY (continued)

ELAPSED HOURS will begin counting upon bulb ignition. Bulb hours (BLB) are limited to four digits, and can be re-set when the xenon bulb is replaced. To re-set bulb hours, press and hold (for 3 seconds) the RESET button accessible through marked hole below the LCD screen. The 5/64" allen wrench used to tighten the front bulb yoke set screw is the correct diameter to clear the hole. NOTE: when recording start-up and removal hours on the Xenon Bulb Record, use the *total elapsed hours* (HR) figures. The (BLB) figure, re-set upon installation of the bulb, is a convenience feature ONLY. Basing records of the lamp system on the total hours (HR) figures permits an accurate and ongoing history of bulb usage.

IF THE XENON BULB fails to ignite, additional diagnostic messages will be displayed on the LCD screen:

**CHECK PWR SUPPLY:** If no DC current is sensed, or open circuit voltage does not exceed 125 V.DC, check the xenon power supply. Repair or replace as required.

**CHECK IGNITER:** If the DC open circuit voltage reaches and exceeds 140 V.DC and the igniter fails to pulse, replace the igniter.

PRESSING and rapidly releasing the RESET button will display the last recorded diagnostic message. The message will be erased after power is shut off. NOTE: Pressing *and holding* the RESET button will set the BLB display to zero.

DIAGNOSTIC MESSAGES serve as prompts and suggestions but do not replace traditional troubleshooting procedures. If an access door is closed and secured but transmits an error message, check the subject door interlock switch with an ohmmeter and replace if defective. Dirt or dust fouling an air vane switch will cause a "blower" or "exhaust" error message. A "power supply" or "igniter" error message might be caused by a loose or oxidized connection.

OBSERVE THE DC CURRENT READING ("Amperes") when determining the operating level of the xenon bulb. Bulb manufacturers specify a maximum *current* level which must not be exceeded regardless of the "Wattage" reading on the LCD display.

# DPC LAMPHOUSE

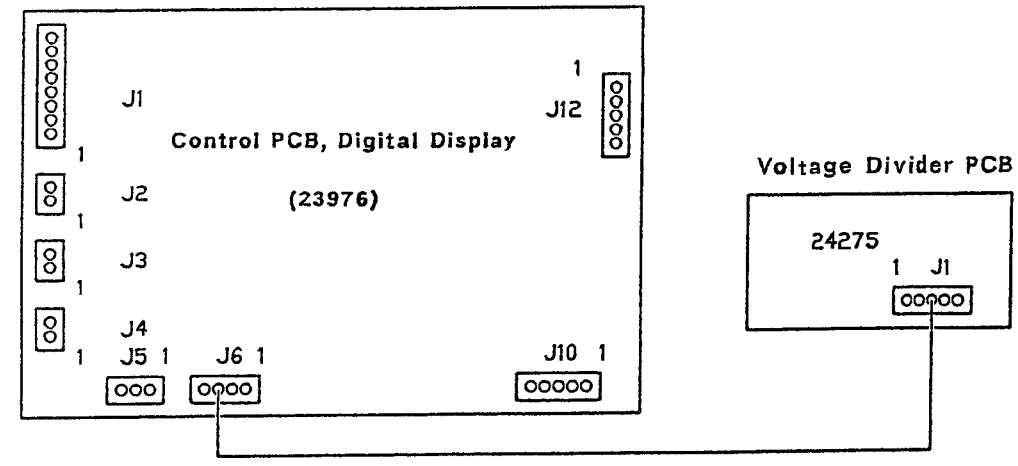
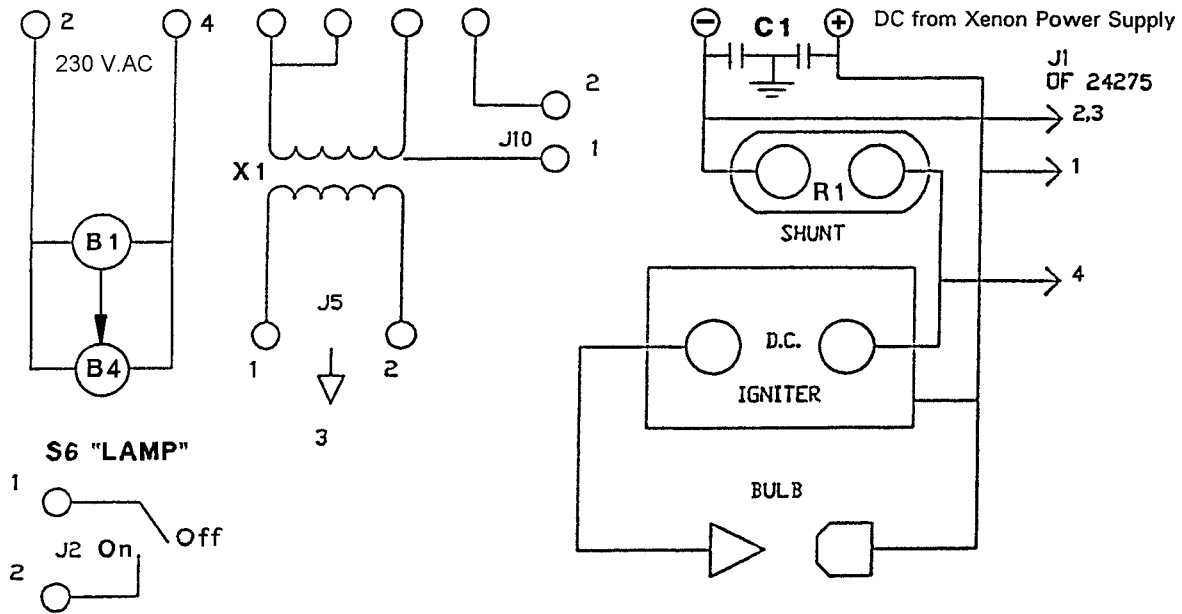

Xenon Bulb Ignition & Monitor Circuit

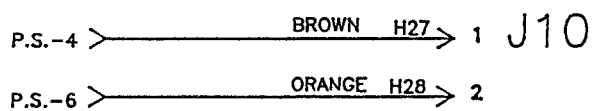
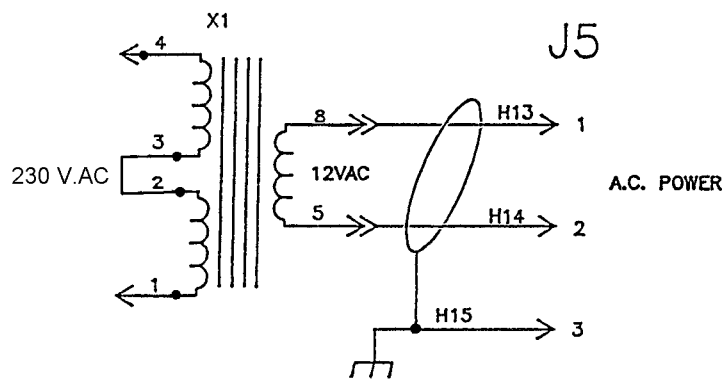
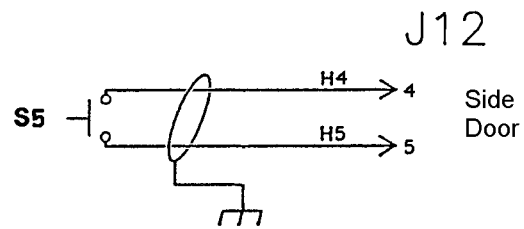
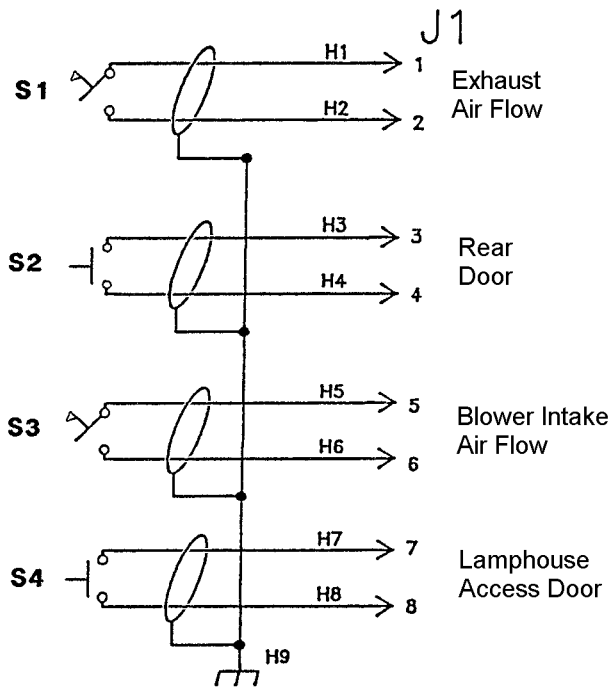

DPC Wire Harness



24275 Voltage Divider  
PCB Assembly  
(mounts to R1 Shunt)

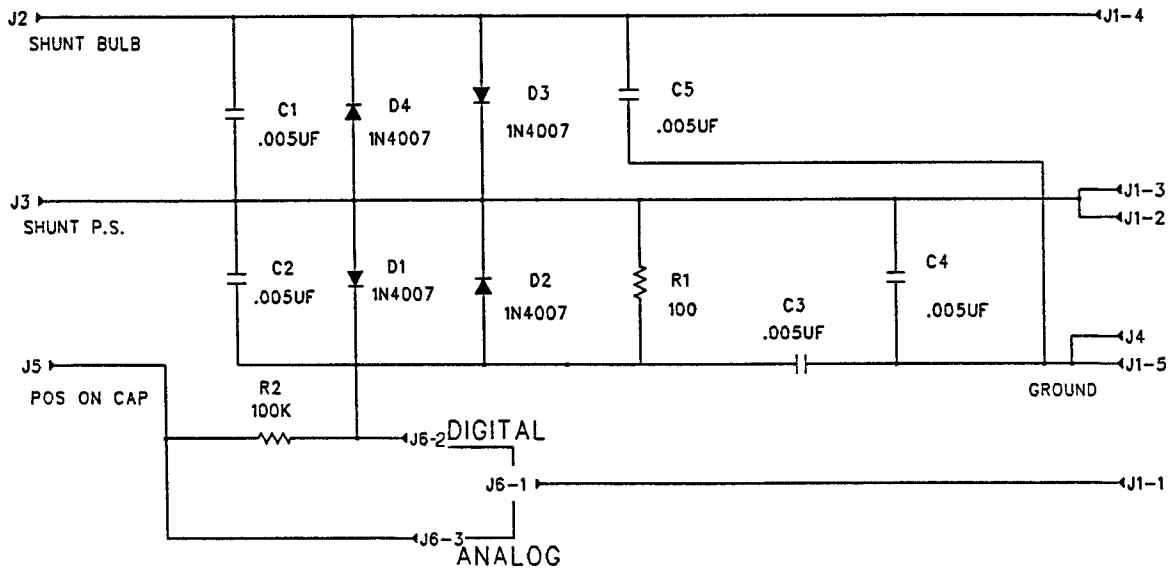
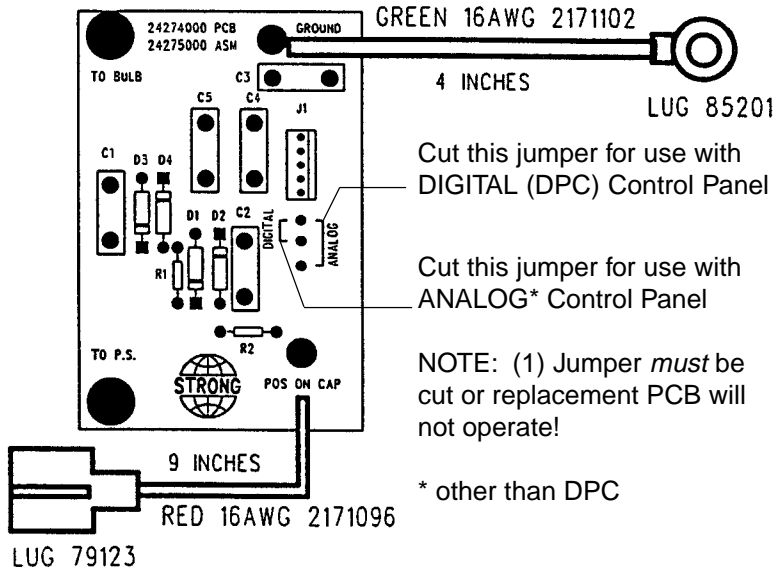

**PARTS LIST**  
DPC Lamp Control Wire Harness

Ref.		
<u>Desig.</u>	<u>Part No.</u>	<u>Description</u>
B1	11-33008	Squirrelcage Blower Assembly, 230 V.AC, 50/60 Hz.
B2,3	25598	Douser Blower Assembly, 230 V.AC, 50/60 Hz.
B4	71627	Blower, Side Door; 230 V.AC, 50/60 Hz.
IGN	39862	DC Pulse Igniter Assembly
-	39875	Igniter Case & Coil, Potted Assembly
-	25476	Igniter Printed Circuit Board Assembly
J1	21-37058	Connector, (8) Position
J3	21-37055	Connector, (2) Position
J5	21-37056	Connector, (3) Position
J10	21-37057	Connector, (5) Position
J12	21-37057	Connector, (5) Position
R1	82167	Shunt, 200 A. 50 mV.
S1	85109	Microswitch, Air Flow; Exhaust Stack
-	24419	Air Vane Paddle
S2	24406	Door Interlock Switch, Rear
S3	85109	Microswitch, Air Flow; Top Blower
-	24419	Air Vane Paddle
S4	24406	Door Interlock Switch, Lamphouse Access
S5	24406	Door Interlock Switch, Off-Operator Side
X1	11-64004	Transformer, 110/220 V.
-	56428A	Terminal, Spade Lug
-	41-62027	Terminal, Auto Clip (Push-On)
-	80195A	Terminal, Ring
-	81252	Butt Splice Connector (Small)
-	94262	Butt Splice Connector (Large)

**Voltage Divider PCB**  
Assembly No. 24275

Ref.		
<u>Desig.</u>	<u>Part No.</u>	<u>Description</u>
C1-C5	61-08025	Capacitor, .005 $\mu$ f, 3 kV.
D1-D4	51-17001	Diode, 1N4007
PCB	24274	Printed Circuit Board (less Components)
R1	61-46002	Resistor, 100 Ohm, 1/4 Watt 5%
R2	61-46043	Resistor, 100k Ohm, 1/4 Watt 5%
J1	21-37051	Connector, (5) Position

# 23976 DIGITAL DISPLAY CONTROL PC BOARD

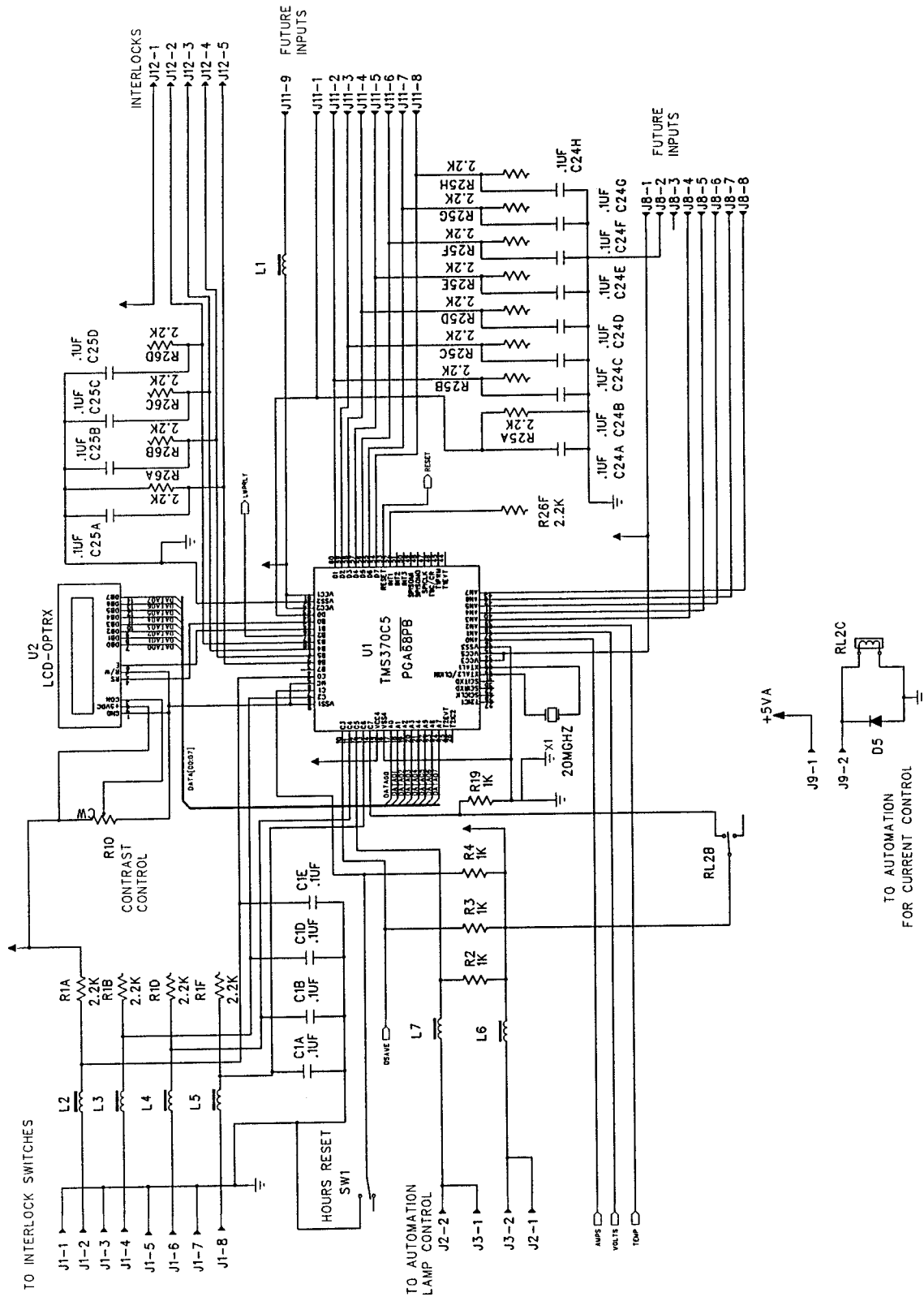

Wiring Diagram  
Page 1 of 3

# 23976 DIGITAL DISPLAY CONTROL PC BOARD

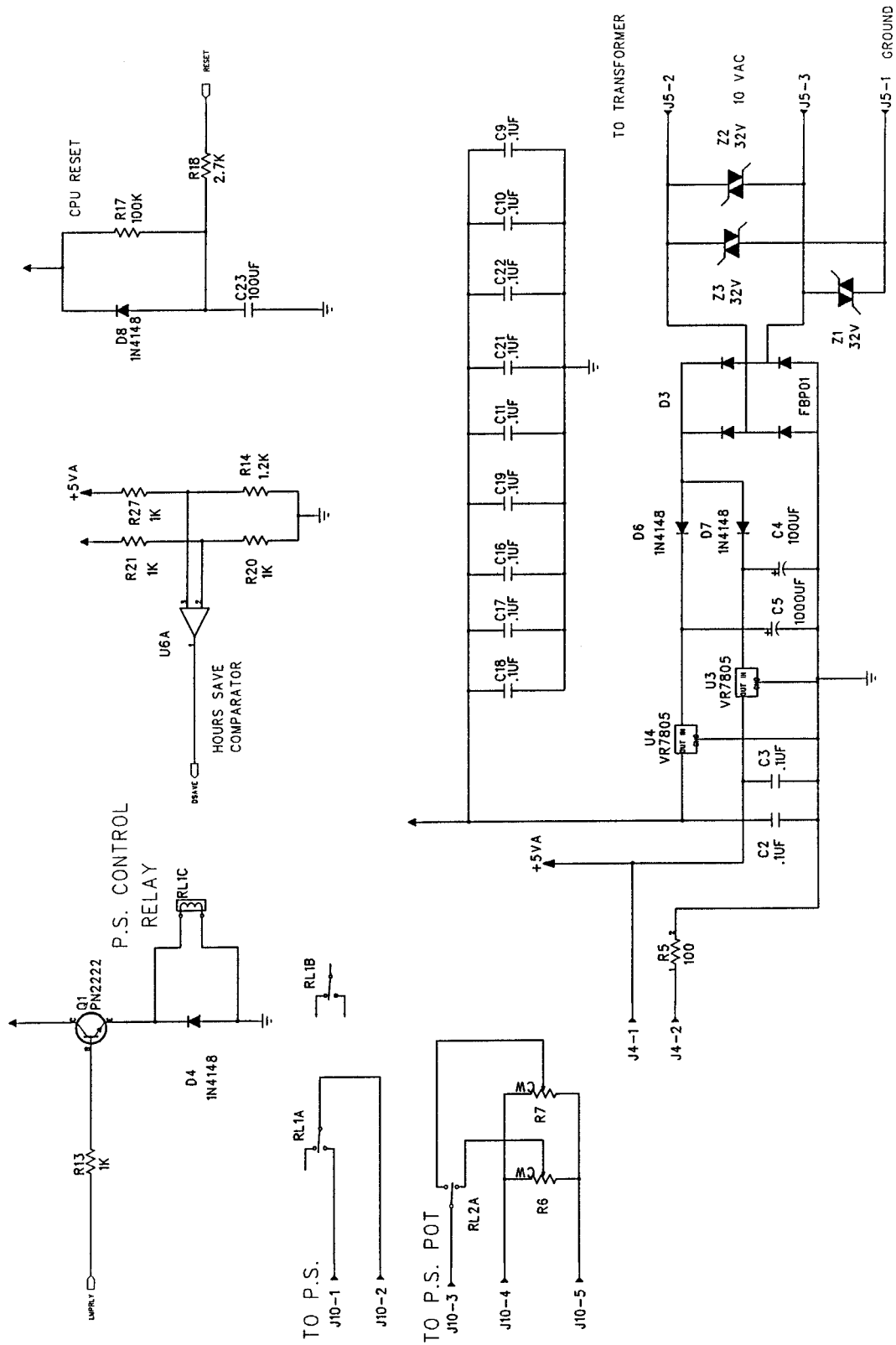

Wiring Diagram  
Page 2 of 3

23976 DIGITAL DISPLAY CONTROL PC BOARD

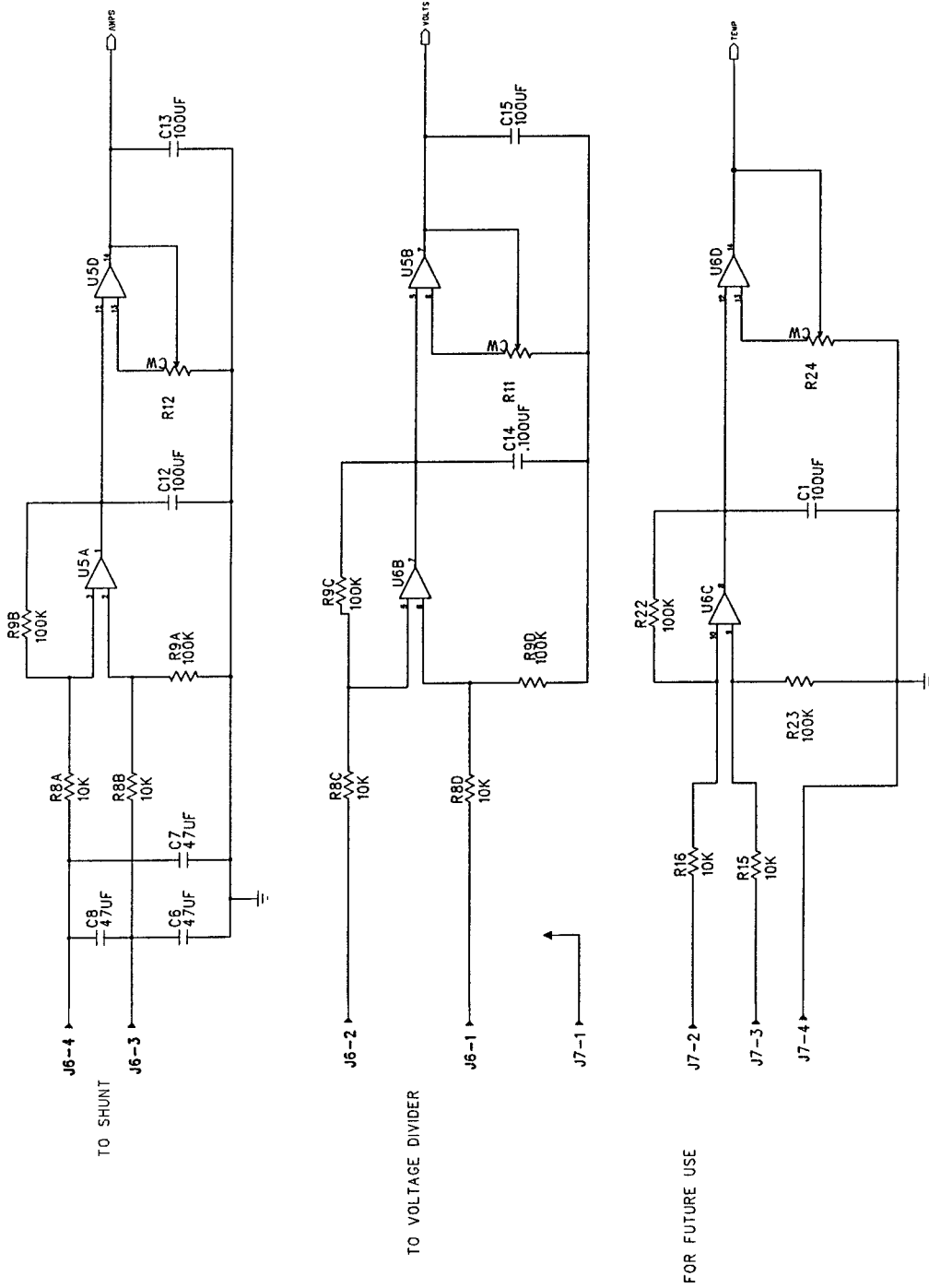

ANALOG CONTROL PANEL

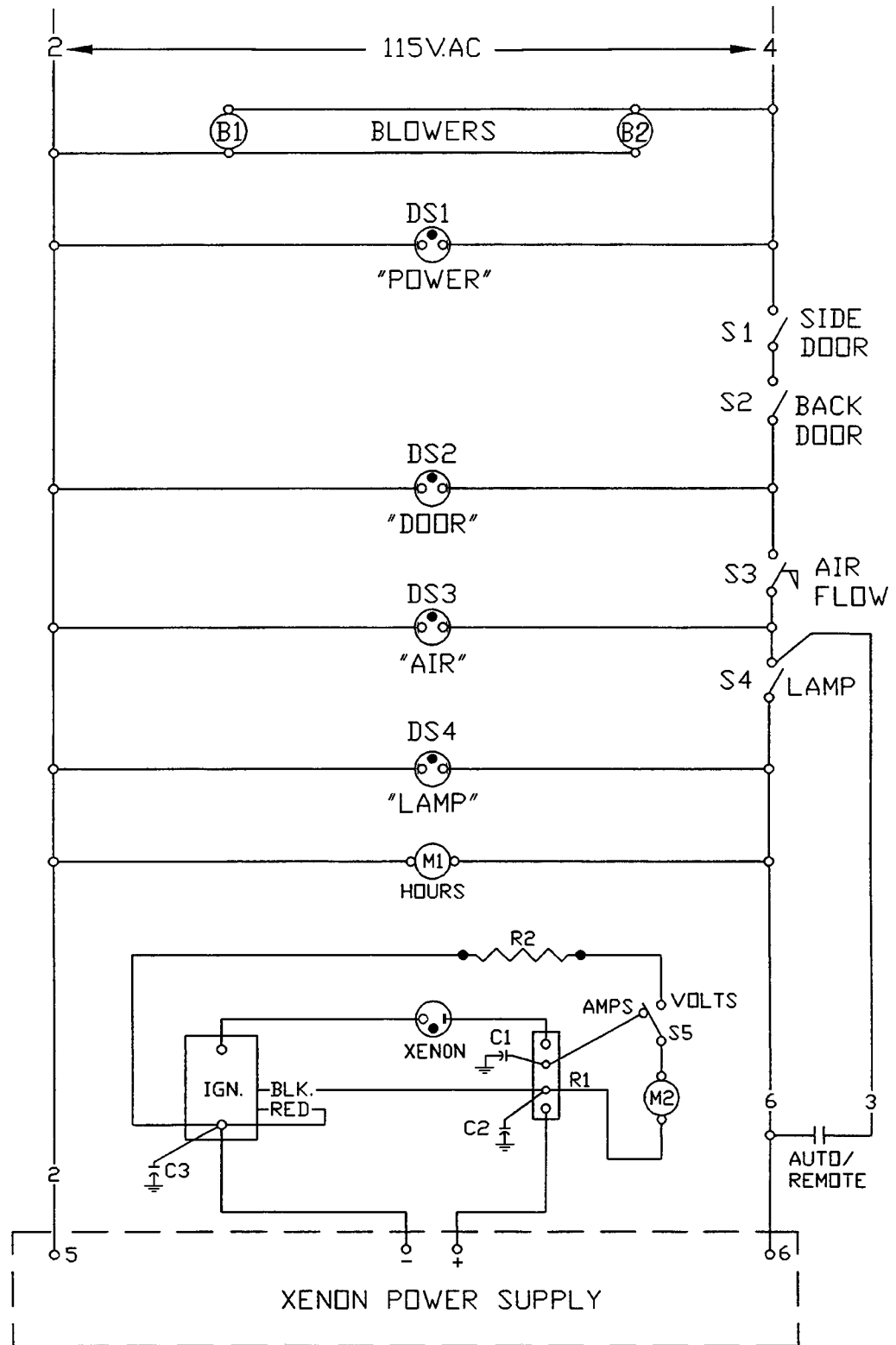

**PARTS LIST**  
Analog Control Panel

Ref.

<u>Desig.</u>	<u>Part No.</u>	<u>Description</u>
B1	25598	Front Blower Assembly, 115 V.AC, 50/60 Hz.
B2	25598	Front Blower Assembly, 115 V.AC, 50/60 Hz.
C1	31909	RF Suppression Capacitor, .01 $\mu$ f, 1000 V.DC
C2	76323	RF Suppression Capacitor, 2 x 1.0 $\mu$ f, 600 WVDC
C3	76323	RF Suppression Capacitor, 2 x 1.0 $\mu$ f, 600 WVDC
DS1	81-30002	POWER ON Indicator Light
DS2	81-30002	DOOR Indicator Light
DS3	81-30002	AIR Indicator Light
DS4	81-30002	LAMP ON Indicator Light
-	7056-0007	Lens Cap, Green
IGN	39862	DC Pulse Igniter Assembly
M1	2479-1216	Elapsed Time Meter, 60 Hz. (81-32001)
-	2479-1214	Elapsed Time Meter, 50 Hz. (81-32004)
M2	40191	Ammeter, 0-200 A.
R1	82167	Shunt, 150 A. 50 mV.
R2	21-46059	Resistor, 150k Ohm, 1/2 Watt
S1	24406	Magnetic Interlock Switch Assembly
S2	24406	Magnetic Interlock Switch Assembly
-	21-61007	Magnetic Actuator (for 24406)
S1,2	39260	Pushbutton Interlock Switch (Euro models)
S3	85109	Air Flow Switch
-	12-30538	Mounting Bracket, Air Flow Switch
-	39188	Air Paddle, Actuator Arm
S4	23869	Rocker Switch, LAMP
S5	23868	Rocker Switch, Momentary

S4, S5, and DS1-4 included with 24236 Printed Circuit Board Assembly.

## **TROUBLESHOOTING**

IN THE EVENT of an ignition failure, check first the messages on the digital display screen. It will read out items to inspect and possible conditions to correct.

The control circuit of the DPC operates on 230 V.AC. *Exercise extreme caution when taking readings inside the console enclosure.* Do not open the lamphouse enclosure until the bulb has cooled to room temperature and the power supply and igniter capacitors have drained for (10) minutes.

Observe all safety procedures when working around the xenon bulb. If the quartz envelope of the bulb is accidentally touched, remove all fingerprints with alcohol before igniting the bulb.

### NORMAL OPERATION:

The igniter operates from the high DC open circuit voltage furnished by the xenon power supply when energized. The 115 V.AC control circuit (5 & 6), which is energized when interlock and air flow switches are closed, and the LAMP ON closure is completed, actuates the xenon power supply. The igniter then generates the high voltage RF pulse to bridge the bulb arc gap. The RF pulse, combined with the high open circuit DC voltage, are necessary to ignite the bulb.

There will be a distinct buzzing sound at the moment the xenon bulb ignites. This is caused by the spark gap in the igniter, and the high voltage arc between the bulb electrodes.

A short delay (two to three seconds) between contactor closure and the ignition pulse is not abnormal. This delay allows power supply capacitors to charge. A similar delay between strikes is normal in the event multiple ignition pulses are needed; a "warm" bulb, or an old bulb nearing expiration, sometimes require more than one ignition pulse.

When the bulb ignites, the DC voltage drops to normal bulb operating range. The igniter ceases operation at voltages below 130 V.DC.

### TROUBLESHOOTING

#### **Bulb Fails To Ignite**

1. No DC current. Switch MAIN LINE breaker ON.
2. Low DC "no load" voltage from xenon power supply. Check no load voltage by observing voltage display. Repair or replace xenon power supply if "no load" voltage does not reach 140 V.DC.
3. Defective xenon bulb. Check for damaged or scorched electrodes, discolored quartz envelope or end caps. Replace if defective.



## **TROUBLESHOOTING** (continued)

### **Bulb Fails To Ignite** (continued)

4. Faulty igniter. Arc at spark gap should be audible, and arc across bulb electrodes should be visible through arc viewing port. Repair or replace igniter if arc is not apparent.
5. DC output level too low. Increase power supply to rated bulb current.
6. Faulty automation contact. If lamp ignites by means of the “LAMP” switch, but fails to ignite automatically, check automation controller.
7. Loose or faulty terminal connection. Visually inspect connections, particularly in AC circuit (5 & 6) and all DC connections.
8. Ignition pulse arcing to ground. Dress all igniter and bulb leads away from grounded metal lamphouse components.

### **Bulb Goes Out During Operation**

1. Blocked bulb seal blower intake or defective blower motor. Clean or replace.
2. Air flow switch sticking or faulty. Clean or replace.
3. Exhaust system malfunction. Check for correct exhaust blower operation; unobstructed air flow through ducting.
4. Overheated thermal switch in xenon power supply. Check for unobstructed air flow through power supply; loose DC connection(s).
5. Blower motor overheated, internal thermal switch open. Allow to cool; clean and oil as required.
6. Faulty automation contact. If lamp operates normally in “manual” mode (using “LAMP” switch), check automation controller relay.
7. Faulty xenon bulb. Check for damaged electrodes, darkened envelope, instability in operating current or voltage. Replace if defective.
8. Phase loss or unstable AC source. See xenon power supply manual; Strong switching power supplies feature *Phase Loss Detection* and *Brown-Out Protection* circuits.

### **Excessive Light Flicker**

1. Defective xenon bulb. Check for cracked and/or sagging electrode.
2. Arc stabilization magnet missing or reversed. Replace or correct.
3. Rectifier diode open or shorted (high reactance supply). Replace as required.
4. Excessive ripple in power supply DC output. Consult factory.

## TROUBLESHOOTING (continued)

### Reduced Light Output

1. Normal bulb aging. Increase current. Do not exceed maximum current rating specified by xenon bulb manufacturer.
2. Defective bulb. Check for discoloration or premature darkening of envelope.
3. Bulb defocused or misaligned.

### Noise in Theatre Sound System During Bulb Ignition or Operation

1. Defective RF suppression capacitor on Voltage Divider PCB. Check with capacitor tester and replace if defective.
2. Console or sound system not correctly grounded. Connect to adequate earth ground.



#### NOTICE



The Strong DC Pulse Igniter stores energy in its capacitors *after* the console has been de-energized. To prevent shock, this energy can be discharged by placing the blade of an insulated-handle screwdriver across the metal end caps of the spark gap.

The Strong switching-type Xenon Power Supply employs solid state circuitry requiring sophisticated diagnostic equipment not generally available to field service personnel. If an ignition problem in the TROUBLE CHART section is traced to this unit, contact an authorized Strong International Dealer for further information.

FIGURE 1

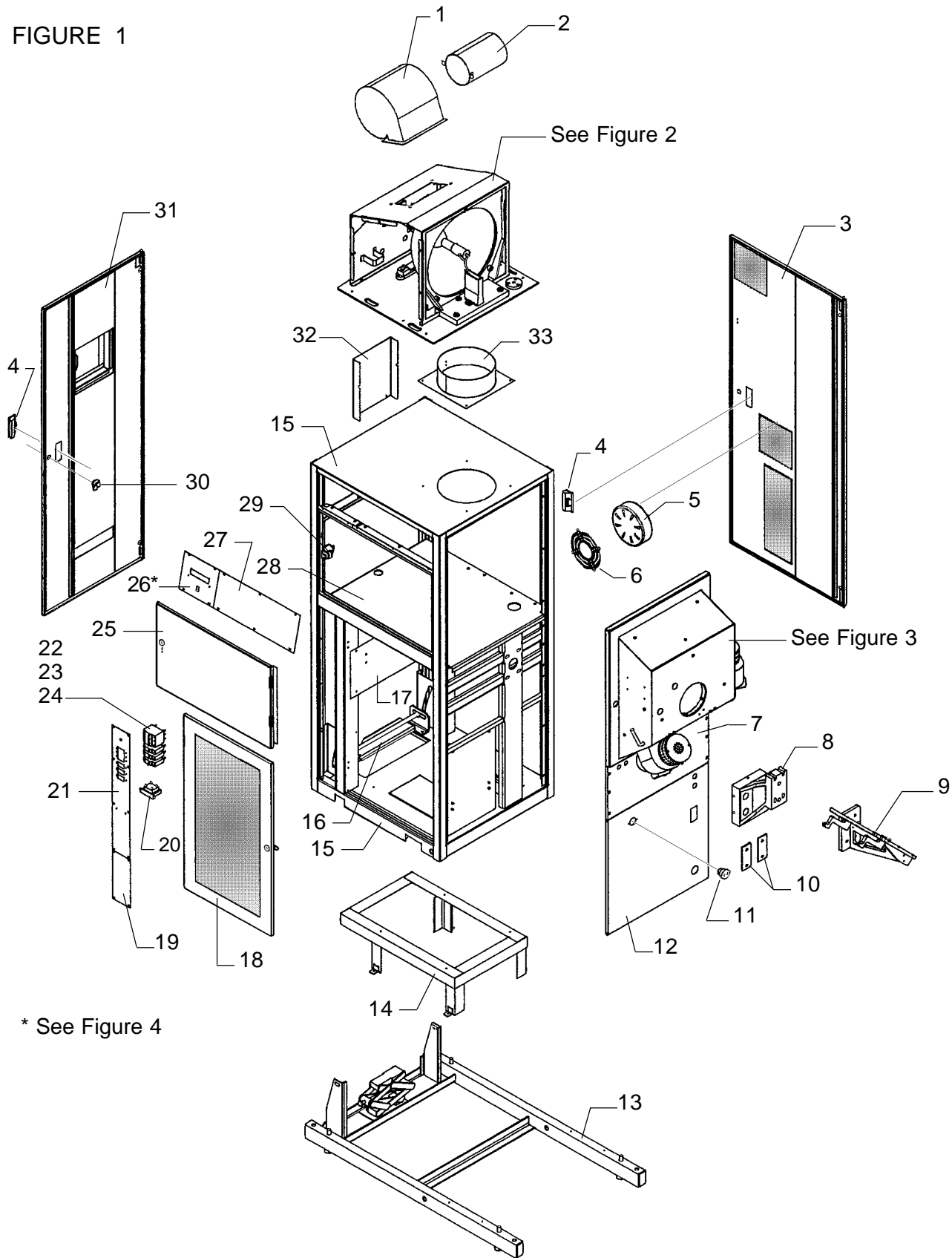

## PARTS LIST

Figure 1

<u>Item</u>	<u>Part No.</u>	<u>Description</u>
1	11-33008	Squirrelcage Blower, 230 V.AC, 50/60 Hz.
-	4080370	Mounting Screw, 8-32 x 3/8" Pan Head
-	85109	Air Flow Switch (not shown)
-	24419	Air Vane Paddle (not shown)
-	25188	Bracket, Air Flow Switch (not shown)
2	25577	Blower Intake Duct, Welded Assembly
3	25507	Off-Operator Side Door & Hinge Assembly
4	25214	Pull Handle, Black Plastic
5	71627	Blower, 230 V.AC, 50/60 Hz.
-	4082750	Mounting Screw, 8-32 x 2-3/4" Pan Head
-	4087101	Flatwasher, #8
-	4088001	Hexnut, 8-32
-	4087004	Lockwasher, #8
6	71307	Blower Grille (2 req'd.)
7	25534	Base Plate, Projector Mount
-	4251002	Plate Mounting Screw, 1/4-20 x 1" Socket Head
-	4258001	Hexnut, 1/4-20
-	4257001	Lockwasher, 1/4"
-	71221	Nut Plate (not shown; concealed by Item 8)
-	01778000	Plate Mounting Screw, 5/16-18 x 1-3/4" Flat Head (4 req'd.)
-	4317000	Lockwasher, 5/16" (4 req'd.)
-	4318001	Hex Nut, 5/16-18 (4 req'd.)
8	72-00001	Projector Support Arm Casting
-	4371505	Mounting Screw, 3/8-16 x 1-1/2" Hex Head (4 req'd.)
-	4377001	Lockwasher, 3/8" (4 req'd.)
-	4377103	Flat Washer, 3/8" (4 req'd.)
9	72-00009	Digital Projector Mounting Bracket
-	4371750	Mounting Screw, 3/8-16 x 1-3/4" Hex Head (4 req'd.)
-	4377001	Lockwasher, 3/8" (4 req'd.)
-	4377103	Flat Washer, 3/8" (4 req'd.)
10	71240	Slide Bar (2 req'd.)
11	11-40019	Twistlock Plug
-	4060501	Mounting Screw, 6-32 x 1/2" Flat Head
12	25536	Lower Front Panel
-	4100621	Mounting Screw, 10-32 x 5/8" Pan Head
13	25529	Base Frame, Welded Assembly
-	71184	Leveling Foot (4 req'd.)
14	72-00032	Power Supply Support, Welded Assembly
-	4250503	Mounting Screw, 1/4-20 x 1/2" Hex Head
15	25509	Console Frame, Welded Assembly
-	31129	Pivot Shaft (not shown)
16	31993	Jack Swivel Bracket, Welded Assembly
17	25557	Divider Plate

**PARTS LIST, Figure 1 (continued)**

<u>Item</u>	<u>Part No.</u>	<u>Description</u>
18	25511	Power Supply Access Door & Hinge Assembly
19	31163	Pivot Lock Cover Plate
20	25173	Transformer, Digital Display
21	25603	Distribution Panel Wired Assembly
-	25566	Panel (less Components)
22	81-61041	Circuit Breaker, 50 A. 3 Pole
23	25345	Circuit Breaker, 5 A
24	25347	Circuit Breaker, 10 A.
-	25348	Circuit Breaker, 15 A. (as req'd.)
25	25508	Lamphouse Access Door & Hinge Assembly
26	25574	Digital Control Panel (see Figure 4)
26	31946	Analog Control Panel (see Figure 4)
-	31953	Hinge
27	31133	Cover Panel, Blank
-	25579	Hinge
28	25558	Sub Plate, Lamphouse Burner Plate
-	4100751	Mounting Screw, 10-32 x 3/4" Pan Head
29	24406	Door Interlock Switch Assembly
30	71284	Cam Lock & Keys (4 req'd)
31	25510	Rear Door & Hinge Assembly
32	11061	Blower Support Bracket
-	4080504	Mounting Screw, 8-32 x 1/2" Pan Head
33	25550	Exhaust Stack, 9 inch
-	4080370	Mounting Screw, 8-32 x 3/8" Pan Head
-	4088001	Hexnut, 8-32
-	4087004	Lockwasher, #8

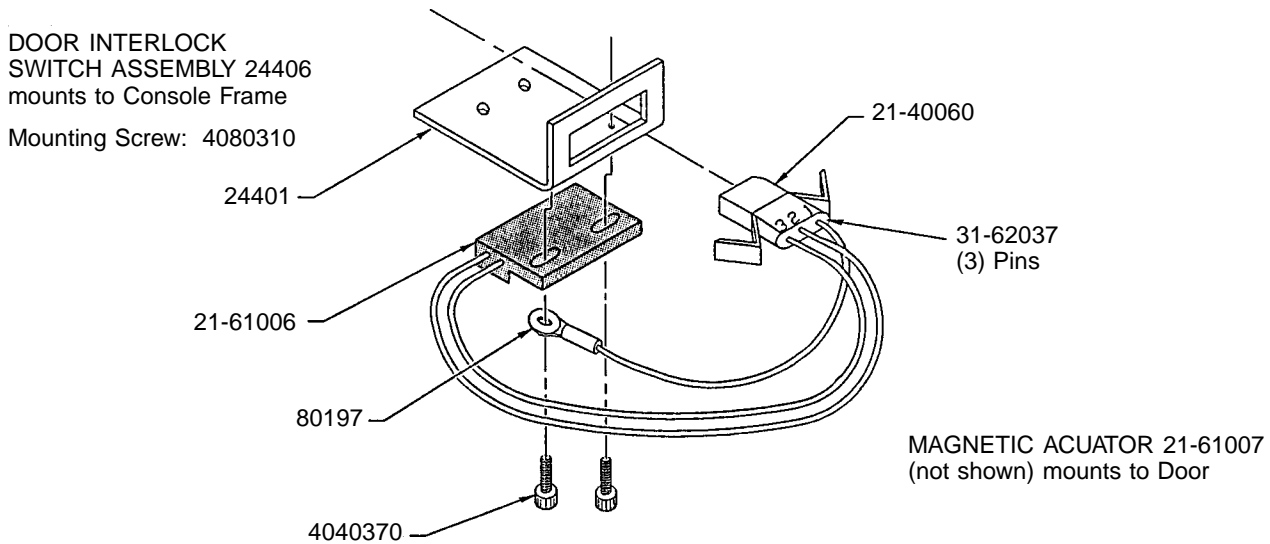
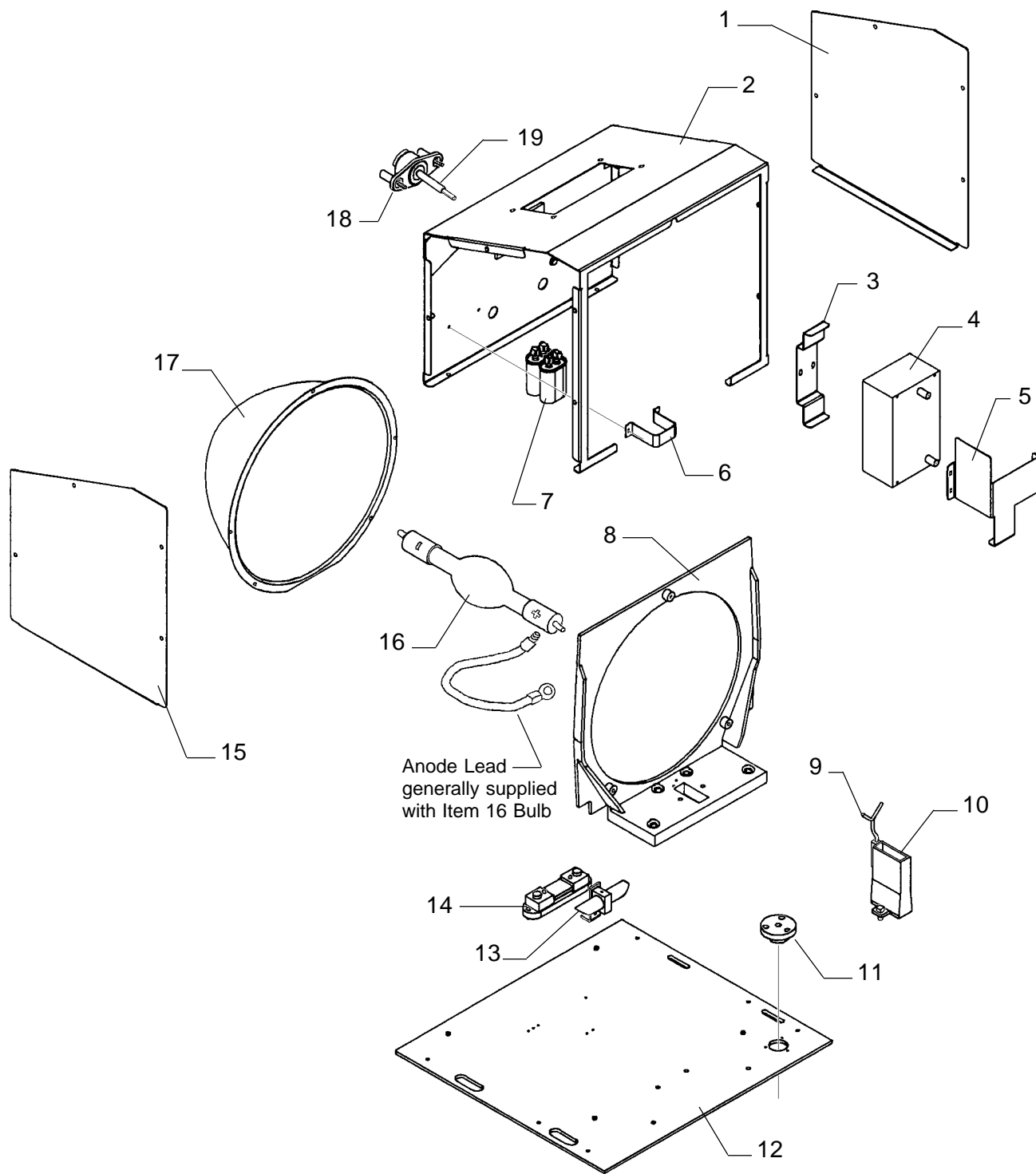

FIGURE 2



## PARTS LIST

Figure 2

<u>Item</u>	<u>Part No.</u>	<u>Description</u>
1	25584	Bulb Enclosure Side Cover, Left
-	31875	Thumb Screw (not shown)
-	4108021	Tinnerman Nut, #10 (not shown; mounts to Item 2)
2	25562	Bulb Enclosure Housing, Welded Assembly
-	4110501	Mounting Screw (to Item 12), 10-24 x 1/2" Pan Head
3	23790	Igniter Mounting Bracket, Inner
-	4250503	Mounting Screw, 1/4-20 x 1/2" Hex Head
-	4257000	Lockwasher, 1/4" Split Ring
-	4258001	Hexnut, 1/4-20
4	39862	DC Pulse Igniter Assembly
-	39875	Igniter Case & Coil, Potted Assembly
-	25476	Igniter Printed Circuit Board Assembly
5	25535	Igniter Mounting Bracket, Outer
-	4250503	Mounting Screw, 1/4-20 x 1/2" Hex Head
-	4257000	Lockwasher, 1/4" Split Ring
-	4258001	Hexnut, 1/4-20
6	76208	Capacitor Clamp
-	4080375	Mounting Screw, 8-32 x 3/8" Bind Head
7	76353	Capacitor, 10 $\mu$ f, 370 V.AC
8	40104	Reflector Bulkhead Casting
-	4370750	Bulkhead Mounting Screw, 3/8-16 x 3/4" Hex Head
-	4377000	Lockwasher, 3/8" Split Ring
-	4378001	Flatwasher, 3/8"
-	4371750	Bulkhead Mounting Screw, 3/8-16 x 1-3/4" Hex Head
-	4377000	Lockwasher, 3/8" Split Ring
-	4378001	Flatwasher, 3/8"
9	70162	Bulb Support Yoke, Welded Assembly
-	4108001	Hexnut, Height Adjust Lock
-	4080259	Set Screw, 8-32 x 1/4"
10	40107	Bulb Pedestal Casting
-	4310750	Mounting Screw, 5/16-18 Nylon
-	23980	Insulator Plate (not shown)
11	81301	Insulator, Positive Binding Post
-	4110500	Mounting Screw, 10-24 x 1/2" Socket Head
-	24263	Positive Lead Assembly, Feed-Through (not shown)
-	4378006	Hexnut, 3/8-16 Brass (not shown)
-	4377100	Flatwasher, 3/8" Brass (not shown)
12	25559	Lamphouse Burner Plate
-	4311750	Tie-Down Screw, 5/16-18 x 1-3/4" Socket Head
-	23912	Fender Washer
-	4311752	Burner Plate Adjusting Screw, 5/16-18 x 1-3/4" Headless
-	4318001	Lock Nut, 5/16-18

**PARTS LIST, Figure 2 (continued)**

<u>Item</u>	<u>Part No.</u>	<u>Description</u>
13	00M15315	Arc Stabilization Magnet
-	81137	Magnet Clamp
-	4080259	Set Screw, 8-32 x 1/4"
-	71424	"L" Bracket, Magnet Clamp
-	4080310	Mounting Screw, 8-32 x 5/16" Pan Head
14	81247	Shunt, 200 A. 50 mV.
-	4110622	Mounting Screw, 10-24 x 5/8" Socket Head
-	4107001	Lockwasher, #10
-	24275	Voltage Divider PC Board (not shown)
15	25563	Bulb Enclosure Side Cover, Right
-	31875	Thumb Screw (not shown)
-	4108021	Tinnerman Nut, #10 (not shown; mounts to Item 2)
16	--	Xenon Bulb (by Customer)
17	25612	Reflector, 15.325" Diameter
-	81-51004	Shoulder Screw, 3/8" 5/16-18 Thrd.
18	65827	Bulb Adjustment Assembly (less Item 19 Collet)
19	*	Bulb Support Collet

\* See Page 39

**65827 BULB ADJUSTMENT MECHANISM**

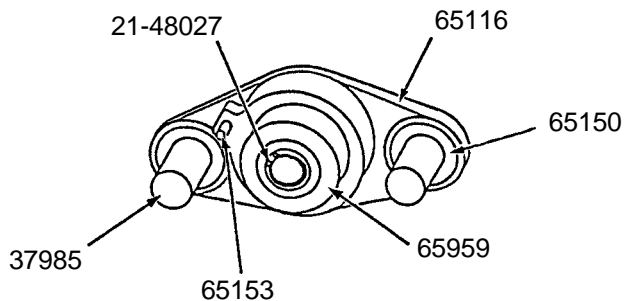

- 37985 Thumb Screw (2 req'd.)
- 15010 Compression Spring (2 req'd.)
- 65116 Casting, Adjustment Mechanism
- 65150 Fender Washer (2 req'd.)
- 65153 Focus Lockscrew
- 65154 Nylon Locking Ball
- 65959 Focus Screw & Bearing Assembly
- 21-48027 Snap Ring, Collet Retaining



FIGURE 3

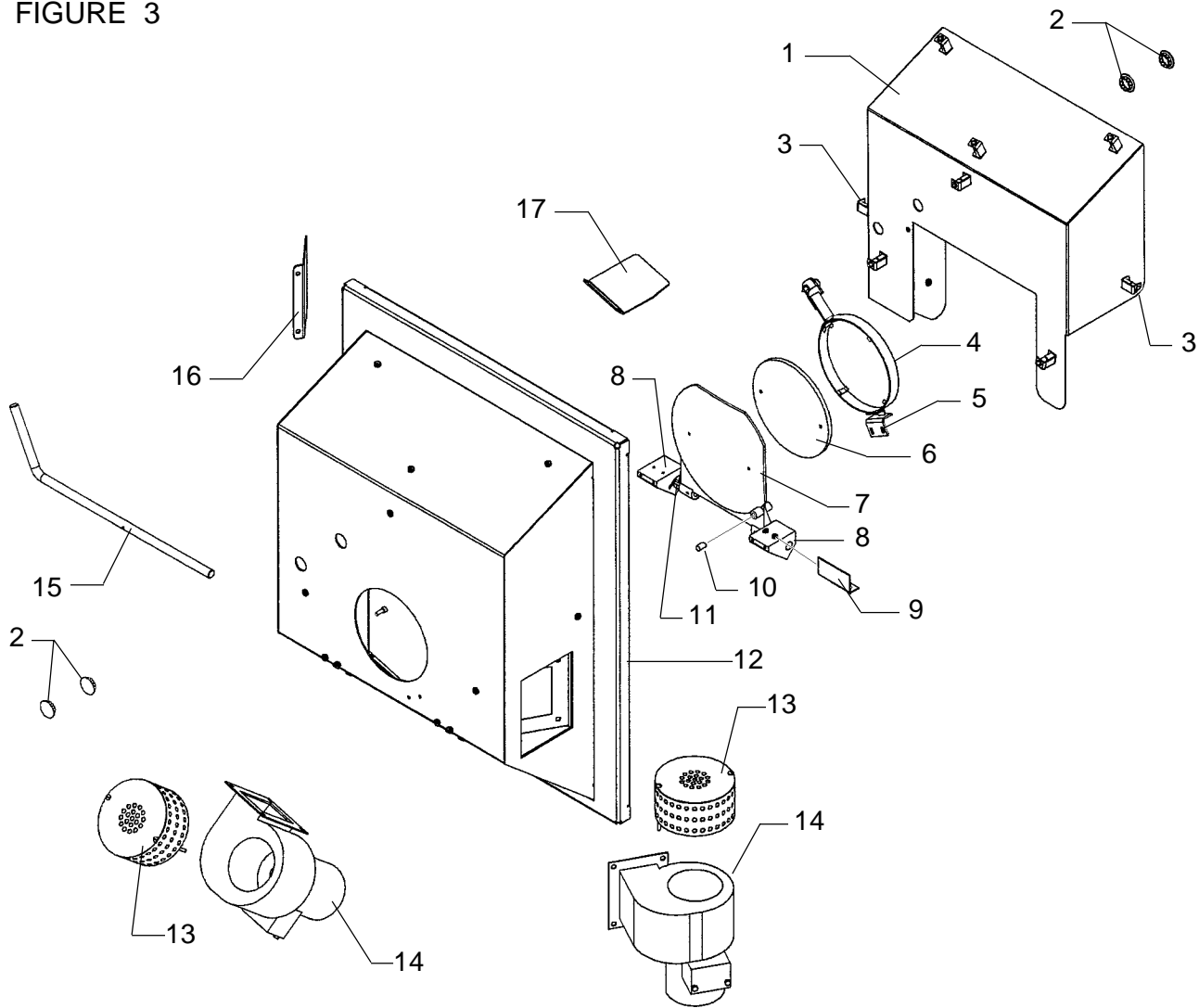

**PARTS LIST**

Figure 3

<u>Item</u>	<u>Part No.</u>	<u>Description</u>
1	25545	Douser Heat Shield, Welded Assembly
-	4100375	Mounting Screw, 10-32 x 3/8" Phillips
2	57275	Plug Button, Chromed
3	25549	Heat Shield Spacer (9 req'd.)
-	4100375	Mounting Screw, 10-32 x 3/8" Phillips
4	25567	Filter Ring Welded Assembly
-	40180	Heat Filter, Glass; 5½" Diameter
-	25396	Mounting Screw
5	25555	Filter Mounting Bracket
-	4080370	Mounting Screw, 8-32 x 3/8" Pan Head
-	4088001	Hex Nut, 8-32
-	4087004	Lockwasher, #8

**PARTS LIST, Figure 3 (continued)**

<u>Item</u>	<u>Part No.</u>	<u>Description</u>
6	72-00005	Douser Heat Shield, Ceramic
-	4100500	Mounting Screw, 10-32 x 1/2" Socket Head
7	81148	Douser Plate Casting
-	81432	Shoulder Screw (attaches Plate to Item 15 Shaft)
8	25546	Douser Arm Block (2 req'd.)
-	4100375	Mounting Screw, 10-32 x 3/8" Pan Head
9	25556	Douser Stop Bracket
-	4080370	Mounting Screw, 8-32 x 3/8" Pan Head, Black Oxide
10	81234	Rubber Bumper
11	81187	Torsion Spring, Douser Shaft
12	25537	Douser Housing, Welded Assembly
-	4100503	Mounting Screw, 10-32 x 1/2" Pan Head
13	72-00004	Blower Intake Guard, Welded Assembly
-	4083000	Mounting Screw, 8-32 x 3" Round Head
14	25598	Front Blower Assembly
-	4250623	Mounting Screw, 1/4-20 x 5/8" Hex Head
-	4257001	Lockwasher, 1/4"
-	4258001	Hexnut, 1/4-20
15	25614	Douser Shaft & Handle
-	45150A	Handle Grip, Red Plastic (not shown)
16	25548	Air Baffle Bracket, 70°
-	4250623	Mounting Screw, 1/4-20 x 5/8" Hex Head
17	25547	Air Baffle Bracket, 47°
-	4250623	Mounting Screw, 1/4-20 x 5/8" Hex Head

FIGURE 4

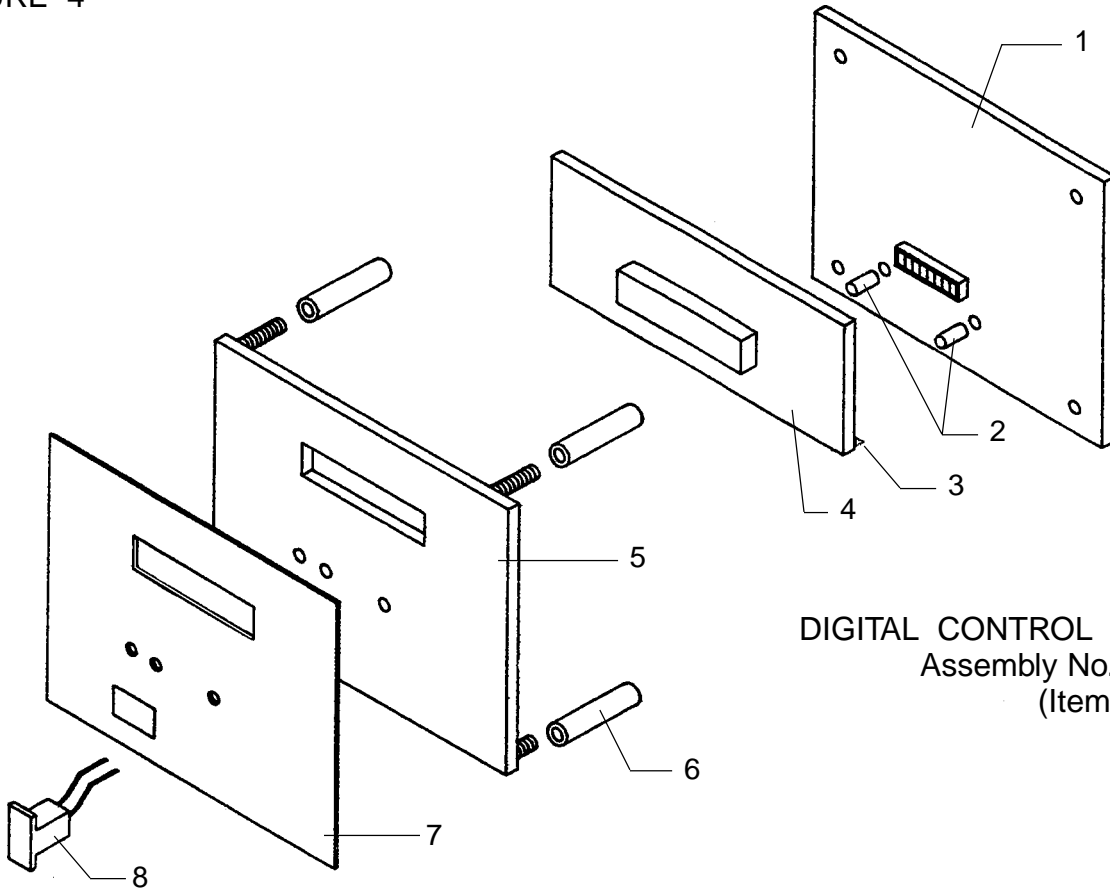

DIGITAL CONTROL PANEL  
 Assembly No. 25574  
 (Items 1 - 8)

ANALOG CONTROL  
 PANEL  
 Assembly No. 31946  
 (Items 9 - 15)

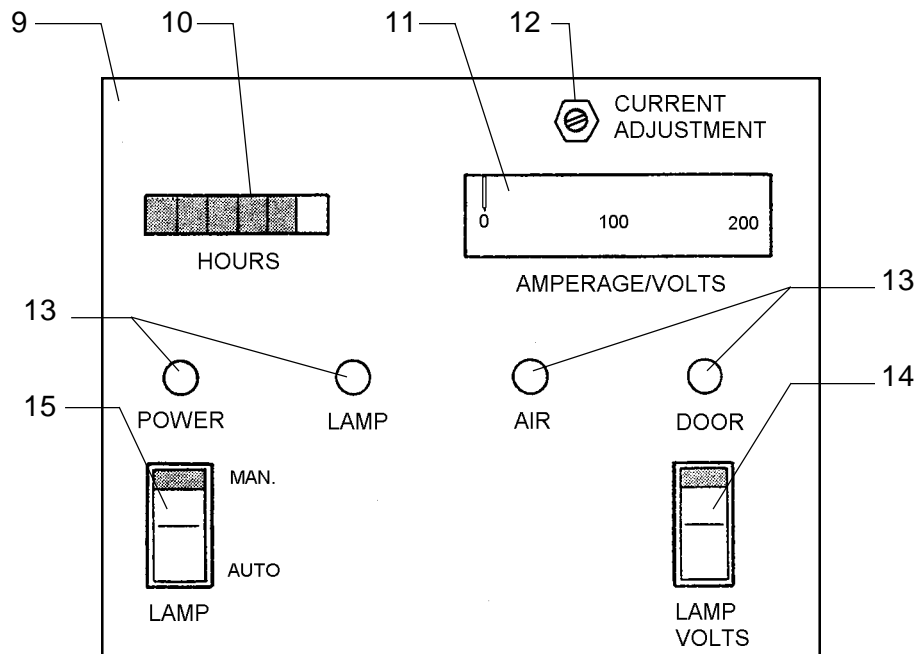

## PARTS LIST

Figure 4

<u>Item</u>	<u>Part No.</u>	<u>Description</u>
1	23976	Printed Circuit Board Assembly, Digital Control
2	61-98022	Standoff, 6-32 x 1/2" Brass (2 req'd.)
3	71-40019	Pin Header
4	24087	LCD Display Assembly
5	23975	Control Panel Plate (less Components)
6	21-98543	Standoff, 1-1/8" Aluminum (4 req'd.)
7	23927	Overlay, Adhesive Backed
8	24086	LAMP Switch Assembly
9	31122	Control Panel Plate (less Components)
10	2479-1216	Elapsed Time Meter, 60 Hz.
10	2479-1215	Elapsed Time Meter, 50 Hz. (Euro)
11	40191	Ammeter, 0-200 A. 50 mV.
12	62-70032	Current Control & Cable Assembly
-	61-69002	Potentiometer (only), 10k Ohm
13	81-30002	Light Emitting Diode (4 req'd.)
-	7056-0007	Green Cap
14	23868	Rocker Switch, Momentary
15	23869	Rocker Switch, LAMP
-	24236	Printed Circuit Board Assembly (incl. Items 13,14, & 15)

## REAR BULB SUPPORT COLLET ASSEMBLY

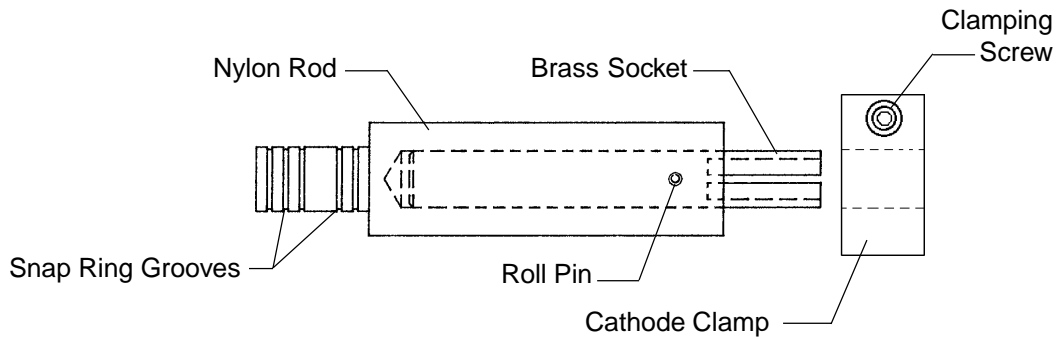

<u>Bulb Wattage</u>	<u>Collet Part No.</u>	<u>Overall Length</u>	<u>Socket Diameter</u>	<u>Clamp Part No.</u>	<u>Clamping Screw</u>
2000 & below	72-00064	4-1/2" (11.4cm)	.475" (12mm)	65131	4080870
2000, 3000 "HS"	72-00142	4-11/16" (11.9cm)	.312" (8mm)	40965	4080870
2500 "HS"	72-00142	4-11/16" (11.9cm)	.312" (8mm)	40965	4080870
3000	72-00065	3-5/8" (9.2cm)	.551" (14mm)	40966	4080870
4000-4500 "HS"	72-00066	3-1/2" (8.9cm)	.312" (8mm)	40965	4080870
5000	72-00067*	3-7/8" (9.8cm)	.710" (18mm)	24430	4101000
6000, 7000 "HS"	72-00066	3-1/2" (8.9cm)	.312" (8mm)	40965	4080870
3000-7000 "H/VC"	72-00065	3-5/8" (9.2cm)	.551" (14mm)	40966	4080870

\* Osram XBO5000W/H OFR; other 5 kW types, *consult Factory*  
 2000, 2500, & 3000 watt "HS" bulbs require Anode Adapter 40293

Anode Adapters required for 1000, 1600, 2000, 2500 & 3000 watt bulbs "HS" type only.  
 See preceding DPC XENON BULBS section for adapter Part Numbers.



