

# Film-Tech

The information contained in this Adobe Acrobat pdf file is provided at your own risk and good judgment.

These manuals are designed to facilitate the exchange of information related to cinema projection and film handling, with no warranties nor obligations from the authors, for qualified field service engineers.

If you are not a qualified technician, please make no adjustments to anything you may read about in these Adobe manual downloads.

[www.film-tech.com](http://www.film-tech.com)

# PARTS CATALOG

*Norelco*<sup>®</sup>

**UNIVERSAL 70/35**

**PROJECTOR**



*Motion Picture Equipment Division,*

**NORTH AMERICAN PHILIPS COMPANY, INC.**

100 East 42nd Street, New York, 17, N.Y. Phone: Oxford 7-3600



BEN KEHE  
21519 EAST 33RD STREET SOUTH  
BROKEN ARROW, OKLAHOMA 74014-1159

# PARTS CATALOG

## INDEX

Fig. No.		Page No.
1	Frontispiece .....	2-3
2	Projector Head - General .....	4-5
3	Upper Base, Lower Base, Arc Lamp Bracket, and Lower Magazine .....	6-7
4	Upper Magazine and Fire Trap .....	8
5	Motor Drive Assembly .....	9
6	Shutter Shaft Assembly .....	10-11
7	Lens Bracket Assembly .....	12
8	Intermittent Mechanism .....	13
9	Film Buckle Switch and Levers .....	14-17
10	70mm Film Gate and Pad Rollers .....	15-18
11	35mm Film Gate and Pad Rollers .....	18-19
12	Cooling Plate .....	20-21
13	Cooling Plate Holder Assembly .....	22-23
14	Magnetic Soundhead .....	23-24
15	Optical Soundhead .....	25
16	Optical Preamplifier .....	26-27
17	Take-Up Drive Assembly .....	28-29
18	Guide Roller, Film Strippers and Framing Shaft Assembly .....	30-31
19	Bracket Assemblies; Upper Feed, Intermediate, and Hold-Back Sprockets .....	32-33
20	Oil Pump and Motor Drive Shaft .....	34-35
21	Main Shaft Assembly .....	36
22	Water Manifolds and Flow Switch .....	37
23	Electrical Components I .....	38-39
24	Electrical Components II .....	40-41
25	35mm Conversion Parts and Chest .....	

## ORDERING INSTRUCTIONS

Minimum acceptable order is five dollars (\$5.00). All prices shown are F.O.B. Factory or Warehouse.

All prices are subject to change without notice.

NOTE: This price list supersedes all previous price lists.

The following exploded views and parts lists cover replaceable parts for the NORELCO projector. When ordering replaceable parts, always indicate the serial number of the projector which appears on the name plate either on the arc lamp side of the projector head, or near the oil drain plugs. Be sure to include the name and complete part number of the part or assembly as it appears in the parts list. Items that are components of an assembly or group are indented under the assembly or group listing. All listed items carrying individual part numbers may be purchased separately. Components of certain assemblies cannot be purchased separately.

It is not recommended that field repairs be attempted on units listed as assemblies in the parts list. Some of these assemblies are factory adjusted and timed and any deviation from the required setting may result in faulty operation of the projector.

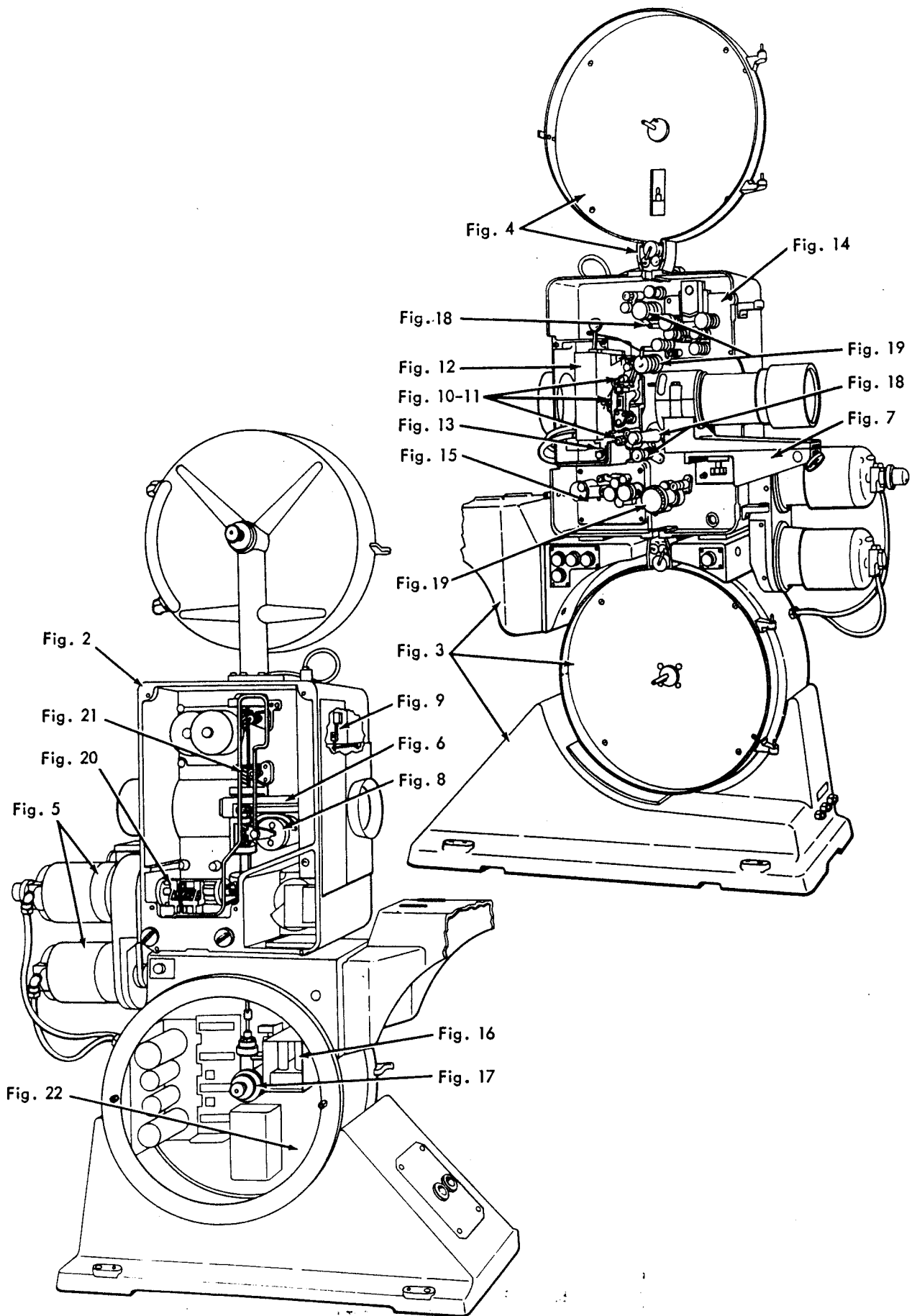

Figure 1. Parts Identification Illustration.

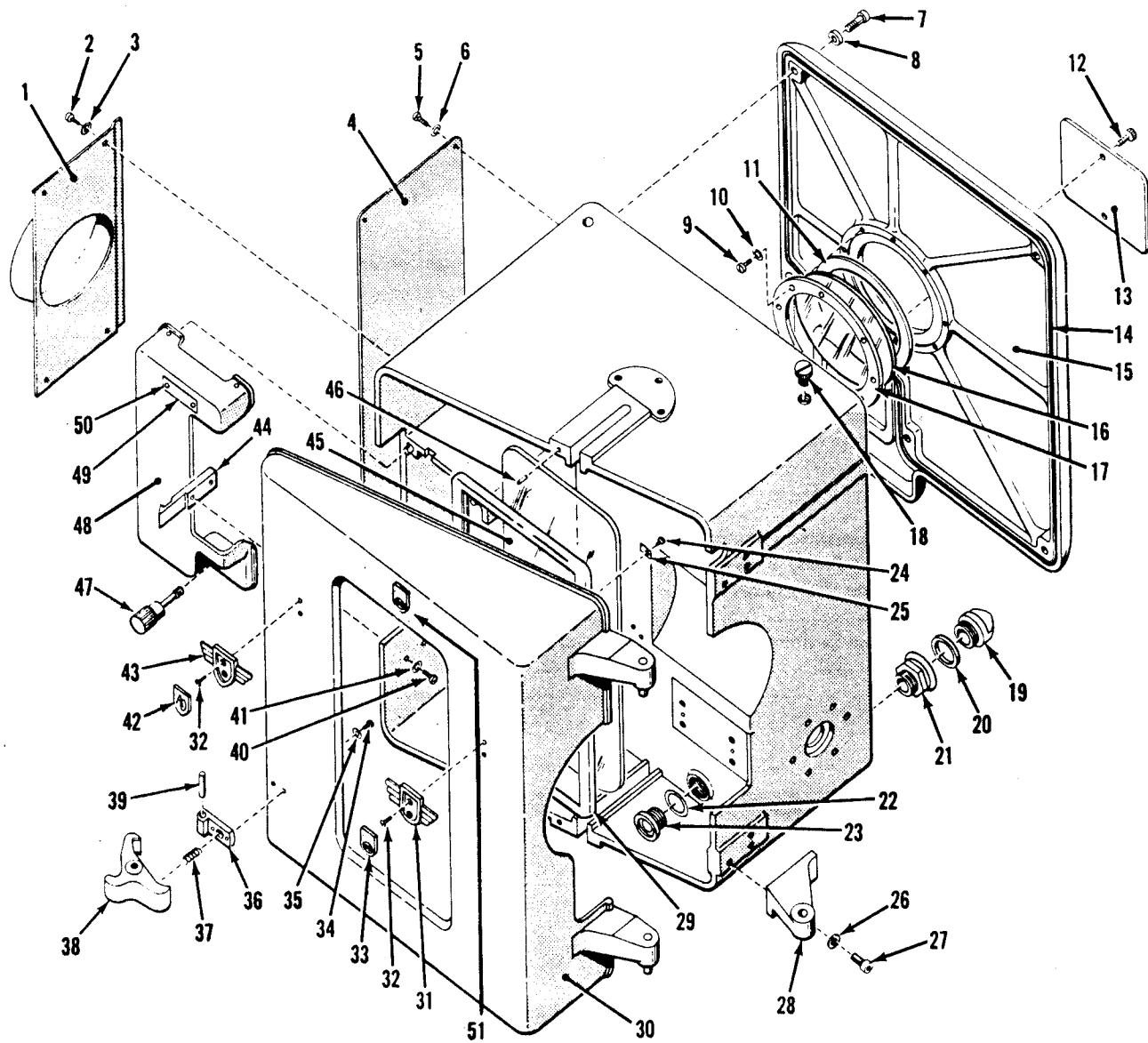

Figure 2. Projector Head - General.

PROJECTOR HEAD - GENERAL

Index No.	Description	Part No.	Qty. Req'd.
1	Rear cover, right-hand	C1 703 66	1
2	Screw	X-978-4	4
3	Washer	X-16015-4	4
4	Rear cover, left-hand	C1 703 67	1
5	Screw	X-18206-4	3
6	Washer	X-16020-4	3
7	Screw	X-19646	5
8	Washer, nylon	P5 635 33	5
	Back cover assembly	C1 050 82	1
9	Screw	X-18206-2	8
10	Washer	X-16020-2	8
11	Gasket	C1 050 79	1
12	Captive screw	C1 050 80	2
13	Cover	C1 050 81	1
14	Rubber gasket	C1 050 43	1
15	Back cover	C1 050 76	1
16	Window	P5 635 20	1
17	Clamping ring	C1 050 78	1
18	Oil filler plug	C1 703 70	1
19	Plug	C1 750 62	2
20	Gasket	22 456 03	2
21	Spout	C1 704 26	2
22	Gasket	22 456 03	1
23	Oil window assembly	C1 703 73	1
	Door and hinge group	C1 902 07	1
24	Screw	X-966-4	8
25	Clip	22 524 79	8
26	Lockwasher	X-16315	6
27	Screw	X-19532	6
28	Hinge	C1 902 05	2
29	Mounting rubber	C1 607 58	1
30	Door and hinge pin assembly	C1 705 61	1
31	Shield holder (Philips)	C1 509 55	1
32	Screw	X-1456-2	4
33	Shield (Philips)	V3 339 00	1
34	Screw	X-978-4	2
35	Lockwasher	X-16309	2
36	Hinge, latch	C1 902 06	1
37	Spring, latch	22 452 69	1
38	Latch	22 452 73	1
39	Hinge pin	B 042 AA/5X24	1
40	Screw	X-18218-4	2
41	Lockwasher	X-16312	2
42	Shield (AO)	C1 408 27	1
43	Shield holder (AO)	C1 408 28	1
44	Strike	C1 050 36	1
45	Window	P5 635 23	1
46	Rubber bumper	22 443 85	2
47	Captive screw, knurled	C1 703 63	1
48	Cover	C1 703 62	1
49	Threading position instruction plate	C1 704 27	1
50	Screw	X-786-4	2

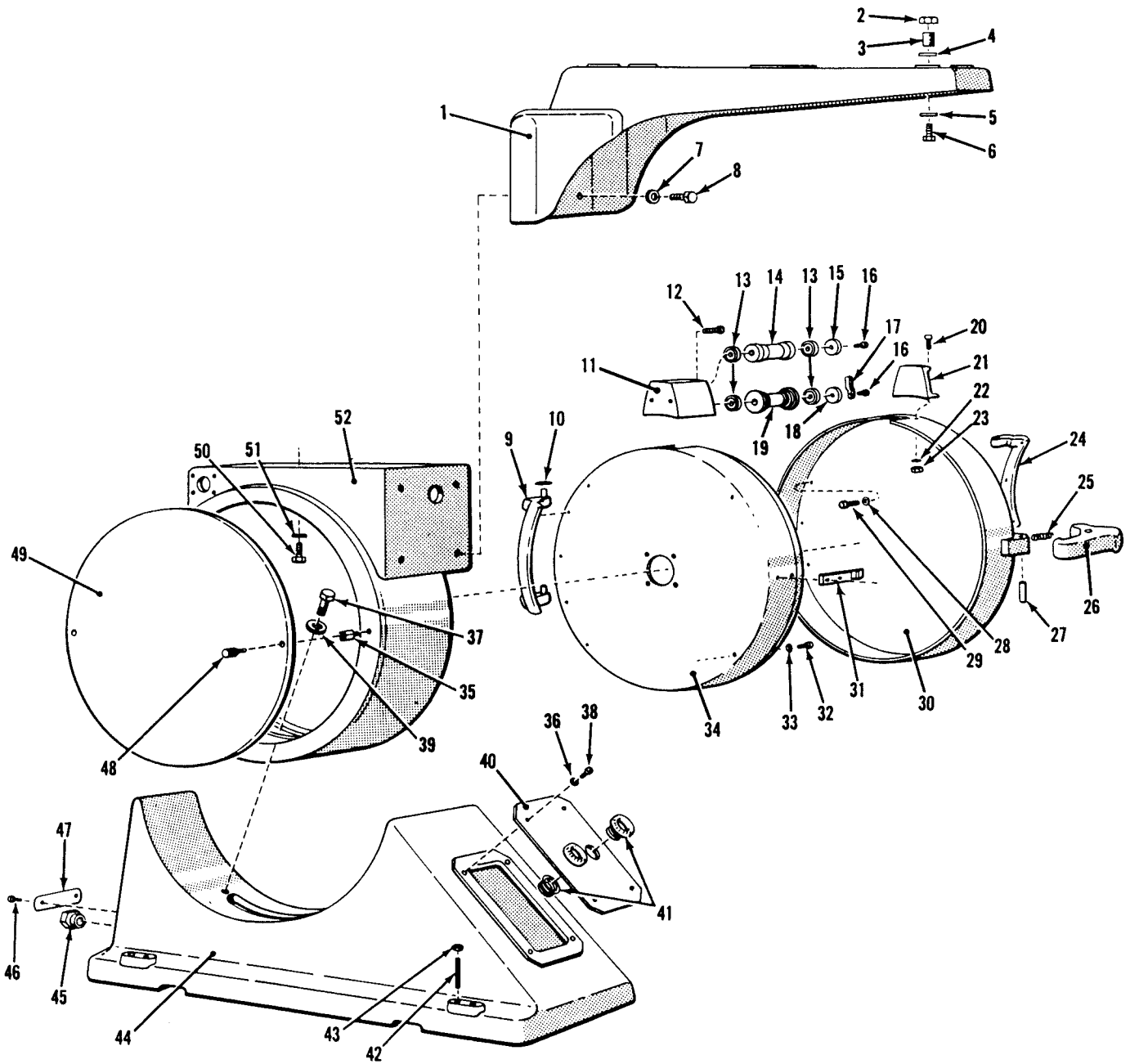

Figure 3. Upper Base, Lower Base, Arc Lamp Bracket, and Lower Magazine.

UPPER BASE, LOWER BASE, ARC LAMP BRACKET, AND LOWER MAGAZINE

Index No.	Description	Part No.	Qty. Req'd.
	Arc lamp bracket group	3041	1
1	Arc lamp bracket	3041-1	1
2	Nut	X-8025-2	4
3	Spacer	3041-2	4
4	Shims	01286-2	12
5	Washer	X-16025-2	4
6	Cap screw	3041-3	4
7	Washer	X-16060-2	4
8	Screw	X-5862-2	4
9	Magazine hinge	3030-860	1
10	Washer	3030-43	2
11	Fire trap housing	3030-861	1
12	Screw	X-20072-2	2
13	Ball bearing	3030-11	6
14	Roll (Standard)	3030-58	2
	Roll (For 35mm nitrate film)	3033-1	2
15	Bearing retainer	3030-59	2
16	Screw	X-972-2	3
17	Strap	3030-62	1
18	Bearing retainer, slotted	3030-60	1
19	Flanged roll (70 & 35mm)	3031-1	1
20	Screw	X-18218-4	2
21	Fire trap cover	3030-63	1
22	Washer	X-16312-2	2
23	Nut	X-8040-2	2
24	Door hinge	3030-41	1
25	Spring	3030-38	1
26	Latch	3030-39	1
27	Latch hinge pin	3030-79	1
28	Washer	X-16312-2	16
29	Screw	X-18206-2	16
30	Door	3030-501	1
31	Latch strike	3030-40	1
32	Screw	X-1158-2	8
33	Washer	X-16315-2	8
34	Magazine	3030-504	1
35	Stud	3030-51	2
	Lower base group	3035	1
36	Washer	X-16030-4	4
37	Screw	X-5866-2	2
38	Screw	X-1218-4	4
39	Washer	X-30918-2	2
40	Cover	3030-77	1
41	Bushing	3030-146	2
42	Leveling screw	X-50543	4
43	Nut	X-17364	4
44	Lower base	3030-1	1
45	Connector	3030-84	3
46	Drive screw	X-9973-4	2
47	Name plate	3030-83	1
48	Knurled screw	3030-52	2
49	Cover	3030-505	1
50	Screw	X-5642-2	2
51	Washer	X-16040-2	2
52	Upper base	3030-2	1



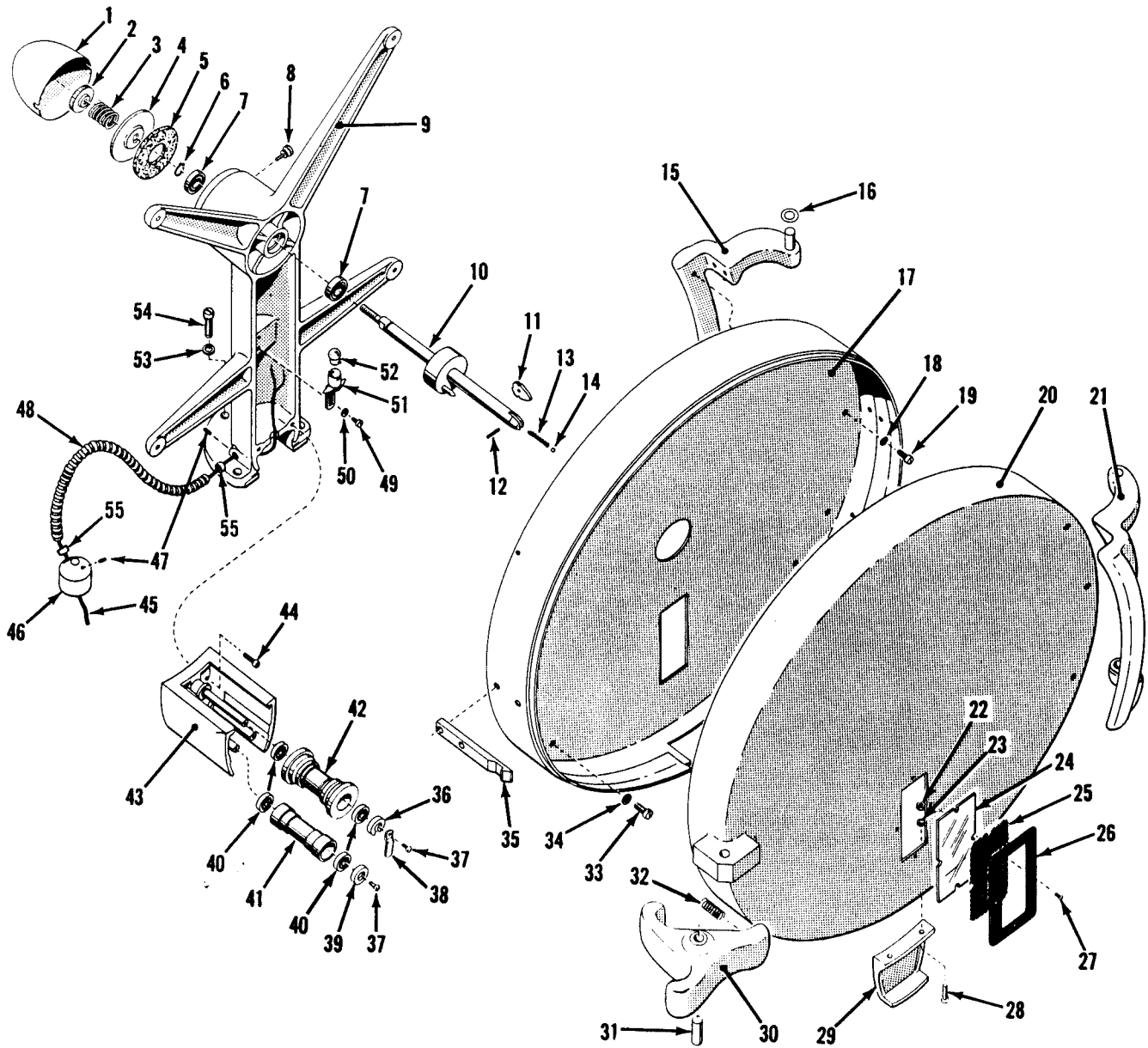

Figure 4. Upper Magazine and Fire Trap No. 3037

Index No.	Description	Part No.	Qty. Req'd.
1	Cap	3030-49	1
2	Friction nut	3030-17	1
3	Friction spring	3030-19	1
4	Pressure disk	3030-15	1
5	Friction disk	3030-16	1
6	Snap ring	X-50473	1
7	Ball bearing	3030-50	2
8	Knurled screw	X-50471-4	2
9	Support	3030-3	1
10	Shaft and driving hub assembly	3030-508	1
11	Reel shaft latch	3030-29	1
12	Roll pin	X-50377	1

UPPER MAGAZINE AND FIRE TRAP NO. 3037 (Cont)

Index No.	Description	Part No.	Qty. Req'd.
13	Latch spring	3030-30	1
14	Ball	35-14	1
15	Magazine hinge	3030-860	1
16	Washer	3030-43	1
17	Magazine	3030-504	1
18	Washer, shakeproof, No. 10, internal tooth	X-16312-2	16
19	Screw, machine, fil hd, No. 10-32 x 3/8	X-18206-2	16
20	Door	3030-502	1
21	Door hinge	3030-41	1
22	Nut, hex, No. 10-32	X-8040-2	2
23	Washer, shakeproof, No. 10, internal tooth	X-16312-2	2
24	Window	3030-44	1
25	Screen	3030-45	1
26	Window frame	3030-46	1
27	Screw, self tapping, bd hd, PK type Z, No. 4 x 1/4	X-9450	4
28	Screw, machine, fil hd, No. 10-32 x 1/2	X-18218-4	2
29	Fire trap cover	3030-63	1
30	Latch	3030-39	1
31	Latch hinge pin	3030-79	1
32	Spring	3030-38	1
33	Screw, machine, fil hd, 1/4-20 x 1/2	X-1158-2	4
34	Washer, shakeproof, No. 1212-00, 1/4 in.	X-16315-2	4
35	Latch strike	3030-40	1
36	Bearing retainer, slotted	3030-60	1
37	Screw, machine, fil hd, No. 8-32 x 5/16	X-972-2	3
38	Strap	3030-62	1
39	Bearing retainer	3030-59	2
40	Ball bearing	3030-11	6
41	Roll (standard) (Roll for 35mm nitrate film)	3030-58 3033-1	2 2
42	Flanged roll (70mm)	3031-1	1
43	Fire trap housing	3030-861	1
44	Cap screw, socket hd, No. 10-32 x 1/2	X-20072-2	2
45	Lamp cord	3030-144	1
46	Cable mount	3030-90	1
47	Setscrew, No. 8-32 x 3/16	X-20703	2
48	Flexible tube	3030-104	1
49	Screw, machine, fil hd, No. 6-32 x 5/16	X-822-2	2
50	Washer, plain, No. 6	X-16010-2	2
51	Lamp socket	11300-23	1
52	Lamp, upper magazine	3030-159	1
53	Lockwasher, 5/16 spring	X-16222-4	3
54	Cap screw, hex hd, 5/16-18 x 1 1/4	X-5462-4	3
55	Insulating bushing	3030-122	2

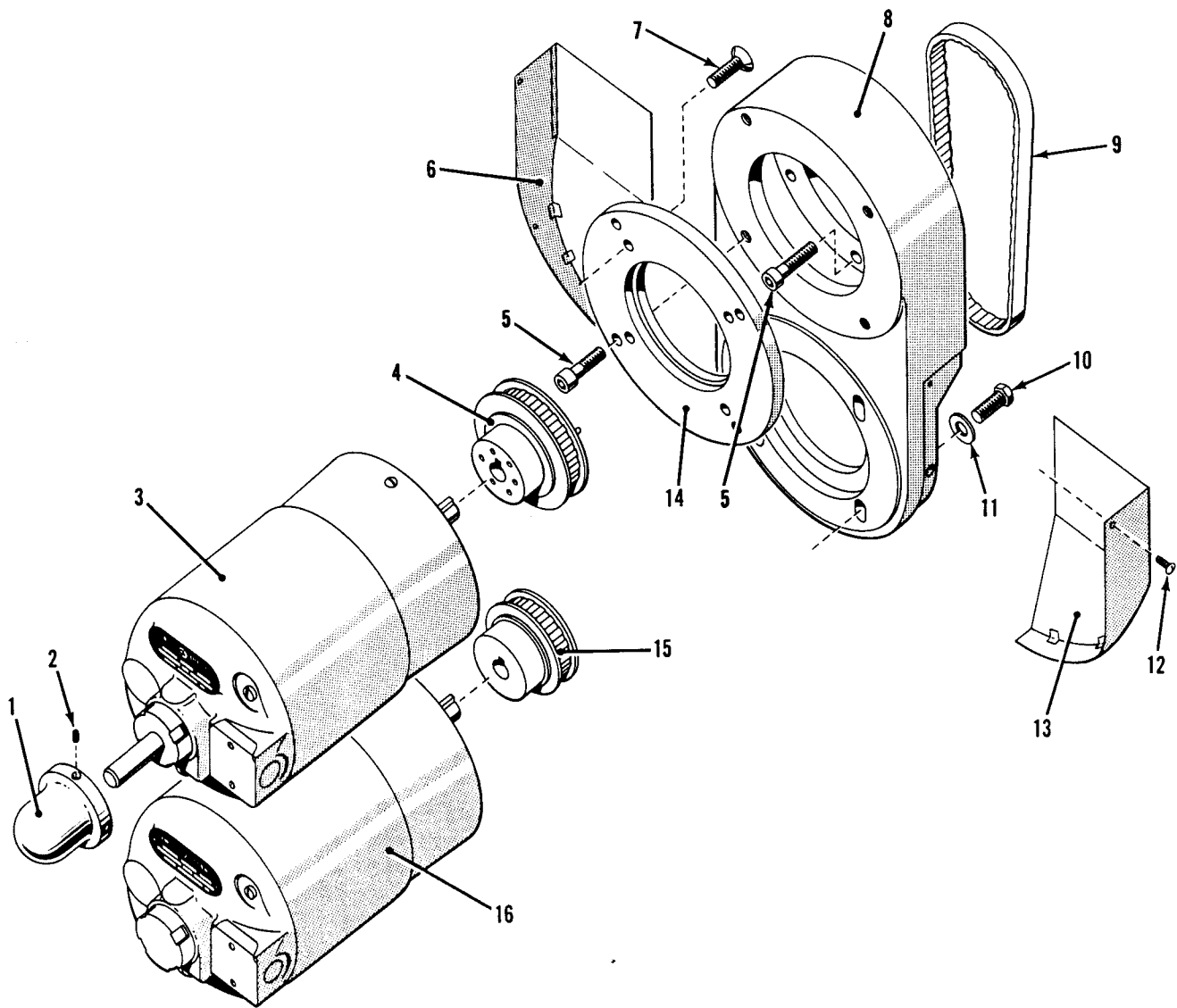

Figure 5. Motor Drive Assembly.

Index No.	Description	Part No.	Qty. Req'd.
1	Inching knob	3062-7	1
2	Setscrew, No. 10-32 x 3/8	X-21048	2
3	Motor, double shaft	3063-1	1
4	Upper drive pulley	3062-501	1
5	Cap screw, socket head 3/8-16 x 1 1/4	X-19742	8
6	Right-hand cover	3062-504	1
7	Screw, 3/8-16 x 3/4	X-34644	4
8	Drive housing	3062-1	1
9	Belt	3065-1	1
10	Cap screw, hex head, 3/8-16 x 1	X-5558	4
11	Washer, 3/8 standard	X-30913	4
12	Machine screw, No. 8-32 x 1/4	X-296	4
13	Left-hand cover	3062-503	1
14	Adapter plate	3062-3	1
15	Lower drive pulley	3062-6	1
16	Motor, single shaft	3064-1	1

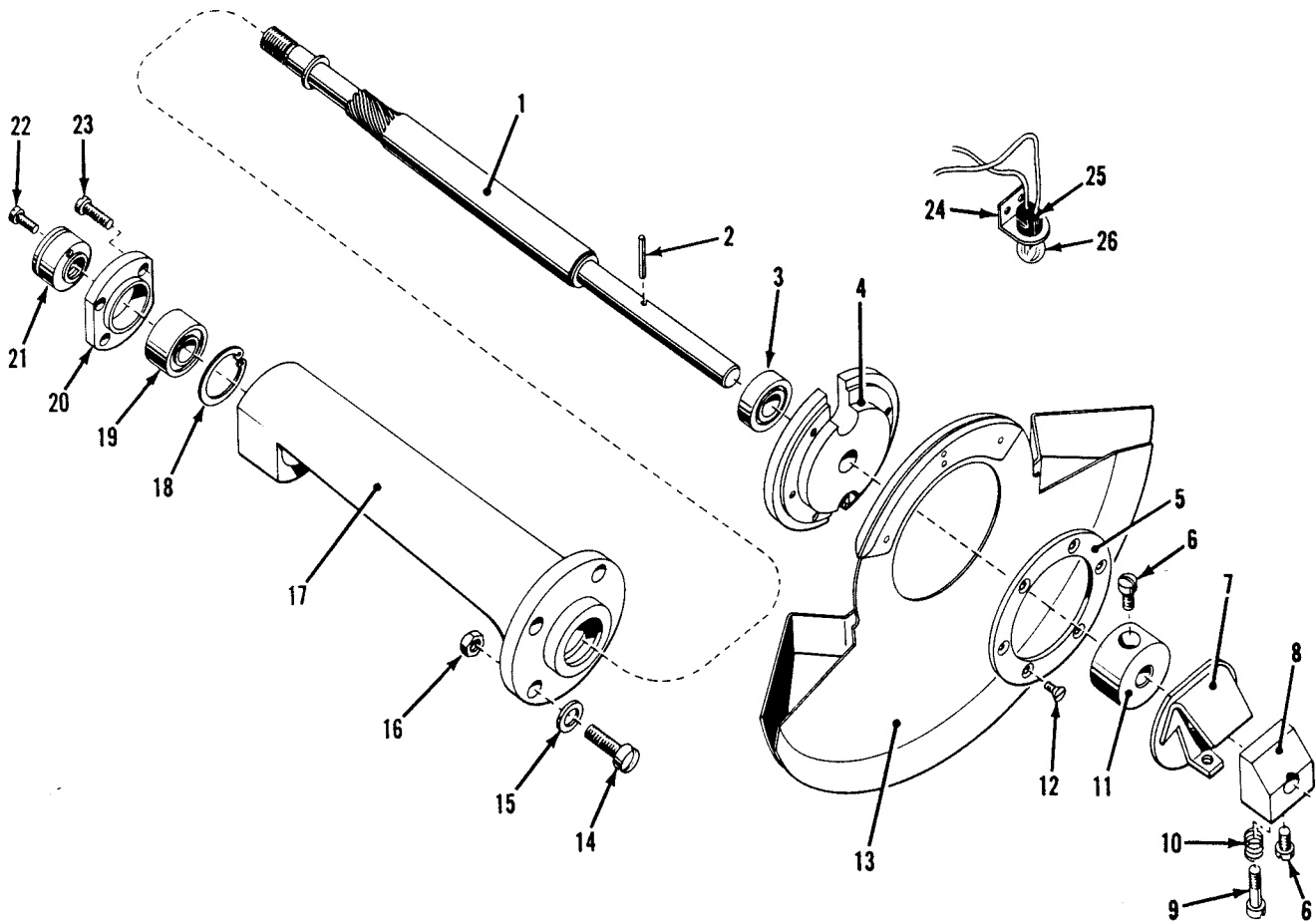

Figure 6. Shutter Shaft Assembly.

Index No.	Description	Part No.	Qty. Req'd.
	Shutter shaft and bearing assembly	C1 705 53	1
1	Shutter shaft		1
2	Fluted pin		1
3	Ball bearing		1
4	Shutter blade mount		1
5	Pressure ring	C1 750 18	1
6	Screw	X-18206-2	2
	Guard and block assembly	C1 705 54	1
7	Guard assembly	C1 751 29	1
8	Block	C1 751 32	1
	Screw (6)	X-18206-2	2
9	Screw	C1 751 30	1
10	Spring	C1 751 34	1
11	Collar	C1 751 33	1
12	Screw	X-1625-2	1
13	Shutter	C1 750 31	1
14	Screw	X-1170-2	4
15	Washer	X-16025-2	4
16	Nut	X-8025-2	4
17	Shutter shaft bracket	C1 750 22	1
18	Retaining ring	07 892 30	1
19	Ball bearing	89 183 50	1
20	Thrust ring	C1 751 31	1
21	Locknut	C1 750 20	1
22	Screw	X-990-2	1
23	Screw	X-996-2	4
24	Framing lamp bracket	C1 050 77	1
25	Framing lamp socket	E2 894 62	1
26	Framing lamp	3030-159	1

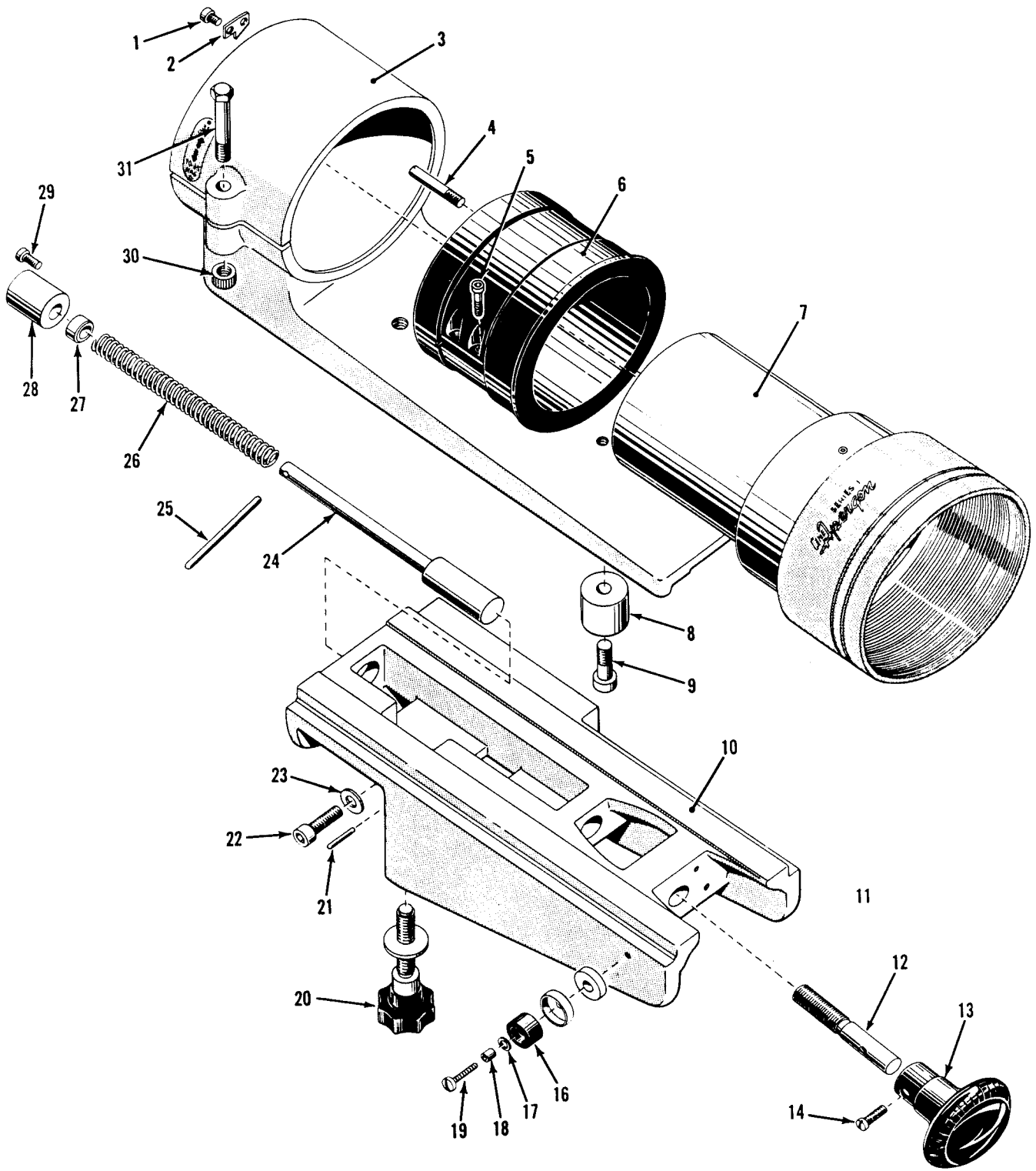

Figure 7. Lens Bracket Assembly.

LENS BRACKET ASSEMBLY

Index No.	Description	Part No.	Qty. Req'd.
1	Cap screw, hol hd, No. 10-24 x 3/8 in.	X-19448-2	4
2	Stop	3090-2	2
3	Lens mount	3030-862	1
4	Eccentric adjusting pin	0856	1
5	Eccentric clamping screw	X-19466	2
6	Eccentric assembly with flange (Includes Index Nos. 4 and 5)	3141	1
(Not shown)	Eccentric assembly without flange (For 3248 objective only) (Includes Index Nos. 4 and 5)	3142	1
(Not shown)	Eccentric assembly without flange (For 3256 objective only) (Includes Index Nos. 4 and 5)	3145	1
7	E.F.L. projection objective (2.6) (3.0) (3.5) (4.1) (4.8) (5.6) (6.6)	CAT. NOS. 3226 3230 3235 3241 3248 3256 3266	
8	Stop	3090-4	1
9	Cap screw, hol hd, 3/8-16 x 1 1/4	X-19742	1
10	Lens mount bracket	C1 605 43	1
11	Bushing		1
12	Focusing screw	C1 902 04	1
13	Knob	23 705 04	1
14	Screw, machine, fil hd, No. 10-32 x 5/8	X-18224	1
15	Cup	C1 902 08	1
16	Rubber bumper	25 985 17.1	1
17	Washer	07 029 48	1
18	Bushing	V3 080 07	1
19	Screw	B 080 AF/8N-32 x 1 1/2"	1
20	Knob assembly	C1 605 84	1
21	Dowel pin	B 042 AA/5X16	2
22	Cap screw, hol hd, 5/16-18 x 1 in.	X-19646	4
23	Washer	X-16030	4
24	Spring plunger	C1 605 67	1
25	Pin	C1 605 65	1
26	Spring	C1 605 66	1
27	Ring	C1 605 80	1
28	Flange	C1 605 38	1
29	Screw, machine, fil hd, No. 8-32 x 3/8	X-978	3
30	Allenut	X-50516	1
31	Screw	X-50517	1
32	Spacer	-----	1

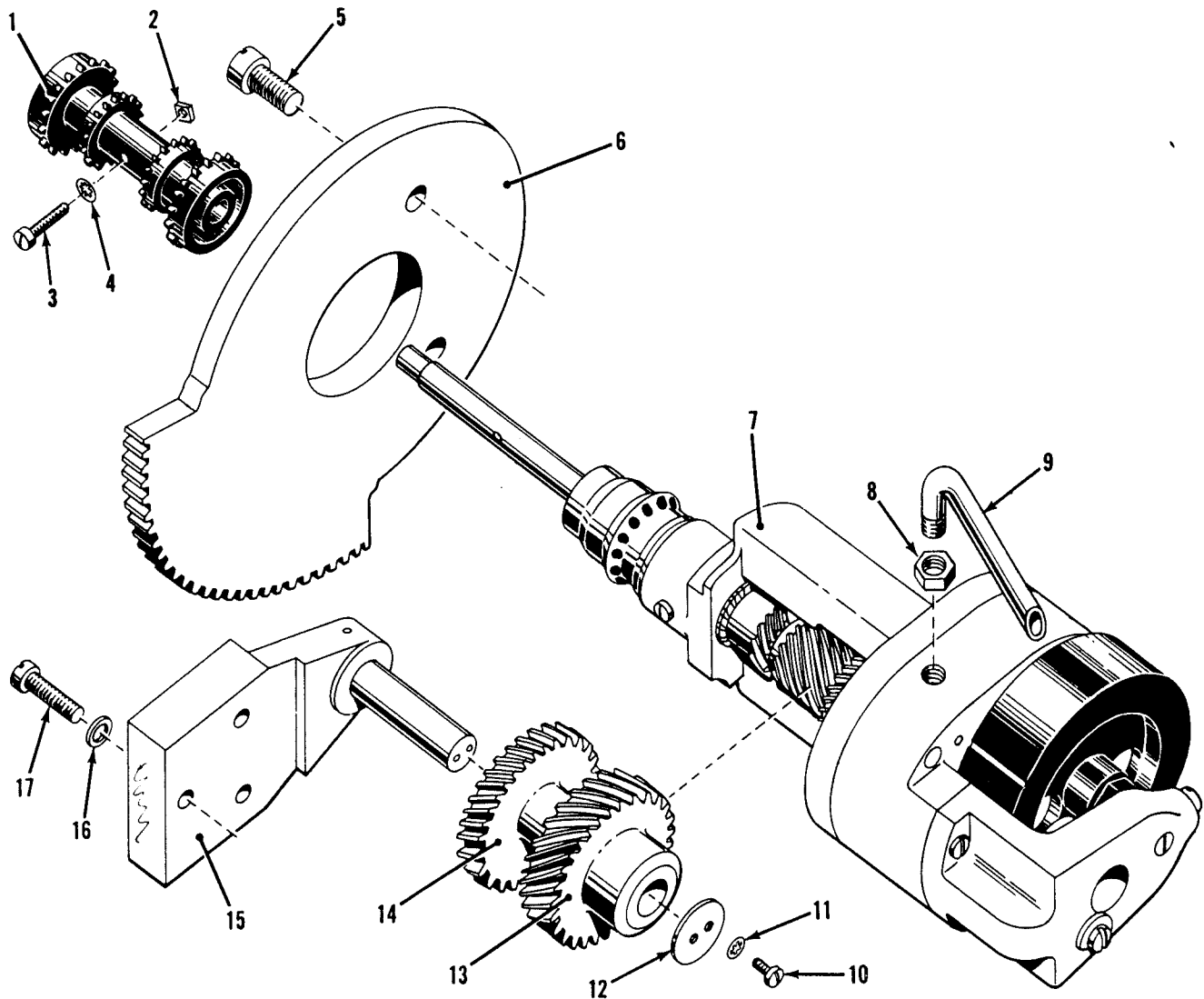

Figure 8. Intermittent Mechanism.

Index No.	Description	Part No.	Qty. Req'd.
	Intermittent sprocket (1) including screw (3), washer (4), and nut (2)	C1 705 92	1
1	Intermittent sprocket	C1 703 36	1
2	Nut	C1 751 23	1
3	Screw	C1 751 02	1
4	Washer	07 045 22	1
5	Screw	C1 704 83	2
6	Framing gear segment	C1 050 15	1
7	Intermittent assembly less sprocket (1), screw (3), washer (4), and nut (2)	C1 705 49	1
8	Nut	C1 705 16	1
9	Oil pipe	C1 705 15	1
10	Screw	X-798-2	2
11	Washer	X-16303	2
12	Retaining washer	C1 750 14	1
13	Drive idler	C1 750 11	1
14	Framing idler	C1 750 12	1
15	Idler shaft and bracket assembly	C1 750 15	1
16	Gasket	C1 750 17	3
17	Screw	X-1170-2	3

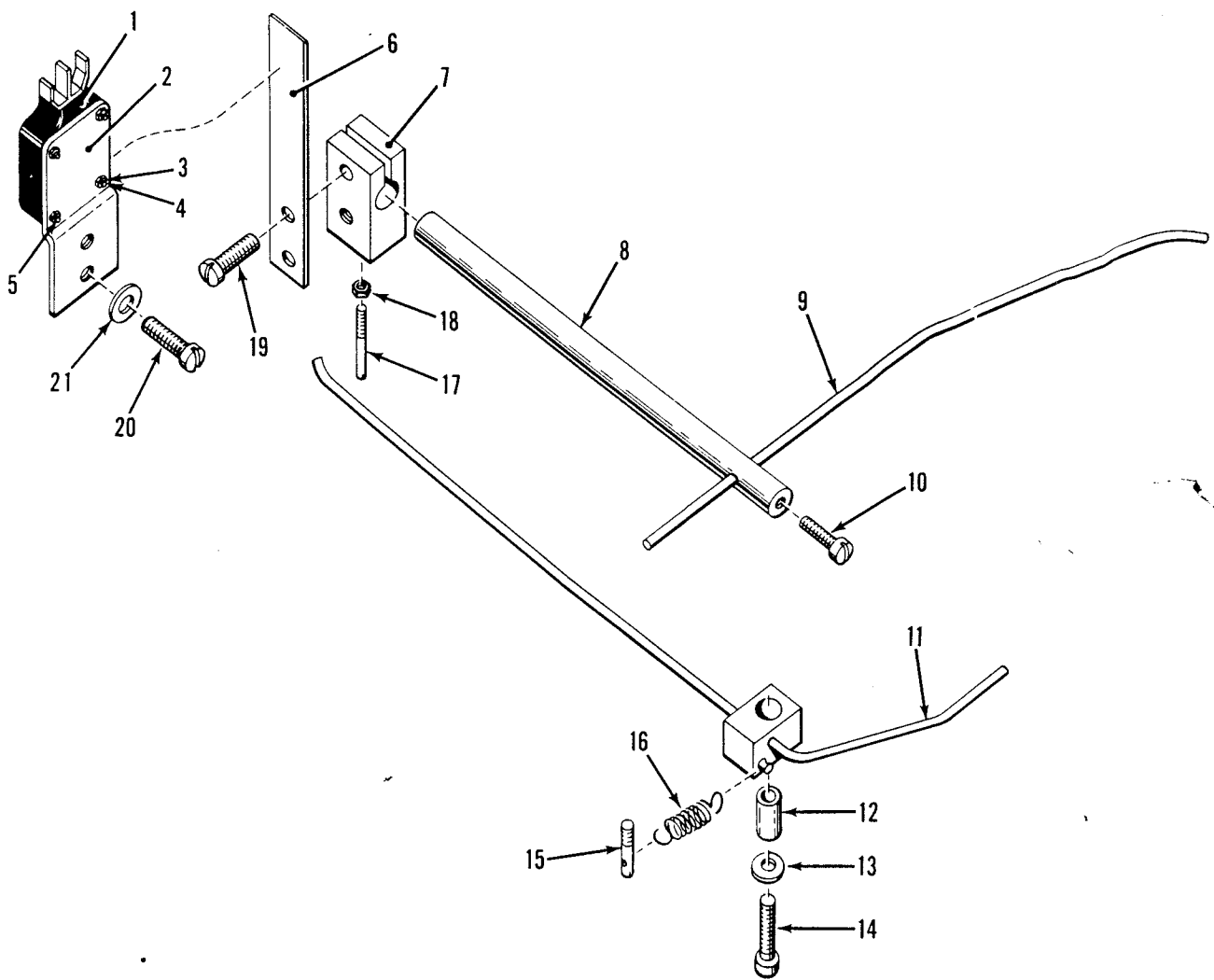

Figure 9. Film Buckle Switch and Levers.

Index No.	Description	Part No.	Qty. Req'd.
1	Microswitch	C1 106 80	1
2	Microswitch bracket	C1 050 65	1
3	Nut	X-8000-2	1
4	Washer	X-16000-2	1
5	Screw	X-756-2	1
6	Actuating lever	C1 050 66	1
7	Block	C1 050 68	1
8	Pivot shaft	C1 050 64	1
9	Film buckle arm	C1 050 60	1
10	Screw	X-990-4	1
11	Lever arm	C1 704 05	1
12	Bushing	07 005 46	1
13	Washer	X-16015-2	1
14	Screw	X-1002-2	1
15	Spring holder	C1 704 02	1
16	Spring	C1 704 01	1
17	Operating stud	C1 704 28	1
18	Nut	X-8005-2	1
19	Screw	X-990-2	2
20	Microswitch mounting screw	X-996-4	2
21	Washer	X-16015-4	2



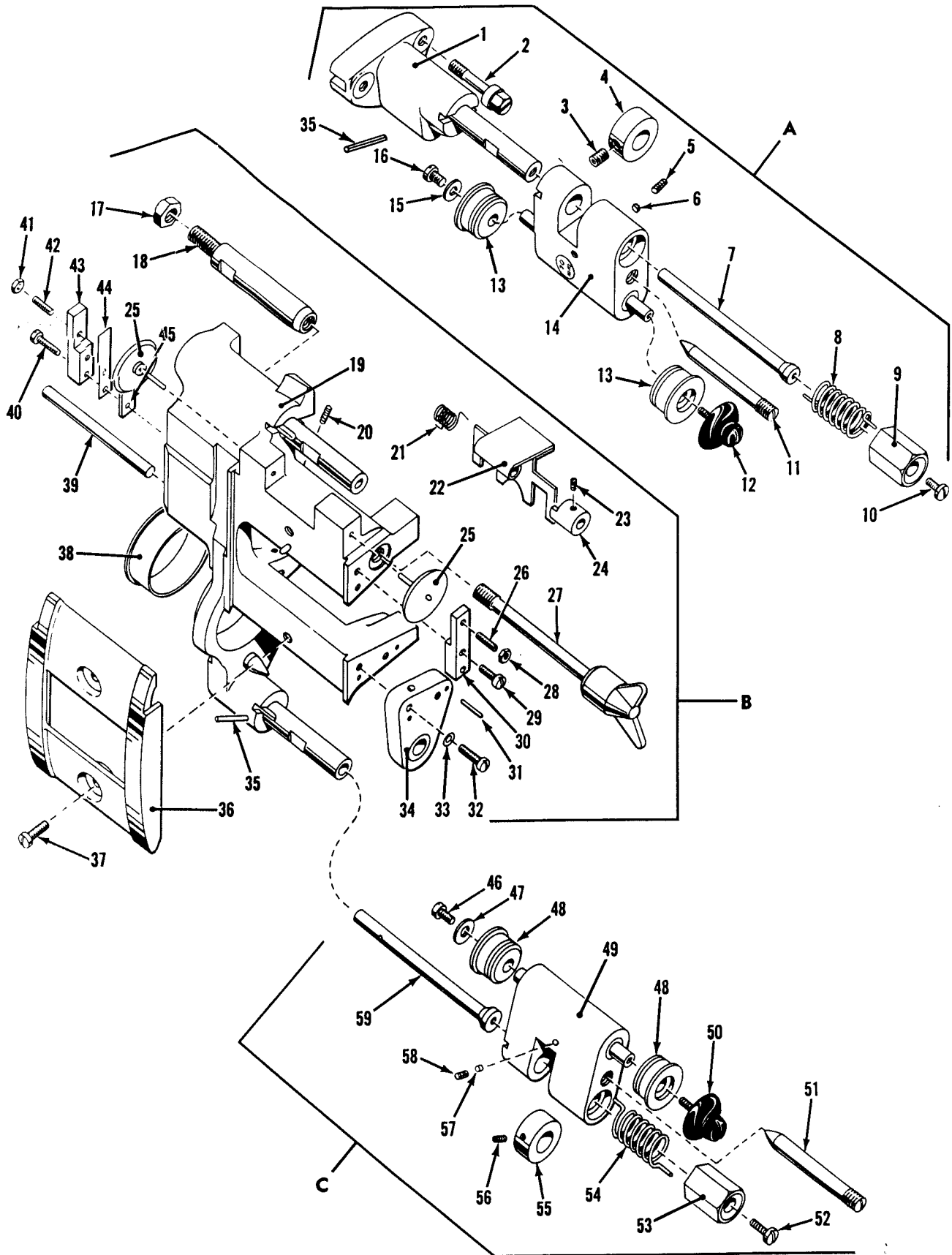

Figure 10. 70mm Film Gate and Pad Rollers.

## 70MM FILM GATE AND PAD ROLLERS

Index No.	Description	Part No.	Qty. Req'd.
A. 70mm Pad Roller Assembly (Upper and Lower)			
	70mm pad roller assembly (1 through 16)	C1 606 13	2
1	Bracket assembly	C1 606 10	2
2	Captive screw	C1 704 72	4
3	Setscrew	X-21039	2
4	Adjusting collar	C1 703 93	2
5	Setscrew	X-30091	2
6	Leather plug	C1 606 87	2
7	Pin	C1 606 12	2
8	Torsion spring, right-hand	C1 605 74	2
9	Adjusting nut	C1 605 71	2
10	Locking screw	X-978-4	2
11	Adjusting pin	C1 605 72	2
12	Cap	C1 605 75	2
13	Roller	P5 635 21	4
14	Arm and shaft assembly	C1 607 17	2
15	Washer	X-16015-2	2
16	Screw	X-966-2	2
B. 70mm Film Gate			
	70mm Film gate assembly (17 through 59)	C1 606 15	
17	Nut	X-8030-2	1
18	Shoulder stud	C1 606 90	1
19	Film gate bracket	C1 705 58	1
20	Setscrew	X-20706	1
21	Torsion spring	C1 605 89	1
22	Film stripper	C1 605 87	1
23	Setscrew	X-20703	1
24	Adjusting collar	C1 605 88	1
25	Guide roller assembly	C1 605 46	2
26	Adjusting screw	C1 605 52	1
27	Captive screw	C1 605 53	1
28	Nut	X-8015-4	2
29	Screw	X-3618-4	2
30	Block	C1 605 51	1
31	Dowel pin	07 911 12	1
32	Screw	X-3642-4	2
33	Washer	X-16015-4	2
34	Outboard bearing	C1 605 57	1
35	Roll pin	07 539 36	2
36	Runner plate	C1 606 93	1
37	Screw	X-33665-4	1
38	Nylon protecting ring	P5 635 37	1
39	Stripper shaft	C1 605 90	1
40	Screw	X-3630-4	2
41	Nut	X-8015-4	2
42	Adjusting screw	X-30096	1
43	Block	C1 605 50	1
44	Leaf spring	C1 605 48	1
45	Strip	C1 605 49	1
C. 70mm Film Gate Pad Roller Assembly (Lower)			
NOTE: The upper film gate pad roller is not shown. The two film gate pad rollers are identical except that the upper film gate pad roller uses a left-hand torsion spring and the lower film gate pad roller uses a right-hand torsion spring.			
46	Screw	X-966-2	2
47	Washer	X-16015-2	2
48	Roller	P5 635 21	4
49	Arm and shaft assembly	C1 607 17	2

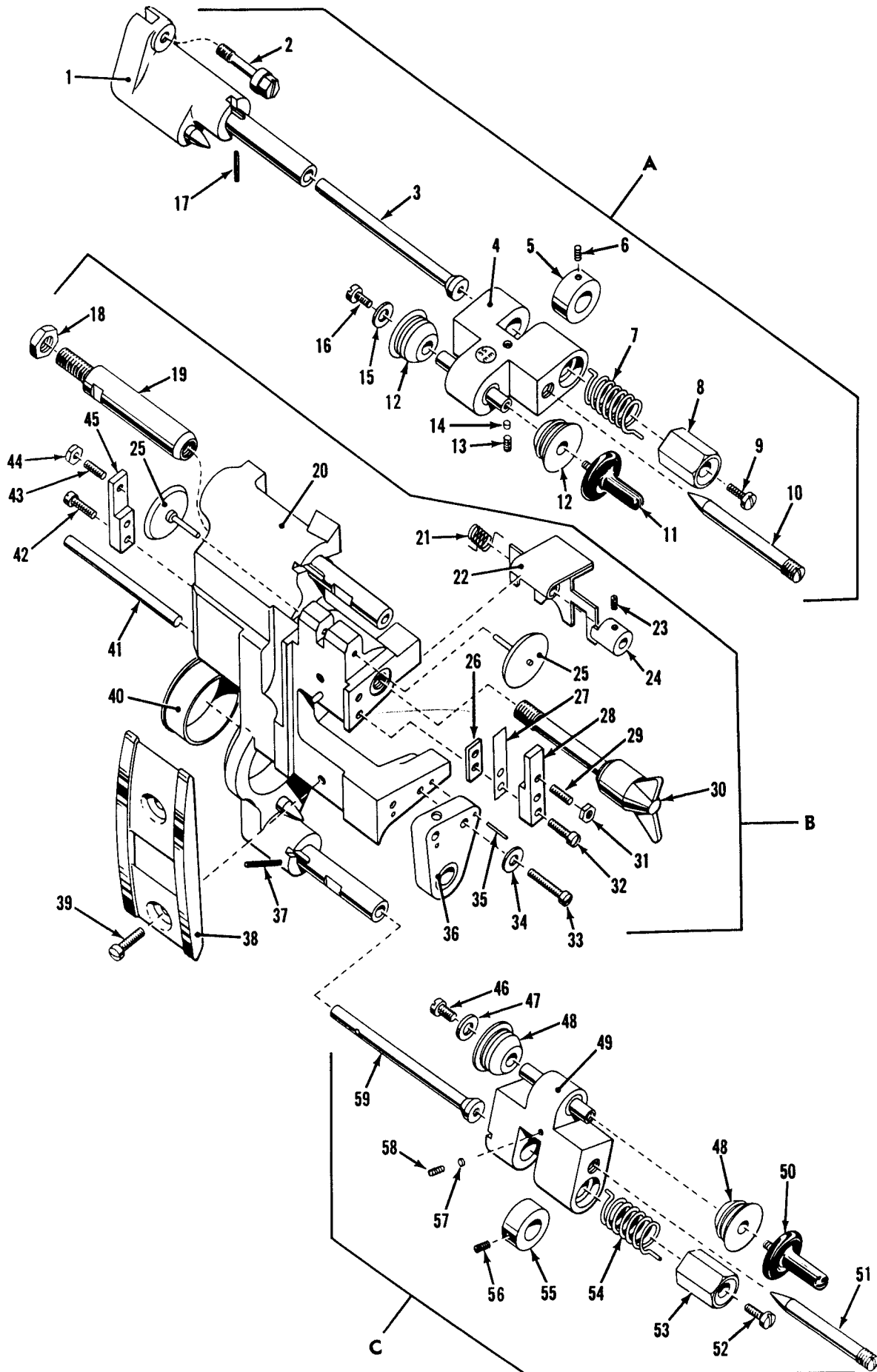

Figure 11. 35mm Film Gate and Pad Rollers.

70MM FILM GATE AND PAD ROLLERS (Cont)

Index No.	Description	Part No.	Qty. Req'd.
50	Cap	C1 605 75	2
51	Adjusting pin	C1 605 72	2
52	Screw	X-3618-4	2
53	Torsion spring adjusting nut	C1 605 71	2
54	Torsion spring, right-hand	C1 605 74	1
	Torsion spring, left-hand	C1 606 16	1
	(for upper film gate pad roller) (not shown)		
55	Adjusting collar	C1 703 93	2
56	Setscrew	X-21039	4
57	Leather plug	C1 606 87	2
58	Setscrew	X-30091	2
59	Pin	C1 606 12	2

35MM FILM GATE AND PAD ROLLERS

Index No.	Description	Part No.	Qty. Req'd.
	A. 35mm Pad Roller Assembly (Upper and Lower)		
	35mm pad roller assembly (1 through 17)	C1 606 29	2
1	Bracket assembly	C1 606 10	2
2	Captive screw	C1 704 72	4
3	Pin	C1 606 12	2
4	Arm and shaft assembly	C1 607 18	2
5	Adjusting collar	C1 703 93	2
6	Setscrew	X-21039	2
7	Torsion spring, right-hand	C1 605 74	1
	Torsion spring, left-hand	C1 606 16	1
	(for upper film gate pad roller)		
8	Adjusting nut	C1 605 71	2
9	Locking screw	X-978-4	2
10	Adjusting pin	C1 605 72	2
11	Cap	C1 606 28	2
12	Roller	P5 635 22	4
13	Setscrew	X-30091	2
14	Leather plug	C1 606 87	2
15	Washer	X-16015-2	2
16	Screw	X-966-2	2
17	Roll pin	B 074 AF/2X20	2
	B. 35mm Film Gate		
	35mm film gate assembly (18 through 59) C1 606 34		
18	Nut	X-8030-2	1
19	Shoulder stud	C1 606 90	1
20	Film gate bracket	C1 705 59	1
21	Torsion spring	C1 605 89	1
22	Film stripper	C1 605 87	1
23	Setscrew	X-20703	1
24	Collar	C1 605 88	1
25	Guide roller assembly	C1 605 46	2
26	Strip	C1 605 49	1
27	Leaf spring	C1 605 48	1
28	Block	C1 605 50	1
29	Adjusting screw	X-30096	1
30	Captive screw	C1 606 33	1

35MM FILM GATE AND PAD ROLLERS (Cont)

Index No.	Description	Part No.	Qty. Req'd.
31	Nut	X-8015-4	2
32	Screw	X-3630-4	2
33	Screw	X-3642-4	2
34	Washer	X-16015-4	2
35	Dowel pin	07 911 12	2
36	Outboard bearing	C1 605 57	1
37	Roll pin	07 593 36	2
38	Runner plate	C1 606 95	1
39	Screw	X-18218-4	2
40	Nylon protecting ring	P5 635 37	1
41	Stripper shaft	C1 605 90	1
42	Screw	X-978-4	2
43	Adjusting screw	C1 605 52	1
44	Nut	X-8015-4	2
45	Block	C1 605 51	1
C. Lower Film Gate Pad Roller Assembly			
NOTE: The upper film gate pad roller is not shown. The two film gate pad rollers are identical except that the upper film gate pad roller uses a left-hand torsion spring and the lower film gate pad roller uses a right-hand torsion spring.			
46	Screw	X-966-2	2
47	Washer	X-16015-2	2
48	Roller	P5 635 22	4
49	Arm and shaft assembly	C1 607 18	2
50	Cap	C1 606 28	2
51	Adjusting pin	C1 605 72	2
52	Screw	X-978-4	2
53	Torsion spring adjusting nut	C1 605 71	2
54	Torsion spring, right-hand	C1 605 74	1
	Torsion spring, left-hand (for upper film gate pad roller)(not shown)	C1 606 16	1
55	Adjusting collar	C1 703 93	2
56	Setscrew	X-21039	2
57	Leather plug	C1 606 87	2
58	Setscrew	X-30091	2
59	Pin	C1 606 12	2

COOLING PLATE C1 606 17\*

Index No.	Description	Part No.	Qty. Req'd.
1	Locking pin	C1 704 21	1
2	Roll pin	07 593 32	1
3	Spring	C1 704 23	1
4	Nut	C1 704 58	5
5	Washer	X-16015-2	1
6	Spring washer	0 1068	4
7	Locking pin holder	C1 704 20	1
8	Nut	X-8005-2	1
9	Washer	X-16303-2	1
10	Screw	X-3612-2	8
11	Washer	X-16309-2	11
12	Pin	07 911 08	4
13	Aperture clip	C1 704 60	1

COOLING PLATE C1 606 17 (Cont)

Index No.	Description	Part No.	Qty. Req'd.
14	Upper pressure band holder	C1 704 24	1
15	Pressure bands (70mm)	CAT. 3016	1 pr.
16	Pressure bands (35mm)	NOS. 3017	1 pr.
17	Aperture plate (70mm)	C1 704 70	1
18	Screw	X-1618-2	1
19	Locating pin	C1 704 61	1
20	Lower pressure band holder assembly	C1 705 60	1
21	Latch	C1 704 59	1
22	Shoulder screw	C1 704 57	1
23	Spring washer	07 043 07	1
24	Spacer	C1 607 68	1
25	Snap ring	B 048 AG/1.9	1
26	Knurled nut	C1 605 99	1
27	Threaded pin	C1 605 98	1
28	Centering pin	C1 704 62	1
29	Locking pin knob	C1 704 22	1
30	Screw	X-3612-4	3
31	Cooling plate	C1 605 37	1
32	Hose clamp	X-50519	2
33	Flexible hose	C1 704 74	2

\* This number does not include: Hose (33), Hose clamps (32), 35mm Pressure bands (16).

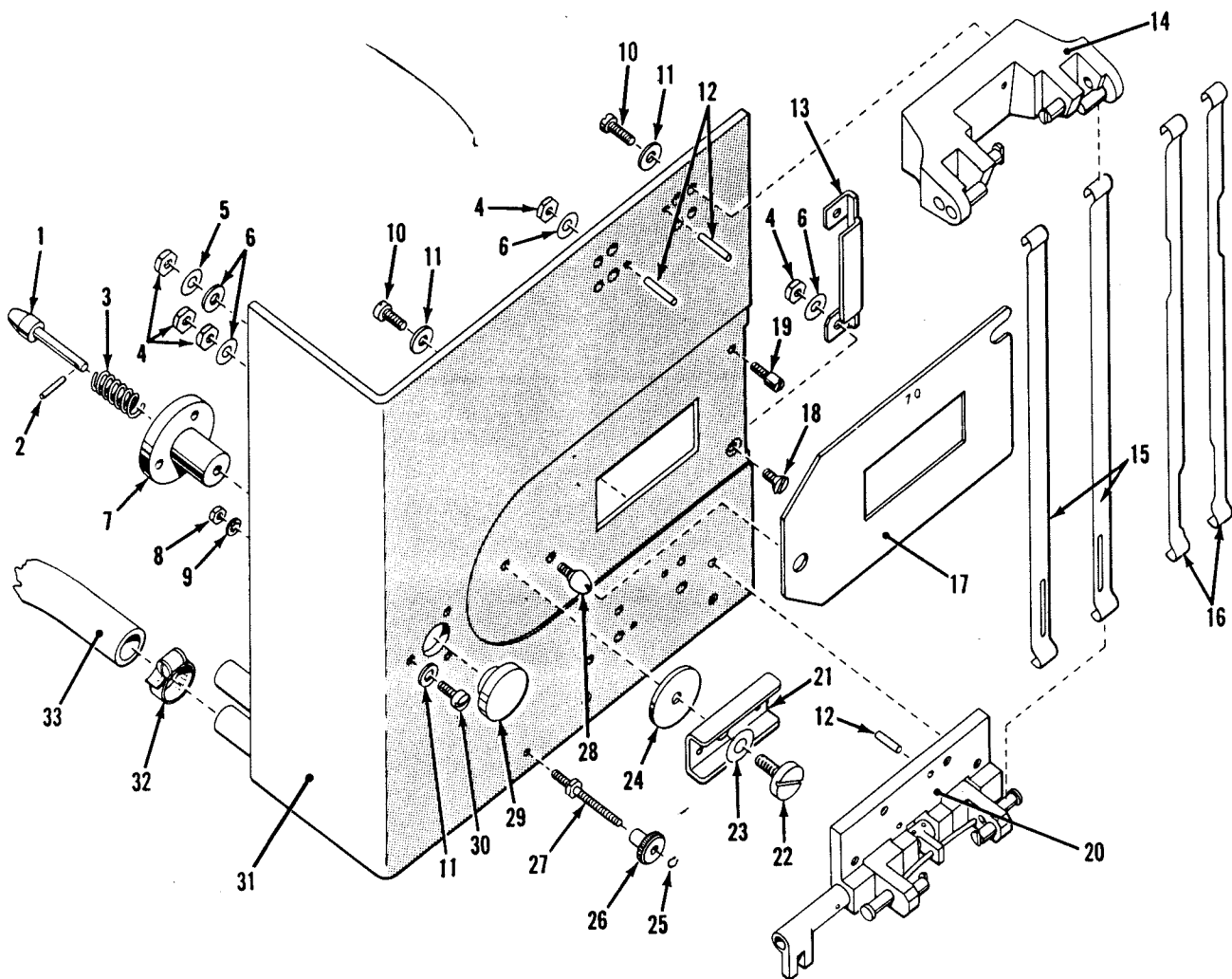

Figure 12. Cooling Plate C1 606 17.

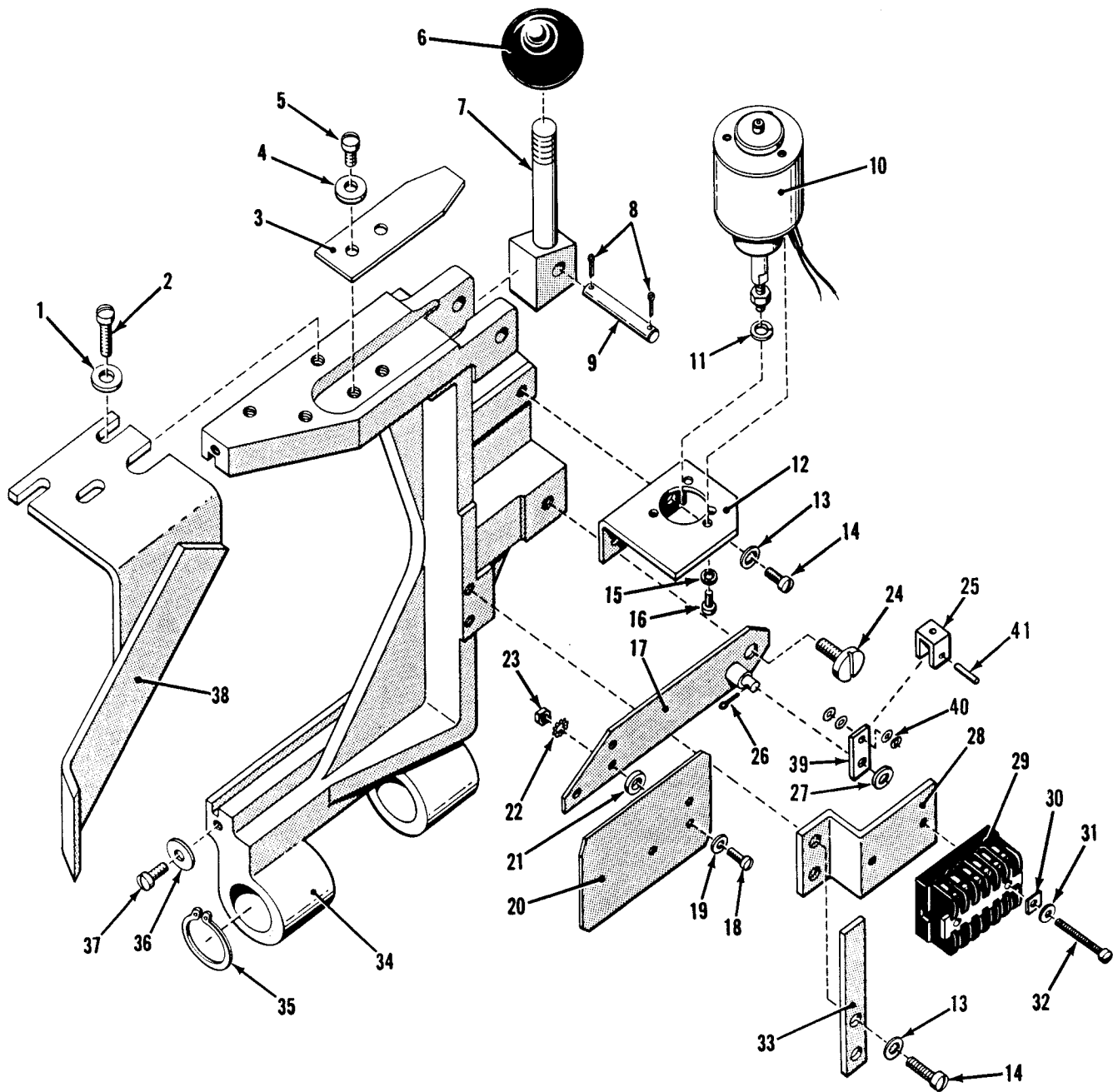

Figure 13. Cooling Plate Holder Assembly C1 703 65.

COOLING PLATE HOLDER ASSEMBLY C1 703 65  
(Part 35 not included.)

Index No.	Description	Part No.	Qty. Req'd.
1	Washer	X-16020-2	3
2	Screw	X-18224-2	3
3	Leaf spring	C1 703 60	1
4	Washer	X-16020-2	2
5	Screw	X-18206-2	2
6	Knob	23 575 10	1
7	Lever assembly	C1 703 61	1
8	Cotter pin	X-24018	2
9	Pin	C1 704 18	1
10	Dowser solenoid	C1 902 09	1
11	Washer	X-16309-2	1
12	Bracket	C1 902 14	1
13	Lockwasher, internal tooth	X-16309	4
14	Screw	X-978-2	2
15	Washer	07 045 22	3
16	Screw	07 803 08	3
	Dowser arm assembly	C1 902 11	1
17	Dowser arm		
18	Screw		
19	Washer		
20	Dowser		
21	Spacer		
22	Lockwasher		
23	Nut		
24	Screw	C1 703 56	1
25	Yoke	C1 902 10	1
26	Cotter pin	X-24000	1
27	Washer	X-16015-2	1
28	Bracket	C1 703 57	1
29	Terminal block	B1 880 86	1
30	Clip	V3 162 47	2
31	Washer	X-16303	2
32	Screw	X-840-2	2
33	Strip	C1 704 15	1
34	Holder	C1 703 44	1
*35	Snap ring	B 045 BF/20	1
36	Washer	07 025 01	2
37	Screw	X-972-2	2
38	Arm, safety	C1 606 66	1
39	Link	C1 902 15	1
40	Washer	B 050 CN/2	4
41	Roll pin	B 074 AF/2X8	1

\* Not included in Cooling Plate  
Holder Assembly.C1 703 65



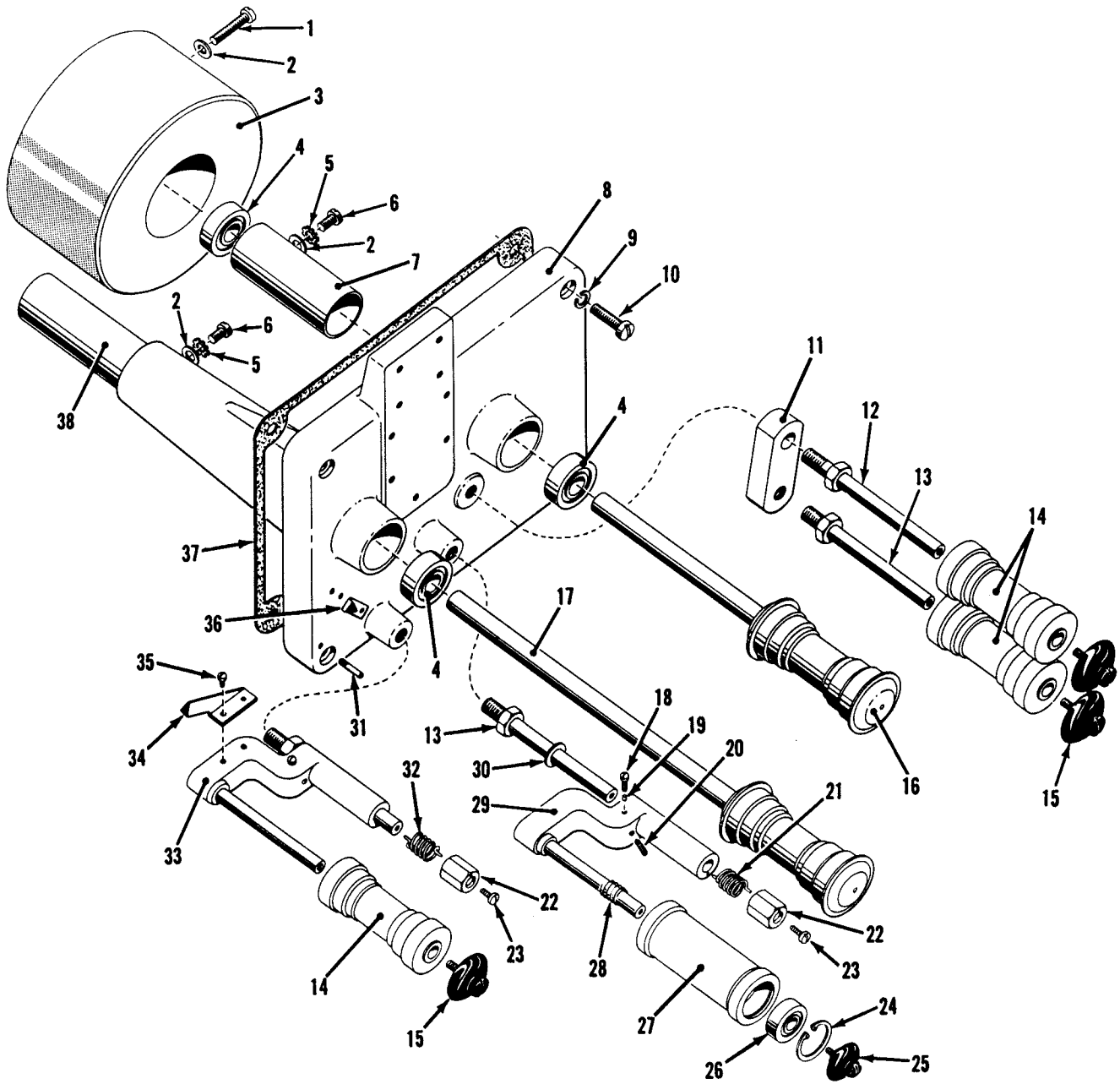

Figure 14. Magnetic Soundhead Cat. No. 3020.

## MAGNETIC SOUNDHEAD CAT. NO. 3020

Index No.	Description	Part No.	Qty. Req'd.
1	Screw	X-18242-2	2
2	Washer	X-16020-2	4
3	Stabilizer	C1 407 54	2
4	Ball bearing	C1 407 85	4
5	Lockwasher	X-16334	2
6	Screw	X-18200-2	2
7	Bearing spacer, short	C1 407 51	1
8	Mounting plate	C1 407 57	1
*9	Washer	B 050 AE/6	4
*10	Screw	X-19538-4	4
11	Arm	C1 407 50	1
12	Pivot stud	C1 407 49	1
13	Stud for roller	C1 407 48	3
14	Roller	P5 635 26	3
15	Cap	C1 407 79	3
16	Stabilizer shaft, short	C1 407 11	1
17	Stabilizer shaft, long	C1 407 13	1
18	Screw	X-3426-4	2
19	Plug	C1 407 88	2
20	Adjusting screw	C1 407 09	2
21	Spring	22 413 24	1
22	Adjusting nut	C1 407 87	2
23	Locking screw	X-978-4	2
24	Snap ring	07 892 22	2
25	Cap	C1 407 05	1
26	Ball bearing	C1 607 31	2
27	Pressure roller	P5 635 24	1
28	Spring	C1 407 06	1
29	Arm assembly for pressure roller	C1 704 89	1
30	Washer	22 414 99	2
31	Stop pin	C1 704 47	1
32	Spring	22 413 25	1
33	Arm assembly for guide roller	C1 407 04	1
34	Pointer (moving)	C1 407 55	1
35	Screw	X-3426-4	4
36	Pointer (fixed)	C1 407 56	1
37	Gasket	C1 407 53	1
38	Bearing spacer, long	C1 407 52	1

\* These parts not included with the magnetic soundhead Cat. No. 3020.

## OPTICAL SOUNDHEAD CAT. NO. 3055

Index No.	Description	Part No.	Qty. Req'd.
1	Knurled nut	C1 408 07	1
2	Washer	B 050 CE/5	1
3	Photocell	3052-1	1
4	Photocell socket	40218/03	1
5	Screw	X-990-2	3
6	Lockwasher	X-16333-2	3
7	Photocell bracket	C1 406 85	1
8	Snap ring	B 045 AF/32	3
9	Photocell cover	C1 406 86	1
10	Ball bearing	89 225 16	2
11	Stabilizer	22 439 38	1
12	Spacer	22 439 37	1
13	Exciter light cable	C1 406 87	1
14	Screw	X-786-2	4
15	Cable clip	X-34327	4
16	Washer	22 414 99	1
	Pressure roller and arm assembly	C1 406 88	1
17	Leather plug	C1 407 88	1
18	Screw	X-972-2	1
19	Arm assembly	C1 406 90	1
20	Adjusting screw	C1 407 82	1
21	Setscrew	X-20592	1
22	Thrust collar	C1 407 81	1

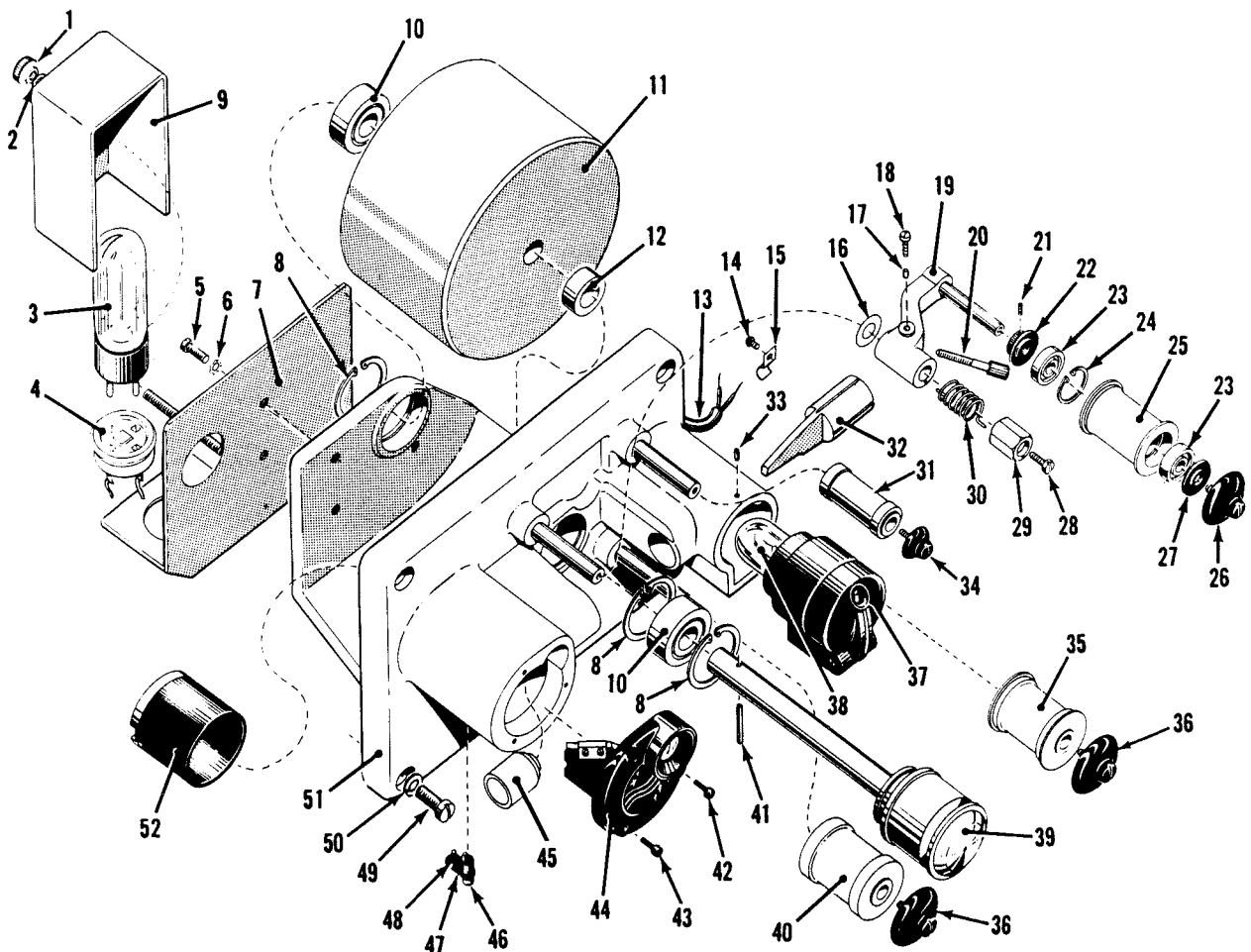

Figure 15. Optical Soundhead Cat. No. 3055

OPTICAL SOUNDHEAD CAT. NO. 3055 (\* Parts 49,50 not included.)

Index No.	Description	Part No.	Qty. Req'd.
23	Ball bearing	8Q 180 99	2
24	Snap ring	07 892 19	2
25	Pressure roller	22 443 11	1
26	Cap	C1 407 79	1
27	Thrust washer	22 439 43	1
28	Locking screw	X-798-4	1
29	Adjusting nut	C1 407 87	1
30	Spring	22 413 24	1
31	Roller	22 439 07	1
32	Condensing lens	C1 407 94	1
33	Setscrew	X-25103	4
34	Cap	C1 407 84	1
35	Guide roller	22 265 95	1
36	Cap	C1 407 79	2
37	Exciter light holder assembly	C1 407 75	1
38	Exciter light	3053-1	1
39	Drum	22 439 26	1
40	Guide roller	22 449 80	1
41	Roll pin	X-50542	1
42	Screw	X-798-4	2
43	Special screw	C1 407 76	1
44	Cover and mirror assembly	22 439 16	1
45	Objective assembly	22 439 32	1
46	Eccentric pin	22 439 23	2
47	Locking plate	22 439 24	2
48	Locking screw	X-798-2	2
* 49	Screw	X-19538-4	4
* 50	Washer	B 050 AE/6	4
51	Mounting plate	C1-406-84	1
52	Slit holder assembly	C1 407 91	1

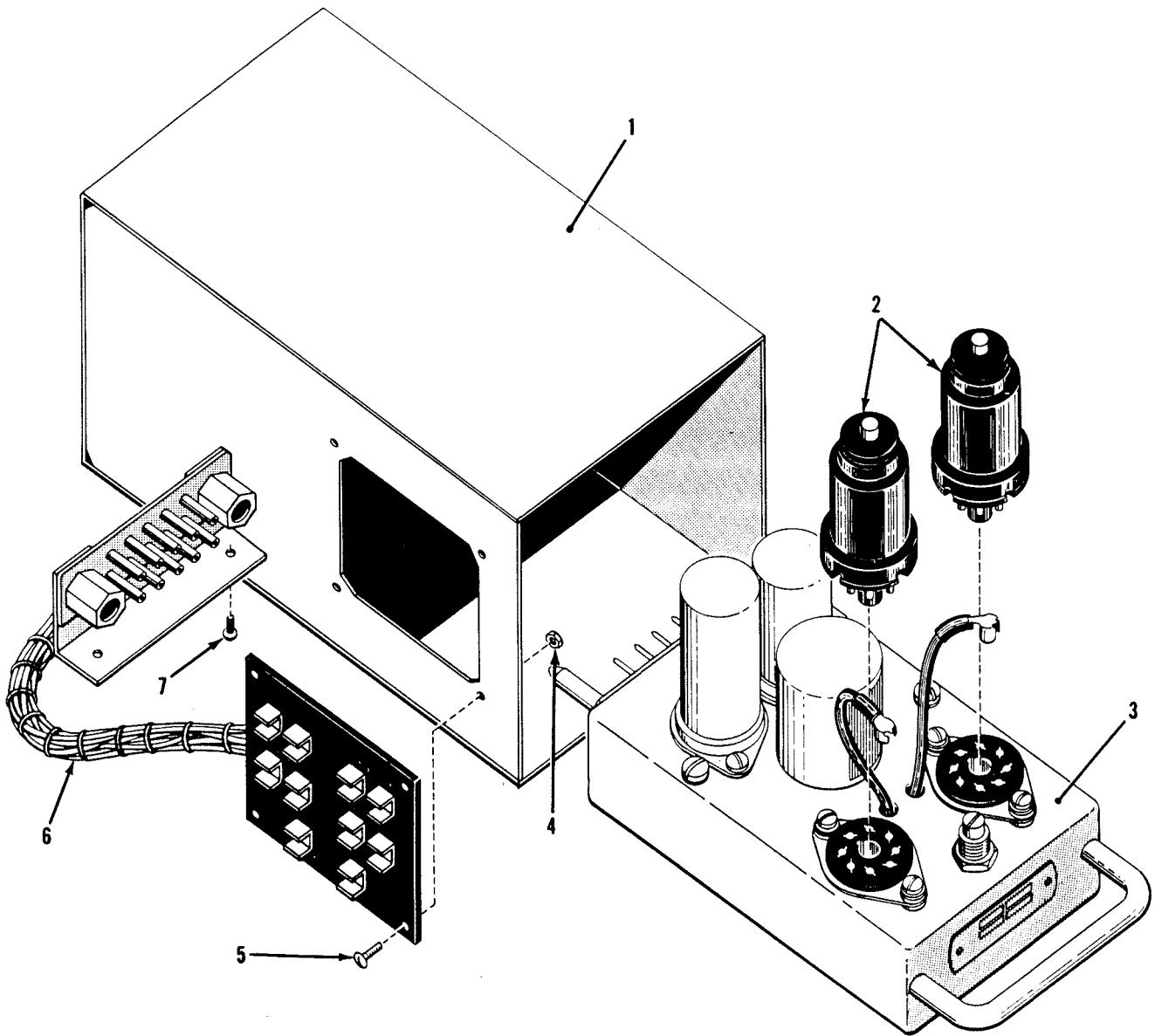

Figure 16. Optical Pre-amplifier.

Index No.	Description	Part No.	Qty. Req'd.
1	Enclosure	3030-506	1
2	Tube	CAT. NO. 3051	2
3	Optical pre-amplifier	CAT. NO. 3050	1
4	Nut, hex, No. 6-32	X-8010-2	4
5	Screw, machine, rd hd, No. 6-32 x 5/16	X-212-2	4
6	Cable assembly	3030-114	1
7	Screw, self tapping, type Z, No. 4 x 3/16	X-9506-2	2

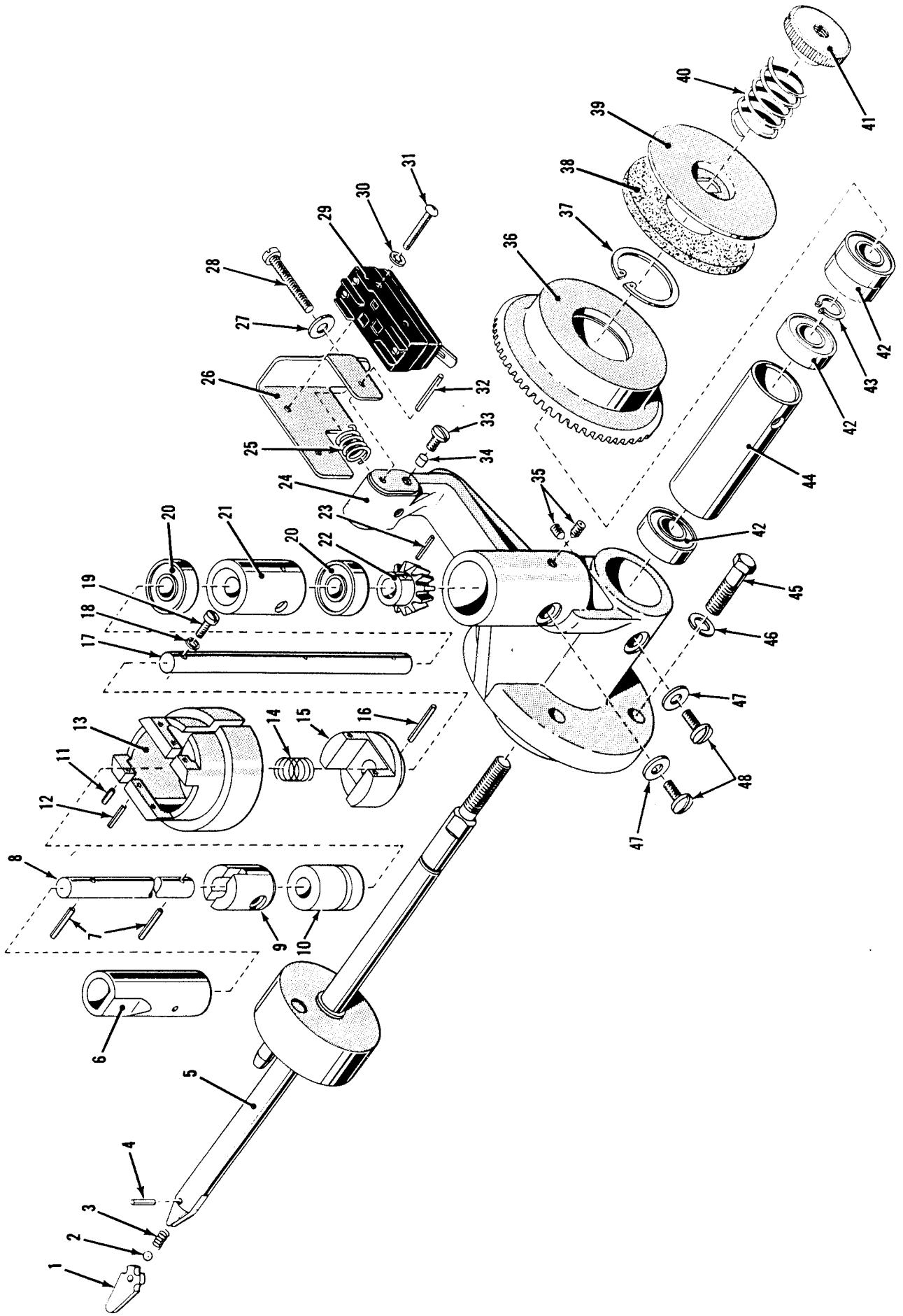

Figure 17. Take-Up Drive Assembly Cat. No. 3032.

TAKE-UP DRIVE ASSEMBLY NO. 3032  
(Parts 6, 7 and 8 not included.)

Index No.	Description	Part No.	Qty. Req'd.
1	Reel drive latch	3030-29	1
2	Ball	B35-14	1
3	Latch spring	3030-30	1
4	Roll pin	X-50377	1
5	Shaft and driving hub assembly	3030-509	1
*6	Coupling	3030-54	1
*7	Roll pin	X-50402	2
*8	Coupling shaft	3030-53	1
9	Coupling	3030-5	1
10	Bushing	3030-10	1
11	Roll pin	X-50227	4
12	Roll pin	X-50468	2
13	Counterweight	3030-7	1
14	Spring	3030-24	1
15	Counterweight coupling	3030-9	1
16	Roll pin	X-50469	1
17	Shaft	3030-6	1
18	Washer, spring lock	X-16230-2	1
19	Screw	X-990-2	1
20	Ball bearing	3030-11	2
21	Bearing separator	3030-12	1
22	Bevel pinion	3030-13	1
23	Roll pin	X-50377	1
24	Bracket, take-up drive	3030-4	1
25	Spring	3030-20	1
26	Bracket, limit switch	3030-21	1
27	Washer	X-16020-2	1
28	Screw	X-18248-2	1
29	Microswitch	3030-22	1
30	Washer	X-16306-2	2
31	Screw	X-248-2	2
32	Roll pin	X-50470	1
33	Screw	X-34224-2	1
34	Locking plug	3030-23	1
35	Setscrew	X-25475	2
36	Bevel gear	3030-14	1
37	Snap ring	X-50472	1
38	Friction disk	3030-16	1
39	Pressure disk	3030-15	1
40	Spring	3030-19	1
41	Friction nut	3030-17	1
42	Ball bearing	3030-50	4
43	Snap ring	X-50473	1
44	Bearing separator	3030-18	1
45	Cap screw	X-5456-2	4
46	Washer, spring lock	X-16222-2	4
47	Washer	X-16020-2	2
48	Screw	X-34228-2	2

\* These parts not included in 3032 assembly.

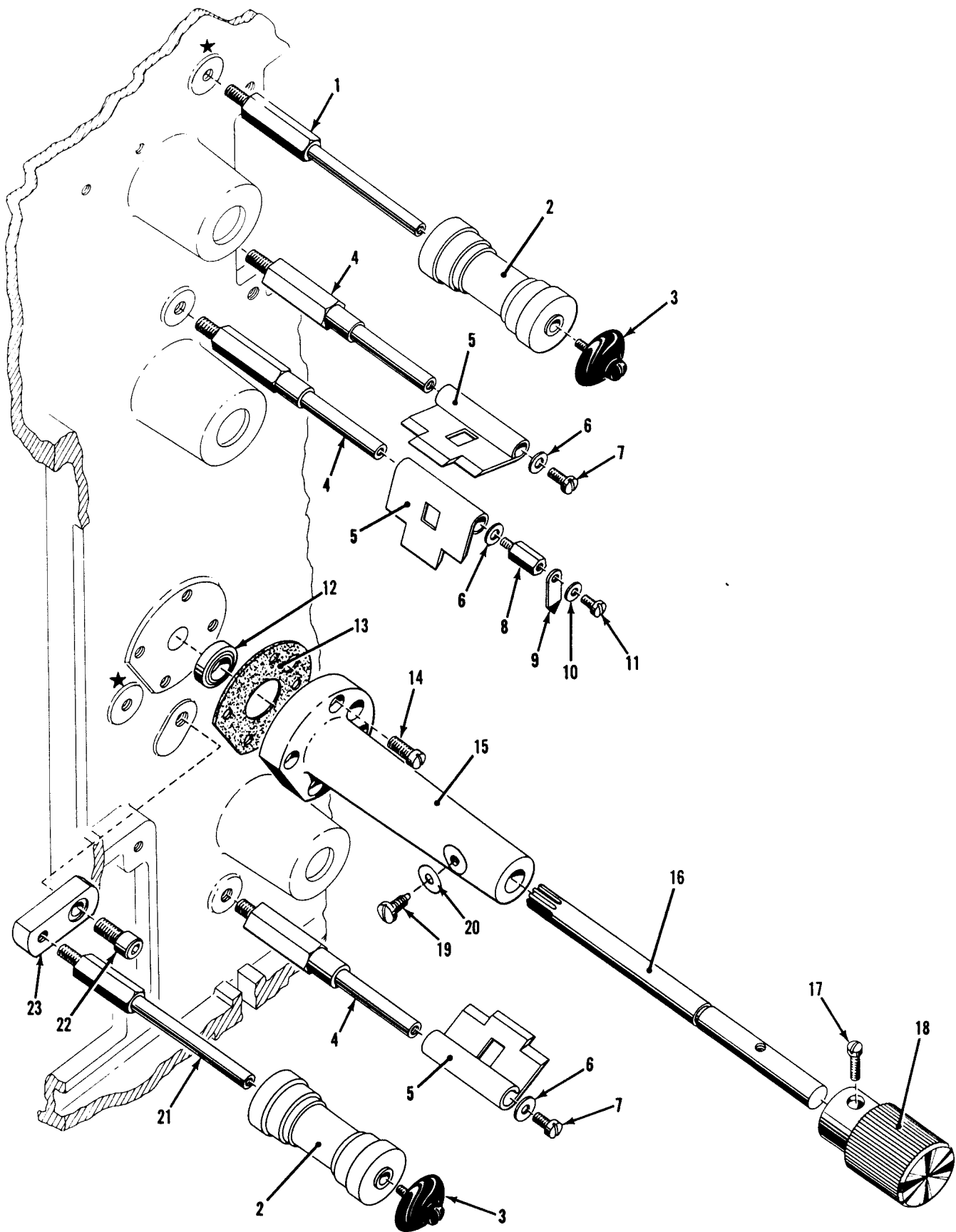

Figure 18. Guide Rollers, Film Strippers, and Framing Shaft Assembly.

GUIDE ROLLERS\*, FILM STRIPPERS, AND FRAMING SHAFT ASSEMBLY

Index No.	Description	Part No.	Qty. Req'd.
* 1	Mounting stud	C1 406 97	2
* 2	Roller	P5 635 26	3
* 3	Cap	C1 407 79	3
4	Mounting stud	C1 050 69	3
5	Film stripper	C1 050 67	3
6	Washer	X-16020-4	3
7	Screw	X-18212-4	2
8	Stud for pointer	C1 704 11	1
9	Threading position pointer	C1 704 10	1
10	Washer	X-16015-4	1
11	Screw	X-966-4	1
12	Oil seal	C1 050 56	1
13	Gasket	C1 050 71	1
14	Screw	X-1164-4	4
15	Framing shaft bracket	C1 050 41	1
16	Framing shaft	C1 050 53	1
17	Screw	X-18224-4	1
18	Framing knob	C1 703 90	1
19	Screw	C1 050 52	1
20	Washer	X-16315	1
21	Mounting stud	C1 407 01	1
22	Screw	X-19628	1
23	Arm	C1 406 99	1

\* The parts marked with an asterisk are common to the guide rollers located by a star in Figure 18.



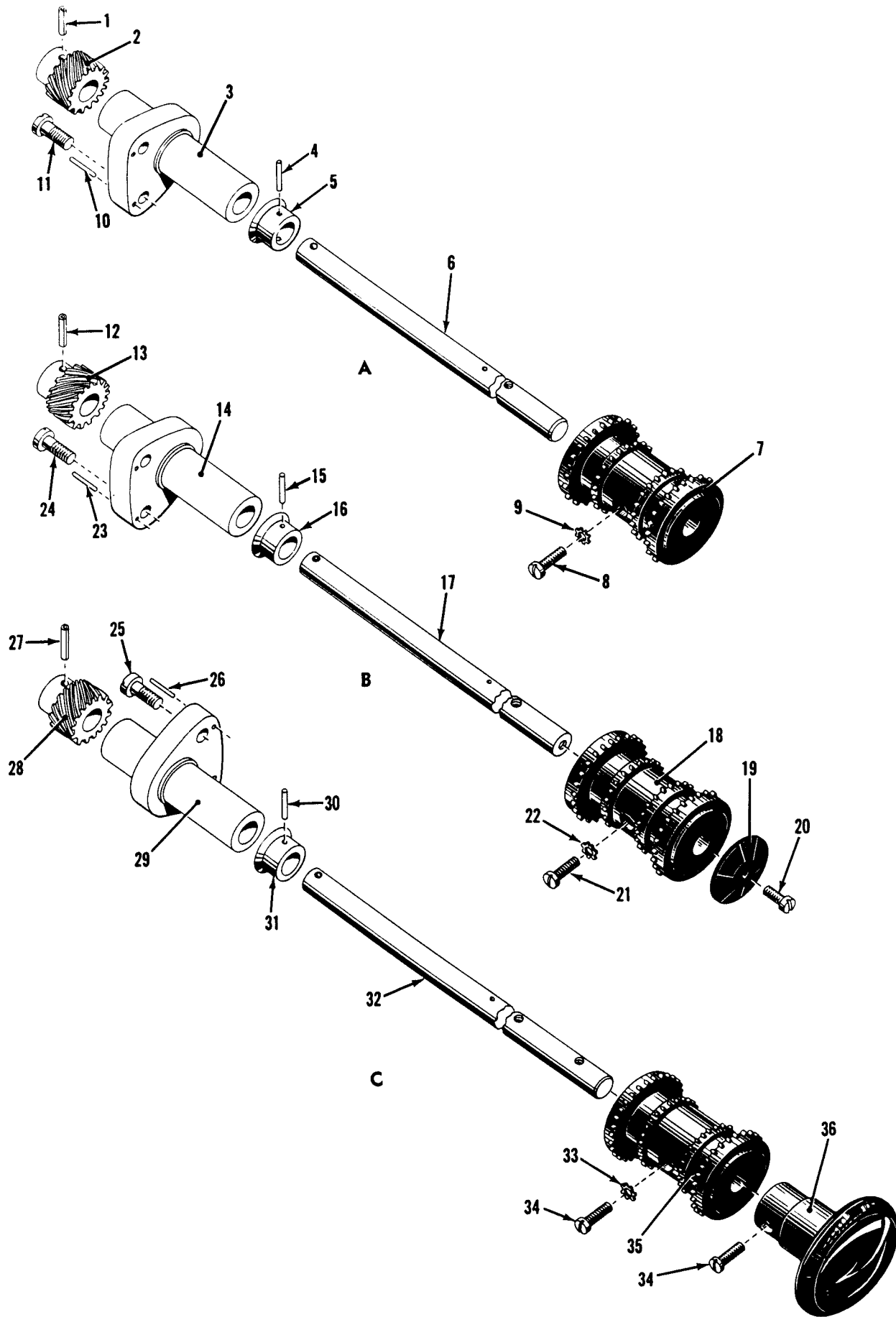

Figure 19. Bracket Assemblies; Upper Feed, Intermediate, and Hold-Back Sprockets.

BRACKET ASSEMBLIES; UPPER FEED, INTERMEDIATE, AND HOLD-BACK SPROCKETS

Index No.	Description	Part No.	Qty. Req'd.
<b>A. Upper Feed Sprocket Bracket Assembly</b>			
	Upper feed sprocket shaft assembly	C1 750 37	1
1	Roll pin	X-50539	1
2	Gear (right-hand)	C1 750 34	1
3	Bracket	C1 750 33	1
4	Roll pin (not available separately)	C1 705 55	1
5	Oil slinger (not available separately)		1
6	Shaft (not available separately)		1
7	Upper feed sprocket	C1 703 37	1
8	Screw	X-18224-4	1
9	Washer	X-16334	1
10	Dowel pin	B 042 AA/3X16	2
11	Screw	X-18224-2	2
<b>B. Intermediate Sprocket Shaft Assembly</b>			
	Intermediate sprocket shaft assembly	C1 704 08	1
12	Roll pin	X-50539	1
13	Gear (left-hand)	C1 750 35	1
14	Bracket	C1 750 33	1
15	Roll pin (not available separately)	C1 705 57	1
16	Oil slinger (not available separately)		1
17	Shaft (not available separately)		1
18	Intermediate sprocket	C1 703 37	1
19	Threading position indicator	C1 704 09	1
20	Screw	X-18206-4	1
21	Screw	X-18224-4	1
22	Washer	X-16334	1
23	Dowel pin	B 042 AA/3X16	2
24	Screw	X-18224-2	2
<b>C. Hold-Back Sprocket Bracket Assembly</b>			
25	Screw	X-18224-2	2
26	Dowel pin	B 042 AA/3X16	2
	Hold-back sprocket shaft assembly	C1 750 38	1
27	Roll pin	X-505 39	1
28	Gear (right-hand)	C1 750 34	1
29	Bracket	C1 750 33	1
30	Roll pin (not available separately)	C1 705 56	1
31	Oil slinger (not available separately)		1
32	Shaft (not available separately)		1
33	Washer	X-16334	1
34	Screw	X-18224-4	2
35	Hold-back sprocket	C1 703 38	1
36	Knob	23 705 04	1

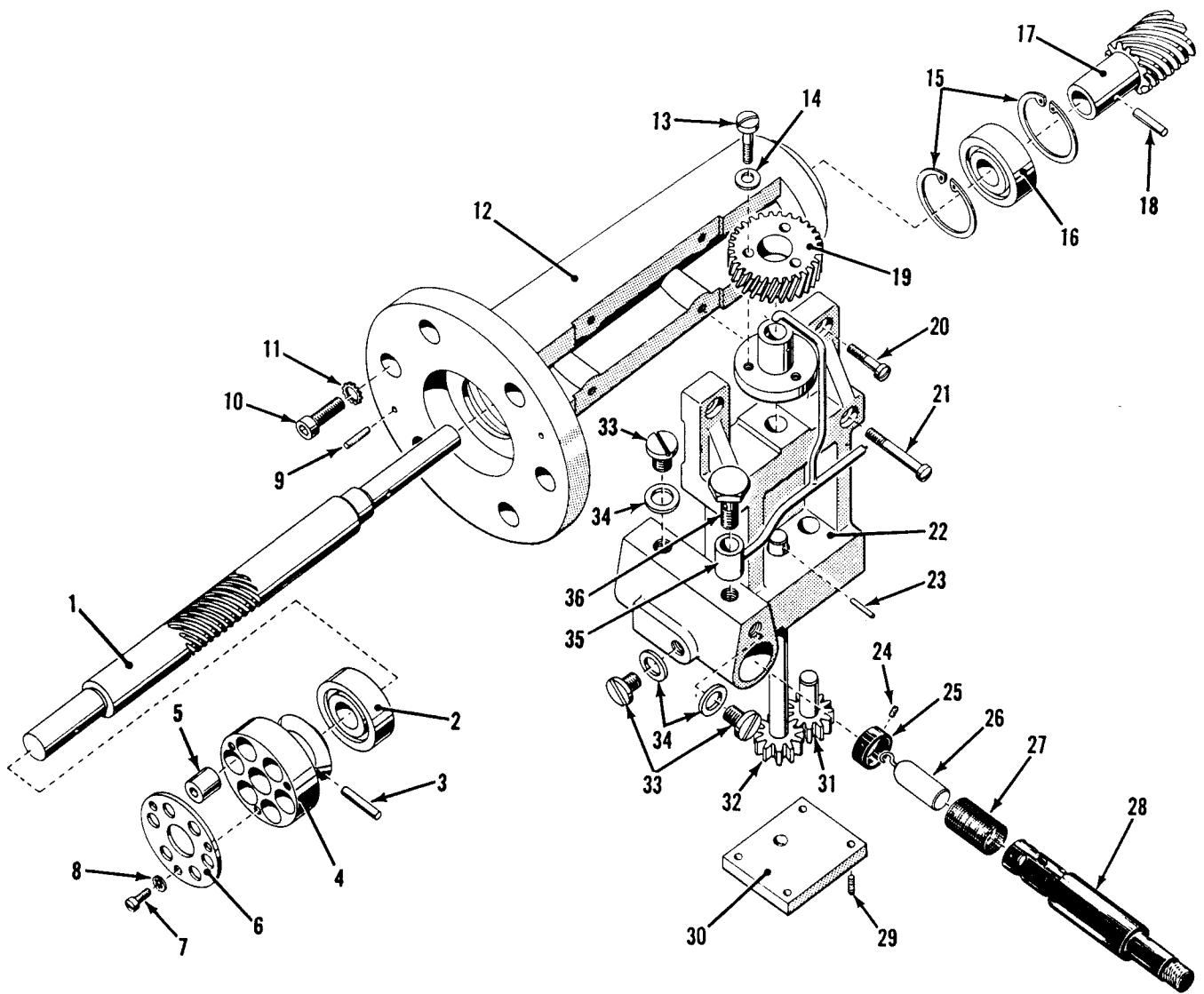

Figure 20. Oil Pump and Motor Drive Shaft.

OIL PUMP AND MOTOR DRIVE SHAFT

Index No.	Description	Part No.	Qty. Req'd.
	Oil pump, complete	C1 750 61	1
	Motor drive shaft assembly ✓	C1 705 52	1
1	Motor drive shaft		1
2	Ball bearing (available separately) ✓	89 181 07	1
3	Locking pin		1
4	Driving hub		1
5	Rubber bushing	C1 750 65	6
6	Retaining ring	C1 750 71	1
7	Screw	X-972-2	3
8	Washer	X-16309	3
9	Pin	B 042 AA/4X16	2
10	Screw	X-19628	6
11	Washer	X-16337	6
12	Drive shaft bracket	C1 750 69	1
13	Screw	X-18230-2	3
14	Washer	X-16312	3
15	Retaining ring	07 892 35	2
16	Ball bearing	89 181 07	1
17	Motor drive shaft gearwheel <sup>Key Set</sup>	<del>C1 750 66</del> C1-754 65	1
18	Locking pin	X-50539	1
19	Fiber gear	C1 750 57	1
20	Screw	X-18230-2	2
21	Screw	X-18254-2	2
22	Oil pump body	C1 750 52	1
23	Pin (not available separately)		1
	Oil filter assembly (24 through 28)	22 417 00	1
24	Setscrew	07 853 04	3
25	Ring	22 449 99	1
26	Magnet	22 414 44	1
27	Screen	22 448 00	1
28	Oil filter body	22 416 98	1
29	Screw	X-972-2	4
30	Impeller cover plate	C1 750 53	1
31	Impeller, short shaft	C1 705 51	1
32	Impeller, long shaft, with pin and gear hub	C1 705 50	1
33	Plug	C1 750 60	3
34	Gasket	C1 750 59	3
35	Oil line	C1 750 96	1
36	Oil feeder line coupling	C1 750 63	1

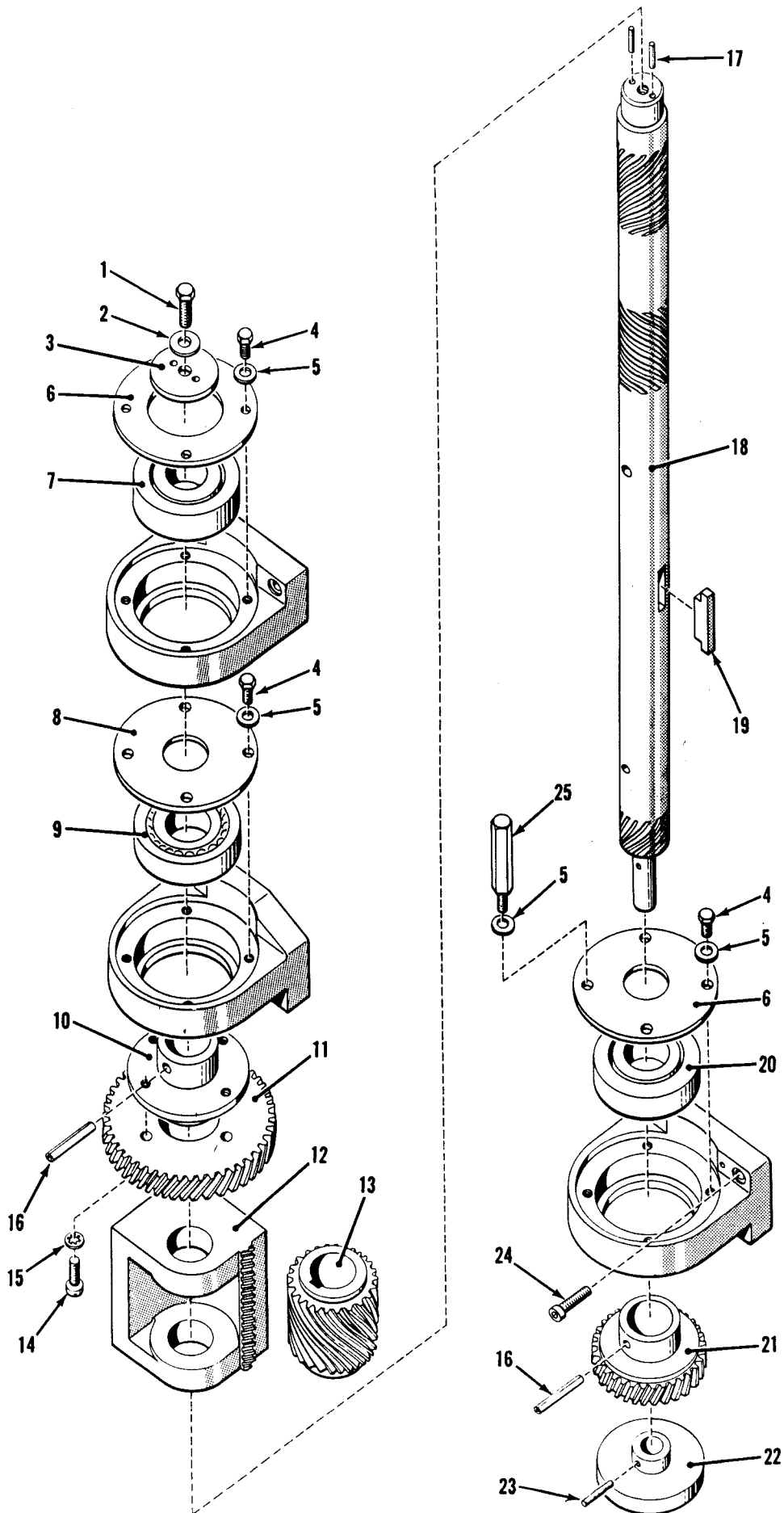

Figure 21. Main Shaft Assembly C1 750 50.

MAIN SHAFT ASSEMBLY C1 750 50

Index No.	Description	Part No.	Qty. Req'd.
1	Screw	X-5342-2	1
2	Washer	X-16025-2	1
3	Thrust washer	C1 750 43	1
4	Screw	X-19406-2	11
5	Washer	X-16015-2	12
6	Retaining ring	C1 750 44	1
7	Ball bearing	89 225 18	1
8	Retaining ring	C1 750 41	2
9	Ball bearing, self adjusting	89 186 10	1
10	Hub (not available separately)		1
11	Fiber gear	C1 750 24	1
12	Fork	C1 750 10	1
13	Worm gear, intermittent drive	C1 750 09	1
14	Screw	X-18224-2	4
15	Lockwasher, internal tooth	X-16312	4
16	Locking pin	X-50541	2
17	Dowel	07 595 22	2
18	Shaft (not available separately)		1
19	Key	C1 704 54	1
20	Ball bearing	89 181 10	1
21	Main drive gear <sup>← GEAR</sup> 567	<del>C1 750 48</del> C1-754-65	1
22	Oil slinger	C1 750 49	1
23	Locking pin	X-50396	1
*24	Screw	X-18224-2	10
25	Stop for fork	C1 704 55	1

\* Not included with main shaft assembly No. C1 750 50.

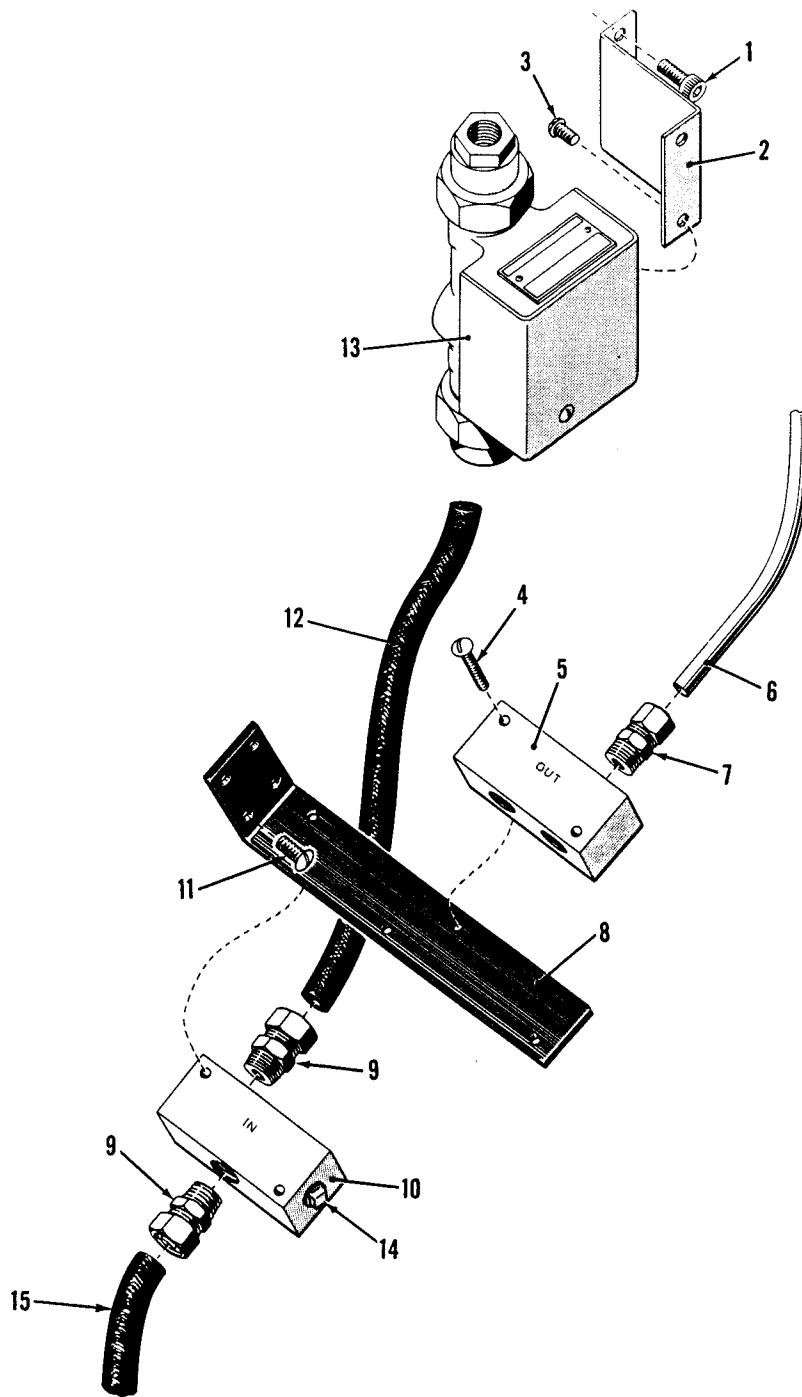

Figure 22. Water Manifolds and Flow Switch.

Index No.	Description	Part No.	Qty. Req'd.
1	Cap screw, socket hd, 1/4-20 x 1/2 in.	X-19526	2
2	Flow switch bracket	3030-86	1
3	Screw, machine, rd hd, No. 10-32 x 3/8	X-19102	2
4	Screw, machine, rd hd, No. 10-32 x 1 in.	X-19138	4
5	Water outlet manifold	3030-91	1
6	Copper tubing, 5/16 in. OD	3030-103	
7	Compression fitting	3030-101	3
8	Water manifold bracket	3030-82	1
9	Flexible hose fitting (not reusable)	3030-99	8
10	Water inlet manifold	3030-81	1
11	Screw, machine, rd hd, No. 10-32 x 1/2	X-19114	4
12	Water hose, short	3030-109	1
13	Flow switch	3030-85	1
14	Pipe plug	X-50507	1
15	Water hose, long	3030-108	3

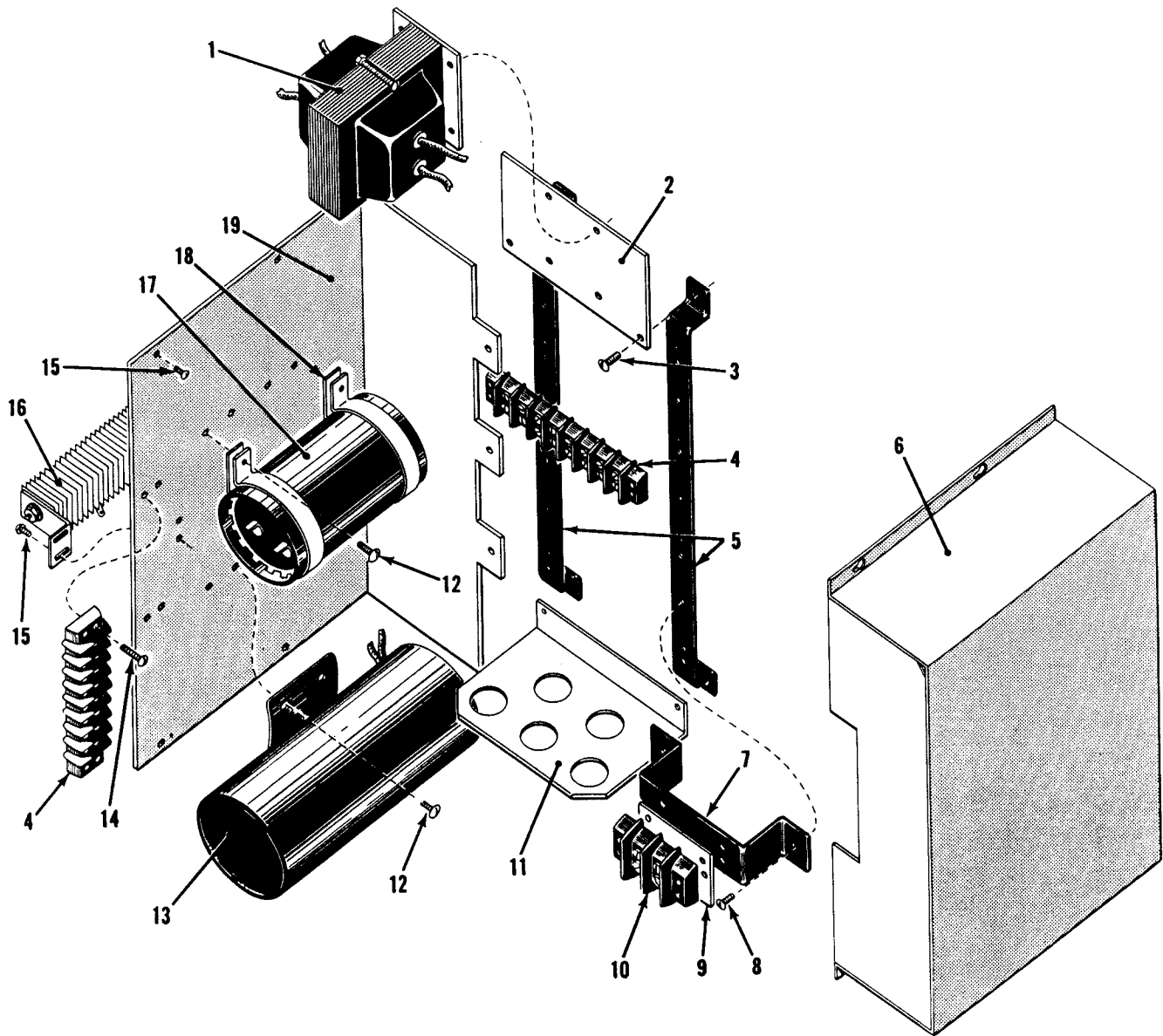

Figure 23. Electrical Components I.

Index No.	Description	Part No.	Price	Qty. Req'd.
1	Transformer	3030-115	7.33	1
2	Transformer bracket	3030-121		1
3	Screw, machine, rd hd, No. 10-32 x 1/2 in.	X-19114-2		4
4	Terminal strip	3030-97		5
5	Bracket	3030-87		2
6	Cover	3030-507		1
7	Bracket	3030-147		2
8	Screw, machine, rd hd, No. 8-32 x 3/8 in.	X-308-2		4
9	Marker, 120-volt ac	3030-160		1
	Marker, arc lamp relay	3030-161		1
10	Terminal strip	3030-149		2
11	Anchor plate	3030-120		1
12	Screw, machine, rd hd, No. 10-32 x 3/8 in.	X-19102-2		8
13	"Run" capacitor	3063-3		2
14	Screw, machine, rd hd, No. 6-32 x 1/2 in.	X-230-2		20
15	Screw, machine, rd hd, No. 6-32 x 3/16 in.	X-200-2		8
16	Rectifier	3030-123	17.90	1
17	"Start" capacitor	3063-2	7.33	2
18	Clip	X-34355		4
19	Capacitor bracket	3030-117		1



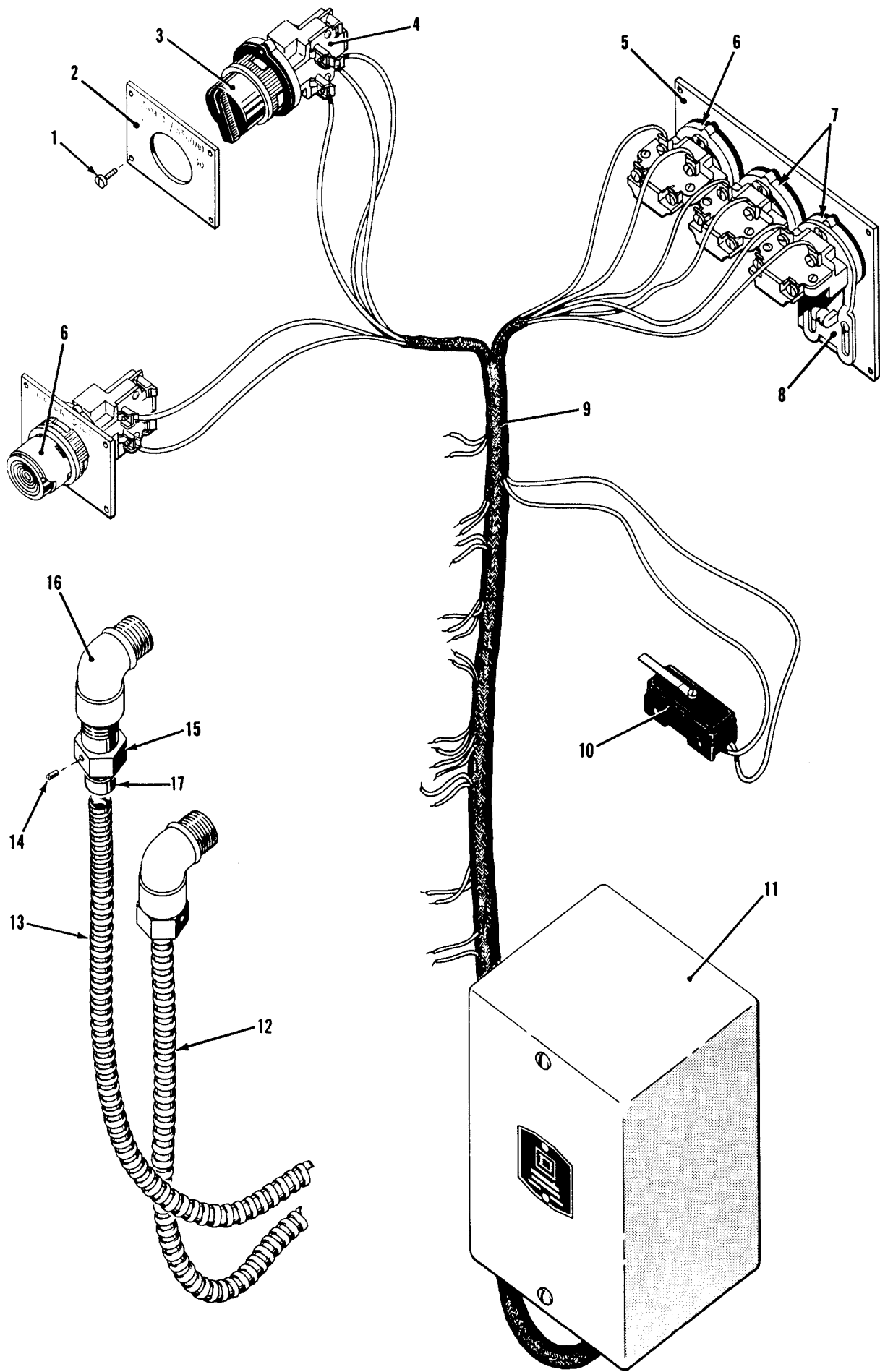

Figure 24. Electrical Components II.

## ELECTRICAL COMPONENTS II

Index No.	Description	Part No.	Qty. Req'd.
1	Screw, machine, fil hd, No. 6-32 x 5/16 in.	X-882-4	13
2	Switch plate, speed selector	3030-69	1
3	Selector switch operator	3030-92	1
4	Contact block	3030-96	5
5	Switch plate, motor and arc lamp	3030-70	1
6	Pushbutton operator, red	3030-94	3
7	Pushbutton operator, black	3030-93	2
8	Maintained contact attachment	3030-107	1
9	Harness	3030-124	1
10	Microswitch	3030-22	1
11	Motor start contactor	3030-98	1
12	Flexible conduit	3030-105	1
13	Flexible conduit	3030-106	1
14	Setscrew, No. 8-32 x 1/4 in.	X-20706	4
15	Cable clamp	3030-89	4
16	Conduit elbow	3030-110	2
17	Insulating bushing	3030-122	4

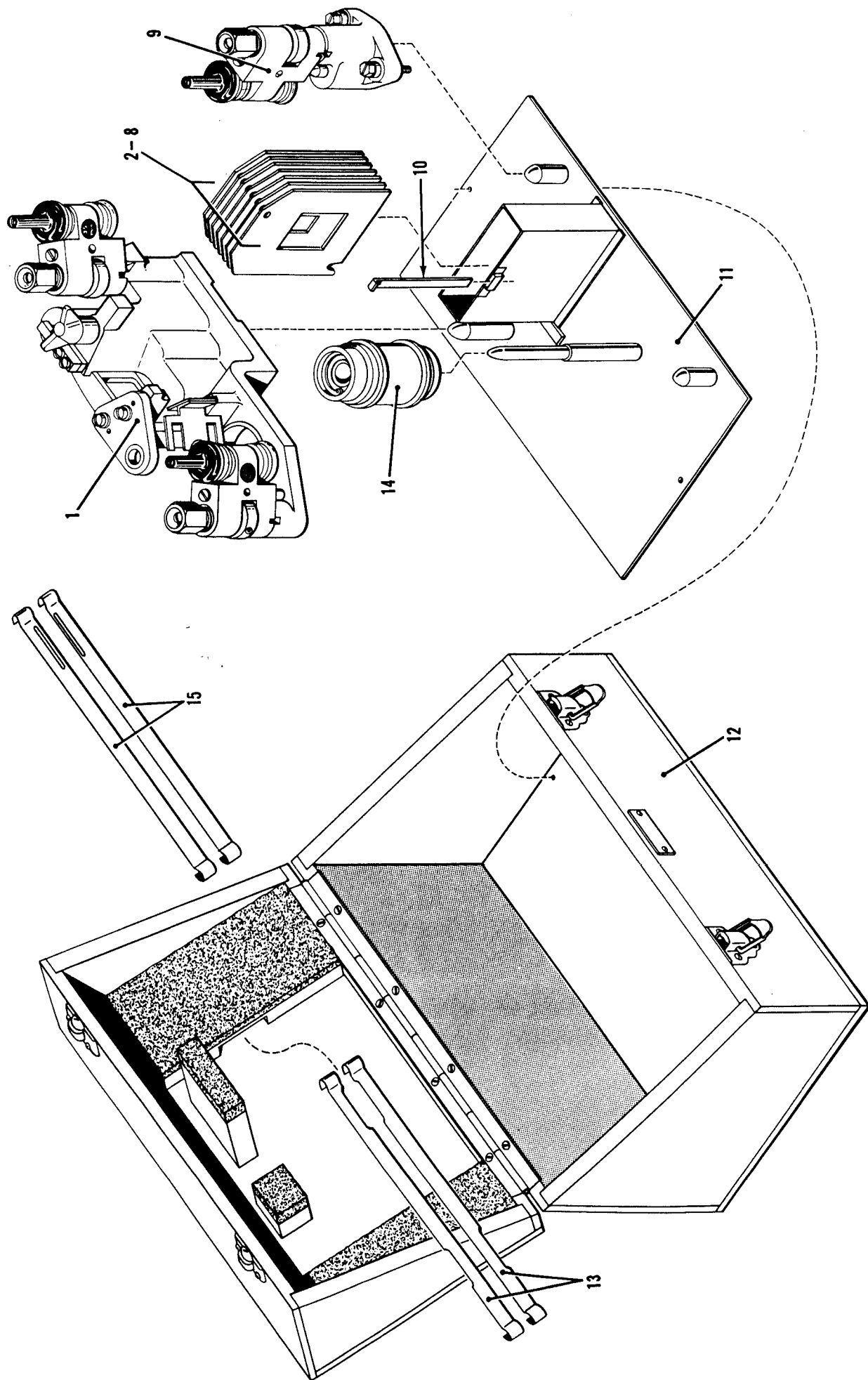

Figure 25. 35mm Conversion Parts and Chest Cat. No. 3018

35MM CONVERSION PARTS AND CHEST CAT. NO. 3018

Index No.	Description	Part No.	Qty. Req'd.
1	35mm gate assembly	C1 606 34	1
2	Aperture plate, 35mm standard	C1 704 64	1
3	Aperture plate, cinemascope, magnetic	C1 704 65	1
4	Aperture plate, cinemascope, optical	C1 704 66	1
5	Aperture plate, 35mm, 1.75:1 ratio	C1 704 67	1
6	Aperture plate, 35mm, 1.85:1 ratio	C1 704 68	1
7	Aperture plate, 35mm, 2.00:1 ratio	C1 704 69	1
8	Aperture plate, 70mm, droopsnoot blank	C1 704 71	1
9	35mm pad roller assembly	C1 606 29	2
10	Pressure band lifter	C1 704 91	1
	Chest assembly (includes 11 and 12)	C1 705 13	1
11	Rack	C1 705 01	1
12	Chest	C1 705 12	1
13	35mm pressure bands	CAT. NO. 3017	2 pr.
14	35mm pressure roller assembly	C1 606 53	1
15	70mm pressure bands	CAT. NO. 3016	1 pr.

**ROBERT B. WARMAN, INC.**

P. O. BOX 2385, BUFFALO 23, N. Y., TELEPHONE, WInDsor 1500

