

Film-Tech

The information contained in this Adobe Acrobat pdf file is provided at your own risk and good judgment.

These manuals are designed to facilitate the exchange of information related to cinema projection and film handling, with no warranties nor obligations from the authors, for qualified field service engineers.

If you are not a qualified technician, please make no adjustments to anything you may read about in these Adobe manual downloads

www.film-tech.com

Century®

PROJECTOR MECHANISM

Instruction Manual & Parts List

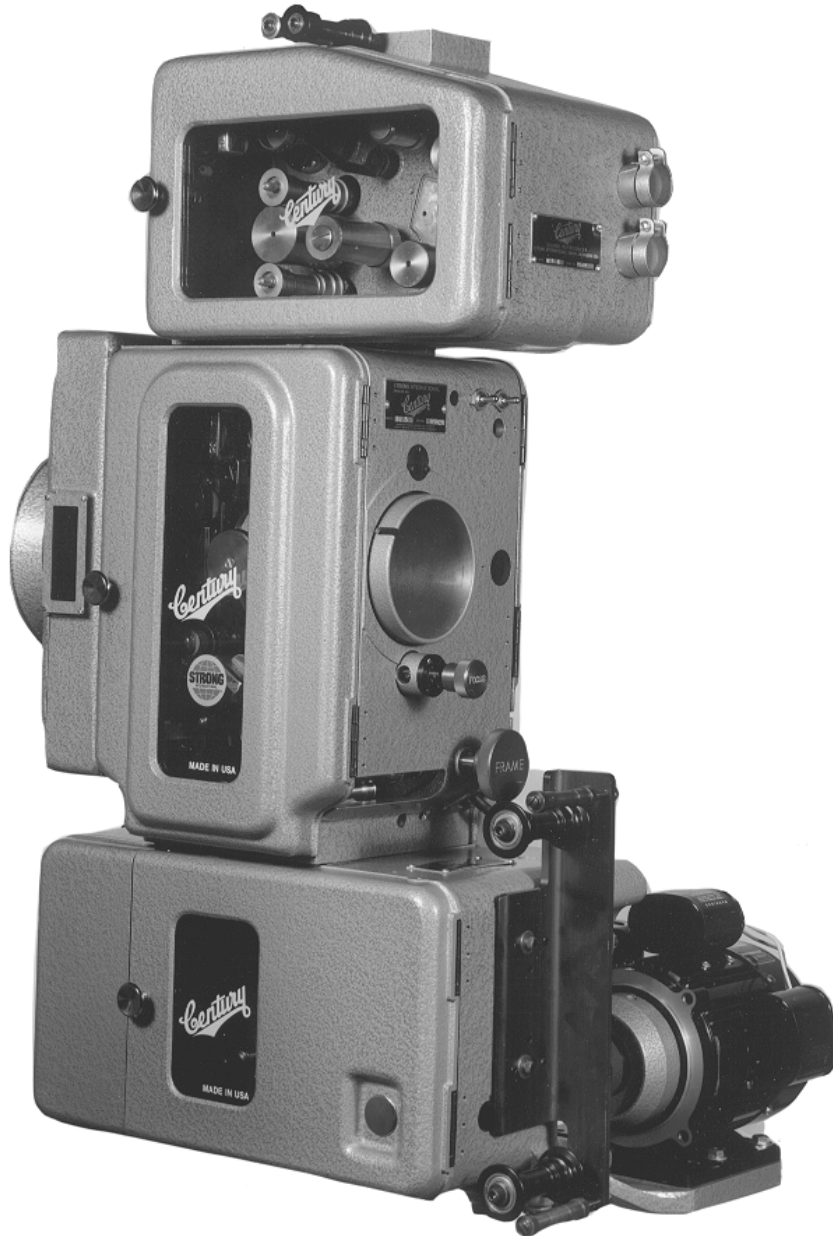

**STRONG
INTERNATIONAL**
a division of Ballantyne of Omaha, Inc.
4350 McKinley Street
Omaha, Nebraska 68112 USA
Tel 402/453-4444 • Fax 402/453-7238

Model "JJ"
35/70mm
with R-31E
Penthouse

CONTENTS

Preface	1
Figure 1	2
Figure 2	3
Installation.....	4
Threading	10
Conversion, 35/70mm	17
Initial Operation	18
Maintenance	20
Figure 3	22
Adjustments & Replacements	23
Projector Parts Catalog.....	37
R31E Magnetic Soundhead	83

STRONG INTERNATIONAL

a division of Ballantyne of Omaha, Inc.
4350 McKinley Street
Omaha, Nebraska 68112 USA
Tel 402/453-4444 • Fax 402/453-7238
Issue 5/99

PREFACE

THE CENTURY "JJ" PROJECTOR combines rugged construction with ease of operation, providing a superior 35/70mm mechanism for the modern cinema. High engineering standards in manufacturing, and a worldwide network of support through Strong International Dealers, insure long years of dependable operation.

A SINGLE-UNIT MAIN FRAME CASTING provides a sturdy foundation for all moving parts. The roomy film compartment permits ease of threading and cleaning. The gear compartment is accessible behind a hinged access door. The "JJ" lens barrel accepts four-inch (101.6mm) diameter lenses. The lens barrel is securely anchored to the main frame to insure holding lenses on optical center.

AN OPTIONAL Century lens turret is available in either Automatic or Manual configuration, and no Magnacom lens is required for either turret. Each lens may be individually fine focused by means of separate control knobs. A dual aperture plate incorporates both anamorphic (CinemaScope) and "flat" formats. The TA Auto Turret accommodates standard (72mm diameter) lenses and features a motor-driven dual aperture plate for fast, quiet format changes. The optional TA-3 Turret makes provision for a third "special" lens and aperture. A solid-state turret control module responds to automation cues.

ALL FILM-BEARING COMPONENTS are designed to minimize print wear and to simplify routine maintenance. The curved film gate and trap can be quickly removed without tools to accommodate 35/70mm conversion and to encourage frequent cleaning. Gate tension can be adjusted while the machine is running. Lateral guide rollers and studio guides mounted to the trap minimize "side weave." Water cooling of the 35/70mm "JJ" trap is mandatory.

THE INTERMITTENT MOVEMENT runs in a sealed oil bath for constant lubrication. The oil level is visible through a sight glass on the operator's side of the mechanism in the film compartment. Framing is accomplished by raising or lowering the movement on a rack and pinion operated by a front-mounted knob. The spring-loaded intermittent shoes are adjustable independent of the gate tension to minimize picture "jump" without applying excessive gate tension. Like the gate and trap assemblies, the 35 and 70mm intermittent shoe pads are readily interchangeable.

DOUBLE, DISSOLVING SHUTTERS insure crisp light cutoff in both 35 and 70mm formats. The shutter blades are positioned close to the aperture for maximum light efficiency. Air vanes on the rear shutter blade aid trap cooling. Optical design is compatible to modern xenon lamphouse systems.

FIGURE 1

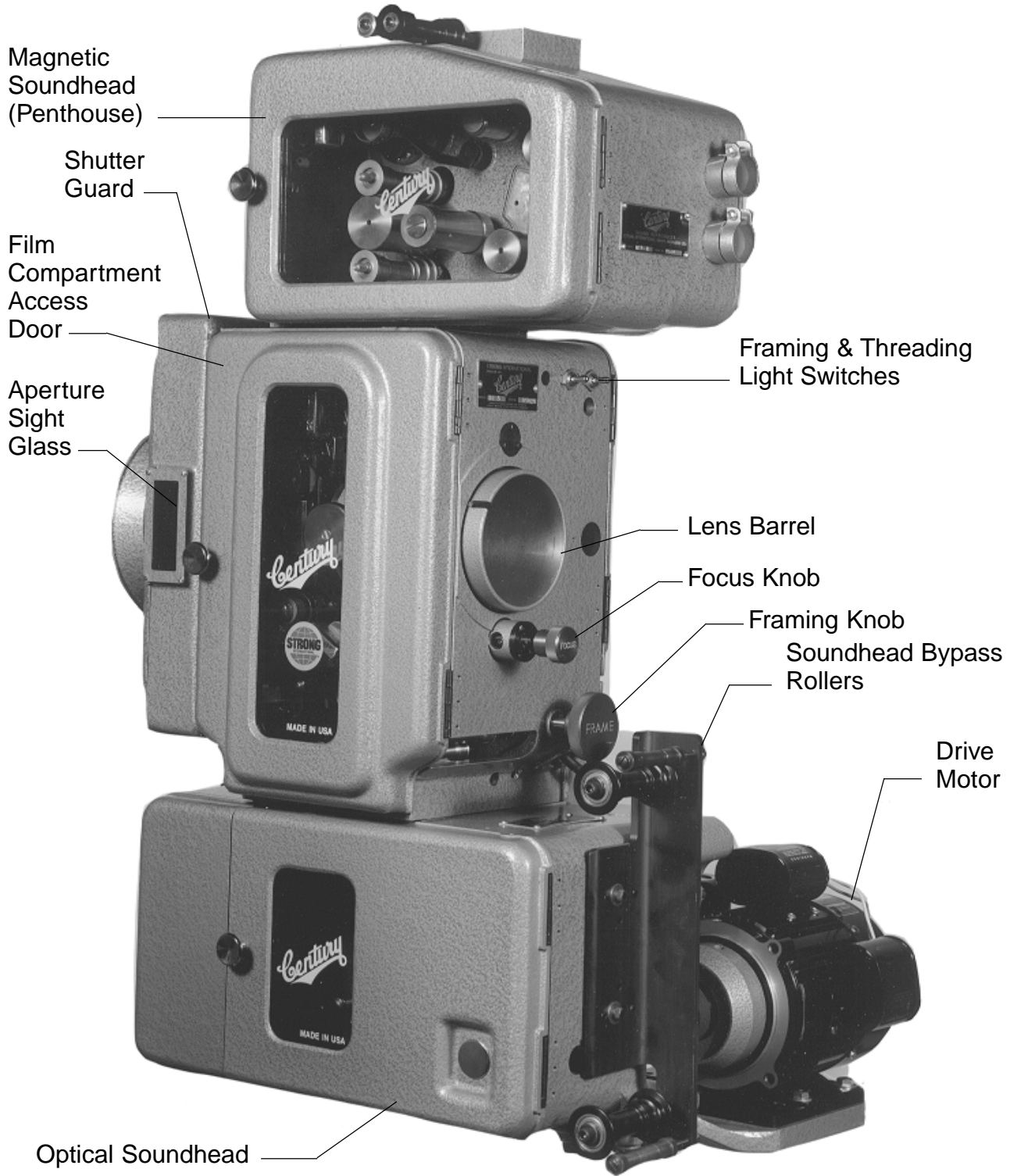
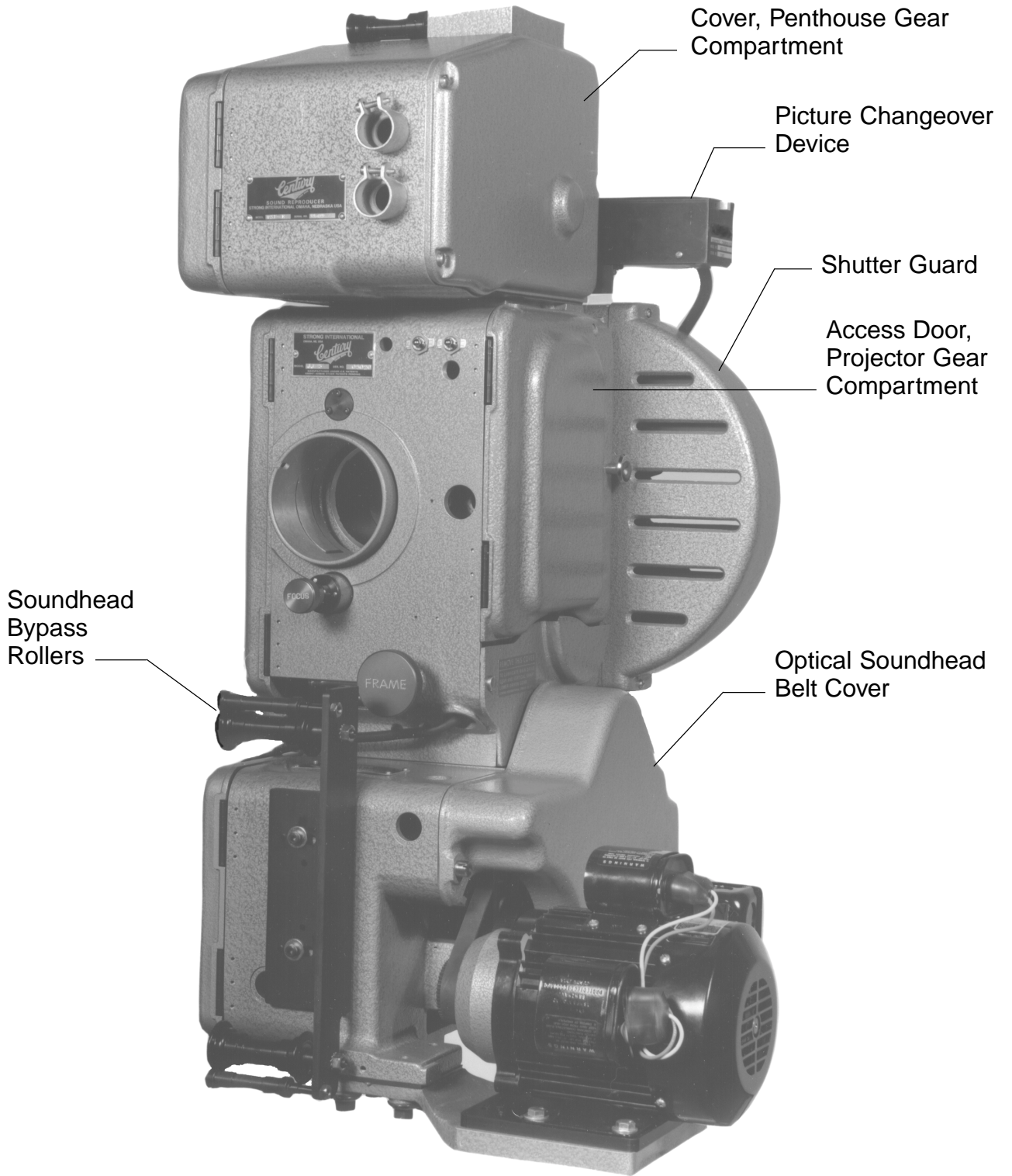

FIGURE 2



INSTALLATION

EACH CENTURY PROJECTOR is carefully inspected and film tested before leaving the factory. Carefully inspect the unit upon receipt for any shipping damage, and file any damage claims with the freight carrier immediately. It is the responsibility of the *consignee*, not Strong International, to file such claims.

THE FOLLOWING RECOMMENDATIONS should be studied carefully prior to installation. Your Strong International Dealer may wish to assist in installing those projection booth components supplied by him.

UNPACKING

The Century "JJ" Projector is shipped as an "All-In-One" system (assembled to the optical soundhead and the magnetic penthouse). The optical soundhead is mounted to the base of the crate with (2) 5/16-18 hex head screws, and (2) 3/8-16 hex head screws secure the top of the crate to the penthouse casting. First remove the 3/8-16 screws from the top of the crate. Then, remove the top of the crate, and disassemble the sides of the crate. Move the projector, on the base pallet, as close as possible to the pedestal or console before removing the 5/16-18 screws from the base.

An accessory kit is shipped with each Century projector. This kit includes the following:

- (1) Bottle Century Projector Oil OL-0004
- (1) Soundhead Damping Fluid FD-0120
- (1) Tube Century Gear Lubricant TU-0380
- (1) Set Allen Wrenches 21-98215
- (1) Framing Lamp Transformer TF-0368

Additional Parts for Non-Turret Projectors:

- (3) Lens Adapters C1-T-160X
- (1) Aperture Plate, Flat
- (1) Aperture Plate, CinemaScope
- (1) Aperture Plate, 70mm

The tools and accessories are required for routine adjustments and preventative maintenance after installation. Store them in a secure location in the projection booth.

MOUNTING

Four holes in the back of the soundhead casting are tapped 3/8-16 and mate to the four mounting holes of a standard projector/soundhead mounting arm of a projection pedestal or projection console. The mounting screws (SC-0600) and washers (WA-0105) are supplied.

Remove the drive side cover casting from the off-operator side of the optical soundhead. Install the flywheel (WH-72) to the impedance drum shaft, with the hub of the flywheel in (facing the mechanism). Tighten the fastening screw securely. Install drive belt(s) and set belt tension by sliding the drive motor on its slotted mounting holes. Replace the soundhead cover casting after installing drive belt(s).

Remove the drive side cover casting from the off-operator side of the magnetic penthouse. Locate and identify the (2) impedance drum flywheels; the large flywheel mounts to the large impedance drum between the lateral guide rollers, and the small flywheel mounts to the smaller impedance drum between the magnetic heads.

Add the Century Damping Fluid supplied (FD-0120) to the cup of the damper assembly in the optical soundhead. The damper assembly is located below the slit lens and impedance drum. Loosen the fluid cup fastening screw (SC-0526), which will allow the cup (CU-0085) to be removed at the bottom. Fill the cup with damping fluid to the groove cut into the inside of the cup. Replace the cup into the assembly, raising the cup all the way up to the shoulder, and tightening the cup fastening screw SC-0526 securely.

Check the oil level of the intermittent movement and add oil as required. The oil level is visible through the sight glass below the intermittent sprocket. Fill to the red line using the Century Projector Oil supplied. The oil fill cup is located on the arm behind the intermittent sprocket. Do not fill over the level indicated. Excess oil will be expelled through the vent holes and the fill cup when the projector is started, and may deposit on the film. **USE ONLY GENUINE CENTURY PROJECTOR OIL.**

Mount the 70mm Soundhead Bypass Roller assembly to the front of the soundhead casting as illustrated on Figures 1 and 2. The 1/4-20 mounting hardware is included in the Accessory Kit. Add FD-0120 Damping Fluid to the penthouse damper fluid reservoir (see page 83) as required

Century JR3-E Optical Soundhead

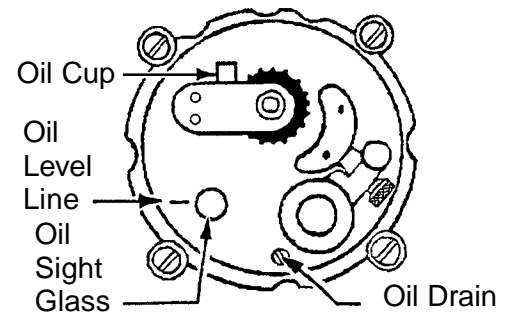
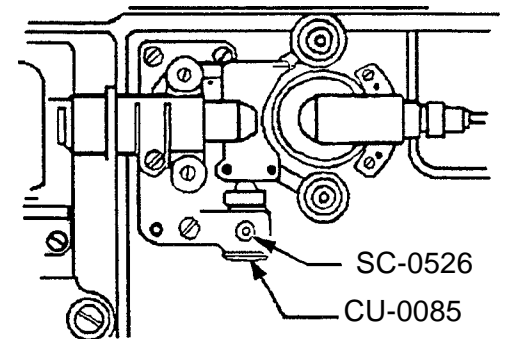

LAMPHOUSE OPTICAL ALIGNMENT

Carefully follow the lamphouse manufacturer's instructions regarding correct optical alignment between the lamphouse and projector. The lamphouse is generally aligned to the projector aperture, but some consoles require positioning the projector and soundhead to the optical center of the lamphouse. DO NOT alter the film path between the projector and soundhead in the course of these adjustments. DO NOT operate the lamphouse with the douser open unless the projector is running.

LAMPHOUSE LIGHT SHIELD

Light shields, or nose cones, are frequently supplied by the lamphouse manufacturer. These may be installed between the projector shutter guard and the lamphouse snood. Make certain that the nose cone does not obstruct the rotation of the shutter blades. Trim or otherwise modify the nose cone as required.

WIRING INSTRUCTIONS

Connect the exciter lamp to a listed power supply. The incandescent exciter lamp used in a direct scan optical soundhead operates on 9 volts, 4 amperes DC. AC exciter output is generally an emergency backup provided by many exciter power supplies. The L.E.D. exciter used for reverse scan optical soundheads, and/or the quartz lamp sometimes used for digital sound scanning, connect to the special power supply furnished with the soundhead. See the soundhead manual for hookup instructions and adjustment procedures. It is highly advisable to have the soundhead alignment checked by a qualified sound technician to correct any adjustments which may be disturbed in shipping.

The Century Projector is normally supplied with either an Essannay ("Zipper") or a Strong 120 V.AC picture changeover device. Connect the changeover leads as follows:

<u>Essannay</u>	<u>Strong</u>
Blk - OPEN	Blk - OPEN
Brn - CLOSE	Red - CLOSE
Wht - COMMON	Wht - COMMON
	Grn - GROUND

NOTE: These changeover devices require a 120 V.AC *pulse* to operate. Connecting the changeover to a **sustained** 120 V.AC supply will **destroy** the electrical coil. Check carefully the instructions supplied with the automation controller or the (installer supplied) switching circuit.

WIRING INSTRUCTIONS (continued)

A stepdown transformer (TF-0368) is provided to supply low voltage (12 V.AC) to the film compartment work light and the aperture framing lamp. Mount the transformer to the projection pedestal or console and apply 120 V.AC to primary terminals 1 and 4; jumpers between 1 & 2 and 3 & 4 (see wiring instructions on the transformer). Connect the 12 V.AC secondary to the projector lamp leads.

The 12 V.AC required by the Auto Turret controllers is also derived from the secondary of the TF-0368 transformer. See the “LENS TURRET” section following for correct terminations.

LENS INSTALLATION (non-Turret Model)

Rotate the focus knob to position the lens barrel at the center of its travel. Lens adapters are supplied for use with 72mm (outside diameter) lenses. If required, loosen the (2) slot head clamping screws in the lens adapter, and insert the adapter into the lens barrel. Seat the locating pin of the adapter into the slot in the lens barrel, and tighten the lens clamping screw.

Install the 35mm “flat” aperture plate in insert the “flat” lens into the lens adapter. Start the projector, ignite the lamphouse, and project a picture to the screen. Move the lens inside the adapter until a sharply focused picture is projected. Carefully remove both the lens and the lens adapter, and secure the (2) lens clamping screws. Reinstall the lens, again seating the locating pin, and check the repeatability of the focused picture. Adjust as required without moving the focus knob.

Install the CinemaScope aperture plate, CinemaScope lens and anamorphic adapter, and repeat the above procedure. In CinemaScope format, carefully check the horizontal plane of the anamorphic correction in addition to focus. Complete the procedure using the 70mm aperture and lens.

File the aperture plates to size the picture to the screen and/or masking. NOTE: when projecting a white light while filing apertures, close the lamphouse douser *frequently* to allow the lens to cool.

LENS TURRET

The MANUAL turret requires no electrical connections. Installer connections to the two-lens automatic turret are made to terminals located on the control box T1-A-101, or to control chassis 82-70055 for the three-lens turret. Both controllers are powered by a 12 V.AC feed from the TF-0368 stepdown transformer. The FLAT, SCOPE, and SPECIAL inputs are derived from an automation controller and/or other installer-supplied circuitry.

NOTE: “SPECIAL” input applies only to a *third lens* in a three-lens turret.

LENS TURRET (continued)

Two-Lens Turret

Mount the two-lens turret controller T1-A-101 to the projection pedestal or console. Interconnect the turret controller to the booth automation as follows:

<u>Terminal No.</u>	<u>Function</u>
1	Scope Format Input
2	Toggle *
3	Flat Format Input
4	Common Format Input
5	Motor (Black)
6	Motor (Red)
7	12 V.AC
8	12 V.AC

* For use with *installer-supplied* Lens Reset Switch (optional)

Three-Lens Turret

Mount the three-lens turret control chassis 82-70055 to the projection pedestal or console. Connect leads as shown below.

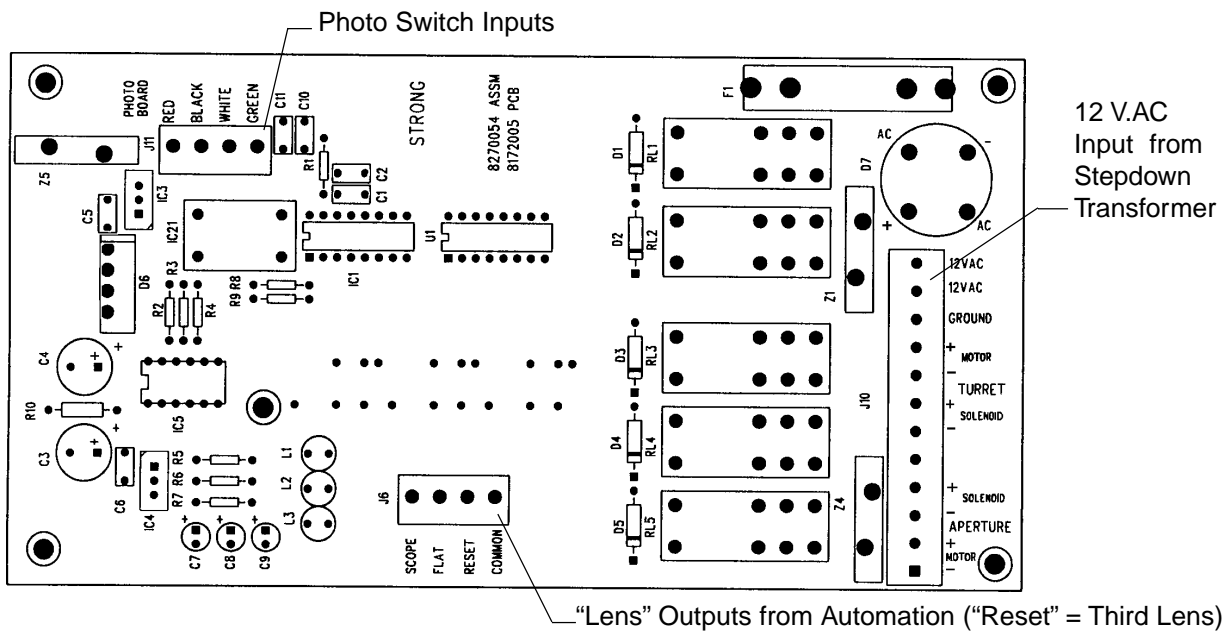

LENS INSTALLATION (TURRET)

The lens barrels are individually marked to designate their screen format. The barrels of the standard two-lens turret are marked SCOPE (CinemaScope, or anamorphic) and FLAT (wide screen, non-anamorphic). The additional barrel in the three-lens turret is marked SPECIAL. The lenses must be installed in their correct barrels for correct aperture logic. Magnacom lenses are not required in any configuration.

Rotate the turret to the SCOPE position. The automatic turret will index to this position after the SCOPE switch is pressed; the manual turret must be indexed by hand. Make certain the SCOPE aperture plate is in position. Center the focus adjustment screw, allowing equal travel forward and back. Insert the CinemaScope lens and anamorphic adapter into the SCOPE barrel. Start the projector, ignite the lamphouse, and project a picture to the screen. Move the lens inside the barrel until a sharply focused picture is projected, and the anamorphic correction is on the correct horizontal plane. Securely tighten the lens locking knob on the top of the SCOPE barrel. Close the lamphouse douser.

Reset the turret to FLAT format, and make certain the FLAT aperture is in position. Center the focus adjustment screw, and insert the FLAT lens. Open the lamphouse douser and move the lens inside the barrel until a sharply focused picture is projected. Tighten the lens locking knob above the FLAT lens barrel.

Repeat the above procedures as required for the “special” lens used in a three-lens turret. Once installed, DO NOT remove the lenses for cleaning. The turret is hinged, and opens to permit cleaning the rear surfaces of the lenses.

Two round steel bushings are located at the top of the aperture changer and are mounted with small (4-40) socket head screws. These bushings serve as stop pins to limit the travel of the aperture plate. The (2) bushings are eccentric, and furnish a slight degree of adjustment by loosening the socket head screws and rotating the bushings. Make certain the aperture travel is acceptable, and the bushings are secure, before filing the aperture plate.

To remove the aperture plate for filing, loosen the captive quarter-turn wing-head screw securing the aperture plate to the slider bracket. Allow the hinged portion of the slider bracket to drop, and withdraw the aperture plate from the trap. File the aperture plates to size the picture to the screen and/or masking. NOTE: When projecting a white light while filing apertures, close the lamphouse douser *frequently* to allow the lens to cool.

DO NOT attempt to correct “keystoning” by shimming the turret or offsetting the position of the lenses. The lenses must be positioned on optical center to project a satisfactory image.

THREADING

THREADING THE PROJECTOR correctly before each presentation is one of the operator's most important duties. Careful attention during this operation pays off in improved performances and long print life.

THE CENTURY "JJ" FILM GATE DESIGN varies between standard, single-lens and turret-equipped machines. The single-lens film gate features a large, chromed knob which is rotated in a clockwise direction until it locks in the threading position. After threading through the film gate, pressing the knob inward closes the gate against the trap.

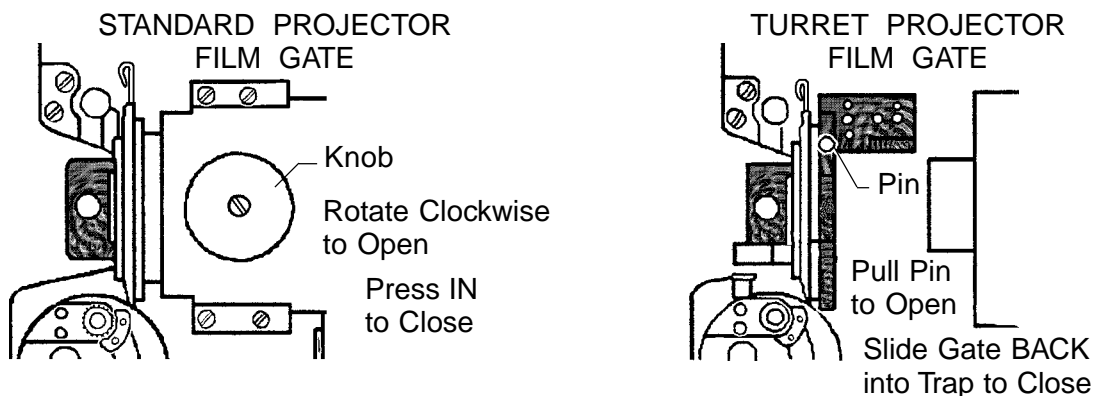

TURRET PROJECTORS utilize a film gate mounted to a linear bearing which slides, on the horizontal plane, into or away from the film trap. A knurled-head release pin secures the gate in its closed position. To open the gate, pull the head of the release pin, and allow the gate to slide forward (away from the trap). After threading, press the gate into the trap until the release pin locks and secures the position of the film gate.

IT IS HIGHLY RECOMMENDED to clean the gate and trap prior to each threading operation. Open the film gate (as instructed above) and remove the gate pressure pad. To remove the pressure pad from the Standard gate, grasp the pressure pad at the bottom, and swivel the pad upward. Lift it from the pivot, and remove. The Turret gate pressure pad is secured to the gate casting by (2) pins retained by spring-loaded catches, and can be pulled from the gate casting. Use a clean, dry cloth to wipe down all film-bearing surfaces of the gate and trap. After cleaning, replace the pressure pad assembly (note "TOP" marked inside runners).

PICTURE FRAMING on the Century projector is achieved by raising or lowering the intermittent movement, thus raising or lowering the film frame on the picture aperture. Rotation of the FRAME knob on the front of the projector causes the intermittent to travel up or down. Observe the upper and lower limits of intermittent travel, and position the intermittent at the center of its travel. This will insure adequate movement up or down to correct accidental misframes. Always "center" the intermittent in this manner before threading.

THREADING (continued)

ROTATE THE MOTOR FLYWHEEL and observe the intermittent sprocket. Unlike the continuous rotation of the feed and holdback sprockets, the intermittent sprocket rotates in steps. The outer sprocket teeth, for 70mm film, will advance (5) perforations per step, while the inner 35mm teeth will advance (4) perforations. Turn the motor flywheel until the intermittent sprocket *stops* after completing one of these steps.

PAD ROLLER ASSEMBLIES on the Century “JJ” are fitted with both the 35mm and 70mm pad rollers. The handle of the upper pad roller assembly is stamped with numbers, the orientation of which indicate its application:

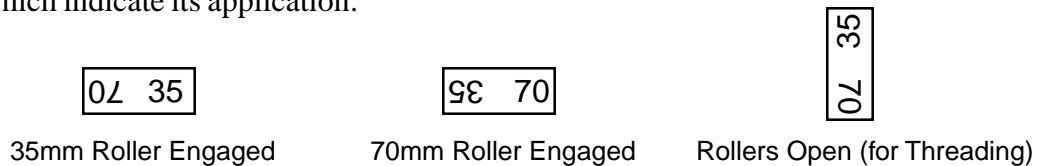

THE NUMBER “35” or “70,” when reading correctly on the horizontal plane, as shown above, indicates that the 35mm or 70mm pad roller is engaging the appropriate sprocket. A similar number is stamped on the *top* and *bottom* of the lower pad roller handle; the number visible on the top of the handle, when viewed from above, indicates the pad roller selected.

OPEN THE FILM GATE. Open the upper and lower pad roller assemblies. Open the intermittent sprocket shoes. Turn on the framing lamp (toggle switch on top of projector).

THREAD THE FILM under the upper feed sprocket, over the upper pad roller, and through the film gate. Engage the film on the intermittent sprocket while viewing the framing aperture (the turret may be opened to improve the view of the framing aperture). Center a frame of the protection leader in the framing aperture, and close the intermittent sprocket shoes. A correctly framed image in the framing aperture insures correct frame positioning on the picture aperture.

CLOSE THE FILM GATE by pressing the knob of the standard projector, or sliding the gate of the turret projector into the trap until the release pin latches. As required, swing the turret closed and make certain that the latch engages.

ENGAGE THE FILM with the upper feed sprocket, form a two-finger loop, and close the upper pad roller. *Check for correct format (35/70);* closing the 35mm pad roller onto 70mm film will severely damage the print.

THREAD BELOW the idler roller and lower pad roller assembly and over the lower holdback sprocket. Engage the film with the holdback sprocket, form a two-finger loop, and close the lower pad roller, checking again for the correct 35/70 format setting.

THREADING (continued)

TURN THE MECHANISM by hand to advance a few frames of film. Do not turn the projector motor on and off to check threading. If the film is not threaded properly, film damage may occur. Run fingers over each sprocket to insure that the sprocket teeth are centered in the film perforations, and the film is centered between the pad roller flanges. Check again the position of the film in the framing aperture (open the turret if required). Use the framing knob to correct misframes. Make certain the turret is securely closed and latched.

THREAD THE SOUNDHEAD AND PENTHOUSE as detailed on the following threading diagrams. Take up any slack between the projector and the film transport; a slight degree of film tension is required above the magnetic penthouse and below the optical soundhead. This prevents the film from snapping upon motor start.

THREADING DIAGRAM

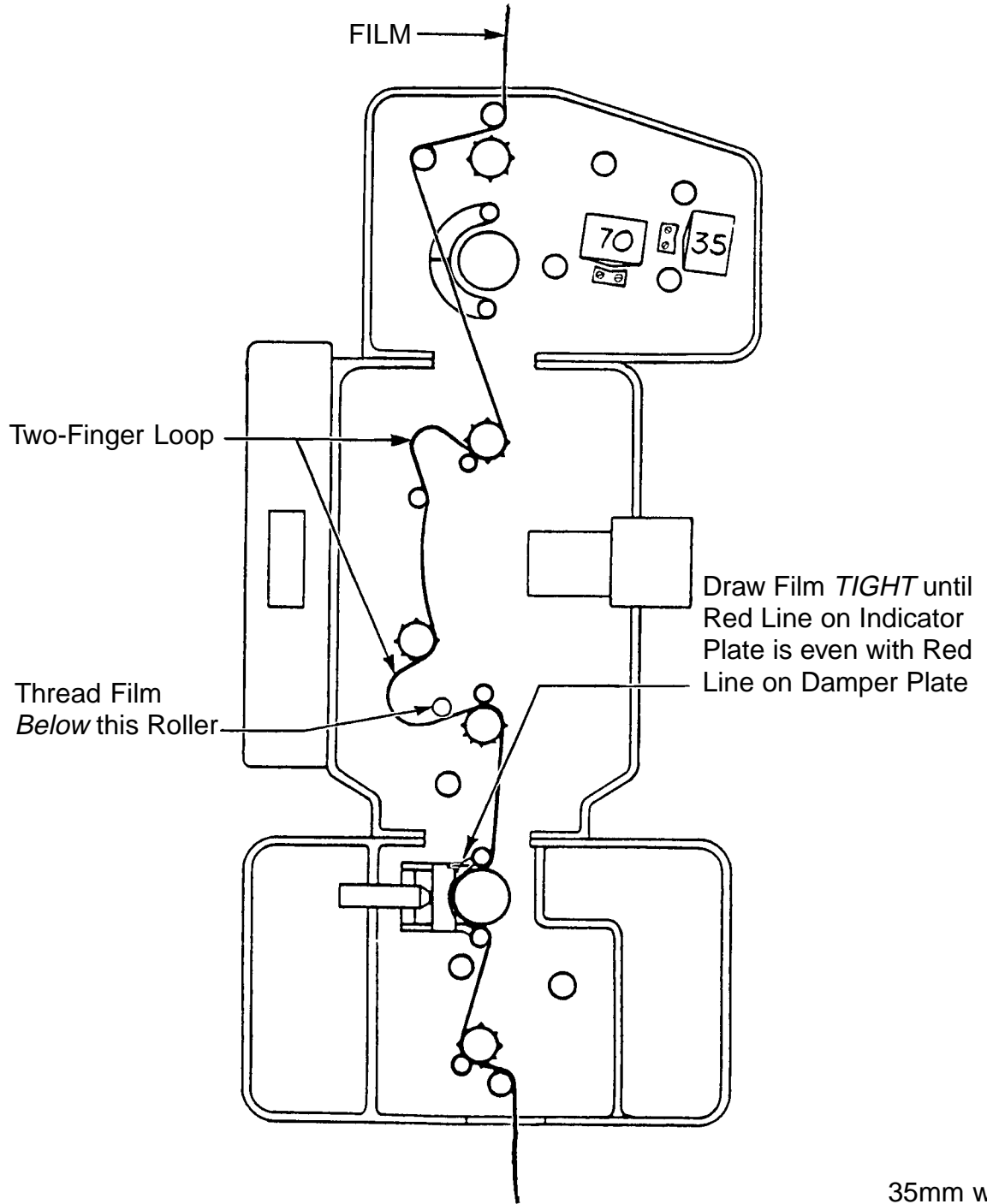

35mm with
Optical Sound

THREADING DIAGRAM

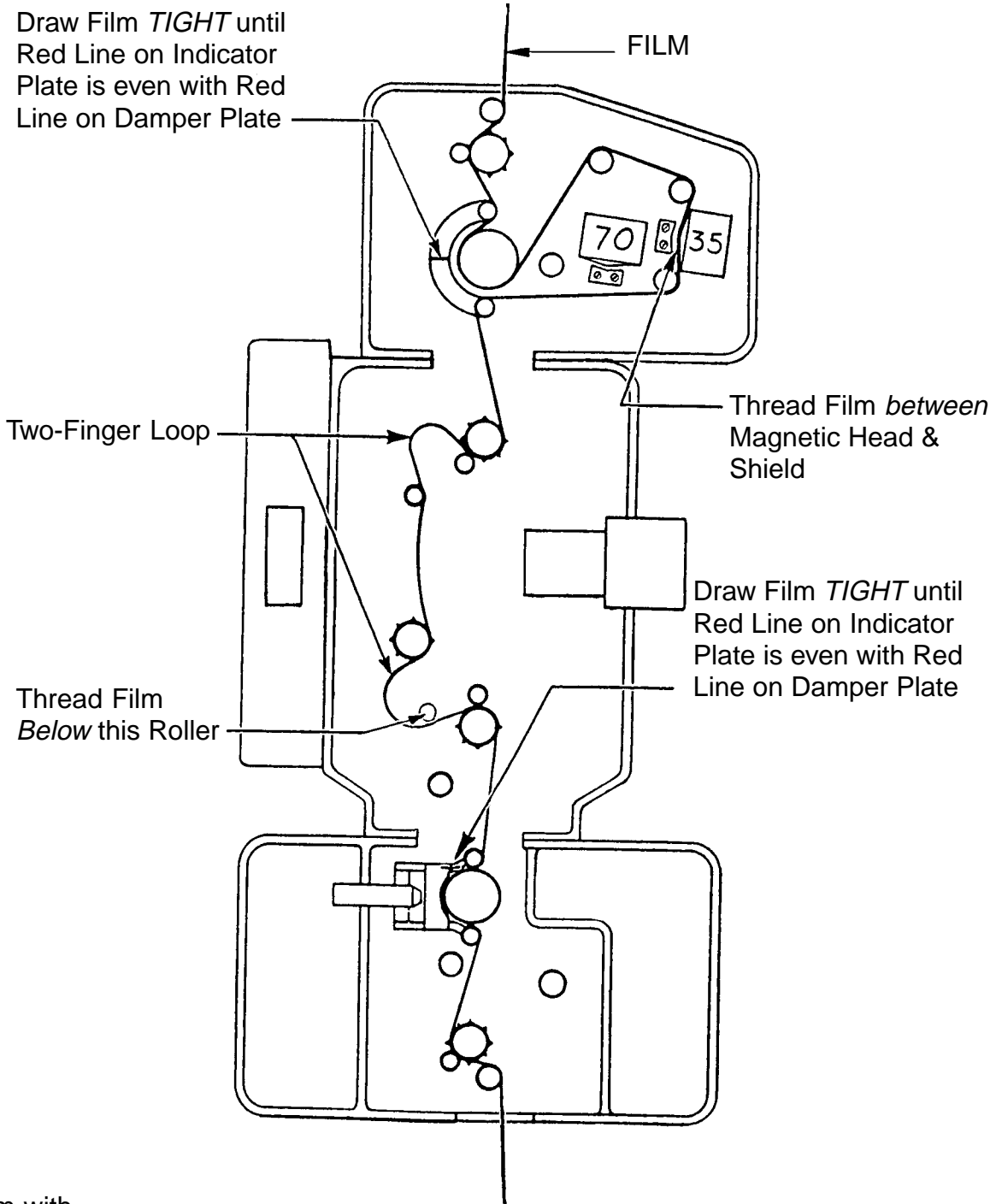

35mm with
Magnetic Sound

THREADING DIAGRAM

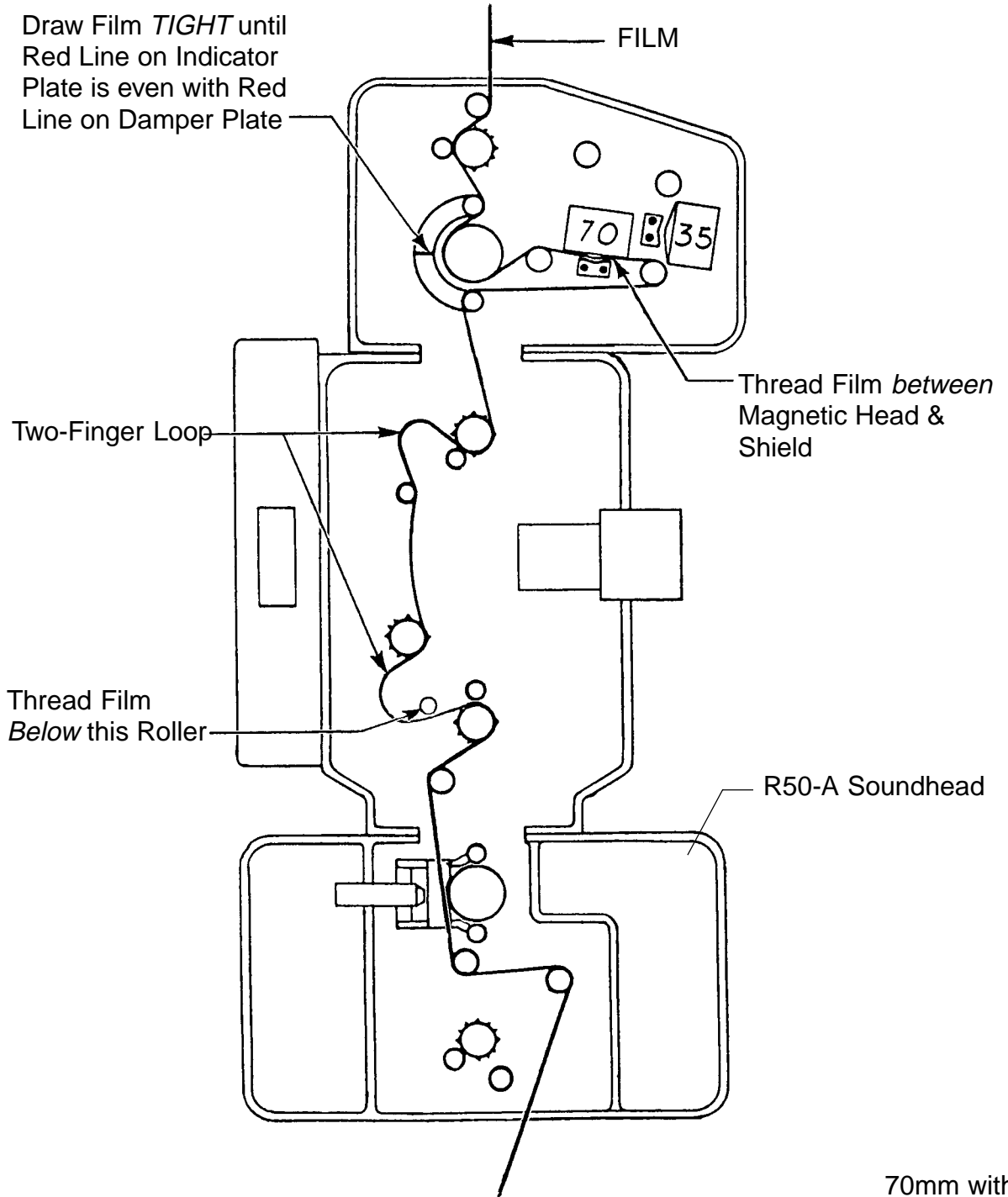

70mm with
Magnetic Sound

THREADING DIAGRAM

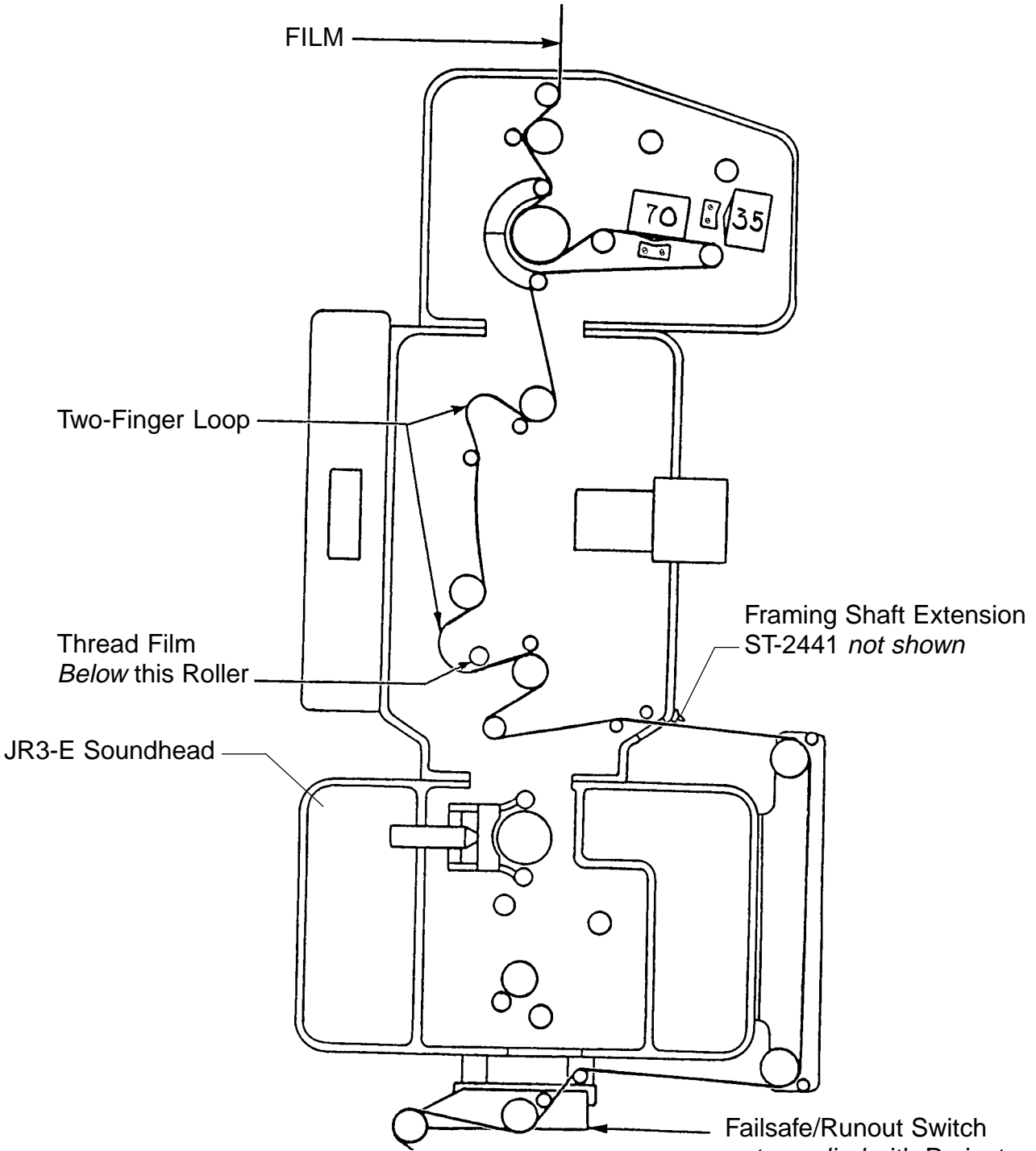

70mm with Magnetic Sound,
using Soundhead Bypass Rollers

35/70mm CONVERSION

TO AID in rapid format conversion, those components to be interchanged have been designed to be removed and installed without use of hand tools. Pad roller assemblies include both 35 and 70mm rollers, and do not require mechanical interchange.

FILM TRAP

Rotate the framing knob and position the intermittent movement at mid-position (halfway through its up-and-down travel). Loosen the thumbscrew, and pull the film trap out of the film compartment. Align the milled dovetail of the replacement trap to the trap support gib, and slide the replacement trap into the film compartment. Tighten the thumbscrew.

FILM GATE (Standard Model, less Turret)

Rotate the upper pad roller arm control handle so the “35” is at the 11:00 o’clock position (as shown). Open the film gate by rotating the knob clockwise until it locks open. Grasp the bottom of the gate pressure pad plate, and swing upward. Do not strike the pad rollers above the gate. Release the pressure pad studs from the upper and lower supports, and remove from the film compartment. Leaving the pad roller arm control handle in the position shown, install the replacement gate pressure pad assembly, engaging first the upper stud, and swinging the lower stud into place.

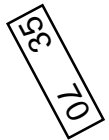

FILM GATE (Turret Model)

Rotate the upper pad roller arm control handle to the position illustrated above (“35” at 11:00 o’clock). Open the film gate by pulling the gate release pin and sliding the gate away from the film trap. Grasp the gate pressure pad plate at the top and the bottom, and pull it out of its spring-loaded recesses. Align the (2) studs of the replacement gate pressure pad, and push it into the recesses.

INTERMITTENT SPROCKET SHOE PAD ASSEMBLY

Rotate the framing knob and position the intermittent movement at mid-position (halfway through its up-and-down travel). Open the lower pad roller arm assembly. Open the intermittent sprocket shoe pad arm, and pull the arm assembly straight out from the film compartment. Exercise care not to strike the teeth of the intermittent sprocket.

Make certain the replacement intermittent shoe pad arm assembly is in its OPEN position, and align the slot in the mounting stud directly up and down (90°). Press the replacement arm assembly into the intermittent cover; rotate the arm assembly back and forth until the spring and plunger unit secures the stud. Open and close the arm assembly and check the alignment of the shoes to the sprocket face.

INITIAL OPERATION

CLEAN ALL FILM-BEARING SURFACES PRIOR TO THREADING. Check all sprocket teeth for hooks or burrs; replace if required. Keep all pad rollers clean and operating freely. Make certain the turret (if so equipped) is set to the correct lens and aperture for the desired screen format. FLAT format is generally used for initial set-up of the projection system.

THE FILM TRAP TENSION KNOB is located at the top of the film trap. Rotate the knob to position the white line pointing straight up (12:00 o'clock). This position indicates minimum trap tension. Thread film into the projector, ignite the lamp, open the douser, and project a picture to the screen. Use of RP-40 test film is highly desirable for this stage of machine set-up. This test film may be purchased directly from the Society of Motion Picture and Television Engineers:

SMPTE Test Film Department
595 West Hartsdale Avenue
White Plains, New York 10607

Order: 35 PA-50 (50 ft.)
or 35 PA-200 (200 ft.)

INSTALL THE LENS(ES) and set focus as detailed in the preceding INSTALLATION section. File the apertures to fit screen masking. Position and tilt the pedestal or console as required to center the picture on the screen.

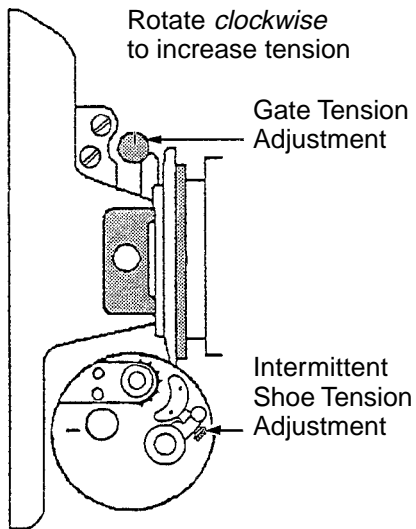

IF THE PROJECTED PICTURE is unsteady, rotate the film trap tension knob gradually in a clockwise direction, while the film is running. To remove picture "jump," adjust the intermittent shoe tension. Always adjust for the minimum tension required to project a steady picture. Excessive tension not only increases wear on parts, but in extreme cases may cause torn film perforations and contribute to print wear and breakage.

CHECK THE PROJECTED PICTURE for flicker or travel ghost. "Travel Ghost" is the term commonly applied to vertical streaking of lighter areas against a darker area, and is particularly noticeable during opening or closing titles and credits. This indicates that the shutter is out of time. The shutter is carefully timed at the factory, but the setting may be disturbed by vibration in shipping. To reset the shutter, see "Shutter Timing" in the ADJUSTMENTS AND REPLACEMENTS section following.

INITIAL OPERATION (continued)

THE LENS MOUNT ECCENTRIC on the standard (non-turret) machine must be set for the desired format (35mm or 70mm). Loosen the clamping nut of the 35/70 selection knob at the tip of the lens mount on the front of the projector. Turn the knob either clockwise or counterclockwise until the proper designation (35/70) is shown. The knob rests in detent stops when correctly positioned. Tighten the clamping nut to secure the position.

LENS TURRET (Optional)

THE ROTATION TRAVEL of the optional lens turret is limited by the indexing stop pin mounted to the outer ring of the turret. The automated turret includes a solenoid which pulls the pin when the turret is in motion. Two coil expansion springs seat the pin when the turret is at rest. When first energized, the autoturret will automatically index to FLAT mode, if not already in FLAT. The photo switch on the turret ring will “read” the cueing flag and position the correct aperture plate opening (silver = FLAT, black = SCOPE, black outer edge = third lens).

REPEAT THE PROCEDURE using the SCOPE lens and aperture. Observe the position of the picture on the screen. If the SCOPE picture is higher or lower than the FLAT picture, or if the image shifts to the left or right, it is necessary to adjust the position of one or both of the lens barrels. See the ADJUSTMENTS AND REPLACEMENTS section following (LENS TURRET, Steps 3 and 4) for detailed instructions.

IN THE EVENT of a turret motor failure, the automatic turret can be operated manually until a replacement motor is obtained. A lever on the solenoid housing allows withdrawing the index stop pin manually. Do not index the turret by grasping the focus knobs; lens focus will be altered. The aperture plate can be pushed in or pulled out manually to set the correct format. It is advisable to de-energize the turret control module until the replacement motor is installed.

MAINTENANCE

WITH PROPER MAINTENANCE, the Century Projector will deliver many years of trouble-free operation. The following is the recommended maintenance schedule for the Century Projector. Contact your authorized Strong International Dealer for the required lubricants and other supplies.

DAILY:

1. Before starting the projector, check the intermittent oil level. When the projector is not running, the oil level should be at, but not higher than the red line on the intermittent case. Add Century Projector Oil as required.
2. Open the film gate and remove the gate pressure pad assembly. Using a soft, dry cloth, wipe down all film-bearing surfaces of the gate and trap. Replace the pressure pad assembly (NOTE: "TOP" marked on inside of plate).
3. Clean the sprockets and rollers with a soft brush. A clean, used toothbrush is ideal for this purpose.
4. Wipe out any dust, film residue, or oil accumulation.

WEEKLY:

1. Check the setting of the pad rollers. Allow two film thicknesses of clearance between the pad rollers and the faces of the film sprockets.
2. Open the gear compartment. Brush a little Century Gear Lubricant (Part No. TU-0380) on the surfaces of the gears. Wipe off excess build-up.

MONTHLY:

1. Add a drop or two of Century Projector Oil to the starwheel shaft outer bushing. The oil hole is in the intermittent outboard arm adjacent to the intermittent sprocket.
2. Add a few drops of Century Projector Oil to the oil cups above the upper and lower sprocket shafts in the film compartment.

EVERY THREE MONTHS:

1. Inspect the sprocket teeth for burrs or hooks. For normal (forward-only) operation, a "hooked" sprocket may be reversed on its shaft and re-used.

MAINTENANCE (continued)

EVERY THREE MONTHS (continued)

2. Check the pad rollers for free movement. Rollers should show even wear with no flat spots; roller flanges should be rounded with no cuts. Replace if required.
3. Check the grease around the main drive shaft. If it is dirty or dark in color, clean it out and replace with new Century Gear Lubricant (TU-0380). Make certain that the inner surfaces of the gear teeth are lubricated.
4. Dismount and carefully inspect the film trap. The film trap shoes (straps) are subject to periodic replacement and must be free from scratches, burrs, and excessive wear. The lateral guide rollers at the top of the trap must be clean and rotating freely. The studio guides should be positioned to accept all conditions of film.

YEARLY:

1. Drain the intermittent oil. When removing the drain screw, note the sequence of installation of the (3) washers. Replace the drain screw and all (3) washers in the correct sequence illustrated (fibre washer against intermittent case) to prevent oil seepage. Replace the oil using only genuine Century Projector Oil; **DO NOT OVERFILL**.
2. It is a good mechanical practice to periodically check the equipment and make certain that all retaining and fastening screws and nuts, collars, gears, pulleys, couplings, etc. are tight and have not worked loose in the course of normal operation.
3. Check fittings and hoses on water cooled systems. Replace coolant if required (4:1 ratio of distilled water to all-weather antifreeze).

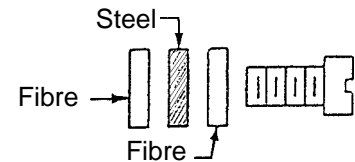

LIGHT LUBRICATION of the gate pressure pad and the trap shoes is permitted after cleaning for smoother and quieter operation. Use a commercially available film lubricant such as XeKote® or equivalent. **DO NOT OVERLUBRICATE**. Excessive lubrication will attract and hold dust and film residue.

FIGURE 3

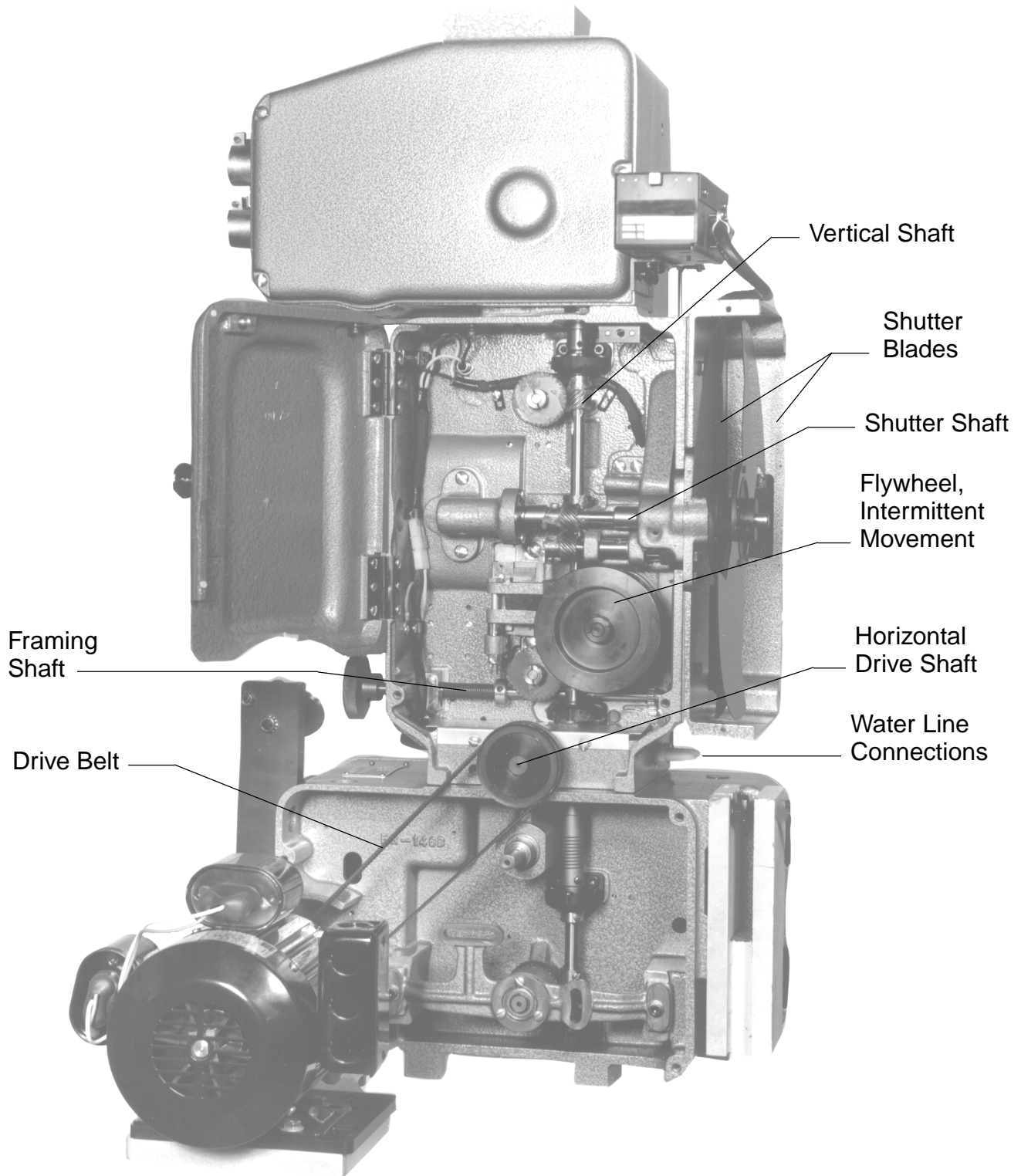

ADJUSTMENTS AND REPLACEMENTS

REFER TO THIS SECTION in conjunction with following the routines in the MAINTENANCE section. Conscientious service and preventative maintenance of the Century Projector will insure many years of excellent performance.

ADJUSTMENTS are quickly accomplished, and replacements performed, since all units and components are readily removed. Adjustments and replacements described below may be performed by qualified projection booth personnel. Any elements of maintenance and service not detailed below should be referred to an authorized Strong International Dealer.

INTERMITTENT SPROCKET SHOE REPLACEMENT

1. Open the intermittent shoe assembly and the lower pad roller arm assembly. Withdraw the intermittent shoe assembly from the film compartment. Replace worn components.
2. Check the coil spring for correct tension. To remove the coil spring, remove the small slotted round head screw which serves as a stop for the knurled tension adjusting nut. Unscrew the knurled nut and remove the spring. Stretch or replace the spring as required; reassemble.
3. When replacing the intermittent shoe assembly, insert the arm assembly with the slot in the stud straight up-and-down. Press and slightly twist the arm assembly to allow the spring-loaded plunger unit locks into place.
4. Open and close the intermittent shoe arm several times, and check the alignment of the replacement shoes to the face of the intermittent sprocket.

FILM GATE PRESSURE PAD REMOVAL

1. Remove the pressure pad assembly from the film compartment of the standard "JJ" (non-turret) by opening the film gate and grasping the bottom of the pressure pad plate, and swinging the plate upward and off its upper pivot. Open the film gate of the turret-equipped projector, and pull the pressure pad plate straight back (toward the trap) until the spring plungers release the plate studs.
2. When replacing, note the top of the pressure pad runner plate is marked "TOP."

FILM TRAP REMOVAL

1. If removing the film trap from a water-cooled mechanism, it is not necessary to disconnect the water lines. Water cells are located in the trap support gib assembly.
2. Open the film gate and loosen the large knurled-head screw located on the trap behind the picture aperture. This is a "captive" screw, and need not be completely removed.

ADJUSTMENTS & REPLACEMENTS (continued)

FILM TRAP REMOVAL (continued)

3. When the knurled-head screw is disengaged from the trap support gib, withdraw the complete film trap from the film compartment. The aperture changer used with turret machines is disconnected by removing a single from its mating receptacle.
4. Inspect the milled dovetail of the replacement trap. Make certain that it is free from dirt and/or film residue. Clean the outer surface of the trap mounting gib.
5. When replacing the film trap, engage the dovetail of the trap with the dovetail of the trap support gib. Slide the trap all the way inboard until the machined surfaces of the trap and the support gib mate firmly together. Start the knurled screw slowly by hand to prevent crossthreading, and then securely tighten. Plug in the aperture changer (if so equipped).

FILM TRAP PRESSURE STRAP REPLACEMENT

1. Always replace the Pressure Straps in *matched pairs*. Rotate the film tension knob to its minimum tension setting (white line at 12:00 o'clock). Open the film gate and remove the film trap as instructed above.
2. Remove the (4) strap mounting screws from the trap casting; (2) on top, (2) on bottom. NOTE: washers are used under the top (2) screws only. Install the replacement straps and tighten the (4) screws.

ALIGNMENT OF LATERAL GUIDE ROLLERS & STUDIO GUIDES

1. Open the film gate and remove the pressure pad. Dismount the intermittent shoe assembly.
2. The pivots of the lateral guide rollers are held by (2) hex head set screws at the top of the trap behind the framing aperture. Loosen these (2) set screws.
3. Thread a length of film between the upper feed sprocket and the intermittent sprocket. Draw the film taut between the studio guides until it lays flat against the trap shoes (pressure straps).
4. When properly assembled, the outboard lateral guide roller is fixed, while the inboard lateral guide roller is spring-loaded and moves horizontally. Bring the fixed (outboard) guide roller into contact with the film and tighten the hex head pivot set screws.
5. Make certain that the inner surfaces of the studio guides are in contact with the outer edges of the film. This allows the proper clearance for the passage of film.
6. Replace the gate pressure pad and the intermittent sprocket shoe assembly.

FILM GATE SUPPORT REMOVAL

1. Rotate the gate release knob clockwise to open the film gate. Dismount the film trap as instructed above. Press the gate release knob to close the film gate

ADJUSTMENTS & REPLACEMENTS (continued)

FILM GATE SUPPORT REMOVAL (continued)

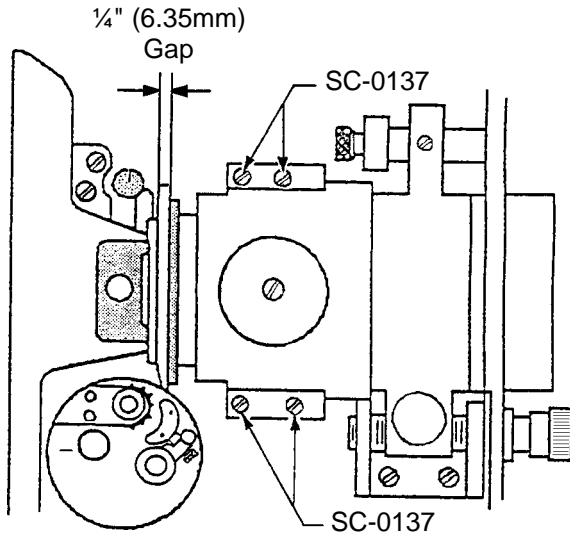

2. Remove the (4) slot head gate support mounting screws (SC-0137) securing the support casting to the main frame. Pull the support casting straight out of the film compartment.
3. To replace the gate support, set the SC-0137 slot head mounting screws through the holes of the support casting and into the four mating tapped holes in the projector main frame. Attach, but do not tighten the screws.
4. Replace the film trap. Set the distance between the trap and the gate by placing a $\frac{1}{4}$ " (6mm) allen wrench or similar spacer between the trap studio guides and the gate pressure pad plate, with the gate in the CLOSED position. Set the gate parallel to the trap studio guides. Tighten the (4) SC-0137 screws.

FILM GATE SUPPORT REMOVAL (Turret Models)

1. Open the film gate and remove the film trap. Close the film gate.
2. Remove the gate release spring at the bottom of the sliding ball bearing assembly.
3. Remove the (2) socket head gate support mounting screws recessed inside the bearing assembly and pull the support assembly straight out of the film compartment.
4. To replace the gate support casting, set the (2) low-head socket screws through the recess of the bearing assembly and into the mounting block of the bearing assembly.
5. Replace the film trap. Set the distance between the trap and the gate by placing a $\frac{1}{4}$ " allen wrench or similar spacer between the trap studio guides and the gate pressure pad plate (gate in CLOSED position). Position the gate to be parallel with the trap studio guides. Tighten the (2) mounting screws.
6. Re-install the gate release spring and the pressure pad assembly as shown

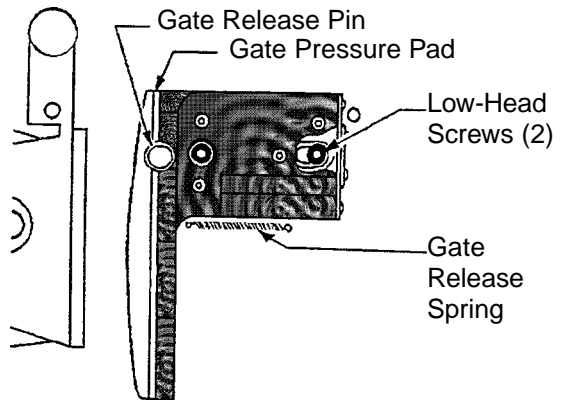

ADJUSTMENTS & REPLACEMENTS (continued)

FILM SPROCKET REPLACEMENT

1. Open the pad roller. Remove the sprocket retaining screw from the center of the sprocket. Pull the sprocket from its shaft.
2. To install the replacement sprocket, open the gear compartment door and press the fibre sprocket shaft driven gear firmly against its bushing. From the film compartment, slide the replacement sprocket onto the sprocket shaft and press it against its bushing to remove end play. Replace and tighten the sprocket retaining screw.

PAD ROLLER REPLACEMENT & SERVICING (Lower Holdback Sprocket)

1. The pad roller arm assembly can be dismantled as a unit by loosening the 1/4-20 retaining set screw securing the arm assembly to the main frame. Set the pad roller arm to the "70mm" position, and close the pad roller. Loosen the set screw using a 90° 1/8" allen wrench and withdraw the pad roller assembly from the film compartment.
2. To replace a pad roller, dismount the inboard roller retainer plate by removing the binding head screws. Install the replacement pad roller on the shaft and remount the retaining plate.
3. Set the pad roller arm in its CLOSED position and return the pad roller assembly to the film compartment. Rotate the pad roller assembly and rest the tip of the hex head stop screw against the stop pin. Retighten the retaining set screw.
4. Open and close the pad roller to check for correct operation; make certain the roller flanges are not binding against the 70mm sprocket. Check the setting of the hex head stop screw; allow a (2) film thickness clearance between the pad roller and the face of the sprocket.

PAD ROLLER REPLACEMENT & SERVICING (Upper Feed Sprocket)

1. The 35/70 selector handle is secured to the pad roller arm using (2) set screws accessible at the ends of the handle. Loosen these set screw and remove the handle to expose the roller shafts. Replace pad roller as required and replace the handle, checking for correct 35/70 orientation.
2. To set the (2) film thickness clearance between the pad roller and the sprocket face, loosen the (3) socket head screws securing the upper pad roller arm to the main frame, and adjust using the slots provided. Secure the (3) socket head screws after setting the correct clearance.

FIRE SHUTTER SETTING (Optional Accessory C1-G-22)

1. To reset the height of the (optional) fire shutter, open the gear compartment door and loosen the set screw in the upper governor weight holder. See Assembly C1-G-22 on the "Vertical Shaft" drawing following. Loosening the set screw will allow both the governor and the fire shutter to be raised or lowered as a unit.

ADJUSTMENTS & REPLACEMENTS (continued)

FIRE SHUTTER SETTING (continued)

2. Set to the correct height. If the shutter is too low, it will intrude into the light beam; if too high, it will strike the inner surface of the film compartment light shield.
3. When the proper height of the fire shutter has been set, tighten the upper governor weight set screw. Close the gear compartment door.

SHUTTER SHAFT REMOVAL

1. Remove the rounded portion of the shutter guard. Open the gear compartment.
2. Remove the (2) slot head screws securing the right-angle bearing bracket BR-0186 to the main frame. Remove the (4) socket head screws mounting rear bearing bracket BR-0015 to the back of the main frame. Remove the shutter shaft assembly as a unit.

VERTICAL SHAFT REMOVAL & SERVICING

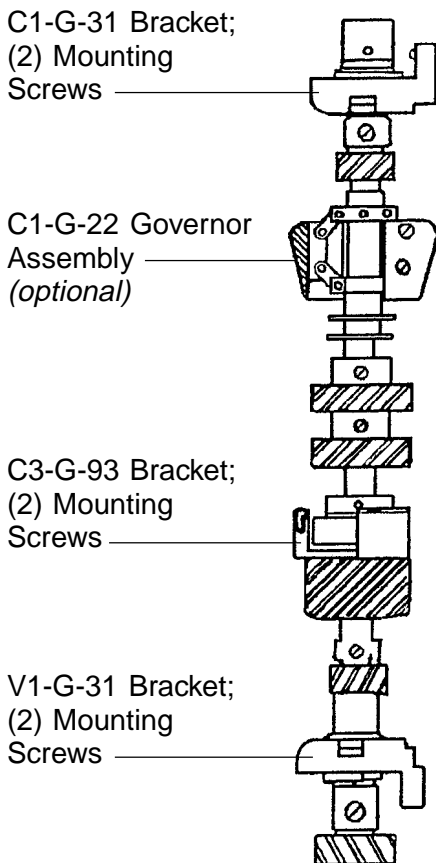

1. Remove the rounded portion of the shutter guard, open the gear compartment, and dismount the shutter shaft assembly.
2. Dismount the lower drive cover. Remove the (4) screws holding the (2) ball bearing brackets (upper and lower; see illustration).
3. Remove the (2) socket head screws connecting the intermittent drive gear bracket (ref. C3-G-93) to the shutter adjustment bracket. Release the drive gear bracket from its position.
4. Using both hands, grasp the upper and lower bearing brackets (C1-G-31) and remove the entire vertical shaft assembly from the gear compartment.
5. To disassemble the vertical shaft, remove the collar nut on the top of the shaft by loosening its (2) set screws and unscrewing it from the shaft. Dismount the bottom gear from the shaft by removing its retaining screw.
NOTICE: Keep all components in sequence for reassembly. Steel washers are always placed against the face of all ball bearings.
6. Upon reassembly, the upper collar nut should be threaded down on the shaft to rest gently against the upper washer retainer. This will take out all end play between the ball bearings and the collar. When so positioned, tighten the (2) collar set screws.

ADJUSTMENTS & REPLACEMENTS (continued)

VERTICAL SHAFT REMOVAL & SERVICING (continued)

7. To return the vertical shaft assembly to the mechanism, perform the above procedures 1 - 4 in reverse order. Before tightening down any mounting screws, make certain all gears mesh with a minimum of backlash, yet free of drag.
8. Reset the shutter timing before replacing the shutter guard. Refer to the instructions in the following section.

SHUTTER TIMING

1. Remove the rounded portion of the shutter guard. Remove the sight box glass from the operator's side by lightly pressing on the glass and sliding it upwards. With the glass removed, the indicator bar is visible in the sight box.
2. Rotate the shutter adjustment knob (if so equipped) to its center position. This knob exists on early model "JJ" projectors only.
3. Rotate the motor flywheel to "inch" the mechanism. With the intermittent movement at rest (locked stage), position a stationary object next to a single inner (35mm) tooth on the intermittent sprocket. Slowly rotate the flywheel and allow a (2) tooth advance.
4. Both shutter blades should be aligned and in the fully closed position (centered over the picture aperture). If not, proceed with Step 5.
5. Loosen the (2) screws in the hub of each shutter blade. Hold the intermittent flywheel in a stationary position to prevent the mechanism from moving, and rotate the shutter blades to the fully CLOSED position. A notch in the edges of the master shutter blades will align with the indicator bar in the sight box when the shutters are fully closed.
6. Firmly tighten the (2) screws in the hub of each shutter. Recheck the shutter timing by rotating the motor flywheel for another (2) tooth advance and verifying the alignment of the shutter notches to the indicator bar.
7. Replace the sight box glass and the shutter guard.

MAIN (HORIZONTAL) DRIVE SHAFT

1. Open the film compartment. Remove the ball bearing retainer below the lower sprocket by loosening the set screw to the right of the retainer. The ball bearing retainer has an 8-32 hole threaded in its center. By threading an 8-32 screw into this hole, the head of the screw can be used to pull the retainer straight out of the main frame.
2. Remove the (2) set screws (SC-0902) from the drive gear. The set screws are 90° apart.
3. Remove the (2) screws holding the seal on the gear side.
4. From the film compartment, using a brass bar and a hammer, tap the horizontal shaft until it works free. Withdraw it from the gear compartment side, leaving the drive gear in place.

ADJUSTMENTS & REPLACEMENTS (continued)

MAIN (HORIZONTAL) DRIVE SHAFT (continued)

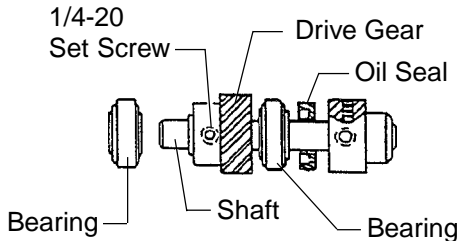

5. Remove the drive gear from the grease bath.
6. To install a replacement drive shaft, first position the drive gear in the grease bath. Observe the position of the (2) set screws.
7. Slide the shaft through the outboard bearing and into the gear. Align the (2) holes in the shaft (90° apart) with the (2) set screws in the gear.
8. When the gear set screws are aligned to the holes in the drive shaft, slide the shaft into the inboard bearing. Tighten the (2) SC-0902 set screws. The points of the set screws will engage the holes in the drive shaft when correctly aligned. Replace the (2) screws against the seal.
9. Seat the ball bearing retainer on the film compartment side to remove any end play. When seated firmly, tighten the retainer set screw.
10. Check the condition of the grease in the grease bath. If the grease is discolored or contaminated with dirt or dust, clean it out and replace with fresh TU-0380 Century Gear Lubricant. Grease the inner surfaces of the gear teeth.

FRAMING/THREADING LAMP REPLACEMENT

1. Unscrew the glass protector shield and remove the threading light bulb from its socket.
2. Replace the bulb with a 12 volt, 6 watt candelabra-base bulb (Century Part No. LP-0122). Replace the glass protector shield over the bulb.
3. Dismount the light shield casting surrounding the film trap to expose the framing lamp. Replace the framing lamp using LP-0122 bulb. Replace the light shield casting.

INTERMITTENT MOVEMENT

Each Century Intermittent Movement utilizes components machined to near-zero tolerances and are assembled by trained technicians using special fixtures and tools. Many critical adjustments are difficult to perform in the field, and in some instances noted below, it is recommended to return the movement to the factory for overhaul by qualified personnel. Contact your authorized Strong International Dealer for a **Return Authorization** and shipping information. Factory rebuilt intermittent movements are available under a Repair/Exchange program.

INTERMITTENT MOVEMENT REMOVAL

1. Open the gear compartment (off-operator side door) and dismount the intermittent flywheel.
2. In the film compartment, close the lower pad roller and frame the intermittent all the way DOWN. Dismount the gate pressure pad, the film trap, and the light shield.
3. Loosen, but do not remove, the (4) SC-0106 mounting screws. Rotate the intermittent movement clockwise approximately one-eighth (1/8) of a turn until the cutouts in the intermittent case align with the heads of the SC-0106 screws.
4. Pull the intermittent movement out of the film compartment, taking care not to strike the intermittent sprocket against any object which might damage its teeth.

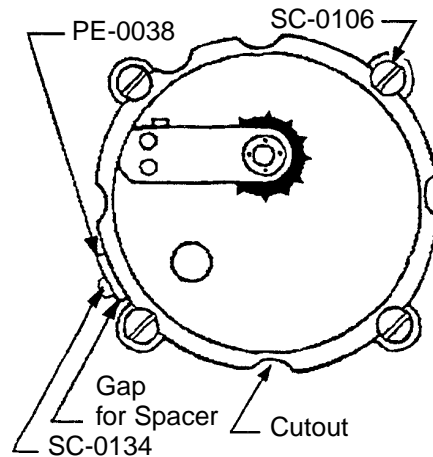

INTERMITTENT MOVEMENT INSTALLATION

1. Dismount the flywheel (if supplied) from the replacement movement. Loosen the SC-0134 intermittent stop screw.
2. Insert the intermittent movement into the film compartment. Align the cutouts in the intermittent case with the heads of the (4) SC-0106 mounting screws.
3. Slide the intermittent into its opening and rotate counterclockwise until the driven gear of the intermittent meshes with its drive gear on the vertical shaft. Turn the movement until the gears mesh with no backlash or excessive play.
4. Tighten any (2) of the SC-0106 mounting screws. Slide the PE-0038 stop plate firmly against its stop, and tighten the SC-0134 screw.
5. Loosen the (2) SC-0106 screws previously tightened. Rotate the movement clockwise to allow a 3/64" (1.19mm) gap between the stop plate and its stop.
6. Insert a 3/64" (.0468 inch; 1.19mm) spacer (i.e. a U.S. dime) between the stop plate and its stop. Tighten all (4) SC-0106 mounting screws. This allows the slight (.003 inch) degree of backlash required between the vertical shaft drive gear and the intermittent driven gear.

ADJUSTMENTS & REPLACEMENTS (continued)

INTERMITTENT MOVEMENT INSTALLATION (continued)

7. Loosen the SC-0134 stop plate screw and remove the above spacer. Press the PE-0038 stop plate against its stop and tighten the SC-0134 screw.
8. Lubricate the gears using TU-0380 Gear Lubricant. Install the intermittent flywheel. Fill the intermittent movement to the oil level line with Century Projector Oil. **DO NOT OVERFILL.**
9. **TIME THE SHUTTER** following the instructions preceding in the ADJUSTMENTS AND REPLACEMENTS section.

INTERMITTENT SPROCKET REPLACEMENT

1. Remove the intermittent movement per preceding instructions. Rotate GR-0007 gear until the intermittent sprocket comes to its locked position.
2. Remove the SP-1326 film stripper and the SC-1322 screw holding the SK-1480 intermittent sprocket to its shaft.
3. Loosen the (2) SC-1235 set screws in the CL-0624 collar, and remove the collar.
4. Remove the (2) SC-1190 socket head screws mounting the H1-BB-34 outboard bearing arm. Carefully remove the bearing arm.

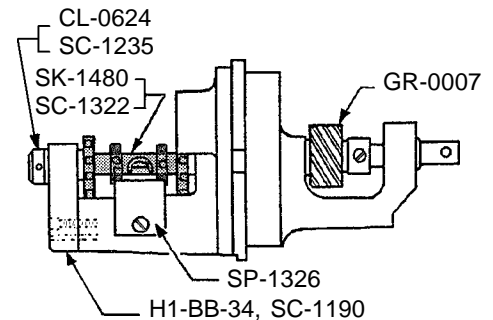

NOTE: The outboard bearing arm is factory-positioned by (2) dowel pins. If the bearing arm does not slide off freely, tap gently on the inner side of the arm, taking care not to bend the starwheel shaft.

5. Slide the SK-1480 sprocket off the starwheel shaft. Slide the replacement sprocket onto the shaft without applying force.
6. Align the mounting hole in the sprocket to the hole in the starwheel shaft. Insert the SC-1322 screw and add the nut; do not tighten.
7. Replace the H1-BB-34 outboard bearing arm, aligning to the dowel pins, and secure with the (2) SC-1190 socket head screws.
8. Thread the sprocket clamping nut onto the SC-1322 screw until two sides of the hexagon seat in the cutouts on the sprocket hub. This will anchor the nut for tightening.
9. Replace the CL-0624 collar on the end of the starwheel shaft. Press the collar against the outer surface of the starwheel bushing, while pulling the sprocket toward the collar. When the end play has been thus removed, tighten the (2) SC-0579 collar set screws. Replace the SP-1326 film stripper.
10. Replace the intermittent movement. Set backlash as instructed above. Align the intermittent sprocket to the film trap and securely tighten the SC-1322 sprocket retaining screw.
11. Replace the intermittent flywheel. **TIME THE SHUTTER.**

ADJUSTMENTS & REPLACEMENTS (continued)

INTERMITTENT CAMSHAFT END PLAY ADJUSTMENT

NOTE: This adjustment is best performed at the factory by trained personnel.

1. Remove the large SC-0217 plug screw in the center of the intermittent cover to expose the end of the thrust bearing.
2. The bearing may be tightened or loosened by means of the screwdriver slot. It should be adjusted so that there is no perceptible end play in the camshaft, yet not tight enough to cause the camshaft to drag. Replace SC-0217 plug screw.

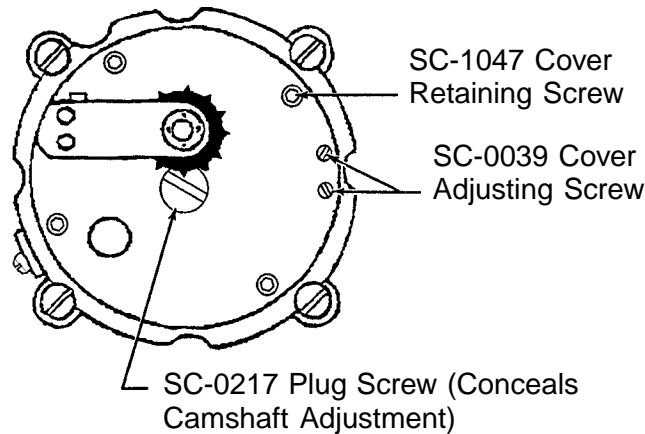

INTERMITTENT STARWHEEL AND CAMSHAFT SPACING

NOTE: This adjustment is best performed at the factory by trained personnel.

1. Dismount the intermittent sprocket shoe assembly. Slightly loosen the (4) socket head intermittent cover retaining screws (SC-1047).
2. The (2) small slot head set screws (SC-0039) at the rim of the intermittent cover in front of the intermittent shoe assembly alter the relative positions of the intermittent cover and case. This position is set at the factory, and in normal operation should *not* be readjusted.
3. The starwheel shaft mounts to the cover, and the camshaft mounts to the case. Alternately loosening and tightening the (2) SC-0039 screws shifts the position of the intermittent cover, thereby changing the spacing between the star and cam. If adjusted incorrectly, the intermittent movement may become noisy, or alternately, run too tight for normal operation. Misadjustment may contribute to premature failure of the movement.
4. **DO NOT PERFORM THIS ADJUSTMENT IF THE PROJECTOR IS UNDER WARRANTY. INTERMITTENT DAMAGE CAUSED BY FAULTY FIELD ADJUSTMENT IS NOT COVERED BY WARRANTY. Consult factory** before attempting field adjustment.

LENS TURRET AND APERTURE CHANGER (Factory Options)

ADJUSTMENT OF OPTICAL CENTERS

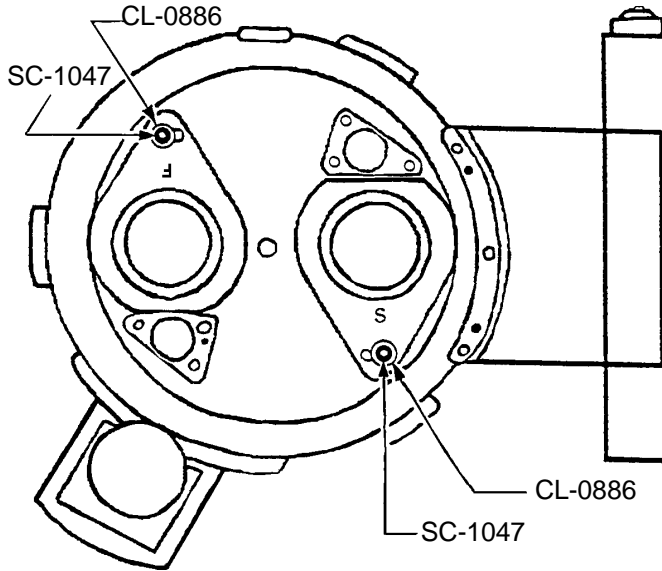

1. The RP-40 test film used for initial installation is required for this procedure. Thread a loop of this film and project it to the screen. Set the turret and aperture for 35mm SCOPE format.
 2. Loosen, but do not remove, the socket head cap screw SC-1047 located below the SCOPE lens. This screw positions the collar CL-0886.
 3. With both the SC-1047 cap screw and the CL-0886 collar loose, move the lens into position. Observe the screen, and position the lens so that the projected image of the RP-40 test film is centered on the screen. Check also the horizontal plane of the anamorphic correction.
 4. When the lens is correctly positioned, tighten the socket head cap screw SC-1047 to secure the CL-0886 collar. *Do not overtighten* the screw, as it may cause binding when focusing.
- NOTE: Flats are provided on the back of the focusing rod to allow the use of an end wrench to hold each rod for adjustment.
5. Set the turret and aperture for FLAT format, and repeat the above procedure.
 6. Before removing the RP-40 test film, set the vertical position of the projected picture. Return to SCOPE format. Loosen, but do not remove, the button head screw retaining the rotary stop bracket as it rests against the fixed rotary stop. With the bracket loose, rotate the turret to the correct height.

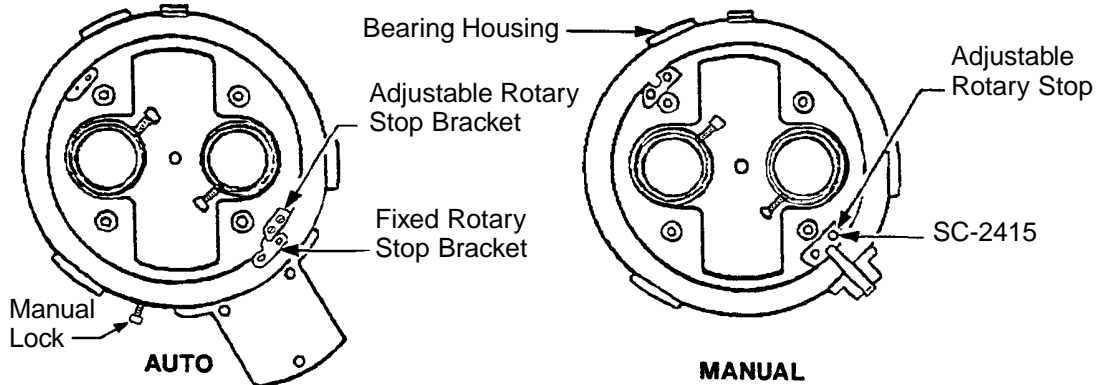

LENS TURRET ADJUSTMENTS (continued)

ADJUSTMENT OF OPTICAL CENTERS (continued)

7. When the proper height is attained, move the adjustable rotary stop up to the fixed stop, and retighten the fastening screw securely. Reset to FLAT and repeat the procedure. The Manual turret is adjusted in the same manner, but uses a different rotary stop. With either type, *set the SCOPE lens FIRST.*

TURRET BEARING ASSEMBLY ADJUSTMENT

The inner turret indexing plate, which includes the lens barrel assemblies, rotates on (3) adjustable bearing assemblies mounted to the outer ring inside housing brackets. Each bracket has (2) small set screws in the center of the housing used to adjust the clearance between the outer turret ring and the inner, indexing lens plate. If any vibration or movement exists between the outer ring and the inner plate, *it must be removed.* If any play is not removed, the inner ring will be subject to greater wear and will cause field focus problems.

1. View the front of the turret. The clearance between the outer ring and the indexing plate should appear equal around the entire circumference.
2. If end play is found between the outer ring and the lens plate at any point, begin the adjustment by either loosening or tightening the set screws in the center of the bearing housing *opposite* the greatest gap observed between the outer ring and the lens indexing plate.
3. When adjusting the set screws, tighten or loosen the screws in small increments; one-eighth of a turn or less. Generally, only a slight degree of adjustment is required, and overtightening will cause the inner plate to bind.
4. When the lens plate is visibly centered within the outer ring, index the turret between formats several times. The turret should turn freely, but with no end play.
5. Check the optical centers and picture heights of the formats and reset as required.

MOTOR & CLUTCH ASSEMBLY REMOVAL (Auto Turret)

1. Dismount the complete turret drive motor and clutch assembly from the outer turret ring by removing the (4) screws and the (2) roll pins from the BR-1306 bracket. Dismount the PE-1263 cover plate.
2. Lay the motor and clutch assembly on a flat surface with the GR-0332 gear exposed. Use a 5/64" allen wrench to loosen the set screw retaining the clutch assembly to the motor shaft.

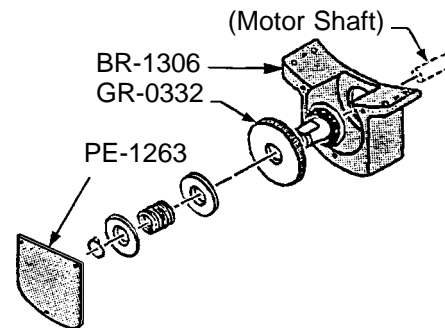

LENS TURRET ADJUSTMENTS (continued)

MOTOR & CLUTCH ASSEMBLY REMOVAL (continued)

3. Remove the clutch assembly from the motor shaft. If installing a replacement clutch, align the screw to match the hole in the shaft.
4. With the clutch assembly removed, the drive motor (MO-0134) can subsequently be dismantled by removing the (4) screws holding the motor to the BR-1306 bracket.

NOTE: In the event of a turret motor failure, remove the motor and operate the turret manually until a replacement motor is acquired. The greater weight of the anamorphic lens and adapter will hold the lenses in place, and the turret can be further secured using the MANUAL LOCK screw illustrated on page 33. Under ordinary operating conditions, leave the MANUAL LOCK screw loose. The aperture plate can be pushed in or pulled out as required; unplug if necessary. A degree of force is required to work against the aperture motor gearbox.

TURRET HINGE, TOP LOCK, & DEADSTOP

1. A slot head set screw located at the front center of the turret hinge retains a spring plunger which preloads the turret against the top lock. The screw should be set so that the spring is 50% compressed when the turret is closed and locked. Do not overtighten the screw, or the plunger will clock in place and defeat the spring action.

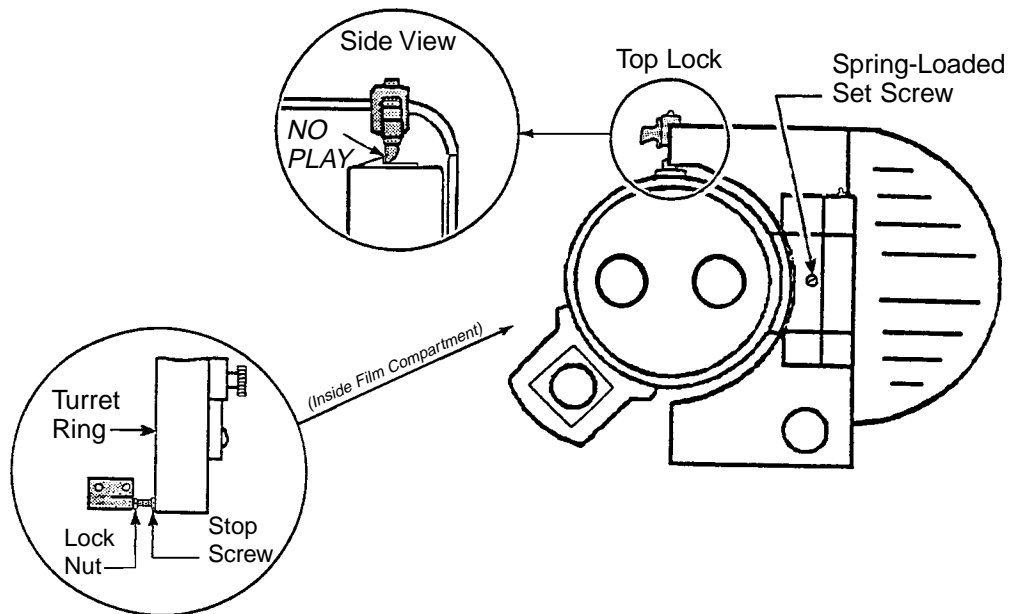

LENS TURRET ADJUSTMENTS (continued)

TURRET HINGE, TOP LOCK, & DEADSTOP (continued)

2. The top lock, mounted to the projector main frame, holds the turret closed. It is factory positioned to hold the lenses perpendicular to the optical center; *do not reposition* the top lock assembly. Raise the lever upward to release the lock and open the turret; when closing, swing the turret back until the latch on the turret ring engages firmly.
3. The turret deadstop assembly is a bracket, a stop screw, and a locknut mounted to the projector main frame inside the film compartment. The deadstop prevents overtravel and excessive wear on the hinge spring plunger. This adjustment is set at the factory and should not be disturbed unless end play or movement develops between the top lock and the latch plate on the turret ring. If such movement exists, loosen the locknut from the bracket casting and turn the hex head stop screw up to the turret until the head of the stop screw *rests* against the turret ring. At this point, tighten the locknut against the bracket casting.
4. **DO NOT ATTEMPT TO CORRECT “KEYSTONING” BY ALTERING THE SETTINGS OF THE ABOVE COMPONENTS.** The lenses *must* remain perpendicular to the optical center of the projector.

Century “JJ” Parts Catalog

Century replacement parts are available through any authorized Strong International Dealer.

Please order by *Part Number* and *Description*.

All returned goods must display a **Return Authorization** Number issued to an authorized Strong International Equipment Dealer.

STRONG INTERNATIONAL

a division of Ballantyne of Omaha, Inc,
4350 McKinley Street
Omaha, Nebraska 68112 U.S.A.
Tel 402/453-4444 • Fax 402/453-7238

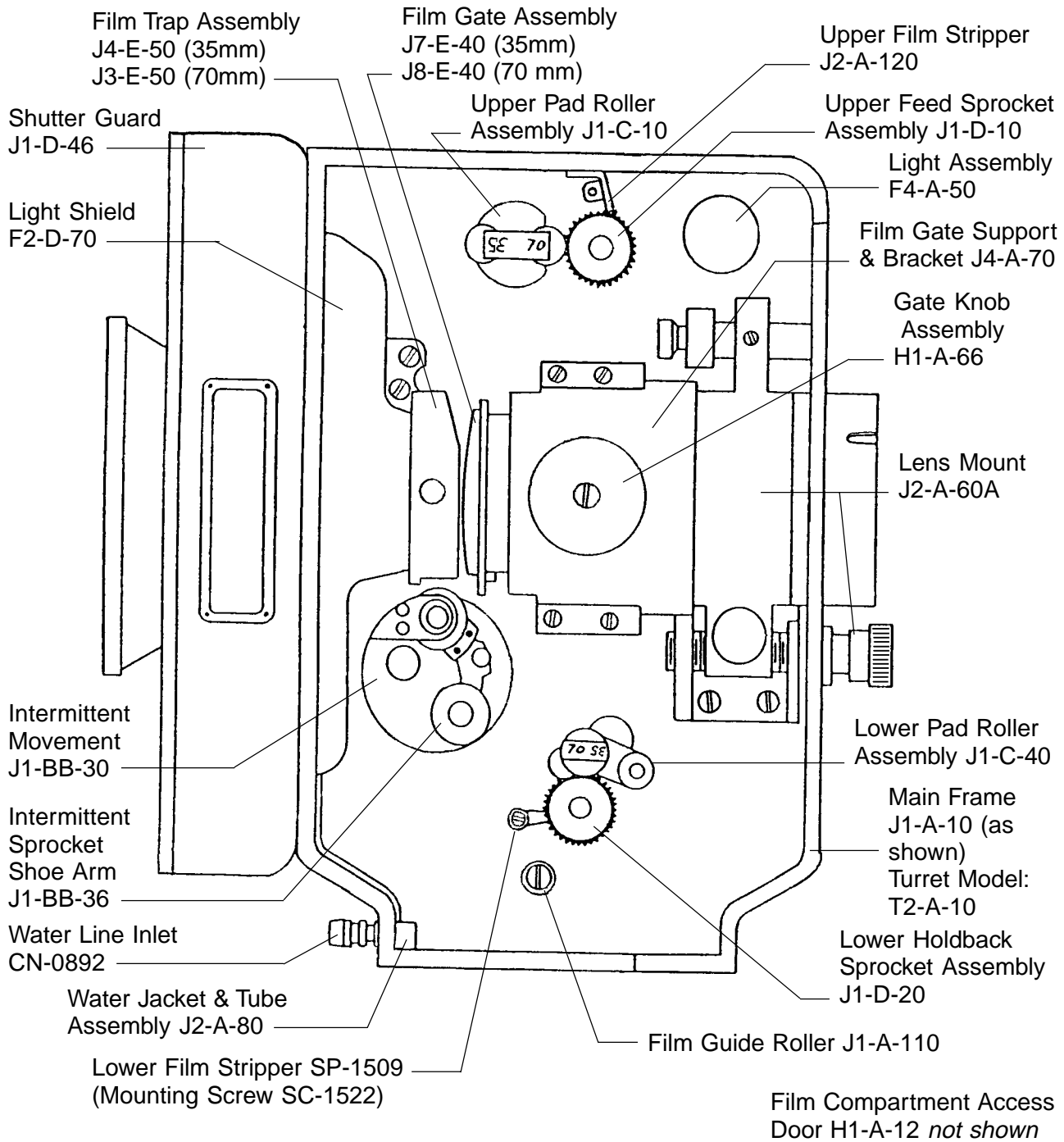

CENTURY "JJ" PROJECTOR
 Film Compartment

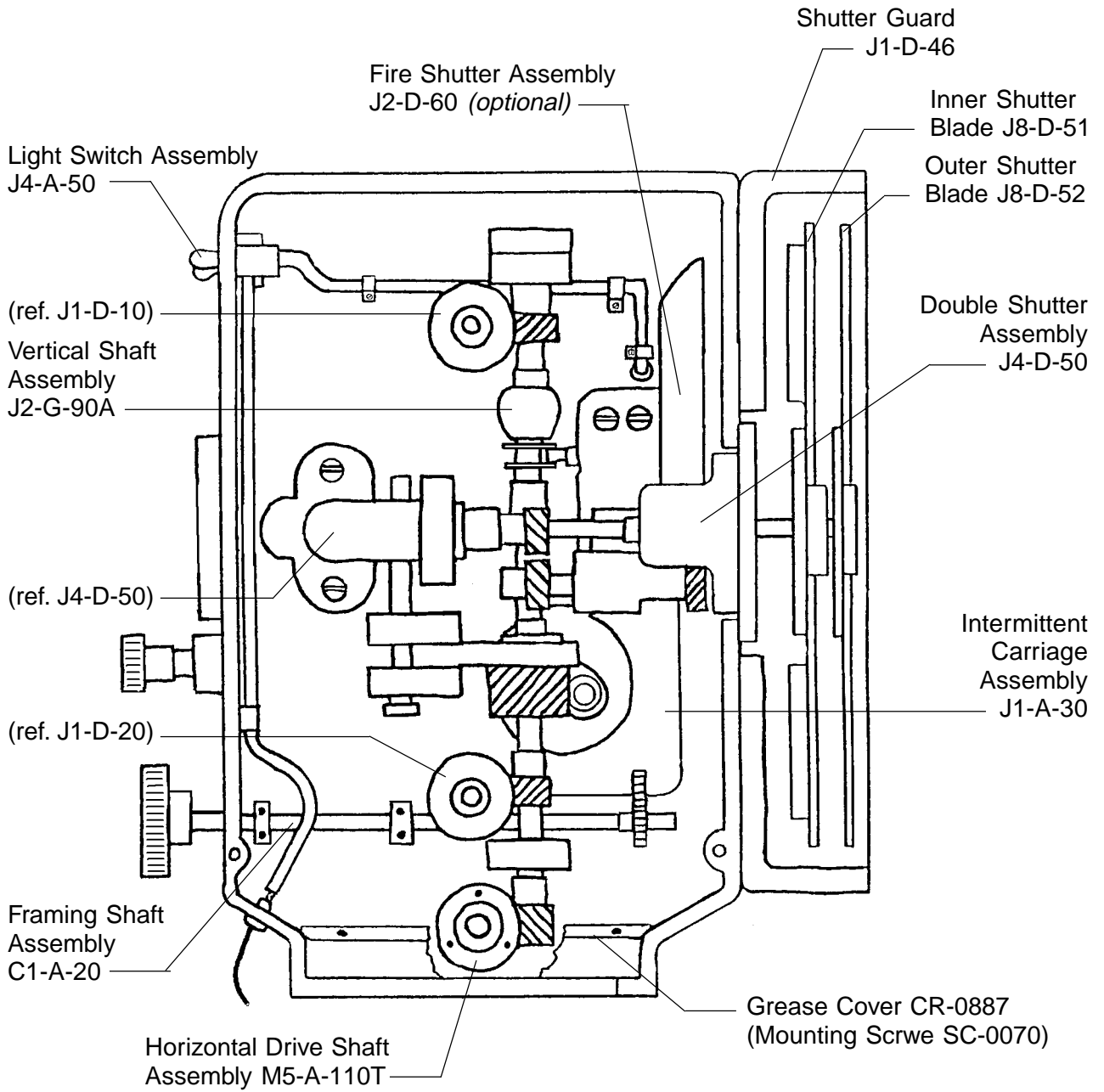

Gear Compartment Access
 Door J1-A-13 and Lower
 Cover CR-0598 *not shown*

CENTURY "JJ" PROJECTOR
 Gear Compartment

MAIN FRAME & MAJOR ASSEMBLIES

<u>Part No.</u>	<u>Description</u>
J1-A-10	Main Frame & Doors Assembly (non-Turret)
T1-A-10	Main Frame & Door (Turret Model)
J2-A-120	Upper Film Stripper Assembly
BU-00029-D	Oilite Bushing, Sprocket Shaft (4 req'd.)
BU-0747	Pad Roller Arm Retaining Bushing
CR-0598	Lower Cover, Gear Compartment
SC-0113	Fastening Screw (2 req'd.)
CR-0887	Grease Cover
SC-0070	Fastening Screw (2 req'd.)
DC-0096	Decal, Lubrication Instructions
C1-A-76	Door Catch (2 req'd.)
SC-0565	Screw (4 req'd.)
DC-0040B	Decal (UL)
FR-0082	Main Frame Casting (non-Turret, as shown)
FR-0082-T	Main Frame Casting (Turret Model)
H1-A-12	Door, Film Compartment
J1-A-13	Door, Gear Compartment
Ji-A-14	Quarter-Turn Fastener
PE-0028	Name Plate
SC-0125	Fastening Screw (2 req'd.)
PN-0021	Locating Pin (5 req'd.)
PN-0028	Locating Pin (3 req'd.)
PN-0247	Upper Carriage Stop Pin
PN-0742	Stop Pin, Pad Roller Arm
PN-1175	Lower Carriage Stop Pin
RT-0203	Main Drive Shaft Retainer (Film Side)
SC-0226	Screw, Door Fastening Link (2 req'd.)
SC-0661	Screw, Door Hinge (12 req'd.)
SC-0905	Screw, Pad Roller Arm Retaining
SC-1492	Screw, Pad Roller Arm Retaining
SC-1522	Screw, Lower Film Stripper
SD-1473	Heat Shield
SC-1145	Mounting Screw (2 req'd.)
WA-0070	Washer, Film Stripper Mounting
	NOT SHOWN
C1-T-160X	Lens Adapter
OL-0001	Century Projector Oil (1 gallon)
TU-0380	Century Gear Grease

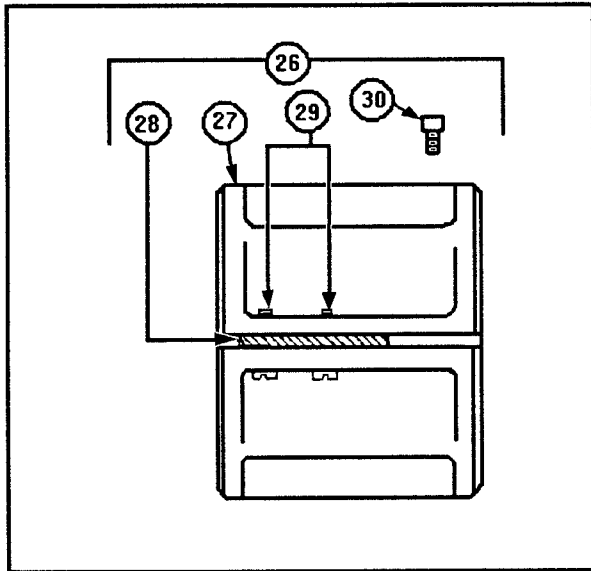
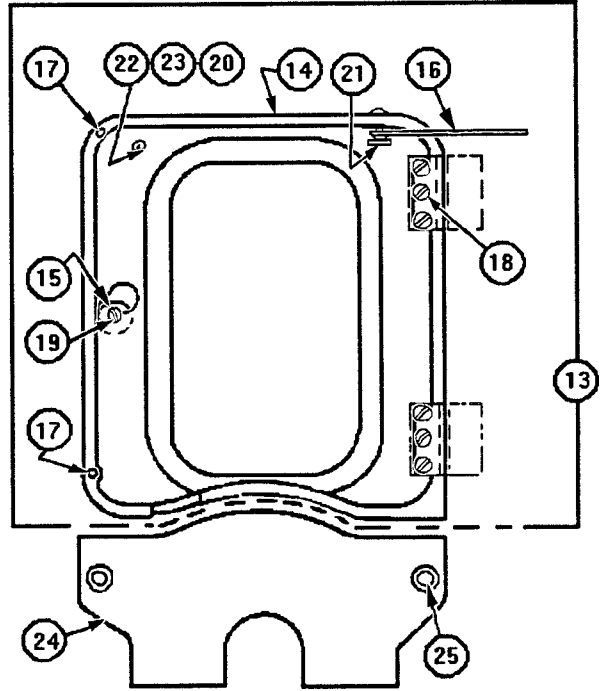
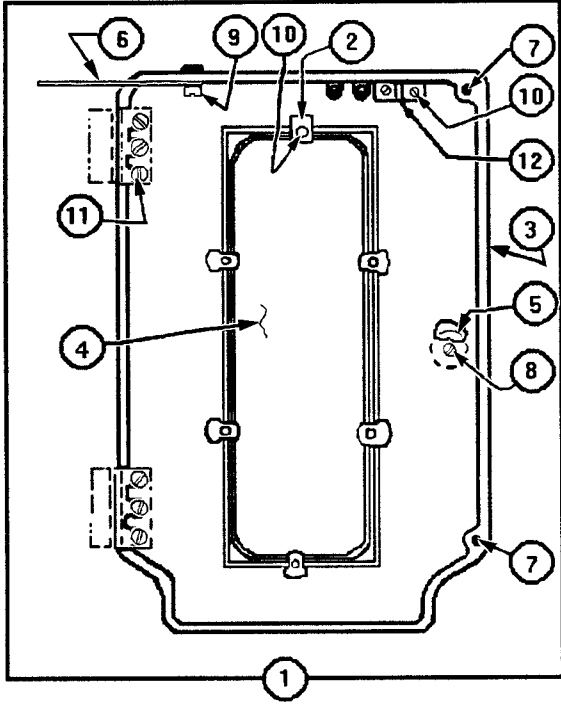

FILM COMPARTMENT DOOR ASSEMBLY (82-60052)

<u>Item</u>	<u>Part No.</u>	<u>Description</u>
1	H1-A-12	Film Compartment Door Assembly
2	CP-0020	Clamp, Door Glass (6 req'd.)
3	DO-0015	Casting, Film Compartment Door
4	GL-0015	Door Glass
5	KN-0047	Door Knob
6	LI-0007	Link, Open Limit
7	SB-0060	Door Stop, Felt (2 req'd.)
8	41-51073	Knob Mounting Screw, 8-32 x 1/2" Bind Head
9	SC-0226	Link Mounting Screw
10	SC-0123	Mounting Screw, Glass Clamp & Door Strike
11	41-51061	Hinge Mounting Screw, 8-32 x 1/4" (6 req'd.)
12	C1-A-76	Catch & Strike, Door

GEAR COMPARTMENT DOOR ASSEMBLY (82-60053)

<u>Item</u>	<u>Part No.</u>	<u>Description</u>
13	J1-A-13	Gear Compartment Door Assembly
14	DO-0072	Door Casting
15	KN-0047	Pull Knob
16	LI-0007	Door Link
17	SB-0060	Felt Bumper (2 req'd.)
18	41-51061	Hinge Screw, 8-32 x 1/4" Bind Head (6 req'd.)
19	ST-2465	Door Fastening Stud, Quarter-Turn
20	SC-0226	Link Screw
21	41-51073	Knob Screw, 8-32 x 1/2" Bind Head
22	RI-0624	Retaining Ring
23	SG-2464	Door Fastening Spring

Associated Parts

24	CR-0598	Cover, Operating Side
25	SC-0113	Cover Mounting Screw (2 req'd.)

LENS BUSHING & CLAMPING SCREW ASSEMBLY (82-60026)

<u>Item</u>	<u>Part No.</u>	<u>Description</u>
26	C1-T-160X	Lens Bushing & Clamping Screw Assembly
27	BU-0193X	Casting, Lens Bushing
28	PE-1040	Bushing Plate, Rubber
29	SC-0574	Clamping Screw (2 req'd.)
30	SC-2238X	Locating Screw

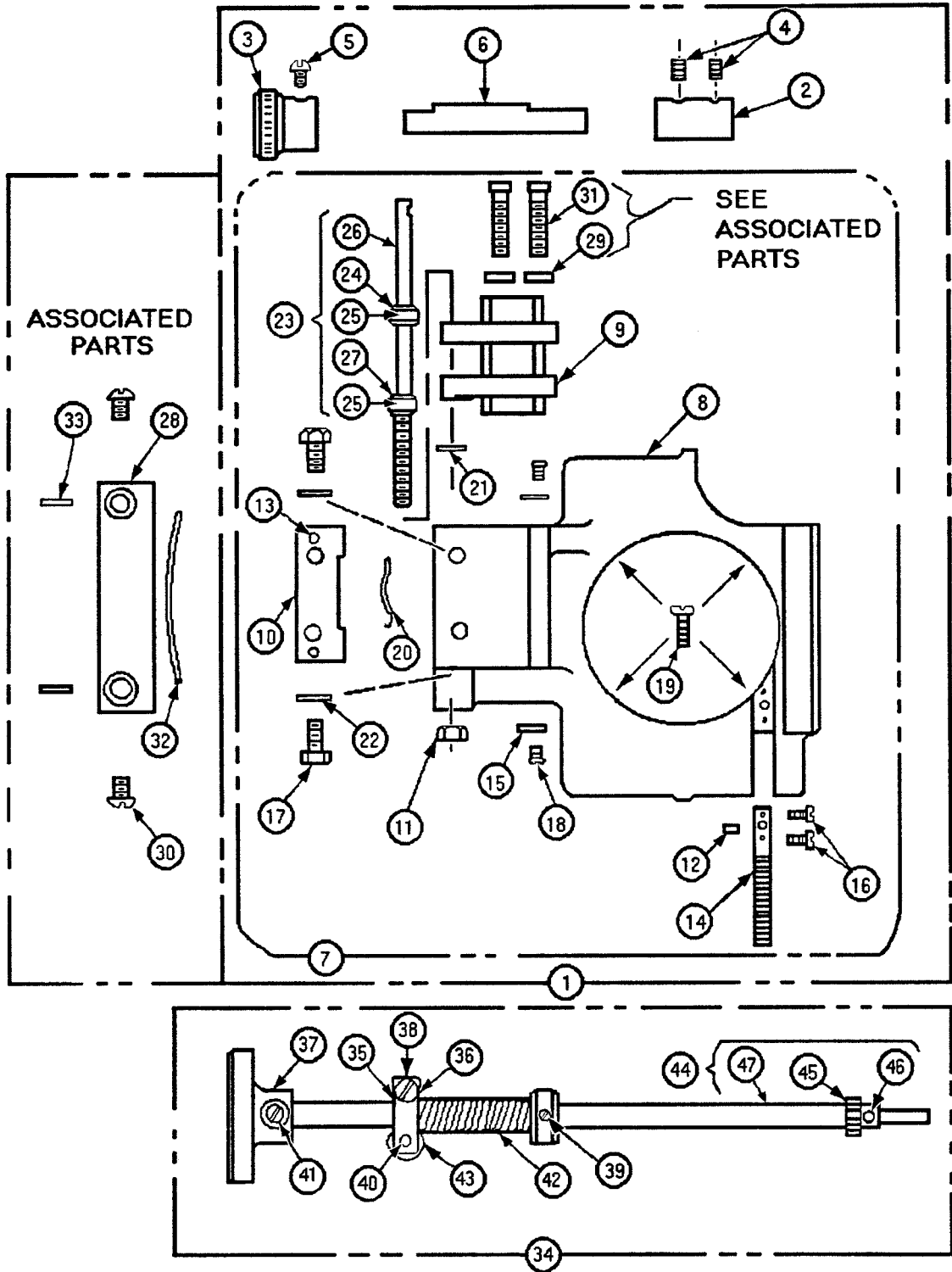

NOTE: Shutter Fine Adjustment (Items 1-6 & Item 23, with associated parts) *not* used after 1993.

INTERMITTENT CARRIAGE & SHORT SHUTTER ADJUSTMENT ASSEMBLY
(82-60104)

<u>Item</u>	<u>Part No.</u>	<u>Description</u>
1	C2-A-31	Intermittent Carriage & Shutter Adjustment Assembly
	C2-A-33	Carriage Assembly
2	CG-0014	Coupling
3	KN-0043	Knob
4	2966	Coupler Set Screw, 10-32 x 1/8"
5	00254000	Knob Screw, 8-32 x 1/4" Fillister Head
6	ST-2378	Shutter Adjusting Shaft

INTERMITTENT CARRIAGE ASSEMBLY (82-60105)

<u>Item</u>	<u>Part No.</u>	<u>Description</u>
7	C2-A-33	Intermittent Carriage Assembly
	V1-A-32	Shutter Adjustment Screw
8	CA-0004	Carriage Casting
9	BR-0012	Bracket Casting
10	GI-0006	Gib Casting
11	NU-0070	Adjustment Nut
12	PN-0022	Rack Pin
13	PN-0811	Gib Pin (2 req'd.)
14	RK-0004	Framing Rack (Order 81-98152)
15	RT-0003	Spring Retainer (2 req'd.)
16	SC-0075	Rack Screw (2 req'd.)
17	00687000	Gib Screw, 1/4-20 x 1/2" Hex Head (2 req'd.)
18	41-51028	Spring Screw, 6-32 x 1/4" Pan Head (2 req'd.)
19	SC-0106	Intermittent Retaining Screw (4 req'd.)
20	SG-0100	Spring
21	WA-0011	Washer
22	WA-0132	Lockwasher

NOTE: Shutter Fine Adjustment (Items 1-6, Item 23 & Associated Parts) discontinued in 1993.

SHUTTER ADJUSTMENT SCREW & COLLAR ASSEMBLY (82-20357)

<u>Item</u>	<u>Part No.</u>	<u>Description</u>
23	V1-A-32	Screw & Collar Assembly
24*	CL-0007	Collar
25*	PN-0103	Pin (3 req'd.)
26*	SC-0061	Screw
27*	CL-0195	Collar

* Order V1-A-32

Associated Parts

28	GI-0001	Intermittent Carriage Gib
29	SA-0752	Bracket Screw Spacer (2 req'd.)
30	SC-0071	Gib Screw (2 req'd.)
31	SC-0751	Bracket Screw (2 req'd.)
32	SG-0928	Spring
33	WA-0132	Lockwasher

FRAMING SHAFT ASSEMBLY (82-60095)

<u>Item</u>	<u>Part No.</u>	<u>Description</u>
34	C1-A-20	Framing Shaft Assembly
	C1-A-21	Shaft & Pinion Assembly
35	CL-0012	Collar
36	CP-0001	Clamp (2 req'd.)
37	KN-0044	Framing Knob
38	41-51107	Screw, 10-32 x 7/8" Fillister Head
39	SC-0074	Set Screw, 1/4-20 x 1/4"
40	SC-0132	Screw, 10-32 x 1-1/8" Fillister Head
41	41-51365	Set Screw, 10-32 x 3/8"
42	SG-0041	Spring
43	WA-0011	Washer

FRAMING SHAFT & PINION ASSEMBLY (82-20055)

<u>Item</u>	<u>Part No.</u>	<u>Description</u>
44	C1-A-21	Shaft & Pinion Assembly
45	PI-0004*	Pinion
46	PN-0029*	Pin
47	ST-0001*	Framing Shaft

* Order C1-A-21; Sold as Assembly *only*

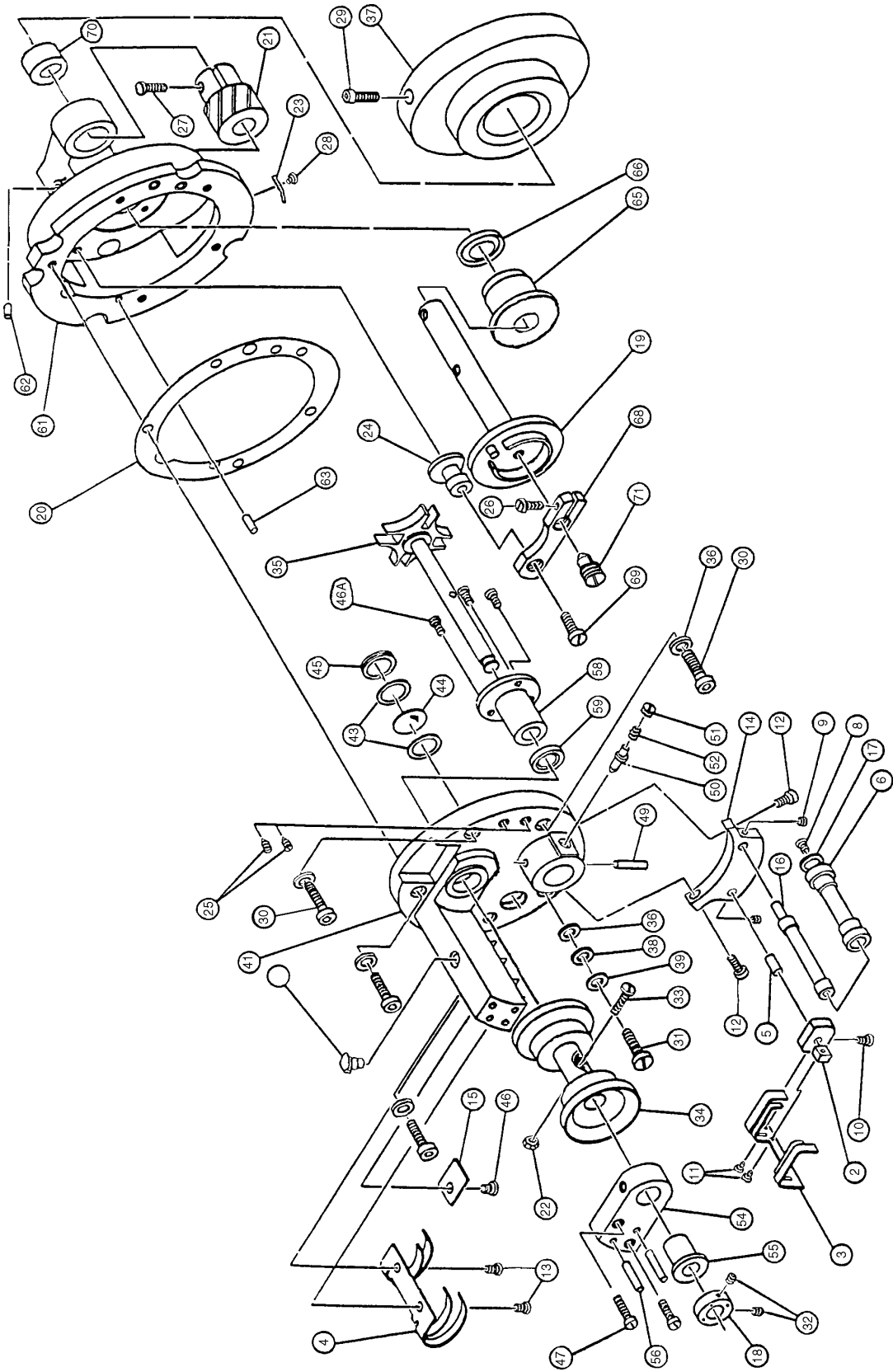

CENTURY "JJ" INTERMITTENT MOVEMENT (82-60067)

<u>Item</u>	<u>Part No.</u>	<u>Description</u>
1	J1-BB-30C	Intermittent Movement (less Item 37 Flywheel)
	J1-BB-26	Intermittent Sprocket Shoe Arm Assembly (70mm)
	F1-BB-26	Intermittent Sprocket Shoe Arm Assembly (35mm)
	J1-BB-16	Intermittent Cover Assembly
	J1-BB-17	Intermittent Case Assembly
	J1-BB-31	Cam Thrust Ball Bearing Assembly
	J1-BB-41	Intermittent Loop Stabilizer Assembly
2	BR-1251	Bracket
3	PE-1281	Lower Loop Stabilizer Plate
4	PE-1282	Upper Loop Stabilizer Plate
5	PN-1185	Pin
6	RO-0207	Loop Stabilizer Roller
7	SC-0082	Stripper Retaining Screw
8	SC-0565	Retaining Screw (3 req'd.)
9	SC-0882	Set Screw (2 req'd.)
10	SC-0893	Bracket Fastening Screw
11	SC-1187	Lower Plate Fastening Screw (3 req'd.)
12	SC-1190	Bracket Fastening Screw (4 req'd.)
13	SC-0094	Screw (2 req'd.)
14	SO-2340	Support
15	SP-1326	Film Stripper
16	SU-1475	Lower Loop Roller Stud
17	WA-0109	Roller Fastening Washer
18	CL-0624	Starwheel Shaft Thrust Collar
19	CM-0528*	Camshaft
20	GA-0339	Intermittent Cover Gasket
21	GR-0007	Intermittent Driven Gear
22	NU-0081	Sprocket Fastening Nut
23	PE-0038	Stop Plate
24	SA-1479	Thrust Bracket Spacer
25	SC-0039	Cover Adjusting Screw (2 req'd.)
26	SC-0069	Thrust Bracket Screw
27	SC-0081	Gear Fastening Screw
28	SC-0134	Stop Plate Retaining Screw
29	SC-0915	Flywheel Fastening Screw
30	SC-1047	Intermittent Cover Fastening Screw (4 req'd.)

* It is recommended to replace Starwheel & Camshaft as matched pairs

INTERMITTENT MOVEMENT ASSEMBLY (continued)

<u>Item</u>	<u>Part No.</u>	<u>Description</u>
31	SC-1010	Oil Drain Screw
32	SC-1235	Set Screw, Thrust Collar
33	SC-1322	Sprocket Fastening Screw
34	SK-1480	Intermittent Sprocket, 35/70
35	SX-1476*	Starwheel Shaft
36	WA-0065	Washer, Cover Fastening Screw (2 req'd.)
37	WH-0199	Flywheel
38	WA-0012	Drain Screw Washer, Copper
39	WA-0126	Drain Screw Washer, Fibre
40	J1-BB-16	Intermittent Cover Assembly
	J1-BB-40	Starwheel Shaft Bushing & Ring Assembly
	H1-BB-34	Starwheel Bearing Bracket Assembly
41	CR-0608	Intermittent Cover Casting
42	CU-0658	Oil Fill Cup
43	GA-0020	Sight Glass Gasket
44	GG-0019	Sight Glass Window
45	NU-0010	Nut
46	SC-0082	Stripper Fastening Screw (2 req'd.)
47	SC-1190	Bracket Mounting Screw (2 req'd.)
48	SP-1326	Film Stripper
49	PN-0634	Locating Pin
50	PU-0619	Plunger
51	SC-1211	Spring Retaining Screw
52	SG-1210	Compression Spring
53	H1-BB-34	Starwheel Bearing Bracket Assembly
54	BR-0644	Outboard Bearing Bracket
55	BU-0646-N	Bushing
56	PN-0665	Locating Pin (2 req'd.)
57	J1-BB-40	Starwheel Bushing & Ring Seal Assembly
58	BU-1274	Inner Starwheel Bushing
59	RI-0576	Seal Ring
60	J1-BB-17	Intermittent Case Assembly
61	CS-0609	Case Casting
62	PG-0159	Oil Hole Plug, Felt
63	PN-0032	Adjusting Arm Pin

* It is recommended to replace Starwheel & Camshaft as matched pairs.

INTERMITTENT MOVEMENT ASSEMBLY (continued)

<u>Item</u>	<u>Part No.</u>	<u>Description</u>
64	H1-BB-36	Inner Cam Bushing & Seal Assembly
65	BU-1257	Inner Camshaft Bushing
66	RI-0609	Seal Ring
67	H1-BB-31	Cam Thrust Bearing & Bracket Assembly
	C1-BB-11	Thrust Bearing Assembly
68	BR-0643	Camshaft Thrust Bracket
69	SC-0085	Screw
70	BU-0040-N	Outer Cam Bushing
71	C1-BB-11	Thrust Bearing

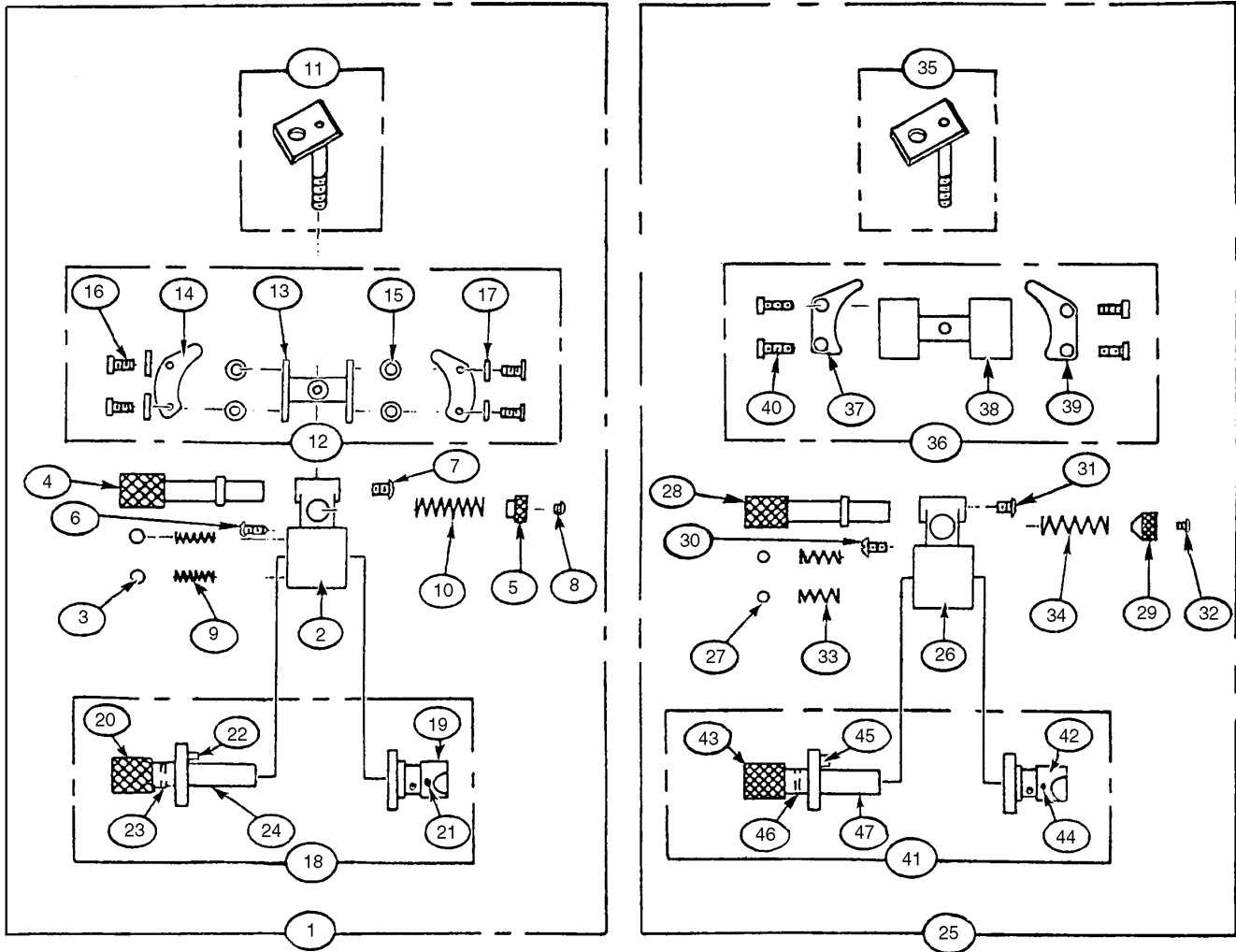

INTERMITTENT SPROCKET SHOE PAD & ARM ASSEMBLIES

<u>Item</u>	<u>Part No.</u>	<u>Description</u>
1	F1-BB-26	Intermittent Sprocket Shoe Pad & Arm Assembly, 35mm
2	AR-0092	Arm Casting
3	BL-0018	Steel Ball (2 req'd.)
4	KN-0030	Knob, Operating Lever
5	NU-0046	Spring Tensioning Nut
6	SC-0082	Stud Plate Fastening Screw
7	SC-0127	Mounting Screw, Operating Lever
8	SC-0708	Stop Screw
9	SG-0021	Compression Spring, Arm Detent (2 req'd.)
10	SG-1464	Compression Spring, Shoe Tension
11	C1-BB-27	Spring Plate & Stud Assembly

INTERMITTENT SPROCKET SHOE PAD & ARM ASSEMBLIES (continued)

<u>Item</u>	<u>Part No.</u>	<u>Description</u>
12	F1-BB-28	Intermittent Sprocket Shoe & Pad Assembly
13	PA-0194	Inner Pad, 35mm
14	PA-0195	Outer Pad, 35mm (2 req'd.)
15	SA-0033	Spacer (4 req'd.)
16	SC-0877	Screw (4 req'd.)
17	WA-0151	Lockwasher (4 req'd.)
18	F1-BB-29	Intermittent Pad Stud & Bushing Assembly
19	BU-0027	Thrust Bushing
20	KN-0024	Knurled Knob
21	PN-0025	Taper Pin
22	PN-0036	Stop Pin
23	PN-0068	Locking Pin
24	SU-0004	Roller Stud
25	J1-BB-26	Intermittent Sprocket Shoe Pad & Arm Assembly, 70mm
26	AR-0092	Arm Casting
27	BL-0018	Steel Ball
28	KN-0030	Knob, Operating Lever (2 req'd.)
29	NU-0046	Spring Tensioning Nut
30	SC-0082	Stud Plate Fastening Screw
31	SC-0127	Mounting Screw, Operating Lever
32	SC-0708	Stop Screw
33	SG-0021	Compression Spring, Arm Detent (2 req'd.)
34	SG-1464	Compression Spring, Shoe Tension
35	C1-BB-27	Spring Plate & Stud Assembly
36	J2-BB-28	Intermittent Sprocket Shoe & Pad Assembly
37	PA-0890	Outer Pad, 70mm (Outboard)
38	PA-0891	Inner Pad, 70mm
39	PA-0892	Outer Pad, 70mm (Inboard)
40	SC-1851	Screw (4 req'd.)
41	F1-BB-29	Intermittent Pad Stud & Bushing Assembly
42	BU-0027	Thrust Bushing
43	KN-0024	Knurled Knob
44	PN-0025	Taper Pin
45	PN-0036	Stop Pin
46	PN-0068	Locking Pin
47	SU-0004	Roller Stud

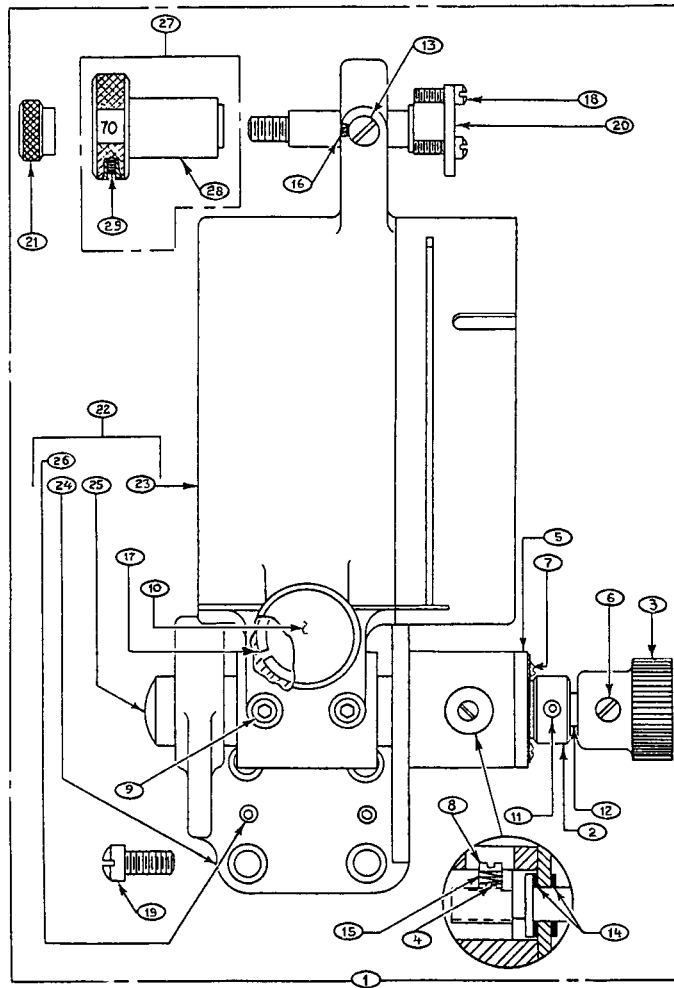

LENS BARREL ASSEMBLY (82-60232)

<u>Item</u>	<u>Part No.</u>	<u>Description</u>
1	J2-A-60A	Lens Barrel Assembly
2	CL-0554	Collar, Focusing Screw
3	KN-0045	Focusing Knob
4	PG-0301	Screw Plug
5	SA-1226	Focus Screw Spacer
6	SC-0072	Knob Fastening Screw
7	SC-0105	Spacer Fastening Screw (3 req'd.)
8	SC-0678	Plug Spring Retaining Screw
9	SC-0905	Rod Fastening Screw
10	SC-1229	Lens Clamp Screw
11	SC-1231	Eccentric Adjusting Screw (2 req'd.)

LENS BARREL ASSEMBLY (continued)

<u>Item</u>	<u>Part No.</u>	<u>Description</u>
12	SC-0579	Eccentric Lock Screw (2 req'd.)
13	SC-1236	Retaining Screw
14	SC-1362	Focusing Screw
15	SG-0999	Spring
16	WA-0163	Thrust Washer (2 req'd.)
17	WA-0203	Split Washer
18	SC-0088	Fastening Screw
19	SC-0137	Support Casting Fastening Screw (4 req'd.)
20	SU-1392	Eccentric Bushing Stud
21	NU-0079	Lock Nut
22	H1-A-58	Lens Mount Bracket & Focus Rod Assembly
23	BR-0601	Lens Mount Casting
24	BR-1304	Support Bracket Casting
25	RD-0150	Focus Rod
26	SC-0981	Adjusting Screw (2 req'd.)
27	J1-A-61	Lens Mount Eccentric Bushing Assembly
28	BU-0716	Eccentric Bushing
29	SC-2438	Bushing Screw

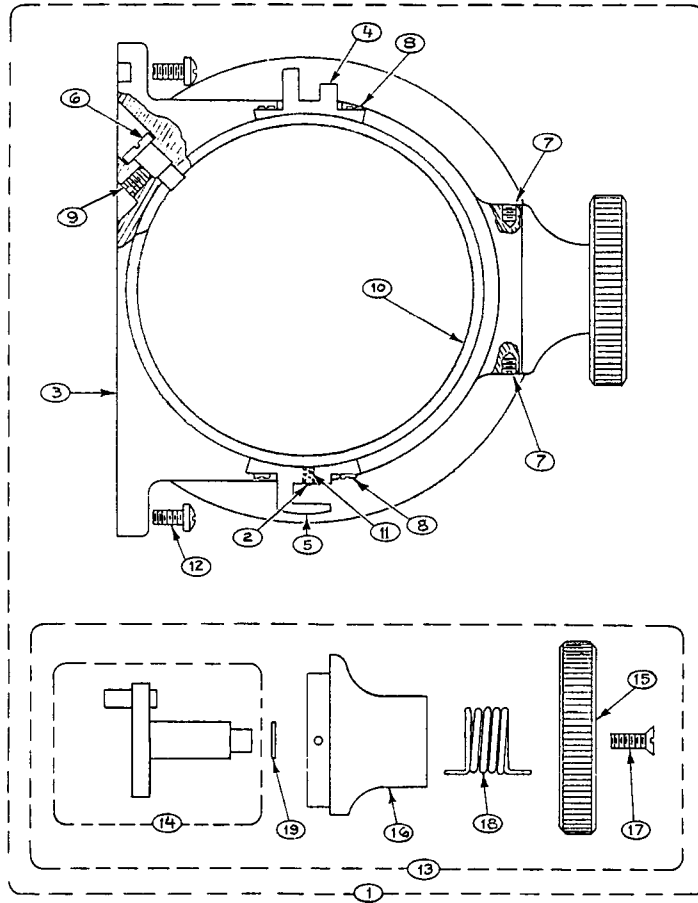

FILM GATE TUBE & BRACKET ASSEMBLY

<u>Item</u>	<u>Part No.</u>	<u>Description</u>	<u>Item</u>	<u>Part No.</u>	<u>Description</u>
1	J4-A-70	Film Gate Support Tube & Bracket Assembly	11	SG-1213	Retaining Spring
2	BL-0596	Retaining Ball	12	SC-0137	Screw (4 req'd.)
3	BR-0928	Support Bracket Casting	13	H1-A-66	Gate Lock Knob & Shaft Assembly
4	BR-0930	Upper Support Bracket	14	C1-A-67	Shaft & Pin Assembly
5	BR-0931	Lower Support Bracket	15	KN-0027	Gate Opening Knob
6	EC-0001	Gate Alignment Eccentric	16	LO-0045	Gate Lock
7	SC-0131	Screw (2 req'd.)	17	SC-0099	Fastening Screw
8	SC-1212	Screw (4 req'd.)	18	SG-0014	Torsion Spring
9	SC-1355	Eccentric Lock Screw	19	WA-0135	Washer
10	TU-0175	Gate Support Tube			

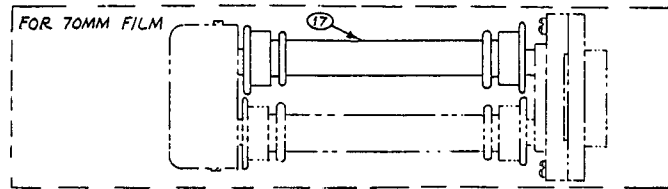
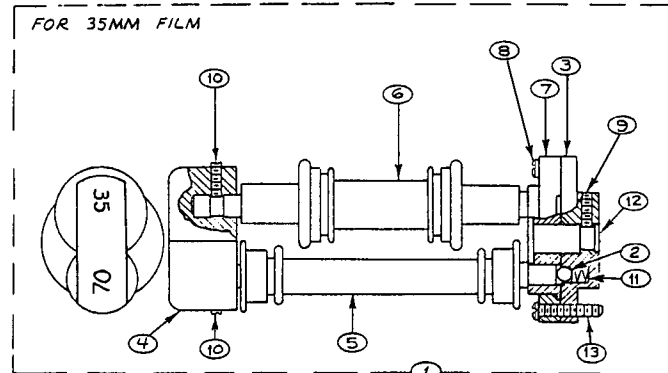
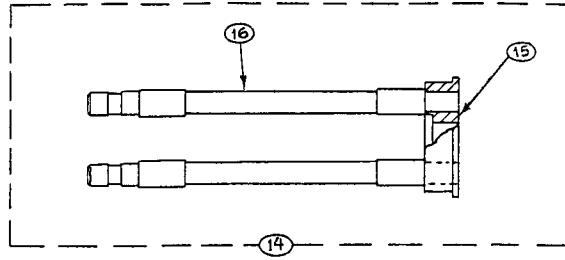

UPPER PAD ROLLER ASSEMBLY

<u>Item</u>	<u>Part No.</u>	<u>Description</u>	<u>Item</u>	<u>Part No.</u>	<u>Description</u>
1	J1-C-10	Pad Roller Arm Assembly	10	SC-0873	Set Screw (2 req'd.)
2	BL-0018	Steel Ball	11	SG-1230	Spring (2 req'd.)
3	BU-0714	Bushing	12	SU-1490	Stud
4	KN-0058	Knob	13	SC-1492	Screw (3 req'd.)
5	RO-0209-D	Roller, 70mm	14	J1-C-11	Stud & Retaining Plate
6	RO-0210	Roller, 35mm	15	PE-0722	Retaining Plate
7	RT-0211	Retainer	16	SU-1491	Stud
8	SC-0088	Retaining Screw	17	RO-0209	Roller, 70mm
9	SC-0873	Set Screw (2 req'd.)			

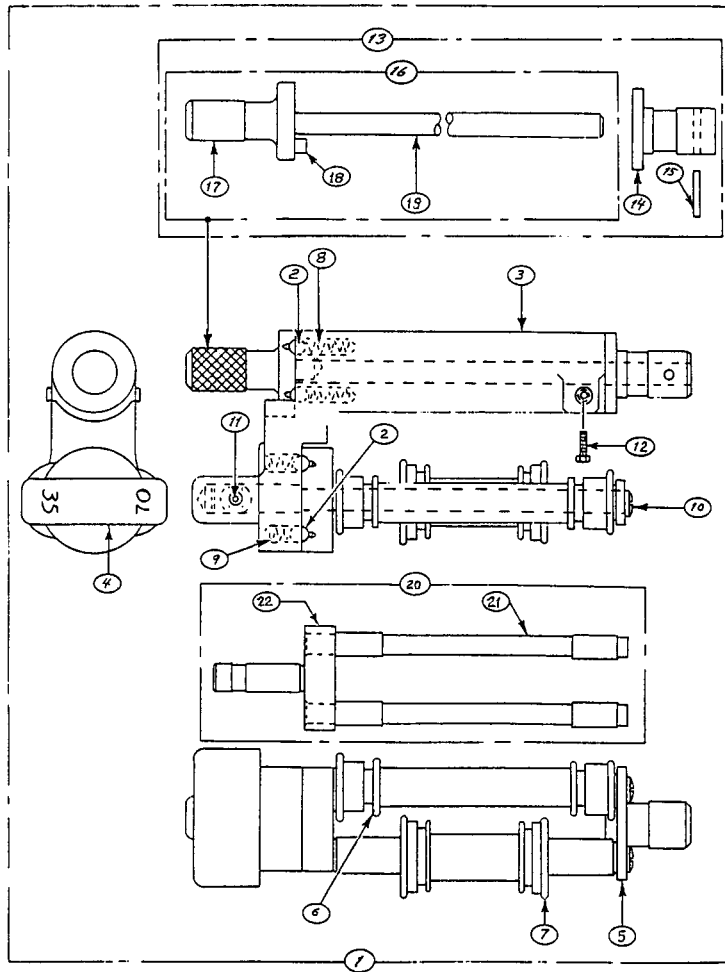

LOWER PAD ROLLER ASSEMBLY

<u>Item</u>	<u>Part No.</u>	<u>Description</u>	<u>Item</u>	<u>Part No.</u>	<u>Description</u>
1	J1-C-40	Pad Roller Assembly	13	J1-C-41	Stud, Knob, & Bushing Assembly
2	BL-0018	Steel Ball (4 req'd.)	14	BU-0027	Bushing
3	AR-0118	Arm	15	PN-0025	Pin
4	KN-0077	Knob	16	J1-C-42	Stud & Knob Assembly
5	PE-0747	Spacer Plate	17	KN-0024	Knob
6	RO-0209-D	Roller, 70mm	18	PN-0036	Stop Pin
7	RO-0210	Roller, 35mm	19	SU-1493	Stud
8	SG-0021	Spring, Long (2 req'd.)	20	J1-C-43	Roller Stud Assembly
9	SG-1230	Spring, Short (2 req'd.)	21	SU-1498	Roller Stud
10	SC-0112	Screw (2 req'd.)	22	SU-1496	Retaining Stud
11	SC-0873	Screw (2 req'd.)			
12	SC-2287	Stop Screw			

SPROCKET SHAFT & ROLLER ASSEMBLIES

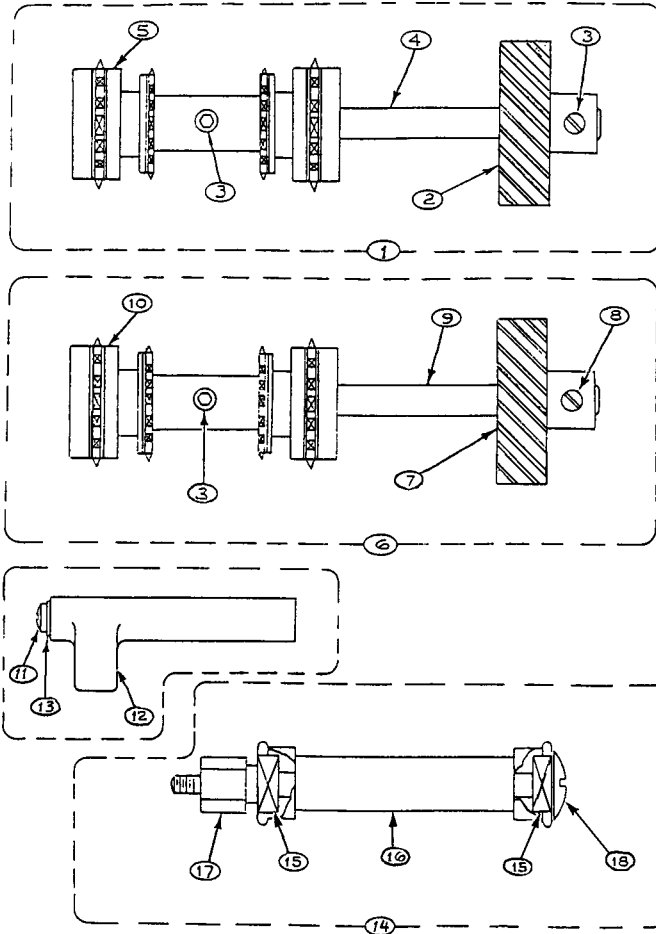

Item	Part No.	Description
1	J1-D-10	Upper Sprocket Assembly
2	GR-0010	Driven Gear
3	SC-1190	Fastening Screw (2 req'd.)
4	ST-1481	Sprocket Shaft
5	SK-1482	Feed Sprocket
6	J1-D-20	Lower Sprocket Assembly
7	GR-0010	Driven Gear
8	SC-1190	Fastening Screw (2 req'd.)
9	ST-1481	Sprocket Shaft
10	SK-1483	Holdback Sprocket
11	SC-1522	Retaining Screw
12	SP-1509	Lower Film Stripper
13	WA-0070	Washer
14	J1-A-110	Guide Roller Assembly
15	BG-1260A	Ball Bearing (2 req'd.)
16	RO-0204	Guide Roller
17	SU-1478	Roller Stud
18	SC-1233	Retaining Screw

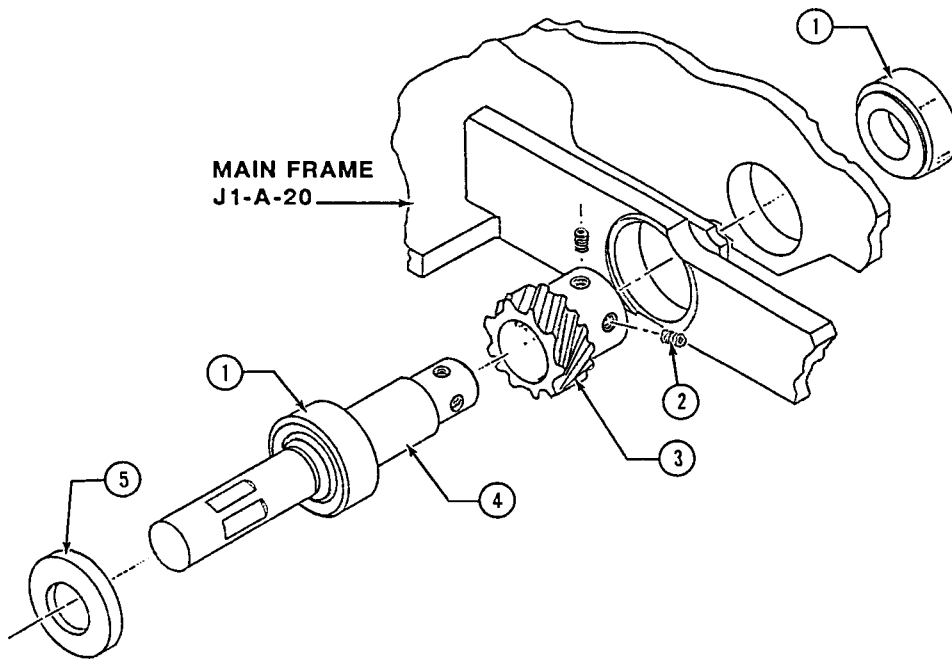

**HORIZONTAL SHAFT
M2-G-111T**

<u>Item</u>	<u>Part No.</u>	<u>Description</u>
1	BG-0006A	Ball Bearing
2	41-51184	Set Screw (2 req'd.)
3	GR-0328	Drive Gear
4	ST-2154	Drive Shaft
5	RI-0617	Oil Seal Ring

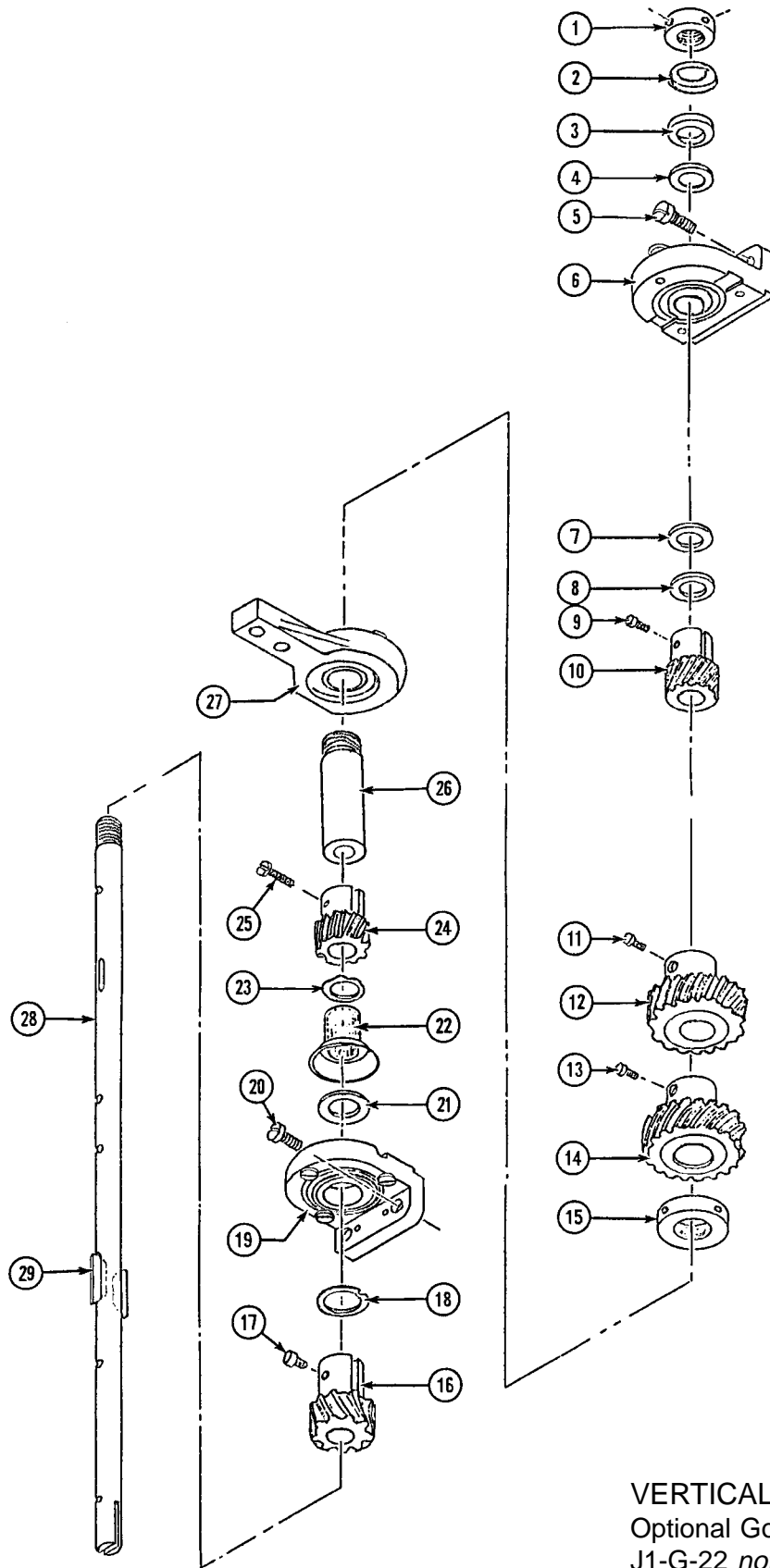

VERTICAL SHAFT ASSEMBLY
 Optional Governor Weight Assembly
 J1-G-22 *not shown*

VERTICAL SHAFT (J3-G-100B)

<u>Item</u>	<u>Part No.</u>	<u>Description</u>
1	F2-G-44	Upper Thrust Collar Assembly
2	RT-0061	Thrust Washer Retainer
3	WA-0130	Thrust Washer
4	WA-0131	Spring Washer
5	SC-1445	Screw, 1/4-20 x 5/8"
6	C1-G-32	Bearing & Bracket Assembly, Upper
-	BG-0009	Ball Bearing
-	BR-0020	Bracket, Cast
7	WA-0010	Washer 0442" I.D. x .01718" O.D.
8	WA-0003	Washer, .3906" I.D. x .750" O.D.
9	SC-0081	Gear Retaining Screw
10	GR-0005	Sprocket Shaft Drive Gear
11	SC-0915	Gear Retaining Screw
12	GR-0207	Shutter Shaft Drive Gear
13	SC-0915	Gear Retaining Screw
14	GR-0207	Shutter Shaft Drive Gear
15	NU-0001	Bearing Support Nut*
16	GR-0004	Vertical Shaft Driven Gear
17	SC-0668	Gear Retaining Screw
18	WA-0014	Spring Washer
19	V1-G-31	Bearing & Bracket Assembly, Lower
-	BG-0004	Ball Bearing
-	BR-0247	Bracket, Cast
20	SC-0143	Bracket Mounting Screw
21	WA-0003	Washer, .3906" I.D. x .750" O.D.
22	CL-0028	Bearing Collar
23	WA-0014	Spring Washer
24	GR-0005	Sprocket Shaft Drive Gear
25	SC-0081	Gear Retaining Screw
26	82-20238	Bearing Support
27	J2-G-95	Bearing Bracket Asssembly
-	BG-0006A	Ball Bearing
-	BR-0003	Bracket, Cast
28	ST-1796	Vertical Shaft
29	KY-0053-J	Woodruff Key (2 req'd.)

* included with J2-G-95 Assembly (Item 27)

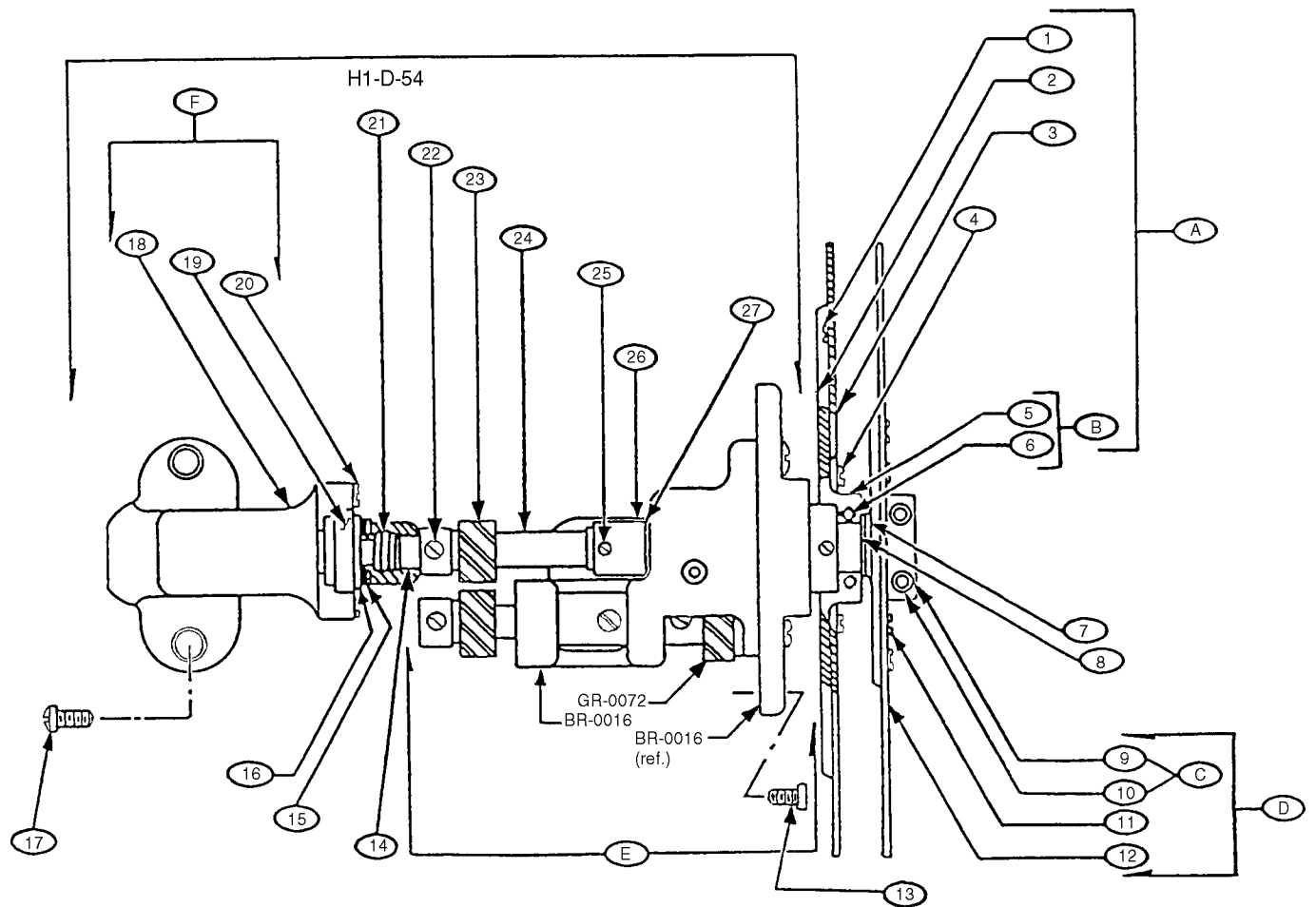

DOUBLE SHUTTER ASSEMBLY
J4-D-50C

Item	Part No.	Description
A	J8-D-51	Inner Shutter Blade & Hub Assembly
B	C2-D-56	Shutter Hub, Inner
C	C2-D-49	Shutter Hub, Outer
D	J8-D-52	Outer Shutter Blade & Hub Assembly
E	C2-D-55A	Intermediate Bracket, Gear & Bearing Assembly
F	C2-D-42	Front Support & Bearing Assembly
-	H1-D-54	Shaft, Bracket & Bearing Assembly, Double Shutter
1	SC-0094	Shutter Air Vane Mounting Screw
2	BD-0026	Air Vane (2 req'd.)
3	BD-1065	Inner Shutter Blade, 90°
4	SC-0128	Shutter Blade Mounting Screw
5	HB-0045	Shutter Hub Casting, Inner

DOUBLE SHUTTER ASSEMBLY

Parts List, continued

<u>Item</u>	<u>Part No.</u>	<u>Description</u>
6	SC-0574	Hub Clamping Screw
7	SG-0016	Spring Washer
8	SA-2044	Spacer
9	HB-0044	Shutter Hub Casting, Outer
10	SC-0574	Hub Clamping Screw
11	SC-0128	Shutter Blade Mounting Screw
12	BD-1064	Outer Shutter Blade, 90°
13	SC-1116	Bracket Mounting Screw
-	BR-0015	Bearing Bracket, Cast
14	RT-0062	Shutter Shaft Retainer
15	WA-0130	Thrust Washer, Neoprene
16	WA-0131	Thrust Washer, Steel
17	SC-0137	Bracket Mounting Screw
18	BR-0186	Bearing Bracket, Cast
19	BG-0009	Ball Bearing
20	SC-0127	Bearing Retaining Screw
21	SG-0068	Compression Spring
22	SC-0081	Gear Retaining Screw
23	GR-0007	Shutter Driven Gear (2 req'd.)
24	ST-1397	Shutter Shaft, Direct
-	ST-0765	Shutter Shaft, Intermediate (below ST-1397)
-	BG-0010	Ball Bearing for ST-0765 (2 req'd.)
-	GR-0072	Driven Gear for ST-0765
25	SC-0023	Collar Retaining Screw
26	CL-0128	Thrust Collar
27	WA-0130	Thrust Washer, Neoprene
-	WA-0131	Thrust Washer, Steel
	BR-0016	Intermediate Shutter Shaft Bracket Casting
	SC-0137	Fastening Screw BR-0015 to BR-0016
	BG-0009	Ball Bearing, Shutter Shaft (inside BR-0016)
	GR-0013	Drive Gear, Intermediate Shutter Shaft (inside BR-0016)

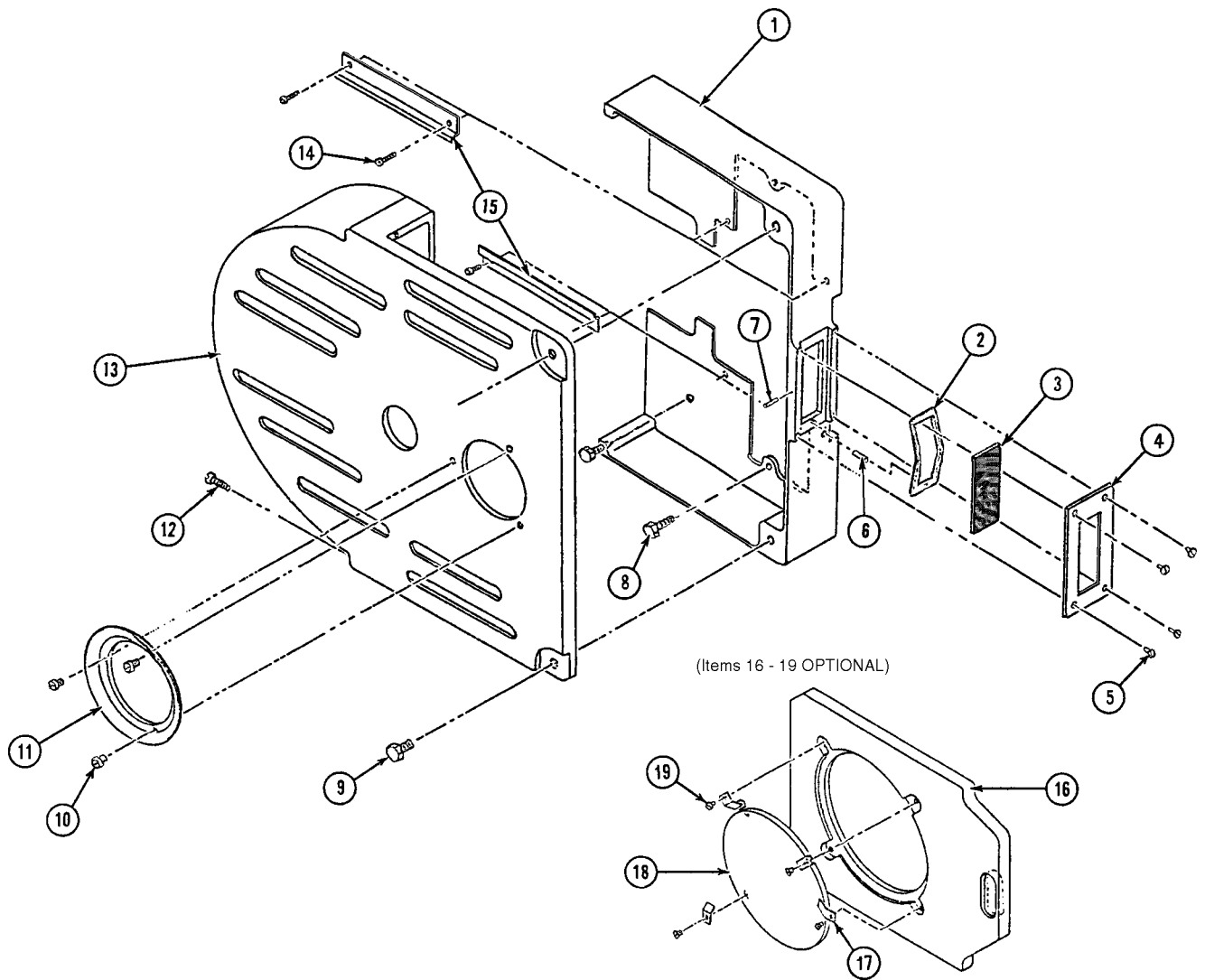

SHUTTER GUARD ASSEMBLY

J1-D-46 (Items 1 - 15)

Item	Part No.	Description	Item	Part No.	Description
1	GD-0278	Shutter Guard Casting, Fixed	12	SC-0679	Screw, 10-32 x 1-1/4"
2	SG-0044	Leaf Spring, Sight Glass	13	GD-0185	Shutter Guard Casting, Removable
3	GL-0018	Sight Glass, Tinted	14	SC-0094	Mounting Screw
4	HO-0005	Sight Glass Holder	15	SG-1995	Retaining Spring
5	SC-0092	Screw, 2-56 x 1/4"	-	J3-A-90	Heat Filter Assembly
6	PN-0647	Pin	16	HO-0113	Filter Holder
7	PN-0280	Pin, Shutter Time Indicator	17	CP-0734	Clamp (4 req'd.)
8	SC-1109	Mounting Screw, 1/4-20	18	FI-0135	Filter, Quartz
9	SC-0078	Mounting Screw, 1/4-20	19	SC-1016	Clamp Mounting Screw
10	SC-1265	Screw, 8-32 x 3/8"			
11	HD-0078	Light Shield Hood			

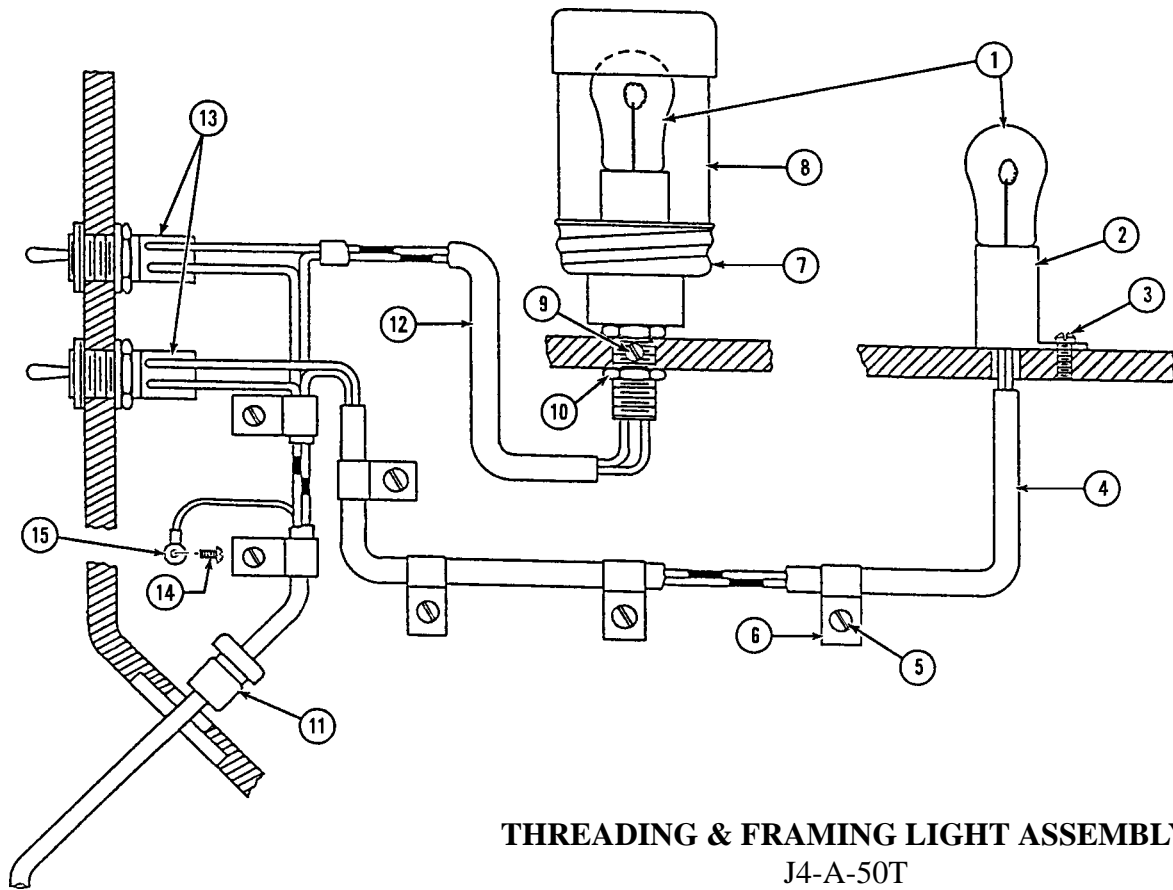

THREADING & FRAMING LIGHT ASSEMBLY
J4-A-50T

WIRING DIAGRAM

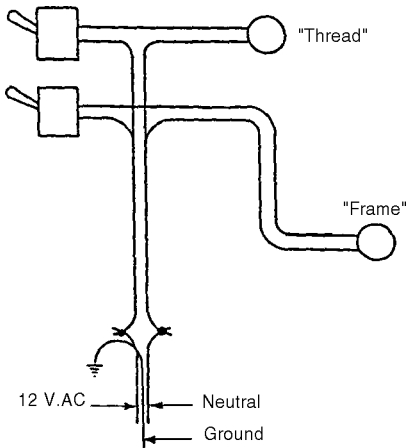

Item	Part No.	Description
1	LP-0122	Bulb, 12 V.AC, 6 Watt
2	SF-1097	Socket
3	SC-0112	Mounting Screw
4	TU-0134	Insulating Tube
5	41-51032	Screw, 6-32 x 1/4"
6	CP-0883	Cable Clamp
7	C3-A-55	Threading Light Socket Assembly
8	C3-A-53	Shield Assembly
-	SD-0997	Shield Cap
-	SD-2113	Shield Tube, Glass
9	SC-0172	Socket Locating Screw
10	NU-0006	Socket Nut
11	CP-0890	Strain Relief Cable Clamp
-	CD-0889A	Framing Lamp Cord
12	TU-0135	Insulation Tube
13	SW-0064	Toggle Switch
14	SC-2096	Ground Screw
15	LU-0117	Ground Lug

FILM GATES

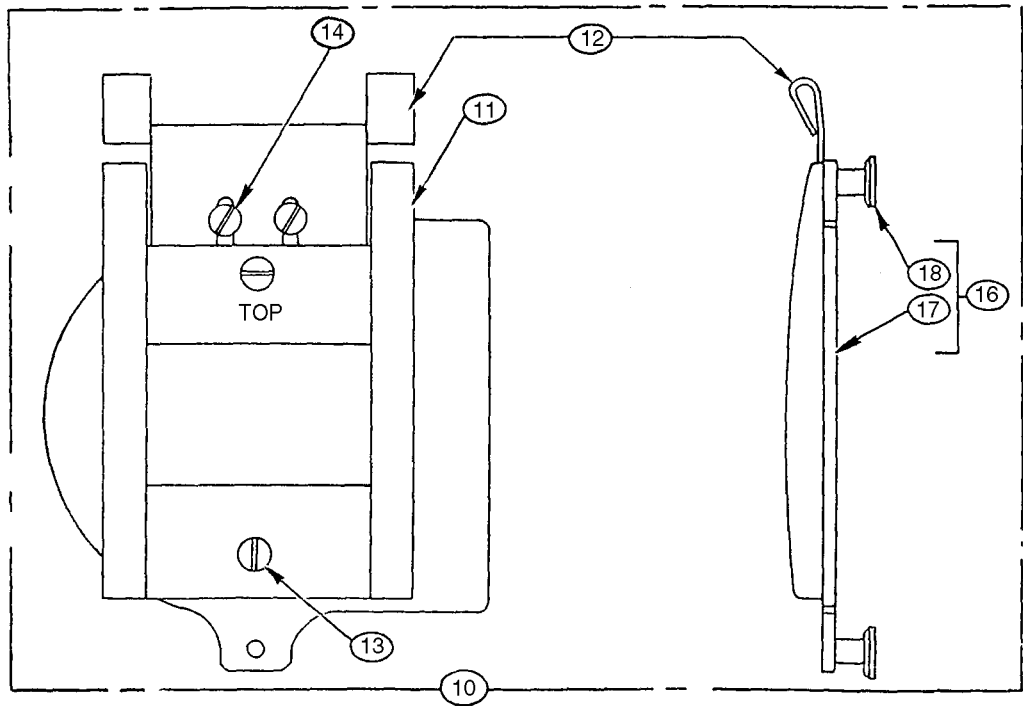
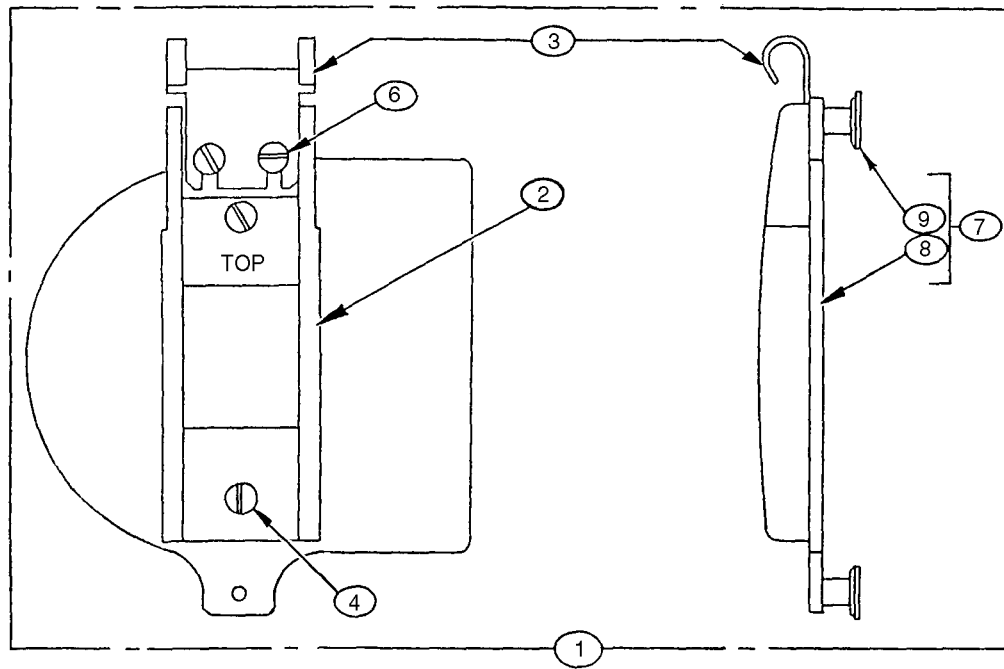

CENTURY "JJ" FILM GATE ASSEMBLIES

<u>Item</u>	<u>Part No.</u>	<u>Description</u>
1	J3-E-20	Film Gate Assembly, 35mm
2	PA-0873	Pressure Pad, 35mm
3	PE-0896	Film Stabilizer Plate
4	SC-1977	Spacer Fastening Screw (2 req'd.)
5	SC-0865	Plate Fastening Screw (2 req'd.)
7	J5-E-41	Plate & Stud Assembly, 35mm
8	PE-0870	Pressure Pad Plate
9	SU-1214	Locating Stud (2 req'd.)
10	J3-E-30	Film Gate Assembly, 70mm
11	PA-0872	Pressure Pad, 70mm
12	PE-1190	Film Stabilizer Plate
13	SC-1956	Spacer Fastening Screw (2 req'd.)
14	SC-0865	Plate Fastening Screw (2 req'd.)
16	J4-E-41	Plate & Stud Assembly, 70mm
17	PE-0869	Pressure Pad Plate
18	SU-1214	Locating Stud (2 req'd.)

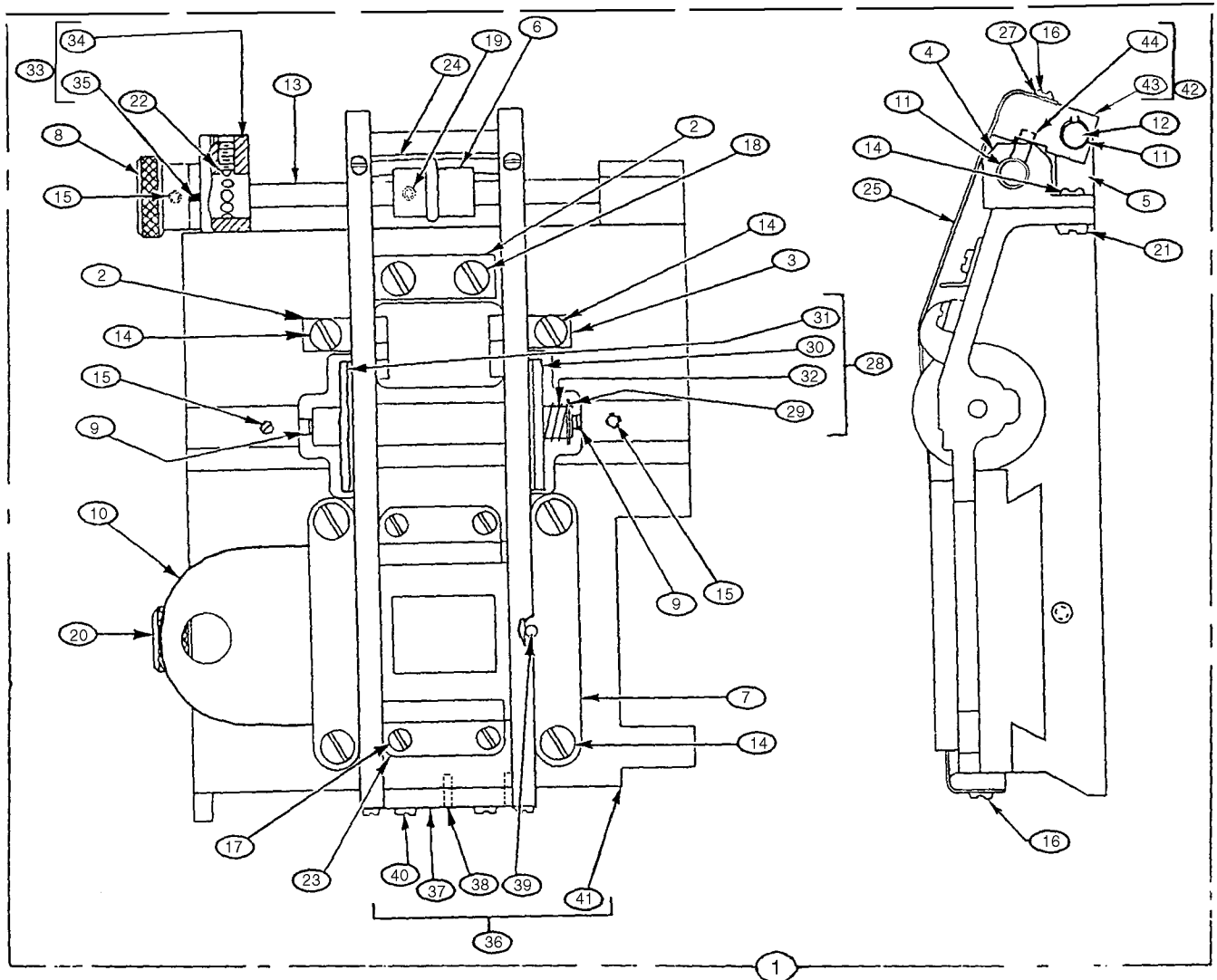

FILM TRAP ASSEMBLY, 35mm
J4-E-50

<u>Item</u>	<u>Part No.</u>	<u>Description</u>
1	J4-E-50	Film Trap Assembly, 35mm (Complete)
2	BR-0943	Trap Shoe Bracket, Outboard
3	BR-0944	Trap Shoe Bracket, Inboard
4	BR-0923	Control Rod Bracket, Inboard
5	BK-0926	Pivot Retaining Block
6	CM-0697	Tensioning Cam
7	GU-0259	Studio Guide (2 req'd.)
8	KN-0069	Tension Adjusting Knob
9	PT-0033	Lateral Guide Roller Pivot (2 req'd.)
10	PE-0518-E4	Aperture Plate (as shown; see Page 71)

FILM TRAP ASSEMBLY, 35mm
Parts List, continued

<u>Item</u>	<u>Part No.</u>	<u>Description</u>
11	RI-0196	Retaining Ring (3 req'd.)
12	RD-0297	Shoe Block Support Rod
13	RD-0298	Control Rod, Tension Cam
14	SC-0054	Mounting Screw (14 req'd.)
15	SC-1094	Retaining Screw
16	SC-0974	Trap Shoe Mounting Screw (4 req'd.)
17	SC-1016	Spring Retaining Screw (4 req'd.)
18	SC-1254	Threading Aperture Retaining Screw (2 req'd.)
19	SC-0579	Cam Fastening Screw
20	SC-1487	Trap Retaining Screw
21	SC-1842	Block Retainng Screw (2 req'd.)
22	SC-2431	Ball Plunger Screw
23	SG-1484	Aperture Plate Retaining Spring
24	SG-2003	Trap Tension Spring
25	SH-1862*	Trap Shoe (Tension Strap), 2 req'd.
26	SD-1986	Threading Aperture
27	WA-0245	Shoe Fastening Lockwasher (2 req'd.)
28	A1-E-12	Lateral Guide Roller Assembly
29	RI-0079	Retaining Ring
30	RO-0283	Inner Lateral Guide Roller
31	RO-0284	Outer Lateral Guide Roller
32	SG-0124	Compression Spring
33	J1-E-51	Control Rod Bracket & Pin Assembly
34	BR-0922	Control Rod Bracket, Front
35	PN-0824	Stop Pin, Knob Adjustment
36	J4-E-52	Trap & Shoe Retaining Block Assembly
37	BK-0929	Shoe Retaining Block, Lower
38	PN-0280	Block Retaining Pin (2 req'd.)
39	PN-0519	Aperture Plate Stop Pin
40	SC-1763	Block Fastening Screw (2 req'd.)
41	TP-0180	Main Plate, Film Trap
42	J4-E-53	Spring Retaining Block & Pin Assembly
43	BK-0927	Spring Retaining Block
44	PN-0963	Spring Retaining Pin

* Replace in *matched pairs*

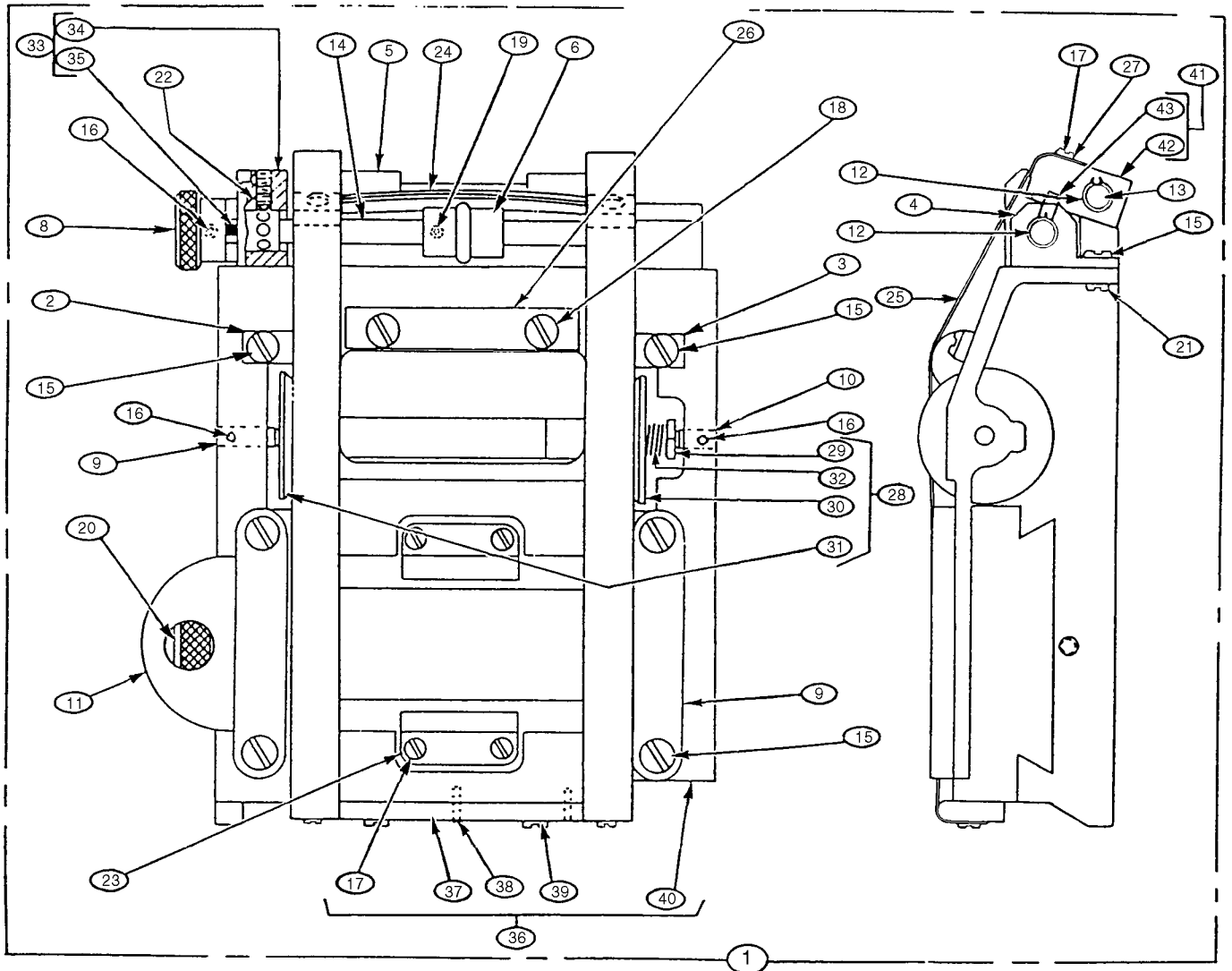

FILM TRAP ASSEMBLY, 70mm
J3-E-50

Item	Part No.	Description
1	J3-E-50	Film Trap Assembly, 70mm (Complete)
2	BR-0945	Trap Shoe Bracket, Outboard
3	BR-0946	Trap Shoe Bracket, Inboard
4	BR-0923	Control Rod Bracket, Inboard
5	BK-0926	Pivot Retaining Block
6	CM-0697	Tensioning Cam
7	GU-0259	Studio Guide (2 req'd.)
8	KN-0069	Tension Adjusting Knob
9	PT-0033	Lateral Guide Roller Pivot, Outboard
10	PT-0718	Lateral Guide Roller Pivot, Inboard

FILM TRAP ASSEMBLY, 70mm
 Parts List, continued

<u>Item</u>	<u>Part No.</u>	<u>Description</u>
11	PE-0719	Aperture Plate (as shown; see Page 71)
12	RI-0196	Retaining Ring (3 req'd.)
13	RD-0273	Shoe Block Support Rod
14	RD-0298	Control Rod, Tension Cam
15	SC-0054	Mounting Screw (14 req'd.)
16	SC-1094	Retaining Screw
17	SC-1016	Spring Retaining Screw (4 req'd.)
18	SC-1254	Threading Aperture Retaining Screw (2 req'd.)
19	SC-0579	Cam Fastening Screw
20	SC-1487	Trap Retaining Screw
21	SC-1842	Block Retainng Screw (2 req'd.)
22	SC-2431	Ball Plunger Screw
23	SG-1484	Aperture Plate Retaining Spring
24	SG-2003	Trap Tension Spring
25	SH-1861*	Trap Shoe (Tension Strap), 2 req'd.
26	SD-1985	Threading Aperture
27	WA-0244	Shoe Fastening Lockwasher (2 req'd.)
28	J1-E-12	Lateral Guide Roller Assembly
29	NU-0012	Guide Roller Nut
30	RO-0231	Inner Lateral Guide Roller
31	RO-0206	Outer Lateral Guide Roller
32	SG-0124	Compression Spring
33	J1-E-51	Control Rod Bracket & Pin Assembly
34	BR-0922	Control Rod Bracket, Front
35	PN-0824	Stop Pin, Knob Adjustment
36	J3-E-52	Trap & Shoe Retaining Block Assembly
37	BK-0864	Shoe Retaining Block, Lower
38	PN-0280	Block Retaining Pin (2 req'd.)
39	SC-0054	Block Retaining Screw (2 req'd.)
40	TP-0179	Main Plate, Film Trap
42	J3-E-54	Spring Retaining Block & Pin Assembly
43	BK-1275	Spring Retaining Block
44	PN-0963	Spring Retaining Pin

* Replace in *matched pairs*

CENTURY "JJ" PROJECTOR
Aperture Plates

for J4-E-50 (35mm) Film Trap:

<u>Part No.</u>	<u>Aspect Ratio</u>	<u>Opening Size</u>
PE-0518-E	1.375:1 (Standard)	.600" x .825"
PE-0518-E1	(Blank)	None
PE-0518-E2	(Pinhole)	Pinhole
PE-0518-E3	2:1 (Wide Screen)	.412" x .825"
PE-0518-E4	1.85:1 (Standard)	.445" x .825"
PE-0518-E5	1.75:1 (Standard)	.470" x .825"
PE-0518-E6	1.66:1 (Standard)	.477" x .800"
PE-0518-E7	1.375:1 (Undersize)	.581" x .703"
PE-0518-E8	1.85/1.75:1 (Undersize)	.420" x .800"
PE-0518-E9	1.66:1 (Undersize)	.477" x .800"
PE-0518-E12	2.35:1 (CinemaScope)	.715" x .825"
PE-0518-E13	2.35:1 (CinemaScope;Undersize)	.675" x .800"
PE-0518-E14	2:1 (CinemaScope)	.715" x .715"
PE-0518-E16	2:1 (CinemaScope; Undersize)	.650" x .650"

for J3-E-50 (70mm) Film Trap:

PE-0719	Standard	.865" x 1.910"
PE-0719-1	Blank	None
PE-0719-2	Undersize	.660" x 1.850"
PE-0719-3	2.21:1 Undersize	.760" x 1.850"
PE-0719-4	Blank with .040" Hole	.040" Hole
PE-0719-5	Blank with 3/8" Hole	.375" Hole

AUTOMATIC APERTURE CHANGER ASSEMBLY
 (used with optional AutoTurret Assembly only)

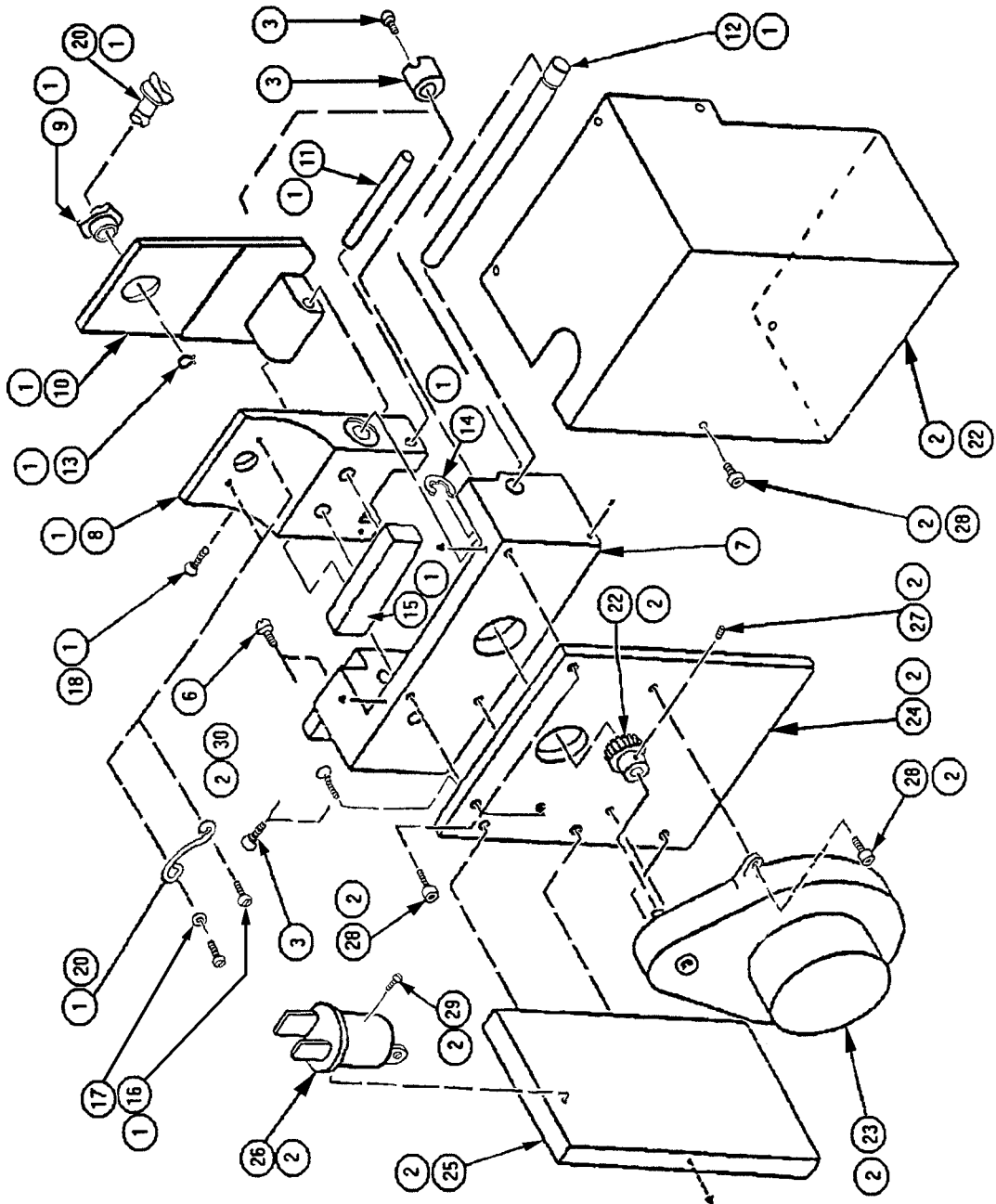

AUTOMATIC APERTURE CHANGER ASSEMBLY (82-60094)

<u>Item</u>	<u>Part No.</u>	<u>Description</u>
1	AC-T-100*	Aperture Carriage Assembly
2	AC-T-120A*	Aperture Motor, Plate & Receptacle Assembly
3	EC-0030	Eccentric Bushing (2 req'd.)
		Aperture Plate PE-1291-E8/15 not shown
5	SC-2117	Screw, 4-40 x 3/8" Socket Head (4 req'd.)
6	P-1757	Screw, 4-40 x 1/4" Socket Head (2 req'd.)
7	SO-2473	Aperture Changer Support
	AC-T-110*	Aperture Carriage Assembly
8	BR-1371	Slider Bracket
9	BU-1366	Bushing
10	CP-0921	Clamp
11	PN-1294	Hinge Pin
12	RD-0626	Carriage Rod
13	RI-0627	Retaining Ring
14	RI-0828	Rod Retaining Ring
15	RK-0562	Rack Gear
16	SC-1638	Spring Mounting Screw, 3-48 x 3/16 Fillister Head (2 req'd.)
17	WA-0379	Washer (2 req'd.)
18	SC-2276	Rack Mounting Screw, 4-40 x 9/16" (2 req'd.) <i>not shown</i>
19	SG-2475	Spring
20	ST-2474	Latching Stud, Quarter-Turn
	SG-2475	Stud Catch Spring
	AC-T-120A*	Aperture Motor, Plate, & Receptacle Assembly
21	CR-0920	Motor Cover
22	GR-0304B	Pinion Gear
23	MO-0114	Motor, DC Drive
24	PE-1292	Motor Plate
25	PE-1293	Plug Plate
26	PG-1128	Plug, Two-Prong Male (as shown; Dual Aperture)
26	81-40018	Plug, Four-Pin Male (not shown; Triple Aperture)
27	SC-0578	Set Screw, 4-40 x 1/8"
28	P-1757	Screw, 4-40 x 1/4" Socket Head (10 req'd.)
29	SC-2234	Screw, 2-56 x 3/4" Round Head
30	81-71032	Motor Wire, Red (not shown; Order by foot)
31	81-71052	Motor Wire, Black (not shown; Order by foot)
32	SC-0865	Screw, 4-40 x 1/8" Round Head (5 req'd.)

* Not Sold as Assembly - Order Individual Components

Associated Parts

9423	Wire Harness Assembly (to Item 26 Plug), Dual Aperture
SF-2270	Socket, (2) Pin
21-71012	Cable, (2) Conductor (Order by foot)
9427	Wire Harness Assembly (to Item 26 Plug), Triple Aperture
81-40038	Socket, (4) Pin
51-71002	Cable, (4) Conductor (Order by foot)

OPTIONAL TURRET ASSEMBLY

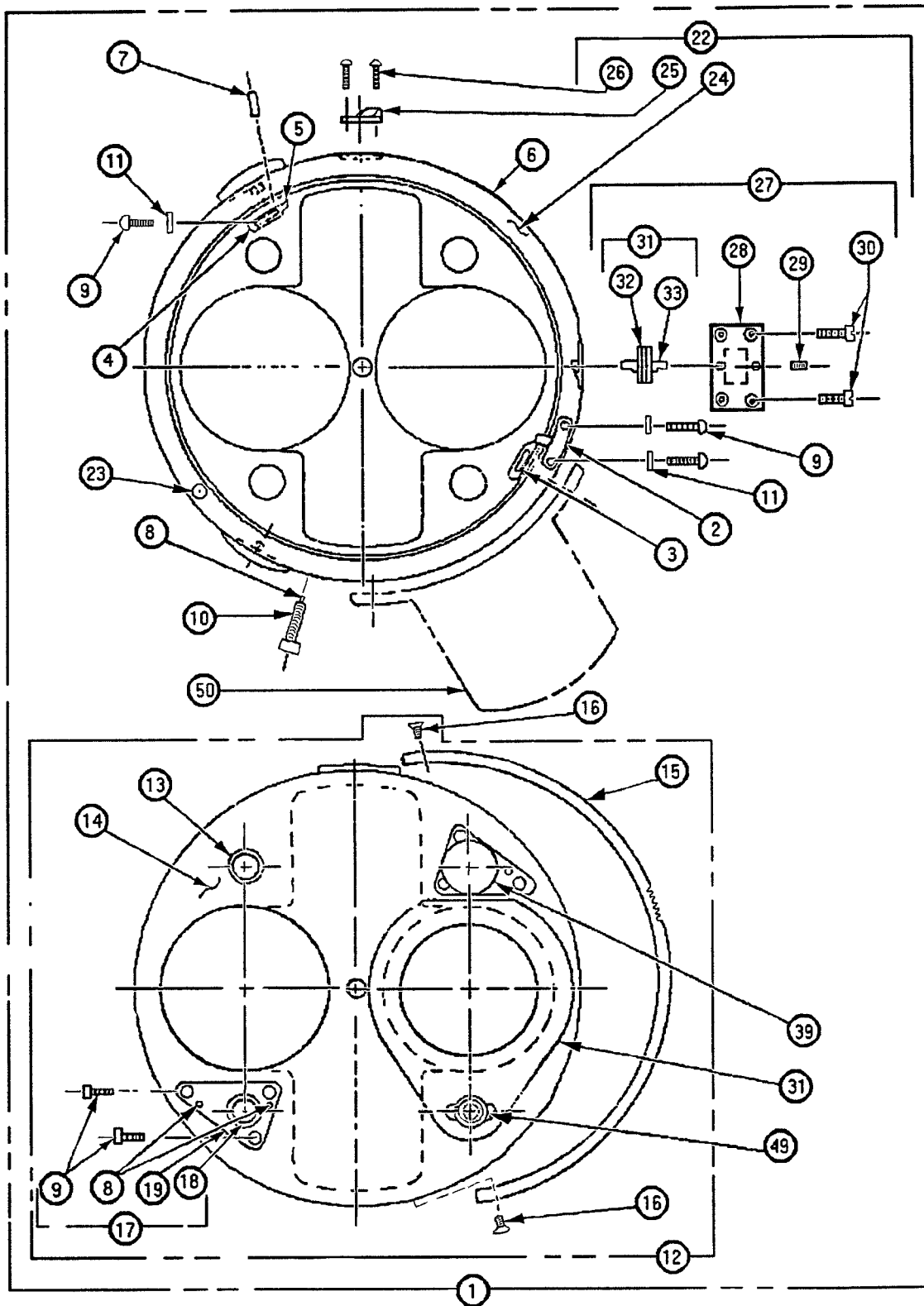

AUTOMATIC TURRET ASSEMBLY (82-60216), Type "TA"

<u>Item</u>	<u>Part No.</u>	<u>Description</u>
1	T1-A-30	Automatic Turret Assembly
	T1-A-31A*	Turret Housing & Bushing
	T1-A-33*	Outer Ring & Bearing
	T1-A-36	Lens Bushing Assembly (2 req'd.)
	T1-A-37	Lens Focus Rod Assembly (2 req'd.)
	T1-A-38	Pivot Rod, Lens Focus (2 req'd.)
2	BP-1318	Adjustable Stop Bumper (2 req'd.)
3	BR-1308	Stop Bracket, Fixed Location
4	BR-1325	Adjustable Locating Stop Bracket
5	BR-1326	Adjustable Location Stop Bracket
6	DC-0141	Decal
7	PG-1264	Lock Screw Plug
8	4402	Locating Pin, 3/16 x 1/2" (2 req'd.)
9	SC-2413	Stop Mounting Screw, 10-32 x 3/4" (4 req'd.)
10	SC-2416	Turret Lock Screw, 1/4-20 x 1" Knurled Head
11	WA-0346	Lockwasher, #10 (4 req'd.)

TURRET HOUSING & BUSHING ASSEMBLY (T1-A-31A*)

<u>Item</u>	<u>Part No.</u>	<u>Description</u>
12	T1-A-31A*	Housing & Bushing Assembly
	T1-A-32	Focus Block & Bushing Assembly
13	BU-1314	Bushing (4 req'd.)
14	HS-0146	Inner Ring Housing
15	RI-0615	Gear Sector (early models)
16	SC-1145	Screw (early models)

FOCUS BLOCK & BUSHING ASSEMBLY (T1-A-32)

<u>Item</u>	<u>Part No.</u>	<u>Description</u>
17	T1-A-32	Block & Bushing Assembly
18	BK-1315	Block
19	BU-1313	Bushing
20	4402	Dowel Pin, 3/16 x 1/2" (2 req'd.)
21	3041	Screw, 10-32 x 3/8" Socket Head (3 req'd.)

* Not Sold as Assembly - Order Individual Components

TURRET RING ASSEMBLY (T1-A-33*)

<u>Item</u>	<u>Part No.</u>	<u>Description</u>
22	T1-A-33*	Turret Ring Assembly
	T1-A-34	Ball Bearing Bracket (3 req'd.)
23	BN-1316	Back Stop Bumper Plug
24	HS-0149	Outer Ring
25	PE-1261	Latch Plate
26	SC-2472	Mounting Screw, 1/4-20 x 3/8" Button Head (2 req'd.)

BALL BEARING & BRACKET ASSEMBLY (T1-A-34*)

<u>Item</u>	<u>Part No.</u>	<u>Description</u>
27	T1-A-34*	Bearing & Bracket Assembly
	T1-A-35	Shaft & Bearing
28	BR-1312	Bearing Bracket
29	SC-0673	Adjustment Screw (2 req'd.)
30	41-51208	Mounting Screw, 10-32 x 1/2" Socket Head (4 req'd.)

BEARING & SHAFT ASSEMBLY (82-60149)

<u>Item</u>	<u>Part No.</u>	<u>Description</u>
31	T1-A-35*	Bearing & Shaft Assembly (<i>Sold as Assembly only</i>)
32	BG-1260A	Ball Bearing (3 req'd.)
33	RD-0609	Rod

* Not Sold as Assembly - Order Individual Components

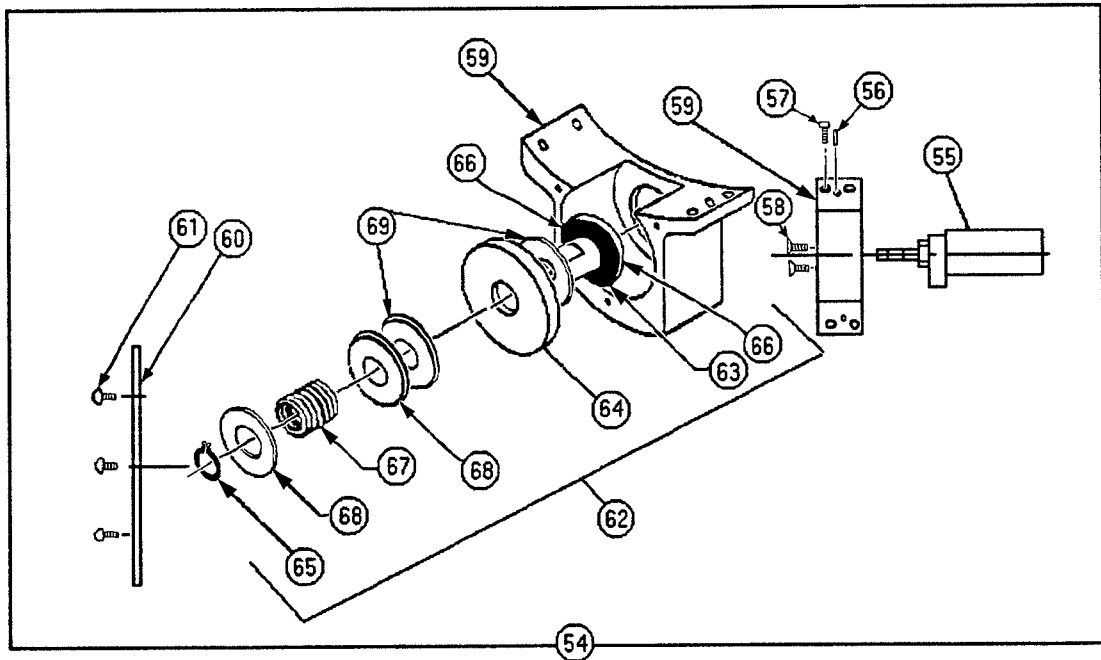
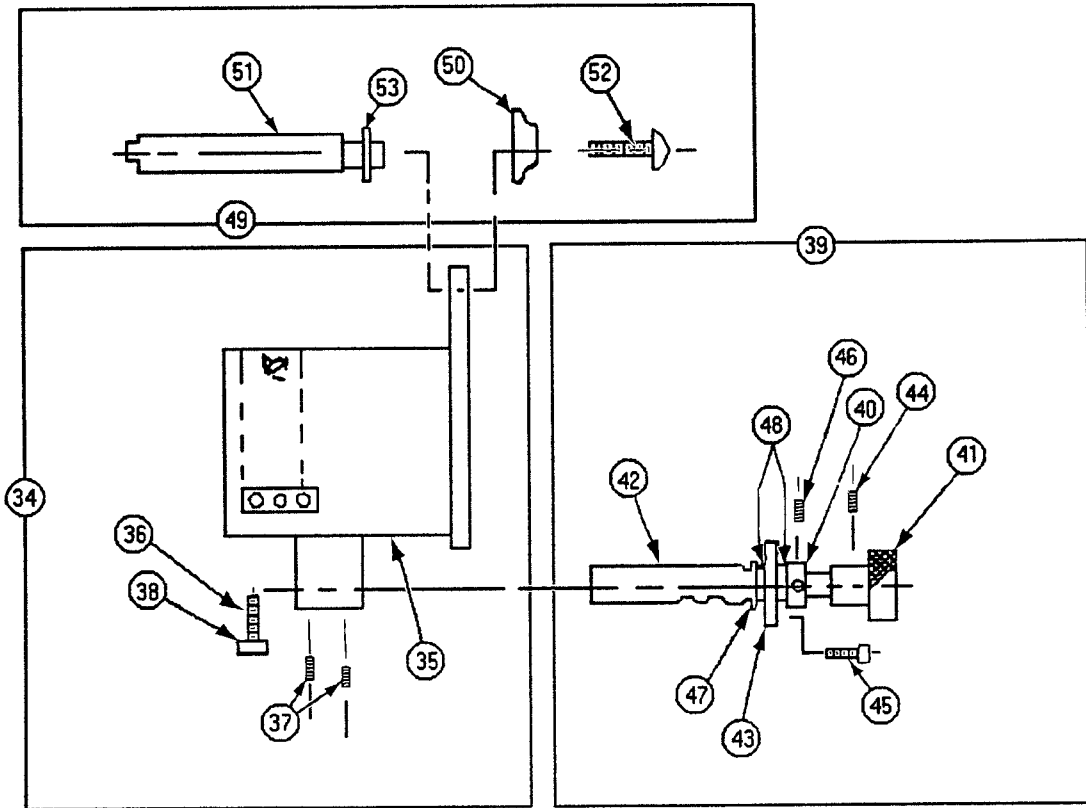

LENS BUSHING ASSEMBLY

<u>Item</u>	<u>Part No.</u>	<u>Description</u>
34	T1-A-*36	Lens Bushing Assembly
35	BU-1305	Bushing, Lens Holder
36	PG-1264	Screw Plug
37	SC-0905	Focus Rod Set Screw, 1/4-20 x 1/4" (2 req'd.)
38	SC-2498	Lens Clamping Screw

LENS FOCUS ROD ASSEMBLY

<u>Item</u>	<u>Part No.</u>	<u>Description</u>
39	T1-A-37A	Focus Rod Assembly
40	CL-0554	Focus Collar
41	KN-0045	Knob
42	RD-0610	Focus Rod (Order T1-A-37A)
43	SA-1226	Spacer
44	41-51180	Knob Set Screw, 10-32 x 3/8"
45	SC-0105	Mounting Screw, 4-40 x 1/4" Fillister Head (3 req'd.)
46	SC-1236	Collar Set Screw, 10-32 x 3/16" (2 req'd.)
47	SC-1362	Focus Screw
48	WA-0163	Focus Washer

LENS FOCUS PIVOT ROD ASSEMBLY (T1-A-38*)

<u>Item</u>	<u>Part No.</u>	<u>Description</u>
49	T1-A-38*	Pivot Rod Assembly
50	CL-0866	Collar
51	RD-0611	Rod (Order T1-A-38)
52	41-51564	Fastening Screw, 10-32 x 1/2" Socket Head
53	WA-0135	Washer

* Not Sold as Assembly - Order Individual Components

TURRET MOTOR & BRACKET ASSEMBLY (T1-A-60), Type "TA" Turret

<u>Item</u>	<u>Part No.</u>	<u>Description</u>
54	T1-A-60	Turret Motor & Bracket Assembly
	T1-A-42	Bracket Housing
	T1-A-59	Gear & Clutch Assembly
55	MO-0134	Motor
56	PN-0786	Locating Pin (2 req'd.)
57	3069	Bracket Mounting Screw, 1/4-20 x 5/8" (4 req'd.)
58	SC-2414	Motor Mounting Screw, 10-32 x 1/2" (4 req'd.)
59	BR-1306*	Housing Bracket
60	PE-1263*	Bracket Cover (81-29011)
61	SC-2415*	Plate Screw (3 req'd.)

* Order T1-A-60

GEAR & SLIP CLUTCH for AUTOMATIC TURRET MOTOR (T1-A-59)

<u>Item</u>	<u>Part No.</u>	<u>Description</u>
62	T1-A-59	Gear & Slip Clutch
63	FL-0189	Flange
64	GR-0332	Gear
65	RI-0643	Retaining Ring
66	SC-0673	Flange Set Screw, 8-32 x 3/8" (2 req'd.)
67	SG-2492	Compression Spring
68	WA-0382	Brake Washer (2 req'd.)
69	WA-0342	Brake Washer (2 req'd.)

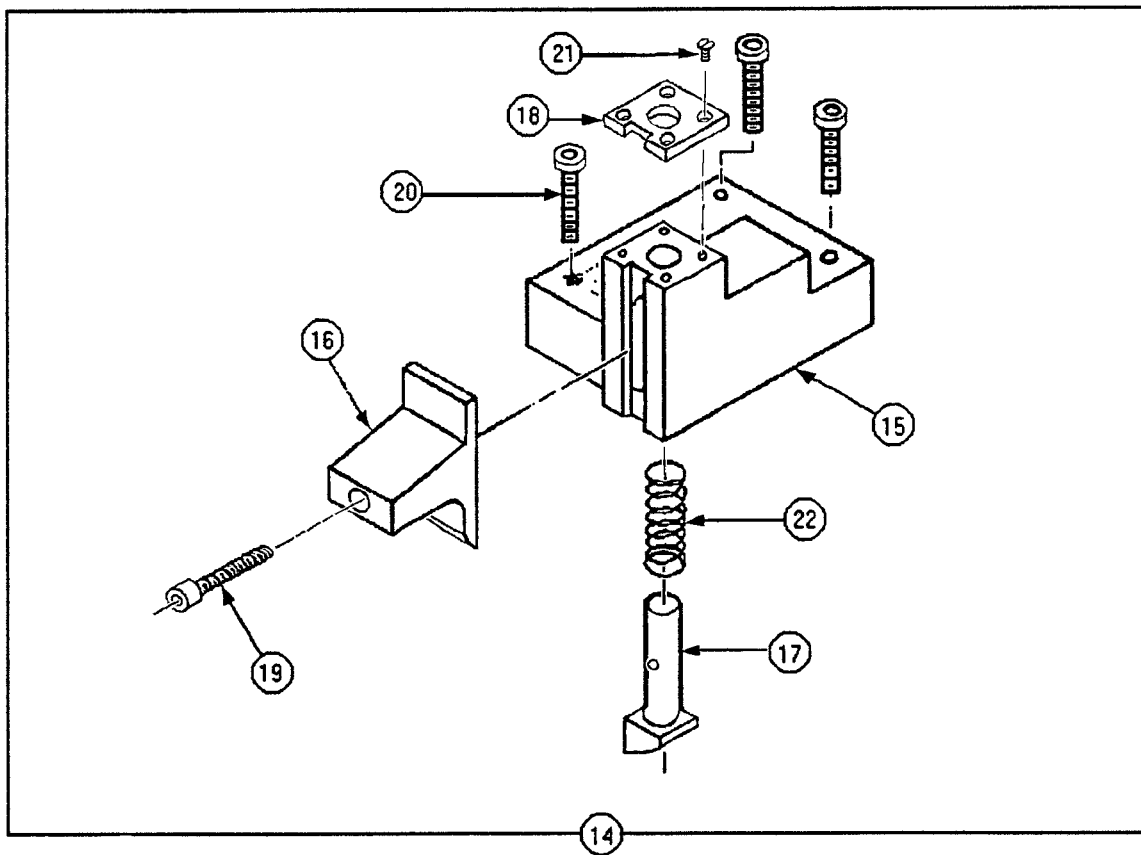
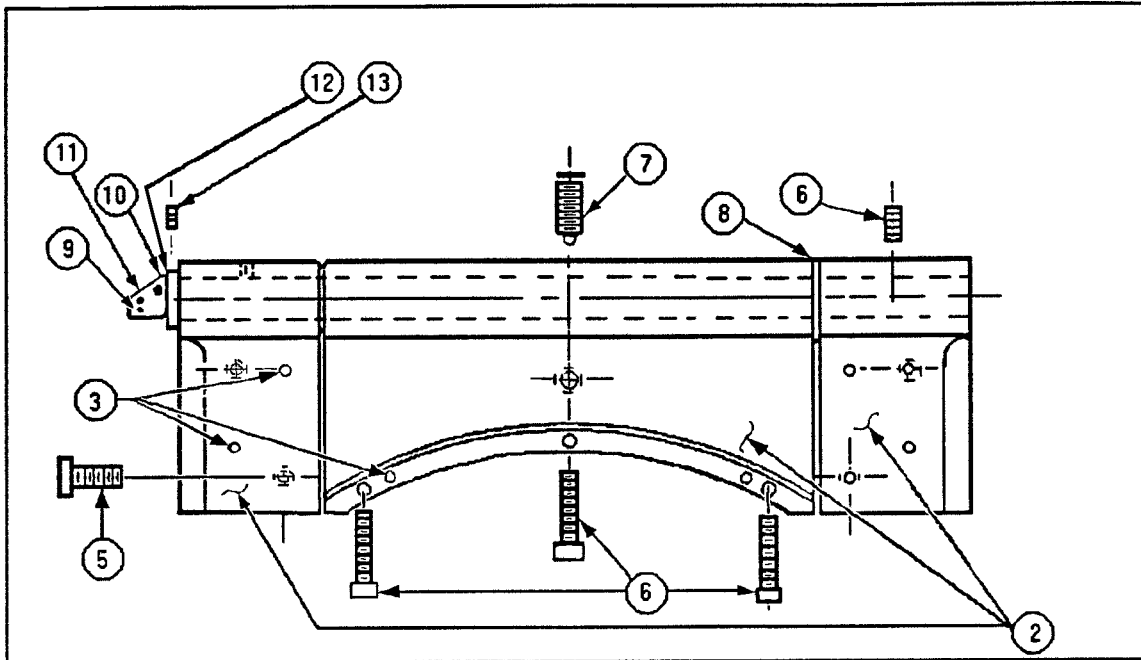

TURRET MOUNTING HINGE ASSEMBLY (82-60208)

<u>Item</u>	<u>Part No.</u>	<u>Description</u>
1	T1-A-11	Turret Hinge Assembly
	T1-A-12*	Hinge Pin
2	T1-A-13	Hinge Bracket (Order T1-A-11)
3	PN-0786	Mounting Pin (6 req'd.)
4	3052	Lock Set Screw, 1/4-20 x 3/8" (2 req'd.)
5	SC-1689	Bracket Mounting Screw, 1/4-20 x 3/8" (4 req'd.)
6	2982	Turret Mounting Screw, 10-32 x 1-1/4" (3 req'd.)
7	SC-2436	Bumper Screw, 1/2-13 x 3/4"
8	WA-0349	Bearing Washer
9	BR-1333	Upper Stop Bracket
10	BR-1334	Lower Stop Bracket
11	SC-2472	Fastening Screw (4 req'd.)

TURRET HINGE PIN ASSEMBLY (T1-A-12*)

<u>Item</u>	<u>Part No.</u>	<u>Description</u>
	T1-A-12*	Hinge Pin
12	FT-0185	Grease Fitting
	PN-1260	Pin (Order T1-A-12*)
13	SC-0585	Set Screw, 10-32 x 3/16" (2 req'd.)

* Not Sold as Assembly - Order Individual Components

TURRET TOP LOCK ASSEMBLY (T1-A-20)

<u>Item</u>	<u>Part No.</u>	<u>Description</u>
14	T1-A-20	Turret Top Lock
15	BK-1309	Housing Block
16	LA-0116	Latch
17	LO-0115	Lock Pin
18	PE-1259	Retaining Plate
19	SC-1045	Fastening Screw, 8-32 x 1" Socket Head
20	41-51208	Block Screw, 10-32 x 1/2" Socket Head (3 req'd.)
21	41-51591	Plate Screw, 6-32 x 3/8" Flat Head (4 req'd.)
22	SG-2403	Lock Spring

MODIFIED PARTS for THREE-LENS TYPE "TA" TURRET (82-60076)

<u>Part No.</u>	<u>Description</u>
8614	Focus Rod Bushing (ref. Page 74, Item 19); 3 req'd.
8615	Lens Bushing (ref. Page 74, Item 35); 3 req'd.
8616	Inner Ring (ref. Page 74, Item 14)
9451	Turret Gear, Aluminum
8629	Outer Ring Housing (ref. Page 74, Item 24)
T1-A-40	Turret Motor & Bracket Assembly (ref. Page 74, Item 54)
MO-0107	Motor (ref. Page 74, Item 55)
9425	Tubular Solenoid Assembly, Index Stop
81-55001	Solenoid
51-17001	Diode, 1N4077
21-40011	Molex Plug
21-62036	Molex Pin (2 req'd.)
8627	Solenoid Pin, 1/2" Hardened Steel
8625	Solenoid Mounting Block
8620	Catch, Solenoid Pin (3 req'd.)

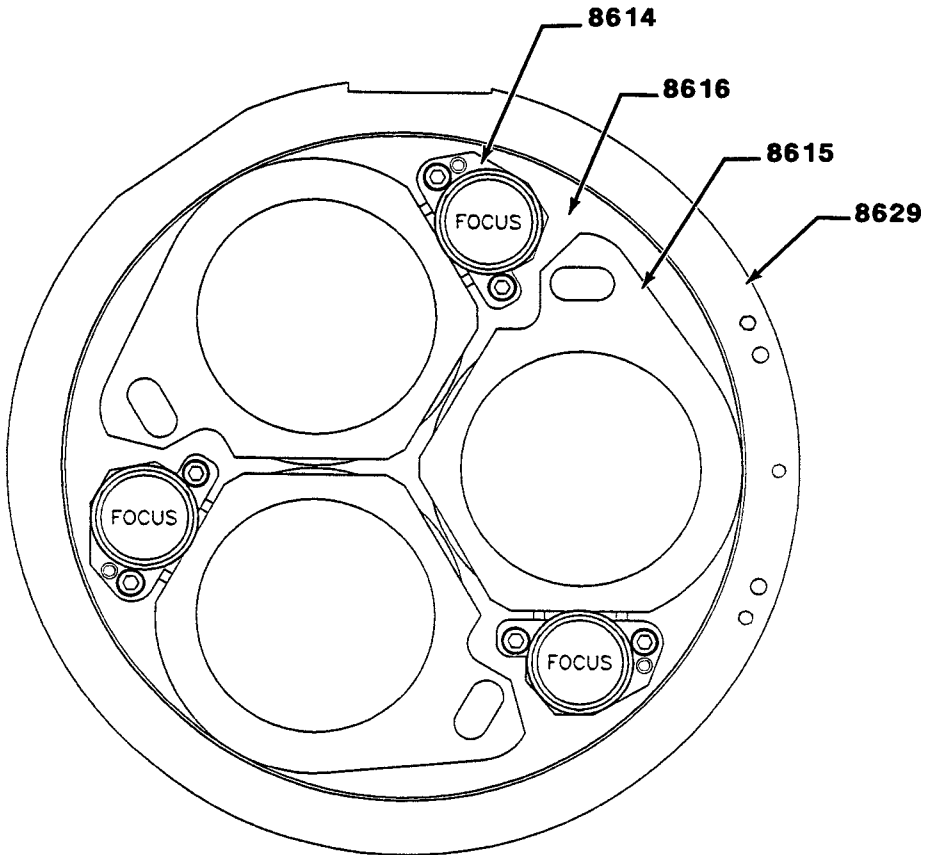

R31-E MAGNETIC SOUNDHEAD

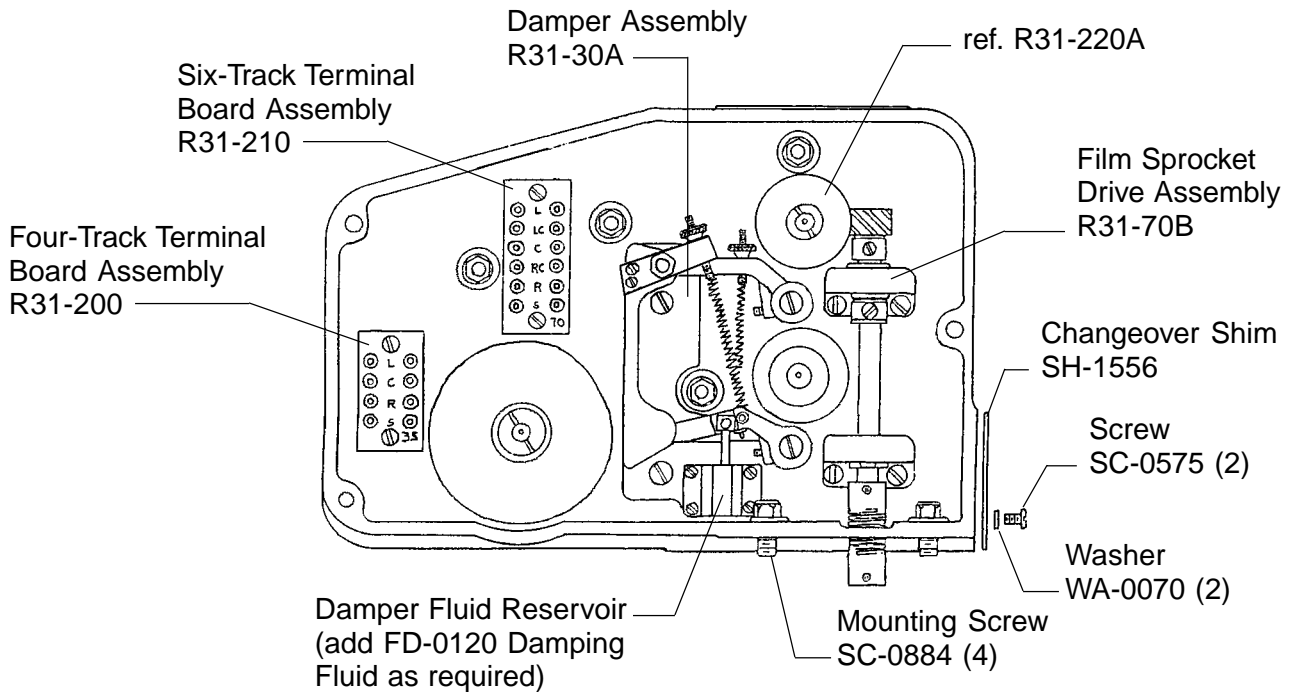
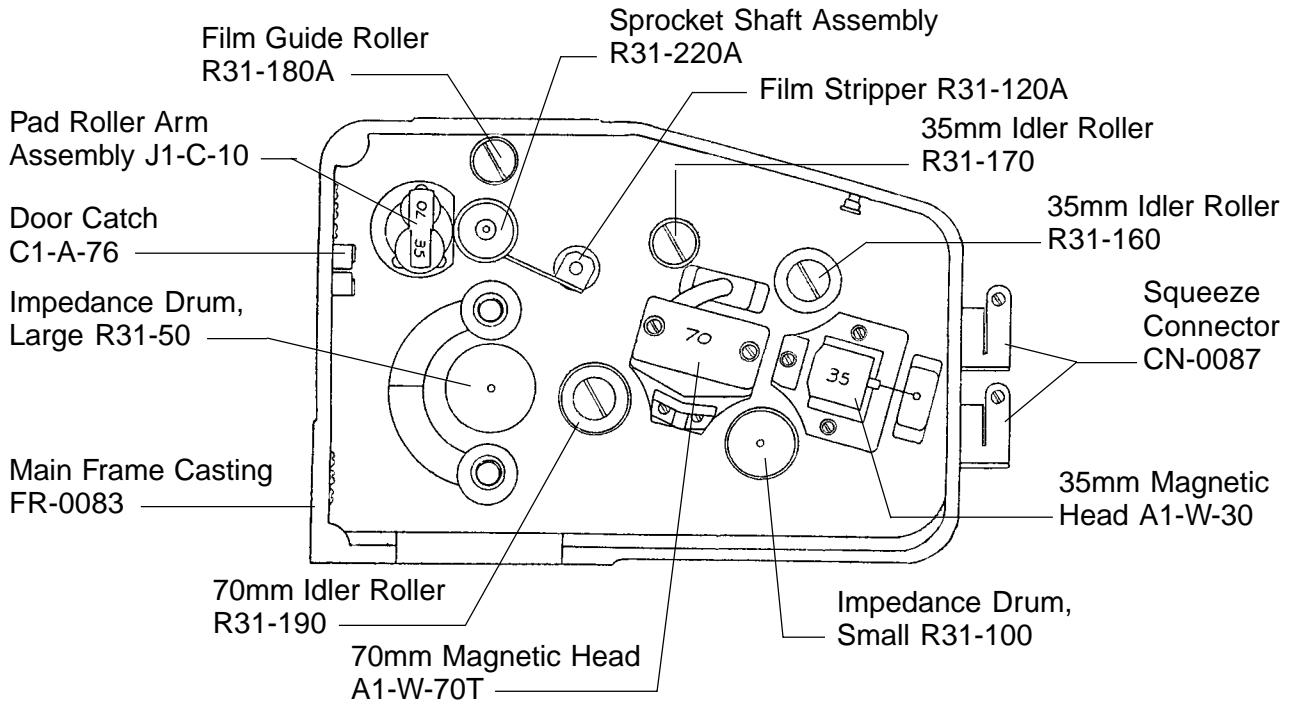

R31-E PENTHOUSE, Major Assemblies

<u>Part No.</u>	<u>Description</u>
A1-W-30	Magnetic Head Assembly, Four-Track (35mm)
A1-A-70T	Magnetic Head Assembly, Six-Track (70mm)
SC-0081	Mounting Screw (4 req'd.)
C1-A-11	Door Hinge & Pin Assembly
SC-0070	Mounting Screw (6 req'd.)
C1-A-76	Door Catch Assembly
SC-0565	Mounting Screw (2) req'd.)
J1-C-10	Pad Roller Arm Assembly
R31-50	Large Impedance Drum Assembly
R31-100	Small Impedance Drum Assembly
R31-120A	Film Stripper Assembly
R31-160	Large Film Idler Assembly, 35mm
R31-170	Small Film Idler Assembly, 35mm
R31-180A	Film Guide Roller Assembly, 35/70mm
R31-190	Film Idler Assembly, 70mm
R31-220A	Sprocket Shaft Assembly
CN-0087	Squeeze Connector (2 req'd.)
SC-0226	Screw, Door Stop Link
R31-30A	Damper Assembly
R31-70B	Vertical Drive Shaft Assembly
R31-200	Terminal Board Assembly, Four-Track (35mm)
R31-210	Terminal Board Assembly, Six-Track (70mm)

R31-30A DAMPER ASSEMBLY

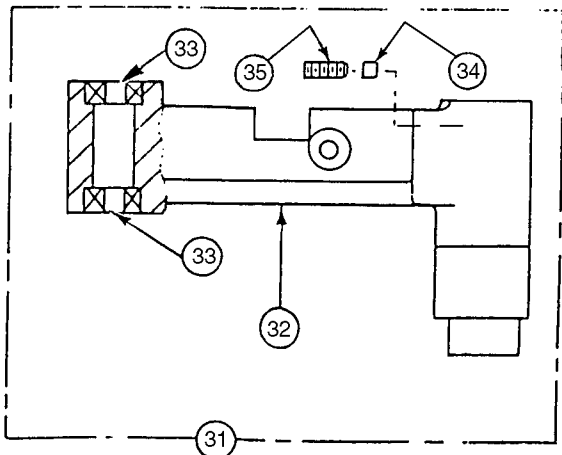
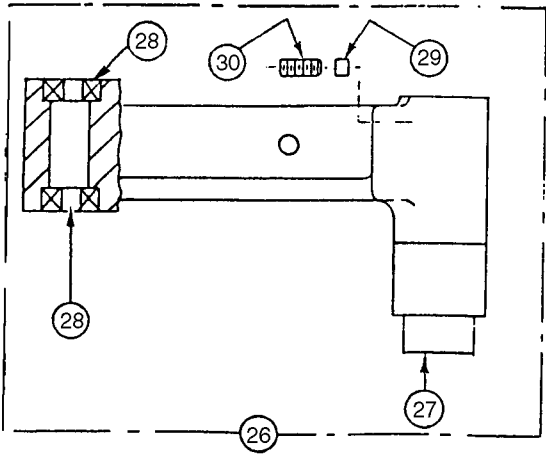
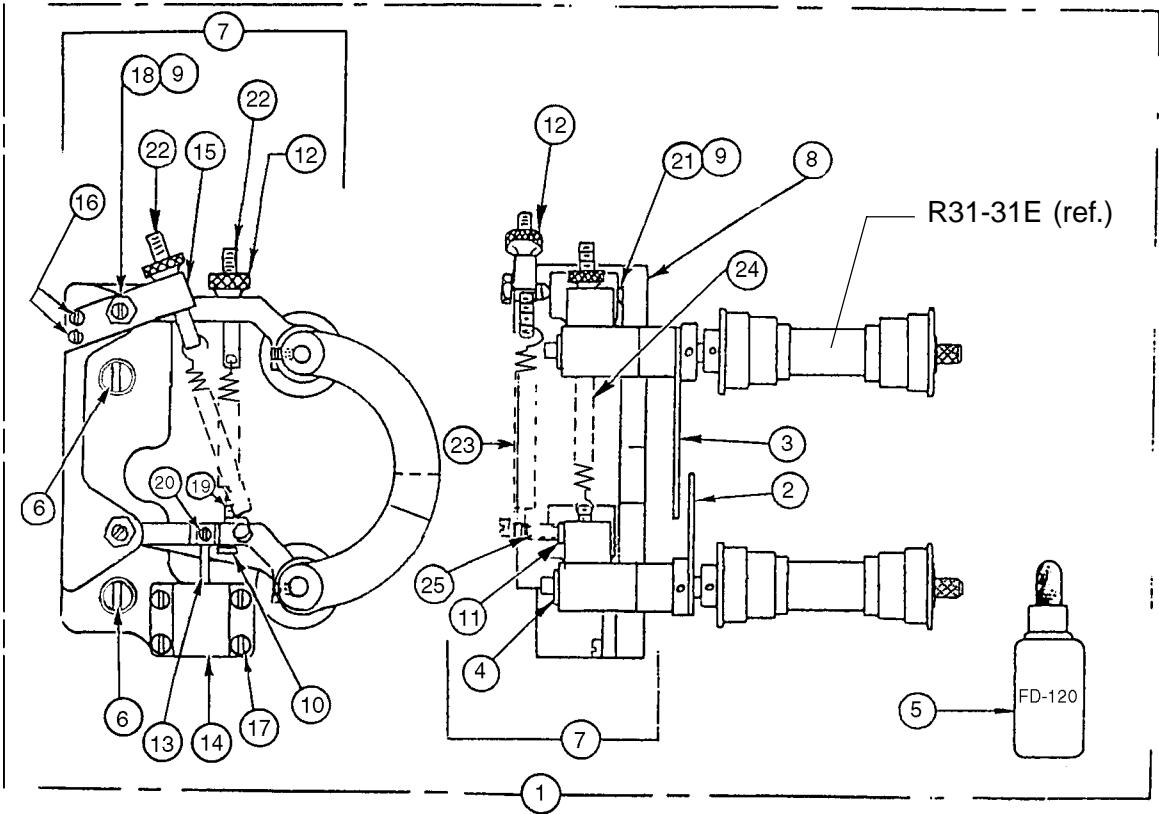

R31-30A DAMPER ASSEMBLY Parts List

<u>Item</u>	<u>Part No.</u>	<u>Description</u>
1	R31-30A	Damper Assembly (Complete)
	R31-31E	Damper Roller & Shaft (2 req'd.)
2	R31-36	Lower Indicating Plate & Collar
3	R31-37	Upper Indicating Plate & Collar
4	RI-0550	Retaining Ring
5	FC-0120	Damping Fluid
6	SC-0137	Damper Mounting Screw (2 req'd.)
7	R31-35E	Damper Bracket & Arms Assembly
8	BR-0722	Damper Bracket
9	NU-0033	Pivot Screw Retaining Nut (4 req'd.)
10	NU-0094	Nut, Spring Screw
11	NU-0073	Damper Spring Stud Nut
12	NU-0083	Adjusting Screw Nut
13	PU-0733	Damper Plunger
14	RT-0221	Damper Fluid Reservoir
15	RT-0240	Damper Spring Retainer
16	SC-0083	Retainer Fastening Screw
17	SC-0088	Retainer Fastening Screw
18	SC-0282	Pivot Arm Screw, Long (2 req'd.)
19	SC-0519	Spring Adjusting Screw, Short
20	SC-0550	Plunger Pivot Screw
21	SC-0551	Pivot Arm Screw, Short (2 req'd.)
22	SC-1587	Spring Adjusting Screw, Long (2 req'd.)
23	SG-1588	Damper Spring
24	SG-1589	Auxiliary Damper Spring
25	SU-1586	Damper Spring Stud
26	R31-33E	Upper Damper Arm Assembly
27	AR-0190	Upper Arm Casting
28	BG-1220	Ball Bearing (2 req'd.)
29	PG-0013	Fibre Plug
30	SC-0981	Shaft Locating Screw
31	R31-34E	Lower Damper Arm Assembly
32	AR-0191	Lower Arm Casting
33	BG-1220	Ball Bearing (2 req'd.)
34	PG-0301	Fibre Plug
35	SC-0981	Shaft Locating Screw

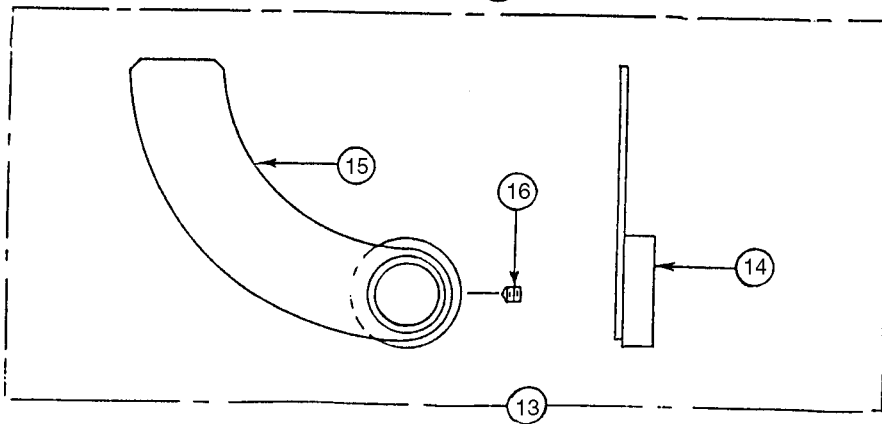
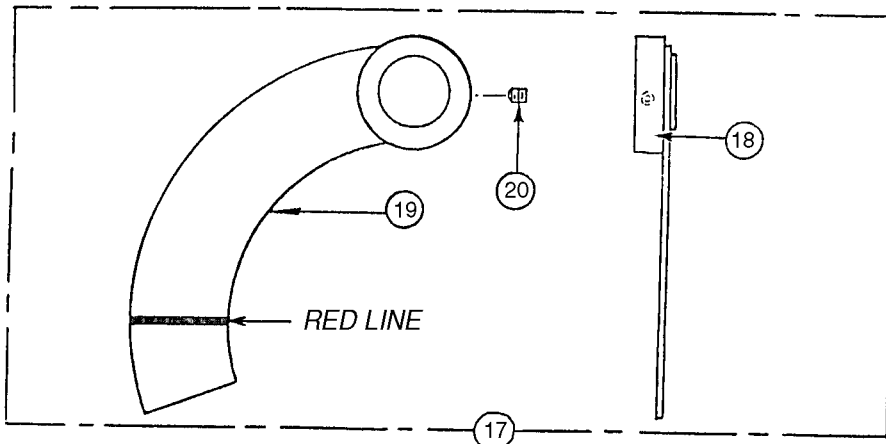
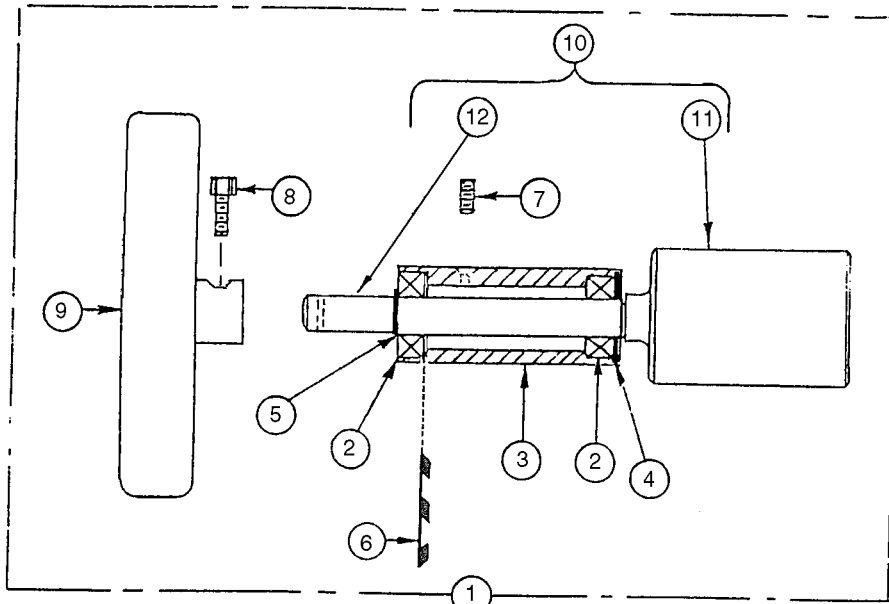

PARTS LIST, Preceding Page

<u>Item</u>	<u>Part No.</u>	<u>Description</u>
1	R31-50	Large Impedance Drum Assembly (Complete)
2	BG-0726	Ball Bearing (2 req'd.)
3	BU-0724	Bushing
4	RI-0089	Internal Retaining Ring
5	RI-0090	External Retaining Ring
6	SG-0943	Loading Spring
7	SC-0155	Bushing Fastening Screw
8	SC-0681	Flywheel Fastening Screw
9	WH-0205	Flywheel
10	R31-51	Impedance Drum Assembly
11	DR-0077	Drum
12	ST-1506	Shaft
13	R31-36	Lower Indicating Plate Assembly
14	CL-0618	Collar
15	PE-0735	Plate
16	SC-1235	Set Screw
17	R31-37	Upper Indicating Plate Assembly
18	CL-0618	Collar
19	PE-0734	Plate
20	SC-1235	Set Screw

PARTS LIST, Facing Page

<u>Item</u>	<u>Part No.</u>	<u>Description</u>
1	R31-31E	Damper Roller & Shaft Assembly
2	BG-0259	Ball Bearing
3	CL-0617	Thrust Collar
4	RO-0212	Roller
5	SC-1235	Set Screw
6	R31-32E	Damper Shaft & Ring Assembly
7	RI-0572	Retaining Ring
8	ST-2247	Roller Shaft
9	R31-120A	Film Stripper Assembly
10	PE-0762	Stripper Plate
11	SU-1537	Stud

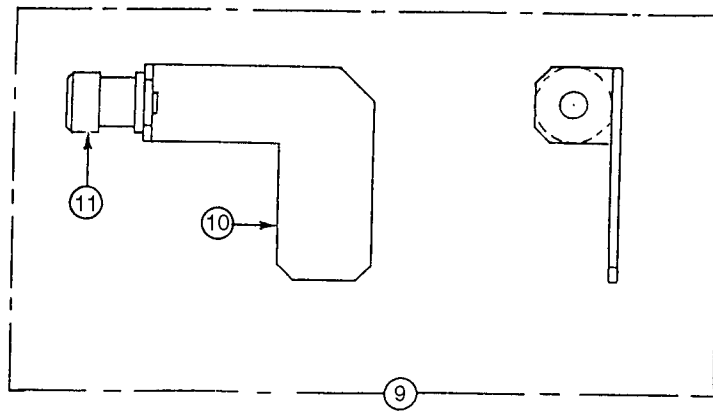
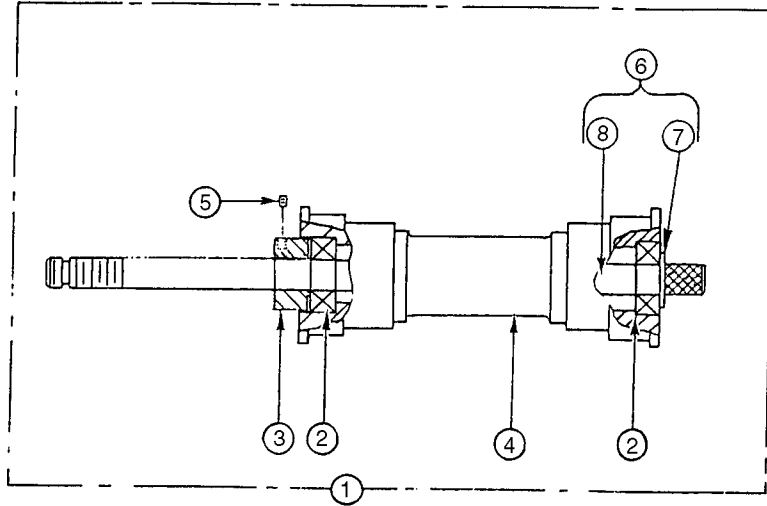

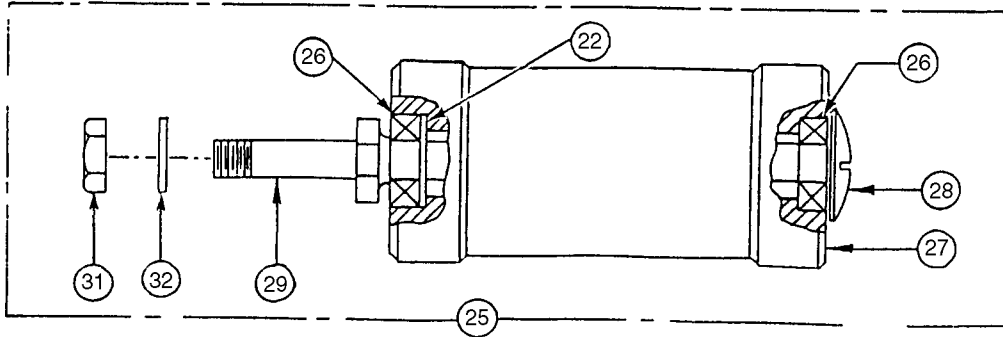
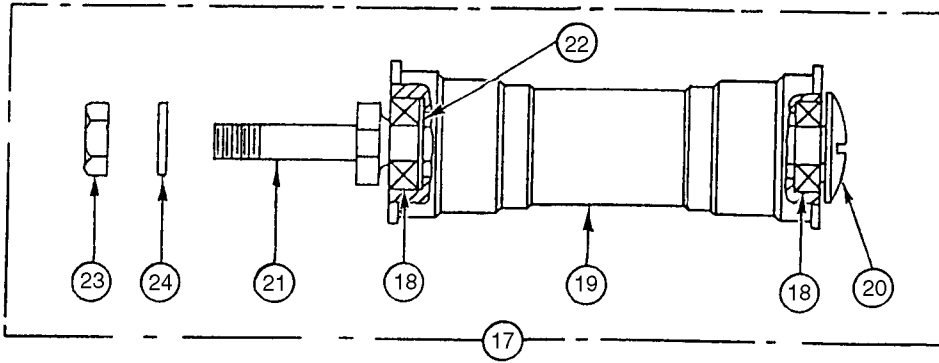
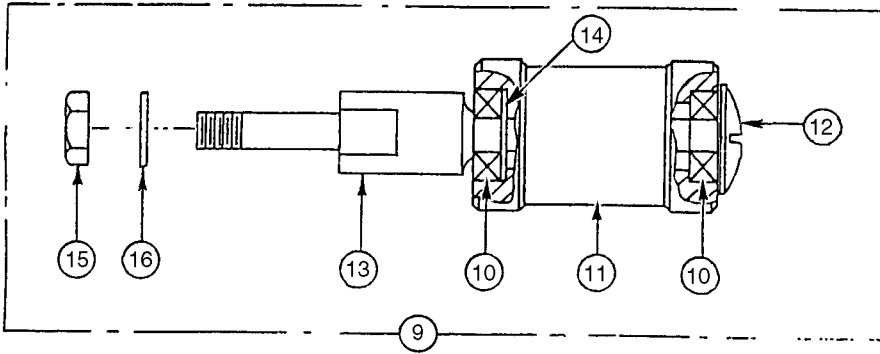
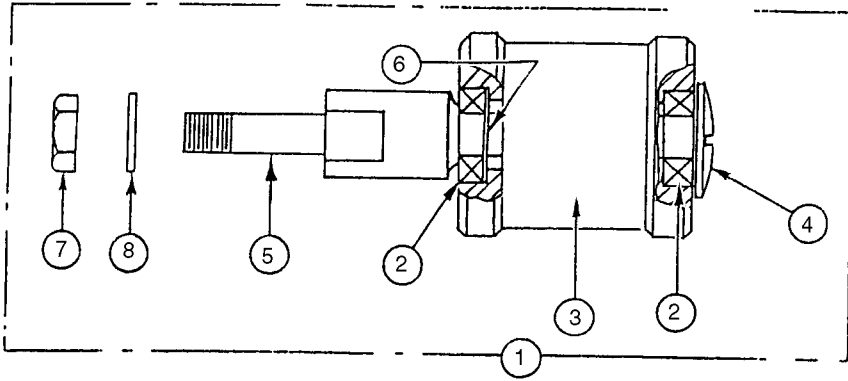

R31-E ROLLER ASSEMBLIES

<u>Item</u>	<u>Part No.</u>	<u>Description</u>
1	R31-160	Large 35mm Idler Roller Assembly
2	BG-0239	Ball Bearing (2 req'd.)
3	RO-0223	Idler Roller, 35mm
4	SC-1233	Bearing Retaining Screw
5	SU-1516	Roller Stud
6	WA-0200	Spring Washer
7	NU-0007	Nut, Roller Stud
8	WA-0077	Washer
9	R31-170	Small 35mm Idler Roller Assembly
10	BG-0259	Ball Bearing (2 req'd.)
11	RO-0222	Idler Roller, 35mm
12	SC-1233	Bearing Retaining Screw
13	SU-1516	Roller Stud
14	WA-0200	Spring Washer
15	NU-0007	Nut, Roller Stud
16	WA-0077	Washer
17	R31-180A	Upper Film Guide Roller Assembly
18	BG-0259	Ball Bearing (2 req'd.)
19	RO-0239	Roller, 35/70mm
20	SC-1233	Bearing Retaining Screw
21	SU-1517	Roller Stud
22	WA-0200	Spring Washer
23	NU-0007	Nut, Roller Stud
24	WA-0077	Washer
25	R31-190	Film Idler Roller Assembly, 70mm
26	BG-0259	Ball Bearing (2 req'd.)
27	RO-0225	Idler Roller, 70mm
28	SC-1233	Bearing Retaining Screw
29	SU-1517	Roller Stud
30	WA-0200	Spring Washer
31	NU-0007	Nut, Roller Stud
32	WA-0077	Washer

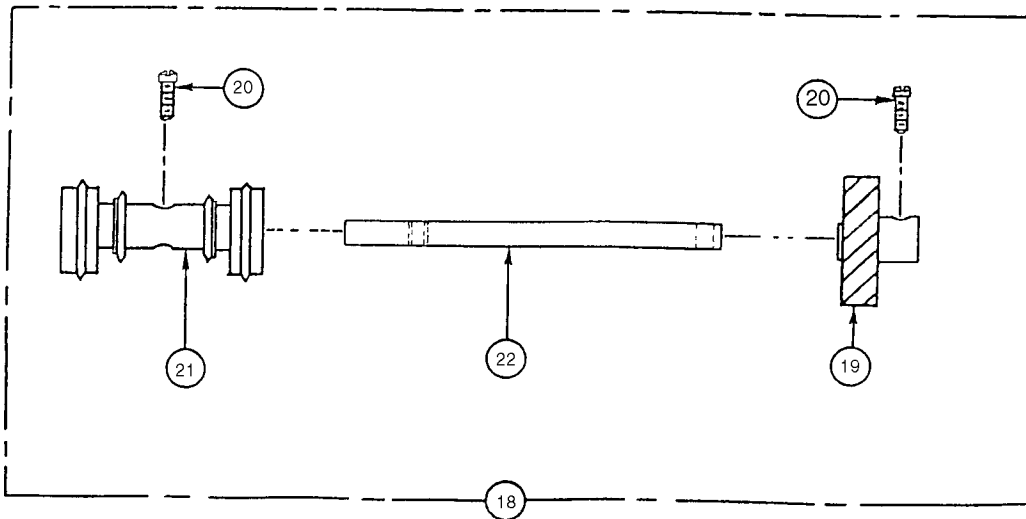
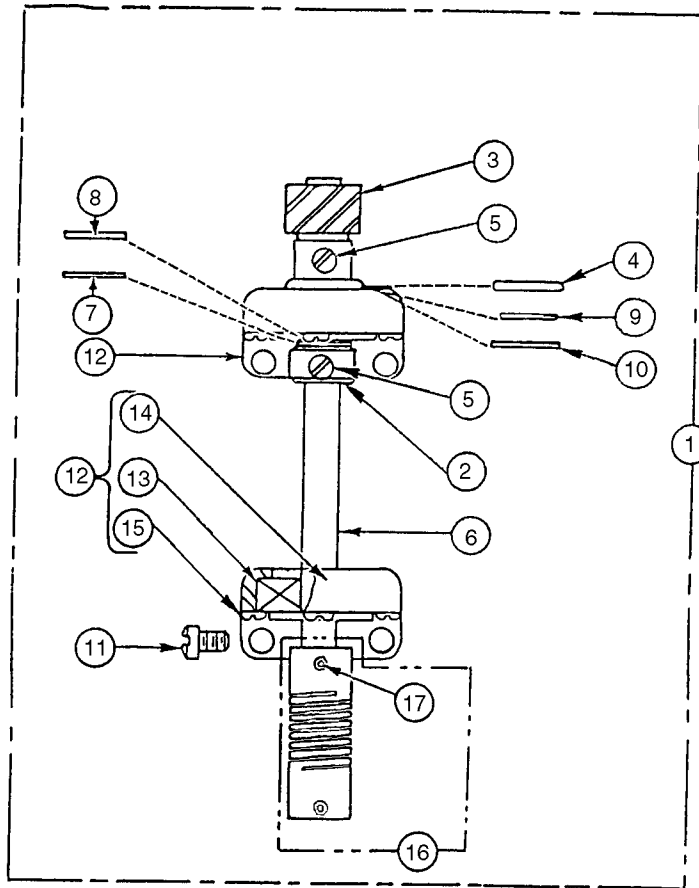

R31-E SHAFT ASSEMBLIES

<u>Item</u>	<u>Part No.</u>	<u>Description</u>
1	R31-70B	Vertical Drive Shaft Assembly
2	CL-0013	Thrust Collar
3	GR-0133	Sprocket Drive Gear
4	RT-0061	Thrust Washer Retainer
5	SC-0081	Fastening Screw (5 req'd.)
6	ST-1974	Sprocket Drive Shaft
7	WA-0003	Fibre Thrust Washer
8	WA-0010	Steel Thrust Washer
9	WA-0130	Neoprene Thrust Washer
10	WA-0131	Steel Thrust Washer
11	SC-0143	Fastening Screw (4 req'd.)
12	C1-G-31	Ball Bearing Bracket Assembly
13	BG-0009	Ball Bearing
14	BR-0020	Bearing Bracket, Cast
15	SC-0127	Bearing Retaining Screw (3 req'd.)
16	R31-73	Flexible Coupling Assembly
17	SC-0585	Fastening Screw (4 req'd.)
18	R31-220A	Sprocket Shaft Assembly
19	GR-0132	Sprocket Shaft Driven Gear
20	SC-1190	Fastening Screw (2 req'd.)
21	SK-1529	Film Sprocket, 35/70mm
22	ST-1481	Sprocket Shaft

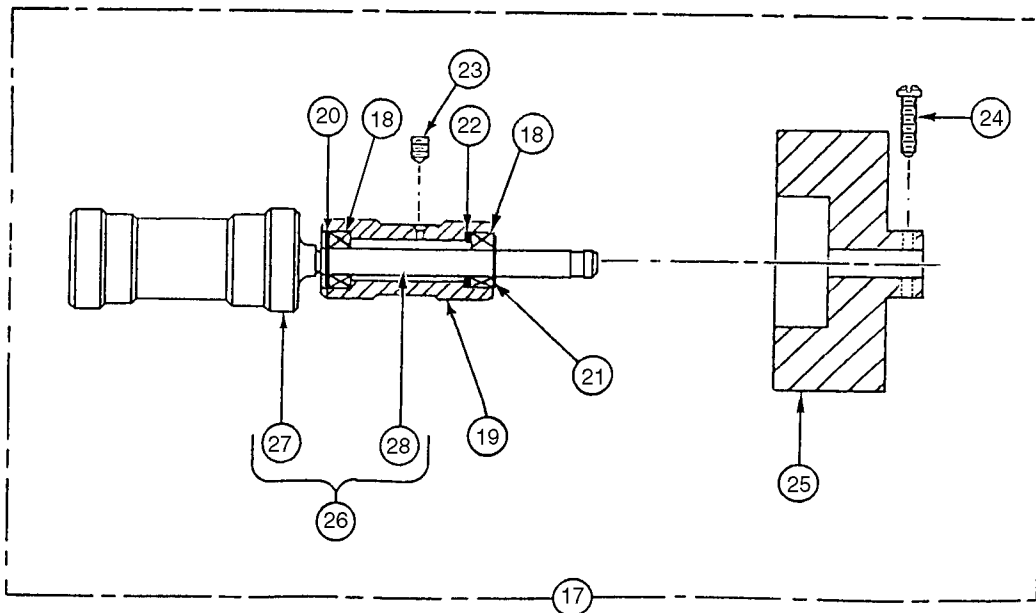
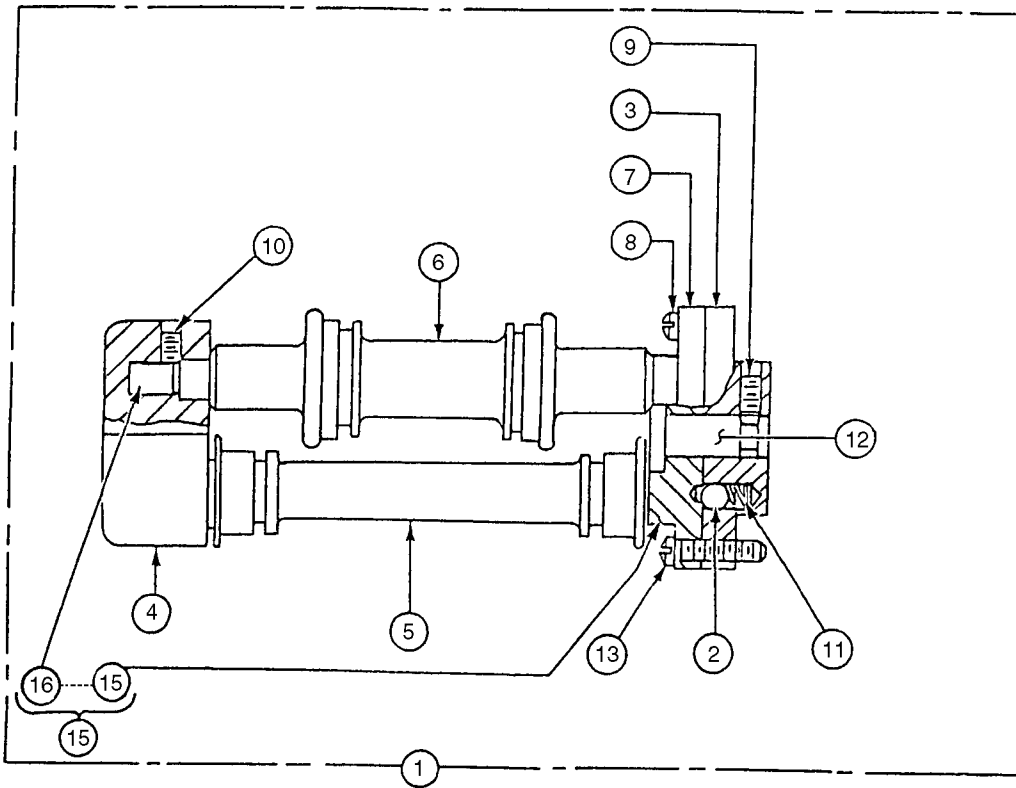

PAD ROLLER ARM ASSEMBLY

<u>Item</u>	<u>Part No.</u>	<u>Description</u>
1	J1-C-10	Pad Roller Arm Assembly
2	BL-0018	Steel Ball (2 req'd.)
3	BU-0714	Pad Roller Bushing
4	KN-0058	Pad Roller Knob
5	RO-0209	Pad Roller, 70mm
6	RO-0210	Pad Roller, 35mm
7	RT-0211	Bushing Retainer
8	SC-0088	Fastening Screw (3 req'd.)
9	SC-0873	Fastening Screw (2 req'd.)
10	SC-0882	Knob Fastening Screw (2 req'd.)
11	SG-1230	Roller Arm Spring (2 req'd.)
12	SU-1490	Arm Stud
13	SC-1492	Fastening Screw (3 req'd.)
14	J1-C-11	Stud & Retaining Plate Assembly
15	PE-0722	Retaining Plate
16	SU-1491	Stud (2 req'd.)

SMALL IMPEDANCE DRUM ASSEMBLY

<u>Item</u>	<u>Part No.</u>	<u>Description</u>
17	R31-100	Small Impedance Drum Assembly
18	BG-0723	Ball Bearing (2 req'd.)
19	BU-0725	Bushing
20	RI-0217	Internal Retaining Ring
21	RI-0218	External Retaining Ring
22	SG-1507	Loading Spring
23	SC-0155	Bushing Fastening Screw
24	SC-0915	Flywheel Fastening Screw
25	WH-0206	Flywheel
26	R31-101	Impedance Drum Assembly
27	DR-0076	Impedance Drum
28	ST-1519	Shaft

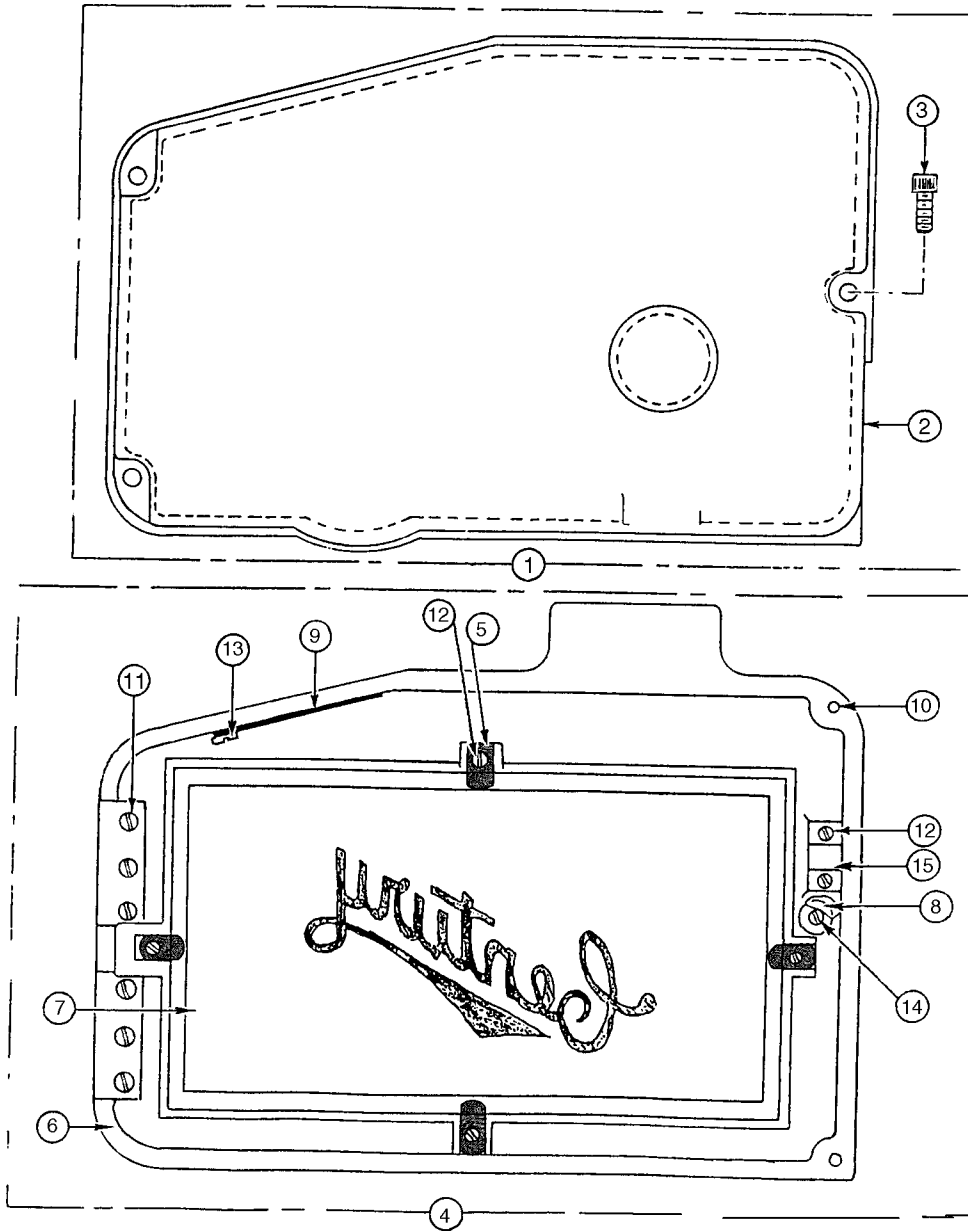

R31-E GEAR COVER & ACCESS DOOR

<u>Item</u>	<u>Part No.</u>	<u>Description</u>
1	R31-11	Gear Compartment Cover
2	CR-0612	Cover Casting
3	SC-0137	Cover Mounting Screw (3 req'd.)
4	R31-20	Film Compartment Access Door
5	CP-0020	Window Glass Clamp (4 req'd.)
6	DO-0075	Door Casting
7	GL-0205	Door Glass
8	KN-0047	Knob
9	LI-0007	Door Stop Link
10	SB-0060	Felt Door Cushion
11	SC-0070	Hinge Mounting Screw (6 req'd.)
12	SC-0123	Fastening Screw (6 req'd.)
13	SC-0226	Stop Link Screw
14	SC-1356	Knob Mounting Screw
15	SS-0528	Order C1-A-76

