

# FILM-TECH

**THE INFORMATION CONTAINED IN THIS ADOBE ACROBAT PDF FILE IS PROVIDED AT YOUR OWN RISK AND GOOD JUDGMENT.**

**THESE MANUALS ARE DESIGNED TO FACILITATE THE EXCHANGE OF INFORMATION RELATED TO CINEMA PROJECTION AND FILM HANDLING, WITH NO WARRANTIES NOR OBLIGATIONS FROM THE AUTHORS, FOR QUALIFIED FIELD SERVICE ENGINEERS.**

**IF YOU ARE NOT A QUALIFIED TECHNICIAN, PLEASE MAKE NO ADJUSTMENTS TO ANYTHING YOU MAY READ ABOUT IN THESE ADOBE MANUAL DOWNLOADS.**

**[WWW.FILM-TECH.COM](http://WWW.FILM-TECH.COM)**



# Digital Theater Systems

Installation and Operation Manual

DTS-CSS Cinema Subtitling System



April 12, 2002

DTS Part #9301E450001.2

**DTS Europe**

Digital Theater Systems (UK) Ltd  
5 Tavistock Estate  
Ruscombe Lane  
Twyford, Berkshire RG10 9NJ, UK  
Phone: +44 (0) 1189.349.199  
Fax: +44 (0) 1189.349.198  
E-mail: [dtsinfo@dtsonline.co.uk](mailto:dtsinfo@dtsonline.co.uk)

**Digital Theater Systems, Inc.**

5171 Clareton Drive  
Agoura Hills, CA 91301  
Phone: 1.800.959.4109 or 1.818.706.3525  
Fax: 1.818.706.1868  
E-mail: [dtsinfo@dtsonline.com](mailto:dtsinfo@dtsonline.com)  
[www.dtsonline.com](http://www.dtsonline.com)

**DTS Japan**

AT Communications KK (Liaison Office)  
2-14-4 Shinonome, Koto-ku  
135-0062 Tokyo, Japan  
Phone: +81 (0) 3.5564.7156  
Fax: +81 (0) 3.3520.1022  
E-mail: [asano@dtstech.co.jp](mailto:asano@dtstech.co.jp)  
[www.dtstech.co.jp](http://www.dtstech.co.jp)

## TABLE OF CONTENTS

<u>SECTION</u>	<u>PAGE</u>
I. DTS-CSS SYSTEM OVERVIEW	
1.1. Features and Options .....	1-1
1.2. How It Works .....	1-2
1.3. Terminology .....	1-2
1.4. Specifications .....	1-3
1.5. Regulatory Notices .....	1-4
II. THE DTS-CSS UNIT	
2.1. DTS-CSS Front Panel .....	2-1
2.2. DTS-CSS Back Panel .....	2-2
2.3. Inside The DTS-CSS .....	2-3
III. SYSTEM OPTIONS	
3.1. DTS Digital Sound Playback Units .....	3-1
3.2. DTS Timecode Readers .....	3-1
3.3. DTS Shaft Encoder .....	3-1
3.4. DTS-CSP Subtitle Projector Option .....	3-1
3.5. Narration Option .....	3-1
3.6. Captions Option .....	3-1
Drawings: DTS-CSP, DTS-EMA, Mounting Assembly .....	3-2
IV. SYSTEM INSTALLATION	
4.1. DTS-CSS Rear Panel Connectors, Pin-out Table .....	4-1
4.2. DTS-CSS Installation .....	4-3
4.3. DTS Timecode Reader Installation (DTS 35mm) .....	4-3
4.3.1. DTS 70mm Timecode Reader Installation .....	4-3
Drawing: Timecode reader head auxiliary roller installation (and positioning) .....	4-4
Drawing: Standard mounting for DTS timecode readers .....	4-5
4.3.2. DTS 35mm and 70mm Readers Used On The Same Bracket .....	4-6
Drawing: Special mounting/adapters when switching between DTS 35mm & 70mm readers .....	4-7
4.4. Timecode Reader Brackets, 35mm and 70mm .....	4-8
Drawings: Standard mounting brackets .....	4-9
Drawings: Special mounts/adapters, used for switching between DTS 35mm & 70mm readers ..	4-12
Drawing: Installing reader with spacer plates on a Mag. Head (projector) .....	4-15
4.5. DTS-CSP, Subtitle Projector .....	4-16
4.5.1. Installing the DTS-CSP in a projection booth .....	4-16
4.5.2. Mounting Procedure .....	4-17
Illustrations: Steps for installing the DTS-CSP in a projection booth .....	4-18
4.6. Installing Narration Transmitter and Caption Equipment .....	4-17
4.7. DTS-CSS System Wiring Diagrams .....	4-21

## TABLE OF CONTENTS

<u>SECTION</u>	<u>PAGE</u>
V. SYSTEM SETUP AND TEST	
5.1. System Setup Check List .....	5-1
5.2. DTS-CSS Unit Setup .....	5-1
BOOT-UP .....	5-1
Setting OFFSET (sync) .....	5-2
Determining DTS Reader OFFSET Value .....	5-3
Drawing: DTS Reader Installation .....	5-4
5.3. Narration Option Setup .....	5-5
5.4. Caption Option Setup .....	5-5
5.5. Subtitle Projector Option Setup .....	5-6
5.5.1. DTS-CSP Subtitle Projector Setup .....	5-6
5.5.2. Positioning the DTS-EMA Mask Trims .....	5-9
5.5.3. Positioning and Refining Subtitle Image On-Screen .....	5-10
5.5.4. Final Programming .....	5-11
Enable User Selectable Languages, Setting Password .....	5-11
Playback Setup: Selecting Playback Language, Setting Projector Power .....	5-11
5.6. Loading DTS-CSS Show Programs .....	5-12
5.7. DTS-CSS Menus .....	5-12
5.8. DTS-CSS System Test .....	5-15
VI. USER SYSTEM OPERATION	
6.1. How Do I Prepare For A Show? .....	6-1
6.2. How Do I Power On/Off The DTS-CSS? .....	6-1
6.3. How Do I Install Show Programs Into The DTS.CSS? .....	6-1
6.4. How Do I Select Show Programs On The DTS-CSS? .....	6-2
6.5. How Do I Know When The DTS-CSS System Is Operating Correctly? .....	6-2
6.6. What Regular Maintenance Is Required On The DTS-CSS System? .....	6-2
6.7. How Do I Replace The Lamp On The DTS-CSP, Subtitle Projector? .....	6-2
VII. MAINTAINANCE AND TROUBLESHOOTING	
7.1. Upgrading DTS-CSS System Software .....	7-1
7.2. Loading DTS-CSS Show Program .....	7-1
7.3. DTS-CSS System Maintenance .....	7-1
7.4. DTS-CSP, Subtitle Projector Maintenance .....	7-1
7.4.1. Adequate Air Space .....	7-1
7.4.2. Maintaining The Lens .....	7-1
7.4.3. Procedure For Cleaning The Lens .....	7-2
7.4.4. Procedure For Replacing The Lamp Module .....	7-2
7.5. Troubleshooting The DTS-CSS System .....	7-6
Drawing: DTS-EMA Assembly .....	7-8
Drawing: DTS Timecode Track Placement On 35mm Film .....	7-9
Drawing: DTS Timecode Track Placement On 70mm Film .....	7-10
7.6. DTS Technical Support .....	7-11
7.6.1. DTS System Test Materials .....	7-11
7.7. DTS-CSS System Replacement Parts List .....	7-11
7.8. DTS-CSS System Parts List .....	7-12

VIII. APPENDICES

[Appendix A: Cleaning the DTS-CSP Lamp Filter Screen](#)

# **NOTES**

*Thank you for choosing DTS !*

## SECTION 1                      DTS-CSS SYSTEM OVERVIEW

The DTS-CSS is a stand-alone or an accessory part of the standard DTS digital sound playback system for cinemas. The DTS-CSS has the ability to **project subtitles** and interface to systems that provide **access programs** for visually impaired, deaf and hard of hearing audiences.

With the DTS-CSS, film distributors can use domestic prints in foreign language markets without having to create separate prints with foreign language soundtracks or new prints with **subtitles** for a given territory. Subtitles no longer have to be etched or over-laid onto the film itself. Using the DTS-CSS, subtitles are projected directly onto the screen allowing theaters to easily adapt shows for each audience. For instance, an English language print with French subtitles can play in the morning and then that afternoon, Spanish subtitles can be played for different audience - all accomplished with a simple change of program on the DTS-CSS menu

For years, DTS has provided foreign language discs (for DTS Digital 6-track playback) to play with original version prints. The DTS-CSS provides the added benefit of delivering subtitles, captions, and a descriptive narrative track for the same print. The same **DTS timecode** used to sync digital sound on DTS 6-track feature discs (in a DTS digital player) is used to sync the subtitling/captioning/narration information in the DTS-CSS to the feature playing. This allows 6-track DTS digital sound soundtracks to play independently and at the same time the DTS-CSS delivers subtitles, captions, and/or narration to the picture projected.

### 1.1.    FEATURES AND OPTIONS

The DTS-CSS **features**:

- Utilizes standard DTS timecode reader head to synchronize subtitles, captions, and descriptive narration.
- Automatically monitors the subtitle projector's lamp hours. After 1400 hours of use, the DTS-CSS "LAMP" light will illuminate alerting you that it is time to change the lamp. If, by chance, the subtitle projector's lamp extinguishes, the DTS-CSS "LAMP" light will blink.
- Automatically controls the subtitle projector's douser.
- Automatically plays the narration track and subtitle track as selected from the CSS menu.
- Has a self-switching universal AC input.
- Contains a DVD drive for loading programs and a hard-drive to store programs.
  - ☑ Up to 40 different languages can be stored on one "subtitle" disc.
  - ☑ Front panel display and buttons allow easy access to subtitle, narration, and caption programs.

The following **options** are available for the DTS-CSS System:

- DTS-CSP subtitle projector with DTS-EMA mount. Various lenses are available to suit most installations
- Narration transmitter (with /receiver-headsets)
- Interface to caption systems (such as Rear Window™, WGBH Boston)

The DTS-CSS supports and easily **interfaces** the following systems:

- DTS digital sound playback system (DTS-6, DTS-6D, DTS-6AD)
- Rear Window™ Captioning System (WGBH Boston)
- DVS Theatrical® System

## 1.2. HOW IT WORKS

Depending on the wishes of the distribution company for a given film, three types of discs can be provided to a theater equipped with the DTS-CSS:

- **Narration** information is delivered on a “Show Narration” disc.
- **Captioning** information is delivered on a “Show Caption” disc.
- **Subtitling** information is delivered on a “Show Subtitle” disc.

All show discs are labeled with the film’s title, language, and specific serial number that must match the serial number embedded in DTS timecode printed on film. DTS-CSS discs are loaded one at a time into the DTS-CSS unit and the information is automatically downloaded from the DVD drive to the hard drive. Unlike the DTS-6/-6D/-6AD, the DTS-CSS discs are used to download programs to the hard drive only and all programs are played off the hard drive. Using the display scroll feature on the DTS-CSS, the operator can easily verify the loaded programs and select the program (such as subtitle language) needed for each show.

The projectionist threads the film through a DTS timecode reader head and projector. Once the film is started, the DTS-CSS uses the DTS timecode to play its programs in sync with the picture projected. The DTS player delivers the 6-track digital soundtrack and the DTS-CSS system:

- Delivers a **descriptive narration** track to a transmitter that is heard by patrons wearing receivers.
- Delivers **subtitle text** to a separate projector that projects text directly onto the screen.
- Sends **serial commands** to control the subtitle projector or the “Rear Window™ Captioning System”.

## 1.3. TERMINOLOGY

- **CAPTIONS** Projected text of, mainly, on-screen dialogue to aid hearing impaired audiences. Captions differ from subtitles in that they are more descriptive of the scene, not just dialogue. For instance, a musical note may be displayed if music is being played on-screen.
- **DESCRIPTIVE NARRATION** <sup>①</sup> A mono audio track describing on-screen action is transmitted to those patrons wearing special headsets (receivers). The goal is to include the visually impaired community in the movie-going experience.
- **SUBTITLES** Projected text of on-screen dialogue that has been translated into a language different than the original version. The goal is to play the original version print for audiences that speak a different language
- **REAR WINDOW™ CAPTIONING** <sup>②</sup> Printed text of on-screen dialogue that is read by patrons having individual panels in front of them. The goal is to include the hearing impaired community in the movie-going experience. In this case, the captions are not projected onto the movie screen.

## NOTES

- ① The DVS Theatrical® System sends a mono descriptive audio (narration) track to a transmitter that is heard by patrons wearing single-ear headsets.
  - ② The Rear Window™ Captioning System. Generally used for captioning. LED data wall is placed on the rear wall of the auditorium. The DTS-CSS delivers captions that scroll across the data wall. Patrons use individual reflector panels to view the wall data. This system is transparent to other patrons not utilizing the system.
3. DTS Digital 6-track sound playback is accomplished using a separate DTS player and feature discs.



## 1.4. SPECIFICATIONS

### DTS-CSS

Physical Dimensions	Height: 5.25" = three rack spaces (13.34 cm) Width: 19" rack mount (48.26 cm) Depth: 15.25" (38.74 cm)
Weight (unit only)	17.5 Lbs. (7.94 Kg)
Narration Output Level	117 mV RMS, nominal
Power Requirements	Universal supply, self-switching input 85 to 264 VAC, at 47 to 64 Hz
Power Consumption	150 watts

### DTS-CSP, SUBTITLE PROJECTOR

Physical Dimensions	Height: 3.9" (9.9 cm) Width: 9" (22.86 cm) Depth: 12" (30.48 cm)
Weight (projector only)	6.0 Lbs. (2.72 Kg)
Operating Case Touch Temperature	194° F (90° C)
Power Requirements	100 to 240 VAC, at 50 to 60 Hz
Power Consumption	400 watts
Available Projectors	<b>DTS-CSP</b> (for throws up to 50 feet, standard) <b>DTS-CSPL1</b> (for throws up to 120 feet)
Lamp Replacement	Every 1400 hours

### MOUNTING (for DTS-CSP)

#### DTS-EMA (mask/mount adapter)

Mask/mount Adapter Dimensions (connects DTS-CSP to mount)	Height: 8" (20.32 cm) Width: 7" (17.78 cm) Length: 19" (48.26 cm)
Mask/mount Adapter Weight (without DTS-CSP)	5.7 Lbs. (2.6 Kg.)

#### DTS P/N 1010 0037 00 (mount)

<u>Mount Dimensions</u> <i>Mount is rated for objects weighing up to 55 pounds (25 Kg)</i>	
Mounting Plate (connects to ceiling/wall)	3.5" (8.89 cm) x 6" (14.24 cm)
Mount Shaft	14" long (35.56 cm)
Mount Clearance (from wall)	6" (14.24 cm)
Mount Weight (mounting bar, plate, clamp)	3.5 Lbs. (1.6 Kg)
*Plate Fasteners Requirement	Four at 3/8" (9.5 mm) in diameter
*NOTE: Plate fasteners not supplied by DTS	

## 1.5. REGULATORY NOTICES

### EMI NOTICE

This equipment has been tested and found to comply with the limits for a Class A digital device, pursuant to Part 15 of the FCC Rules. These limits are designed to provide reasonable protection against harmful interference when the equipment is operated in a commercial environment. This equipment generates, uses, and can radiate radio frequency energy and, if not installed and used in accordance with the instruction manual, may cause harmful interference to radio communications. Operation of this equipment in a residential area is likely to cause harmful interference in which case the user will be required to correct the interference at his own expense.

*Canadian Department of Communications compliance statement:*

This equipment does not exceed Class A limits per radio noise emissions for digital apparatus set out in the Radio Interference Regulation of the Canadian Department of Communications. Operation in a residential area may cause unacceptable interference to radio and TV reception requiring the owner or operator to take whatever steps are necessary to correct the interference.

*Avis de conformite aux normes du ministere des Communications du Canada:*

Cet equipment ne depasse pas les limites de Classe A D'emission de bruits radioelectriques pour les appareils numeriques telles que perscrites par le Reglement sur le brouillage radioelectrique etabli par le ministere des Communications du Canada. L'exploitation faite en milieu residentiel peut entrainer le brouillage des receptions radio et television, ce qui obligerait le proprietaire ou l'operateur a prendre les dispositions necessaires pour en eliminer les causes.

### CE

**\*Warning\*** This is a Class A product. In a domestic environment this product may cause radio interference in which case the user may be required to take adequate measures.

### PATENTS

The DTS system has been granted the following patents:

United States of America Patent Nos. 5155510, 5386255, 5450146, 5751398, 5956674, 5974380, 6226616

Europe Patent Nos. 473677, 551424, 614631, 666495

*Other U.S.A. and Foreign patents issued and pending.*

## SECTION 2 THE DTS-CSS UNIT

### 2.1. DTS-CSS FRONT PANEL

- DVD Drive Loads information on disc to the hard drive.
- Status LEDs
  - TITLES Illuminates green when subtitles (or captions) are playing.
  - AUDIO Illuminates green when the narration track is playing.
  - AUX Illuminates green when Rear Window™ system is playing.
  - TIMECODE Illuminates green when good timecode is seen.
  - SYSTEM Blinks green when system is fully booted and ready to play.
  - LAMP Illuminates red when subtitle projector lamp needs replacement, blinks red when lamp burnt out.
- Display Four line display, shows status of unit and menu/programs.
- Selector Buttons
  - ENTER button selects menu item to program.
  - Navigation buttons allow you to select a menu item ◀ ▶, and to scroll through choices and make adjustments ▲ ▼
- Power Switch “1” = On, “0” = Off

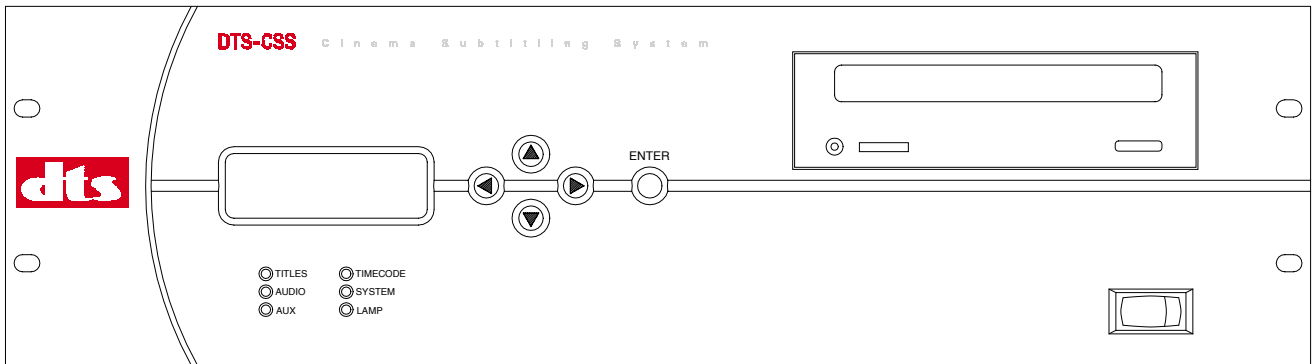

## 2.2. DTS-CSS BACK PANEL

TIMECODE	Connects to DTS timecode reader and, when used, looped to DTS player “Timecode” connector.
AUDIO OUT CH 1 / CH 2	Two channels are available. Mono audio out, factory set at 117 mV RMS nominal, narration track to transmitter. Normally, only “CH 1” is used.
DOUSER / FAN CONTROL	Serial commands to DTS-EMA (subtitle projector external mask)
AUTOMATION	(future)
COM 1	Functional communication to the subtitle projector and/or caption system
PROJECTOR VIDEO	Video image data to the subtitle projector
Power Supply	Provides power to DTS-CSS system. An universal supply capable of accepting AC in from 85VAC to 264VAC between 47Hz and 64Hz. Always set switch to “1” = on. Contains built-in cooling fan.

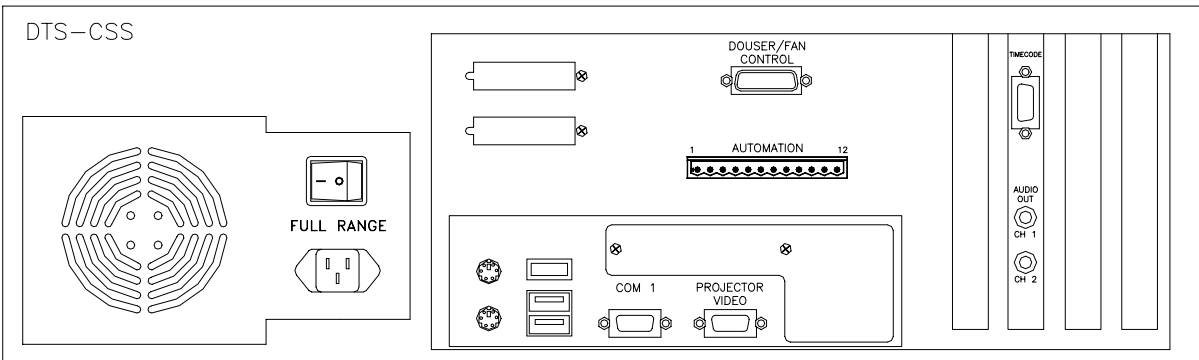

### 2.3. INSIDE THE DTS-CSS UNIT

E303 BOARD	Audio and Timecode Board
E430 EMA INTERFACE BOARD	Controls DTS-EMA douser and powers the EMA fan
MOTHERBOARD	Computer board
E221	Display and switch assembly
POWER SUPPLY	Supplies regulated power to DTS-CSS unit
DVD DRIVE	Allows downloading of software and show programs delivered on disc
HARD DRIVE	Holds all software for DTS-CSS operation and show programs
IDE Cable	Connects motherboard to drives

### DTS-CSS TOP VIEW

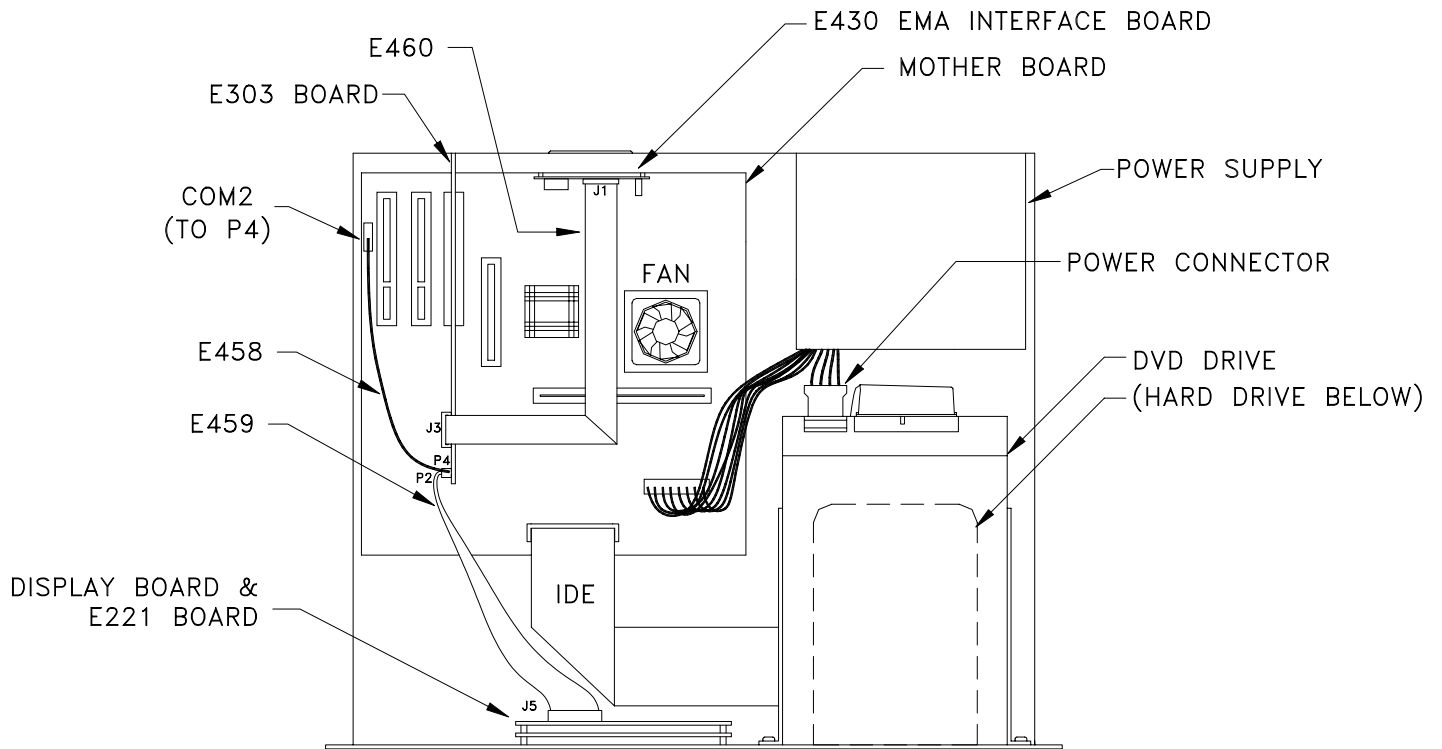

# NOTES

*Thank you for choosing DTS !*

## SECTION 3 SYSTEM OPTIONS

### 3.1. DTS DIGITAL SOUND PLAYBACK UNITS

The following DTS digital sound playback units can be used with the DTS-CSS: DTS-6, DTS-6D, and DTS-6AD. These units are used to play back the **5.1 digital sound** track (on DTS disc) for the film projected. Further information on these products can be found in their respective manuals.

### 3.2. DTS TIMECODE READERS

Standard DTS timecode reader reads DTS timecode printed on film. Two models are available, the DTS Model D600-00 is for **35mm film** and the D600-02 is for **70mm film**.

### 3.3. DTS SHAFT ENCODER OPTION

The DTS shaft encoder is used to sync DTS playback to a print not having DTS timecode. In this application, a DTS interface box is required in the system design. A DTS timecode reader is not used.

### 3.4. DTS-CSP SUBTITLE PROJECTOR OPTION

The DTS Model DTS-CSP subtitle projector is designed to be mounted in the projection booth or in the auditorium. For most theaters, it will be in the projection booth. It is used to project subtitles that are supplied by the DTS-CSS software. The subtitle text (software) is downloaded into the DTS-CSS on a "show disc." Once downloaded, the projectionist scrolls through the DTS-CSS menu and chooses the language desired for each show. Once the language is selected and film is started, the correct subtitles are projected in sync with action on-screen.

Along with the DTS-CSP, there is a special **external mask assembly** DTS-EMA and optional **mounting assembly** DTS P/N 1010 0037 00.

- The DTS-EMA consists of a bracket, douser, cooling fan, and adjustable magnetic trims.
- The mounting assembly consists of a foot, shaft, and clamp. The foot attaches directly to a wall or ceiling, and the clamp attaches directly to the DTS-EMA.

### 3.5. NARRATION OPTION

As in the DVS Theatrical® System, a transmitter is usually placed in the projection booth. It is used to transmit a mono narration track that describes on-screen action. The narration audio is delivered to the transmitter by the DTS-CSS. The audio file is downloaded into the DTS-CSS on a "show disc." Once downloaded and film is played, the narration is transmitted in sync with action on-screen. Special single-ear headsets receive the transmitted signal. This allows patrons wearing headsets to hear the narration track in one ear and still hear the sound track played in the auditorium with the other, uncovered ear.

### 3.6. CAPTIONS OPTION

A caption system, such as the Rear Window™ Captioning System, usually consists of a separate rear display (placed at the rear of the theater) and individual Plexiglas viewers. The caption file is downloaded into the DTS-CSS on a "show disc." Once downloaded and film is played, the rear display prints out dialogue in "mirror image" in sync with action on-screen. Plexiglas viewers are positioned in front of individual patrons and reflect the mirror image. Once reflected, the text is seen "right side up" allowing it to be read by individual viewers.

*The DTS-CSP, subtitle projector*

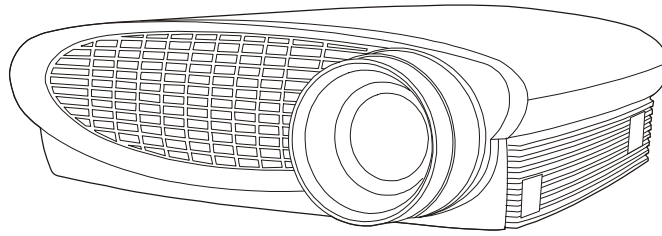

*The external mask assembly DTS-EMA (for the DTS-CSP, subtitle projector)*

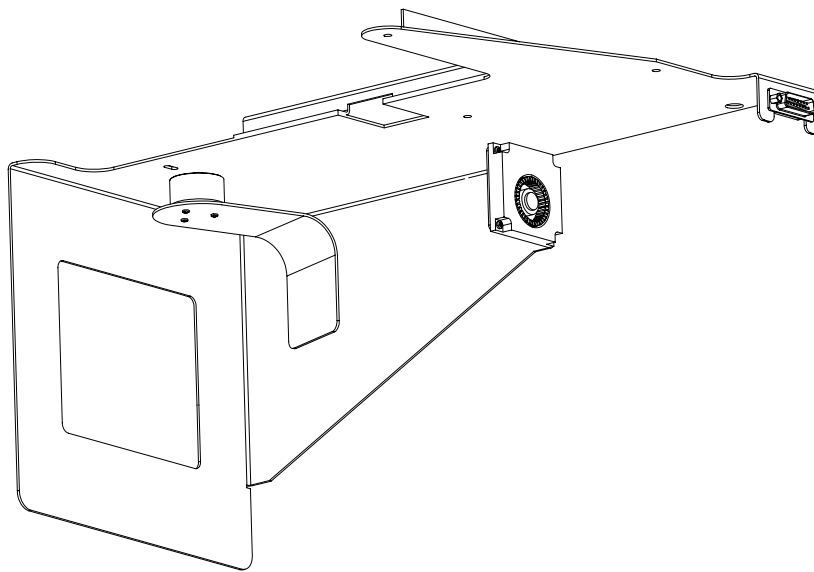

*The mounting assembly, P/N 1010 0037 00 (for the DTS-EMA external mask)*

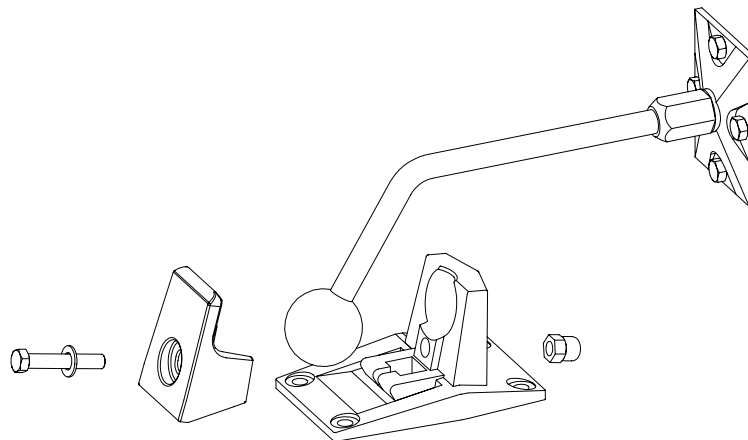



## SECTION 4                      INSTALLATION

### 4.1.    DTS-CSS REAR PANEL CONNECTOR PIN-OUTS

#### TIMECODE

Pin 1	Timecode signal in from PROJ1	The “Timecode” cable connects DTS-CSS to the timecode source, usually DTS reader(s).
Pin 2	Timecode signal in from PROJ2	
Pin 3	Not used	The “Timecode” cable should loop back to DTS player (DTS-6/-6D/-6AD), if used.
Pin 4	Not used	
Pin 5	+5VDC supply to reader(s)	
Pin 6	Ground	
Pin 7	Ground	
Pin 8	Ground	
Pin 9	LED drive signal to reader(s)	

9-pin, female D-connector on DTS-CSS rear panel

#### AUDIO OUT, CH 1 / CH 2    (*mono audio, narration out, to a transmitter*)

Tip	Audio Signal	The “Audio Out” cables connect DTS-CSS to the transmitter audio input.
Sleeve	Audio Ground	

RCA, female connector on DTS-CSS rear panel

#### COM 1    (*functional communication to the subtitle projector / caption equipment*)

Pin 1	Not used	This null modem cable connects DTS-CSS to the DTS-CSP subtitle projector control or caption equipment
Pin 2	Receive Data	
Pin 3	Transmit Data	
Pin 4	Not used	
Pin 5	Signal Ground	
Pins 6 – 9	Not used	

9-pin, male connector on DTS-CSS rear panel

#### PROJECTOR VIDEO    (*video image data to the DTS-CSP subtitle projector*)

Pin 1	Video	The “Projector Video” cable connects DTS-CSS to the DTS-CSP subtitle projector video input.
Pin 2	Video	
Pin 3	Video	<b>Video interconnect cable must be manufactured by DTS</b>
Pin 4	Reserved	
Pin 5	Ground	
Pin 6	Video Ground	
Pin 7	Video Ground	
Pin 8	Video Ground	
Pin 9	+5 VDC	
Pin 10	Sync Ground	
Pin 11	Monitor	
Pin 12	Data Line	
Pin 13	Horizontal Sync	
Pin 14	Vertical Sync	
Pin 15	Clock	

15-pin, female high density D-connector on DTS-CSS rear panel

**DOUSER / FAN CONTROL**      *(control data to the DTS-EMA, external mask)*

Pin 1	Douser OP Sense
Pin 2	Douser CL Sense
Pin 3	Fan Sense
Pin 4	N.C..
Pin 5	N.C.
Pin 6	N.C.
Pin 7	N.C.
Pin 8	Douser Control
Pin 9	+12 VDC
Pin 10	+12 VDC
Pin 11	+12 VDC
Pin 12	+12 VDC
Pin 13	DC Ground
Pin 14	DC Ground
Pin 15	DC Ground

The “Control” cable connects the DTS-CSP subtitle projector to the DTS-EMA external mask.

---

15-pin, female D-connector on DTS-CSS rear panel

**AUTOMATION**      *(future, to be determined)*

Pin 1
Pin 2
Pin 3
Pin 4
Pin 5
Pin 6
Pin 7
Pin 8
Pin 9
Pin 10
Pin 11
Pin 12

---

12-pin terminal block with screw terminals that connects to the male connector on the DTS-CSS rear panel

## 4.2. DTS-CSS INSTALLATION

**Tools Required:** #2 Phillips screwdriver and 1/8" flat blade screwdriver

1. Mount the DTS-CSS into the sound rack.
2. If used, mount the DTS-CSP subtitle projector (Section 4.5) and narration transmitter (Section 4.6).
3. If a DTS system is not installed, mount the DTS timecode reader head or DTS shaft encoder onto the projector. If shaft encoder used, install the special DTS encoder interface box.
4. If a new DTS digital playback system is being installed, see player manual for instructions.
5. Connect cables as shown in DTS-CSS system wiring diagrams (Section 4).
6. Proceed to Setup (Section 5).

## 4.3. DTS TIMECODE READER INSTALLATION (standard for all readers)

**Tools Required:** Crescent wrench, 1/8" flat blade and #2 Phillips screwdrivers, selection of hex keys (including 7/64"), and film strip about 5 feet long.

The DTS Timecode Reader is designed to mount onto most projectors with a single mounting bracket and **MUST** be placed above the picture gate.

1. Position appropriate DTS mounting bracket on the same bolt pattern as the reel arm. Bolt securely in place.
2. Install the reader onto the mounting bracket and bolt into place with supplied hardware.
3. Reinstall reel arm on the top bolt pattern of the mounting bracket.
4. Using film strip, align the film path from the reel arm to the DTS reader (mounted on a bracket that is connected to the projector).
5. The timecode reader **MUST** be aligned so that the film has a straight path (no angles or twists) and at least a small amount of **tension**. The auxiliary flanged roller on the reader is used to avoid film "walk out" and helps to stabilize the film by adding tension. The tension can be adjusted by changing the swing of the auxiliary roller toward the large center roller. Adjust the position of the auxiliary roller so that it has as much film wrap as possible.
6. **Two projector (change-over) theaters**  
Be sure to place each reader at the same place on each projector. **The delay (offset) value must be the same for the movie to play in sync at both projectors.**
7. Connect the 9-pin timecode cable(s) to the reader(s) and to the DTS-CSS, and DTS player, if used.

### 4.3.1. DTS 70MM TIMECODE READER INSTALLATION

The DTS 35mm and DTS 70mm reader heads may be used at the same projector in one of two ways. ① Mount each independently of the other or ② have both use one bracket. In the first case case, each reader would be permanently mounted to the projector using two brackets - one bracket per reader. However, most will find it easier to use one bracket with breakaway plates so the readers can be switched as needed.

In either case, be sure to calculate and mark the delay (offset) for each. **The delay for 35mm will be different from 70mm.**

## Installation Procedure, Timecode Reader Head Auxiliary Roller

The Auxiliary Roller is designed to mount on either of the two Secondary rollers of the Timecode Reader Head, as detailed below:

1. Remove the screw ① from the end cap ② of the desired secondary roller ③, and remove the end cap ②.
2. Loosen the set screw ④ which holds the roller shaft ⑤ of the secondary roller ③.
3. Gently push the roller shaft ⑤ out of the secondary roller ③. Note: Excessive force may damage the bearings ⑥. Be careful not to lose the washer ⑦, or the bearings ⑥ that mount on the roller shaft ⑤.
4. Install the longer roller shaft ⑧ provided. Note: The flat section on the roller shaft ⑧ should face the set screw ④ in the Reader Head. About 1/4" of the longer roller shaft ⑧ will protrude from the bottom of the Reader Head.
5. Tighten the set screw ④, and replace the secondary roller ③ and end cap ②.
6. Make sure that the secondary roller ③ spins freely. If not, loosen the set screw ④ and adjust the roller shaft ⑤ up slightly. This should free the secondary roller ③. If, after adjustment the secondary roller ③ still does not spin, double check that all parts have been properly replaced onto the roller shaft ⑤.
7. Place the Auxiliary Roller ⑨ on the protruding section of the roller shaft ⑧, in the desired position ⑩, and tighten the cap screw ⑪.

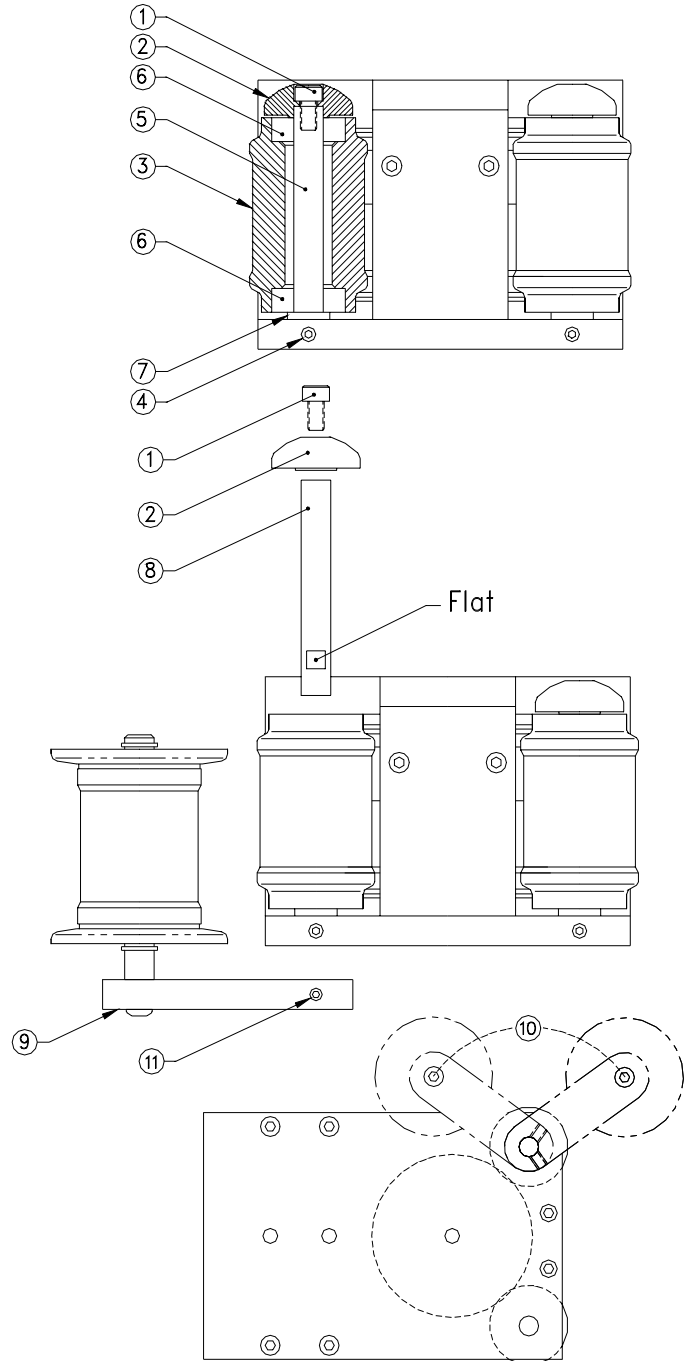

**Standard mounting for DTS timecode readers**

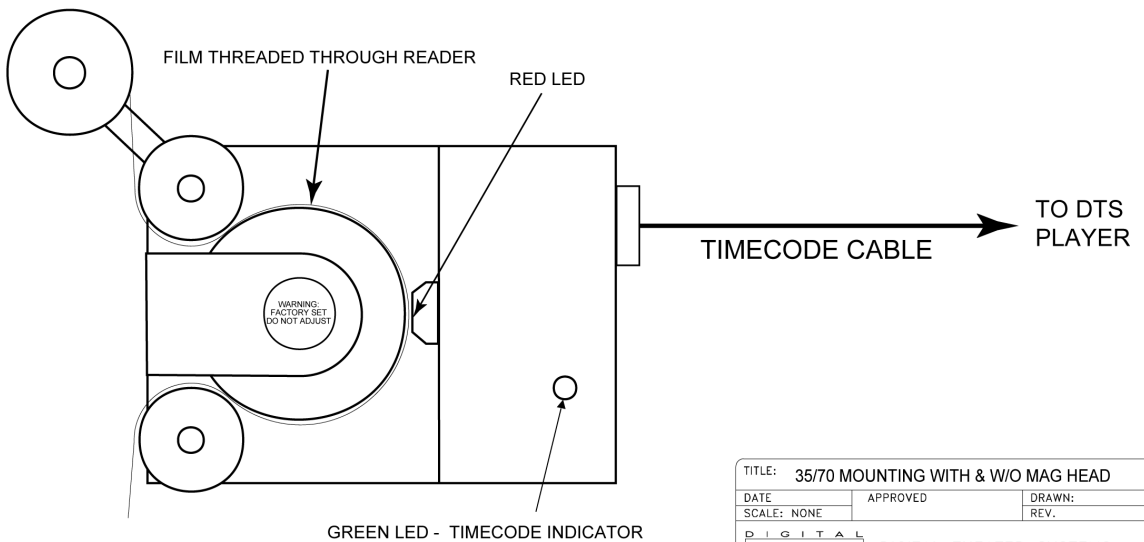
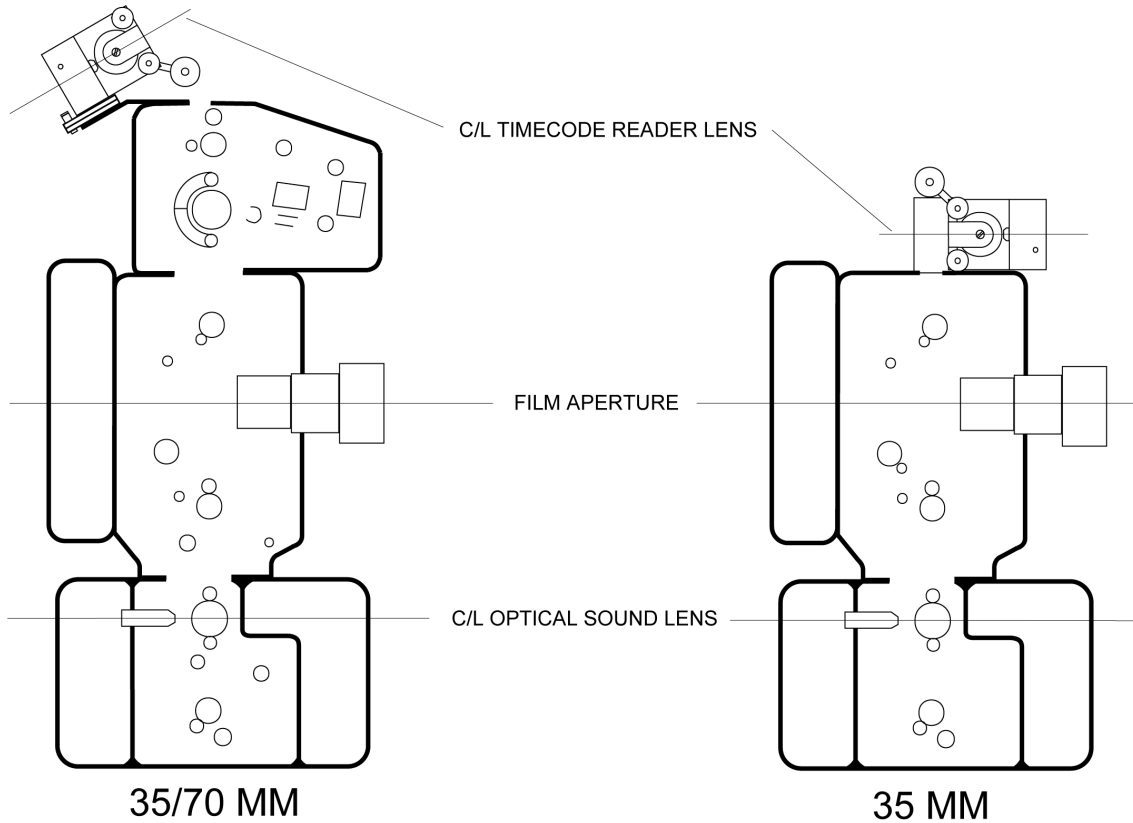

TITLE: 35/70 MOUNTING WITH & W/O MAG HEAD		
DATE	APPROVED	DRAWN:
SCALE: NONE		REV.
 DIGITAL THEATER SYSTEMS 5171 CLARETON DR. AGOURA HILLS, CA 91301		
FILE NAME	DWG.NO.	
TIE245A (3570MAG).AI	TI-E245	

### 4.3.2. DTS 35MM & 70MM READER USED ON THE SAME BRACKET

If both 35mm and 70mm reader heads are to be used on the same bracket, add **spacer breakaway plates** to the readers. They are added to allow quick changes between the two. Keep the plates attached to the readers and maintain them as a set once the projector alignments are finished. See below.

- Start by mounting the 70mm reader (with its breakaway plate attached) to the bracket. Use 70mm film to align reader. Once aligned, tighten bracket screws. Loosen the thumbscrew on the breakaway plate so that the 70mm reader detaches from the bracket.
- Now attach the 35mm reader (with its breakaway plate attached) to the bracket. Use 35mm film to verify the alignment path is correct -- no corrections should be necessary. The principle is to have one alignment for both readers so that no projector adjustments are needed when the readers are exchanged.

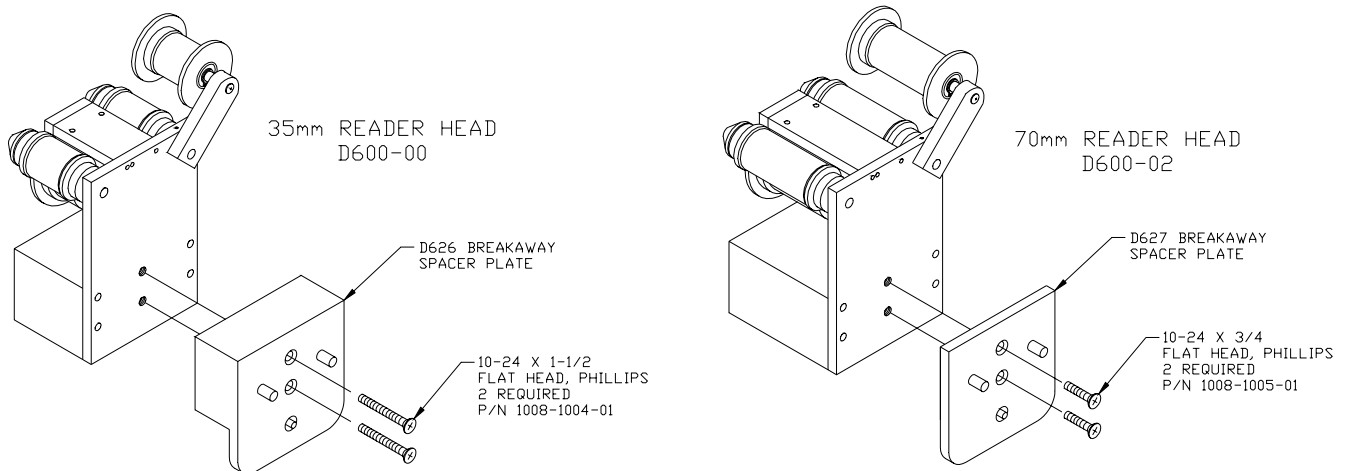

**Special mounting/adapters when between DTS 35mm & 70mm Readers**

**DTS - 70mm Timecode Reader and Mounting Brackets**

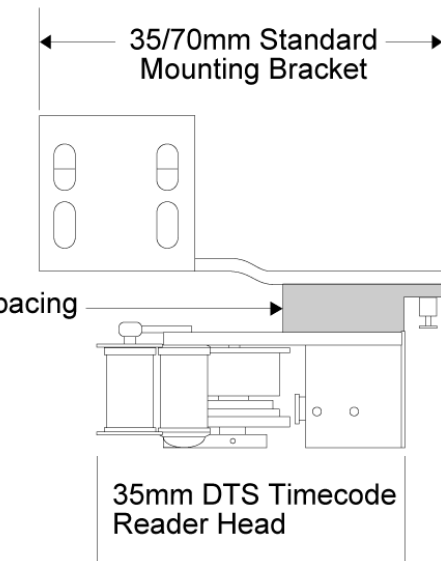
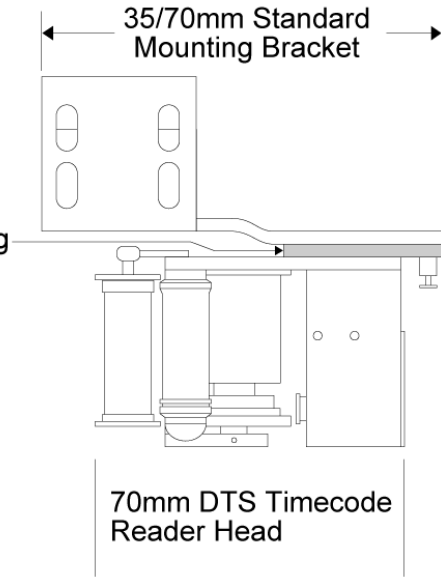
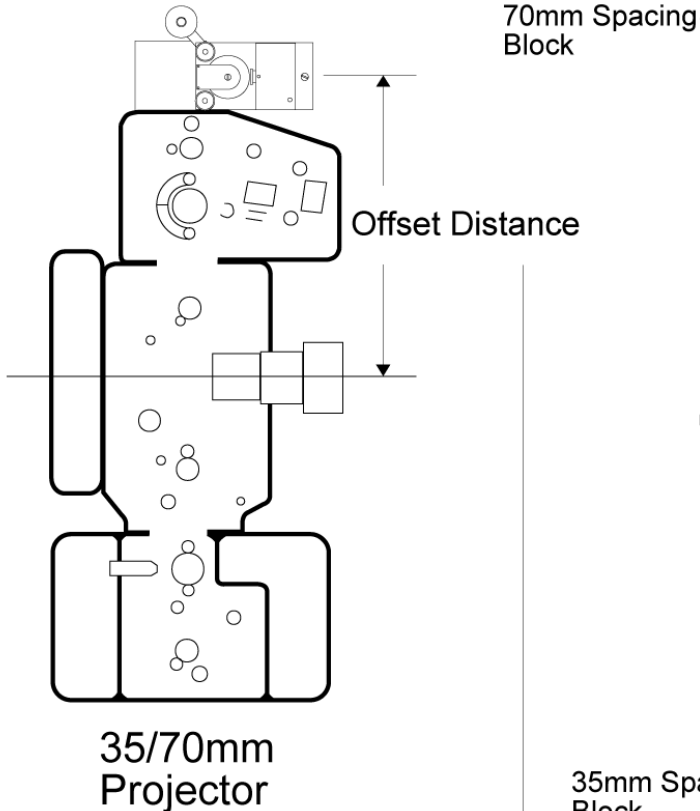

In order to properly set the offset for 70mm film on the DTS unit, count the number of frames between the picture aperture and the timecode reader head. Multiply by 1.25 and subtract one.

For example,

Distance between (70mm) Picture Aperture & Timecode Reader Head	24 Frame/Sec Offset Setting
(24 frames X 1.25) - 1	=29
(12 frames X 1.25) - 1	=14

TITLE: 70MM TCRH MOUNTING & BRACKETS		
DATE	APPROVED	DRAWN: J. DELLARIA
SCALE: NONE		REV. A
 DIGITAL THEATER SYSTEMS 5171 CLARETON DR. AGOURA HILLS, CA 91301		
FILE NAME	TIE241A (70MM-MNT).AI	DWG.NO. TI-E241A

PH: 818-706-3525 Fax: 818-706-1868  
 Web: www.dtsonline.com

**4.4. TIMECODE READER BRACKETS, 35MM AND 70MM**

- **D614 - Standard Bracket (35mm only)** -- cannot be used with breakaway plates.

- **D625 - 35mm / 70mm Standard Bracket** -- used with breakaway plates.

For projectors: Century, Simplex, and Cinemeccanica with Kelmar bracket (see below). Intended to fit between the projector and reel arm. We have produced the bracket with the American standard size hole to accommodate 2" center spacing 3/8 - 16 tap, that is utilized to mount the American made upper reel arms. Comes with the following hardware:

<u>Application</u>	<u>QTY</u>	<u>Description</u>
35mm	2	10 x 24 x 1/2" long screws
35mm	2	3/4 x 16 x 1" long hex bolt nuts
35mm / 70mm	2	3/8 lock washers
70mm	2	3/8 x 1 1/2" long cap screws
70mm	2	3/8 flat washers
70mm	2	3/8 hex nuts

- **D615 - DP70 Universal Bracket (35mm only)**

Used for American projectors with a penthouse. Comes with tap and drill bit 8-32, and the following hardware:

<u>QTY</u>	<u>Description</u>
2	10 x 24 x 1/2" long screws
2	3/4 x 16 x 1" long hex bolt nuts
2	3/8 lock washers

- **D616 - AA2 bracket (35mm only)**

For Norelco AA projectors. Comes with the following hardware:

<u>QTY</u>	<u>Description</u>
2	#10 lock washers
3	5/16" x 18 x 5" long screws
3	3/8 lock washer
2	10 x 24 x 1/2" long screw

- **D617 - DP75 Bracket (35mm only)**

- **D628 - "L" adapter panel (35mm / 70mm)** -- used with D617 and breakaway plates.

Used to mount the DTS timecode reader head to the side of the projector. Comes with same hardware as the D614. D628 is used to adapt the D617 for use with the breakaway plates (D628 attaches to D617).

- **D622 - Front Mount Bracket (35mm only)**

Used when installing multiple digital sound heads or when there is not room to lift the projector arm. Used with Dolby SR-D™ and Sony SDDS™ reader heads.

- **5006 0001 00 - Cinemeccanica Bracket / adapter plate (35mm only)**

For Cinemeccanica projectors. Must be used with the D614 standard bracket for mounting the DTS timecode reader head. If the reel arm needs to be remounted, two plates are required.

Note: Cinemeccanica also has their own brackets available. Contact them directly.

- **D626 - Spacer Breakaway Plate** - Used to mount 35mm DTS reader to 35/70 brackets.

- **D627 - Spacer Breakaway Plate** - Used to mount 70mm DTS readers to 35/70 brackets.



DTS Reader Standard Mounting Brackets (next 3 pages)

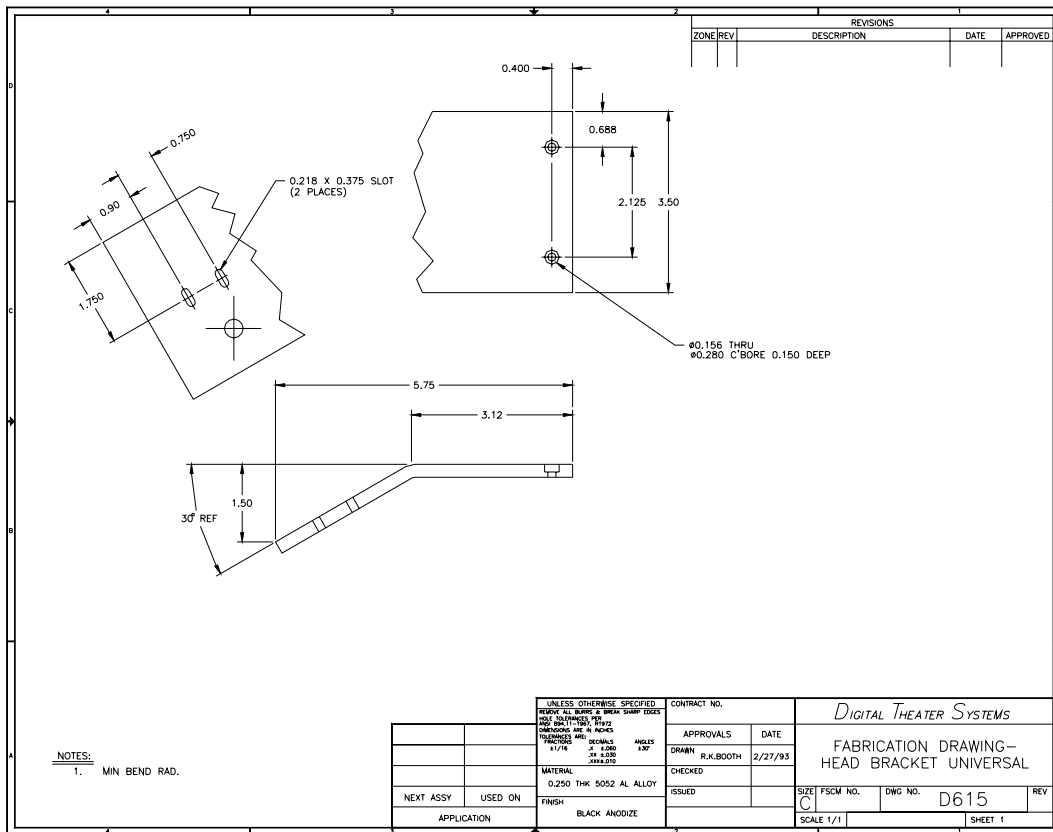
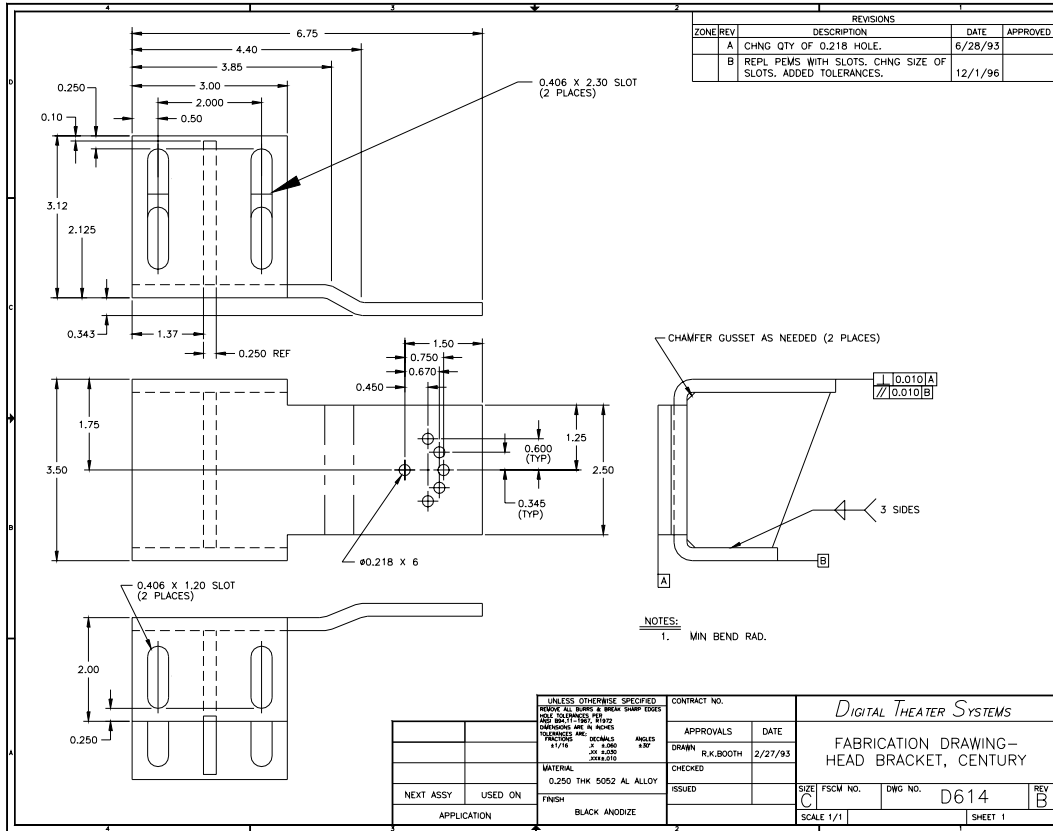

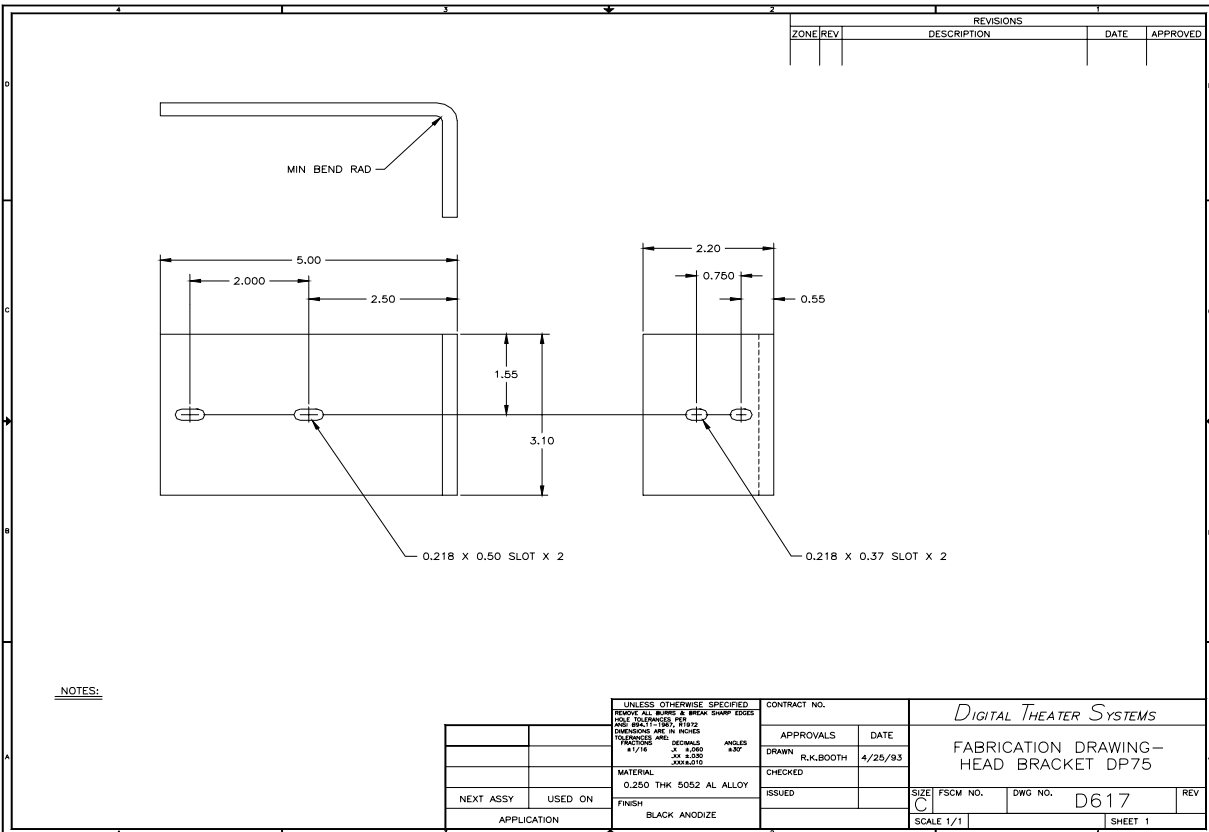
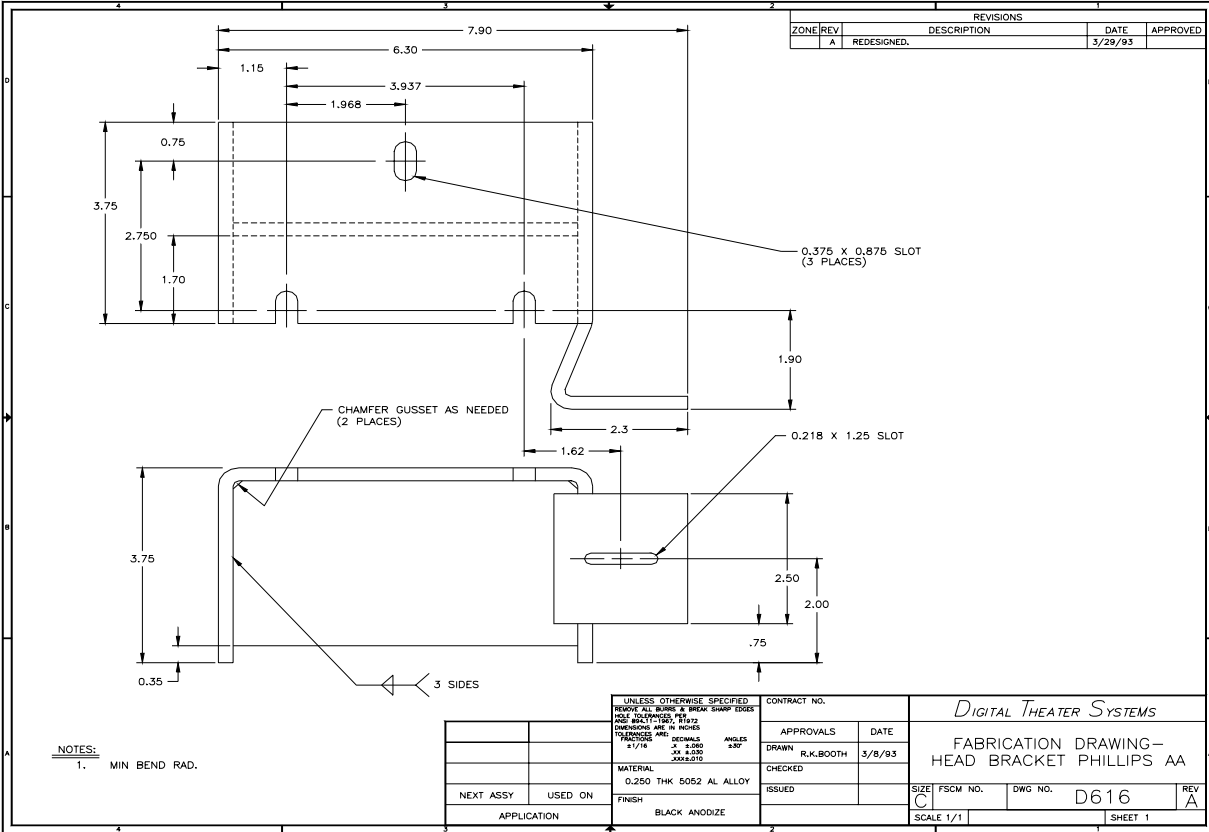

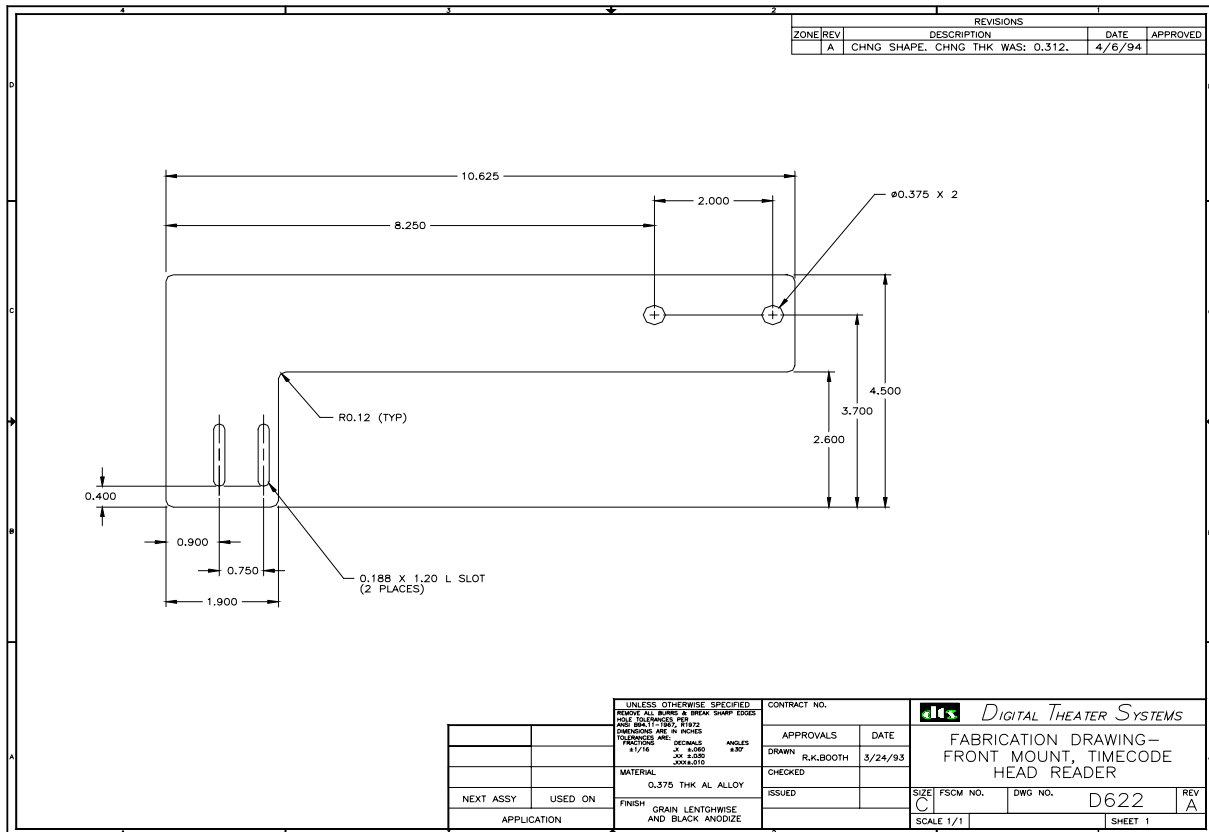
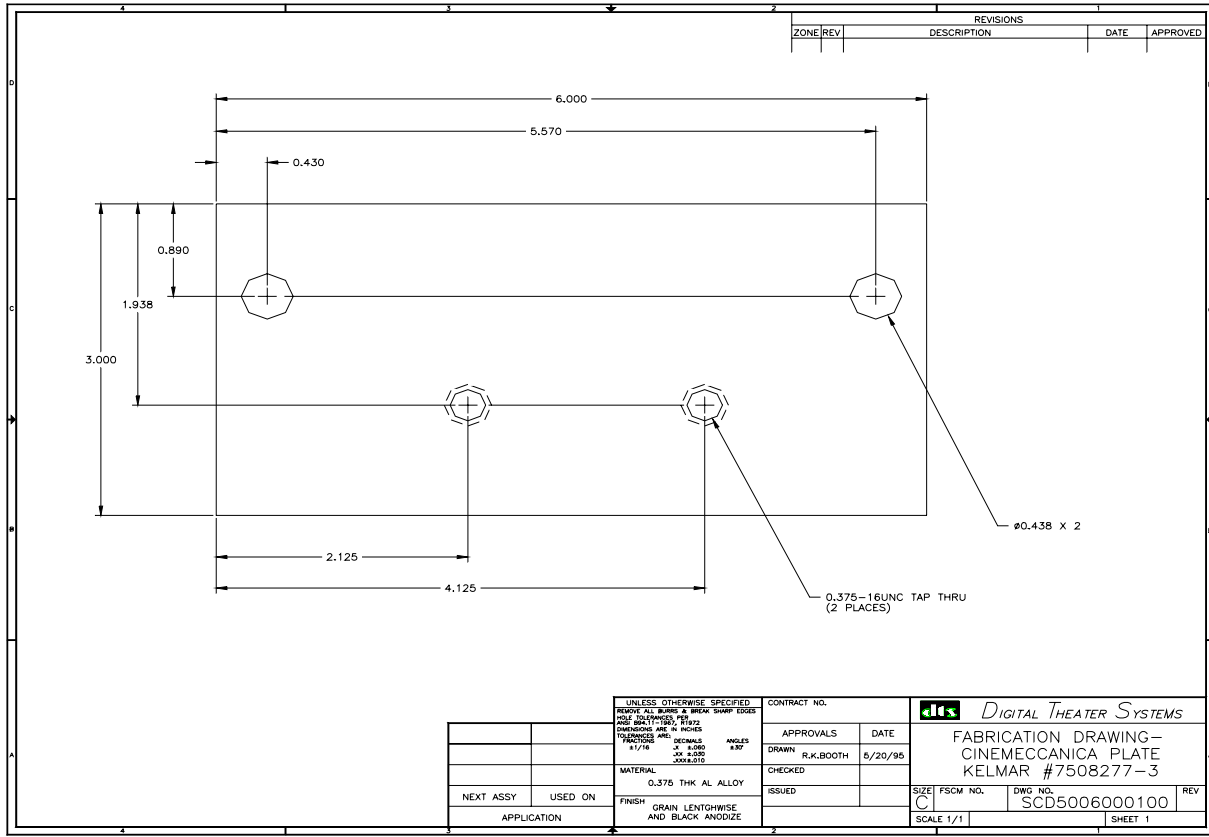

Special mounts/adapters, used for switching between DTS 35mm & 70mm readers (next 3 pages)

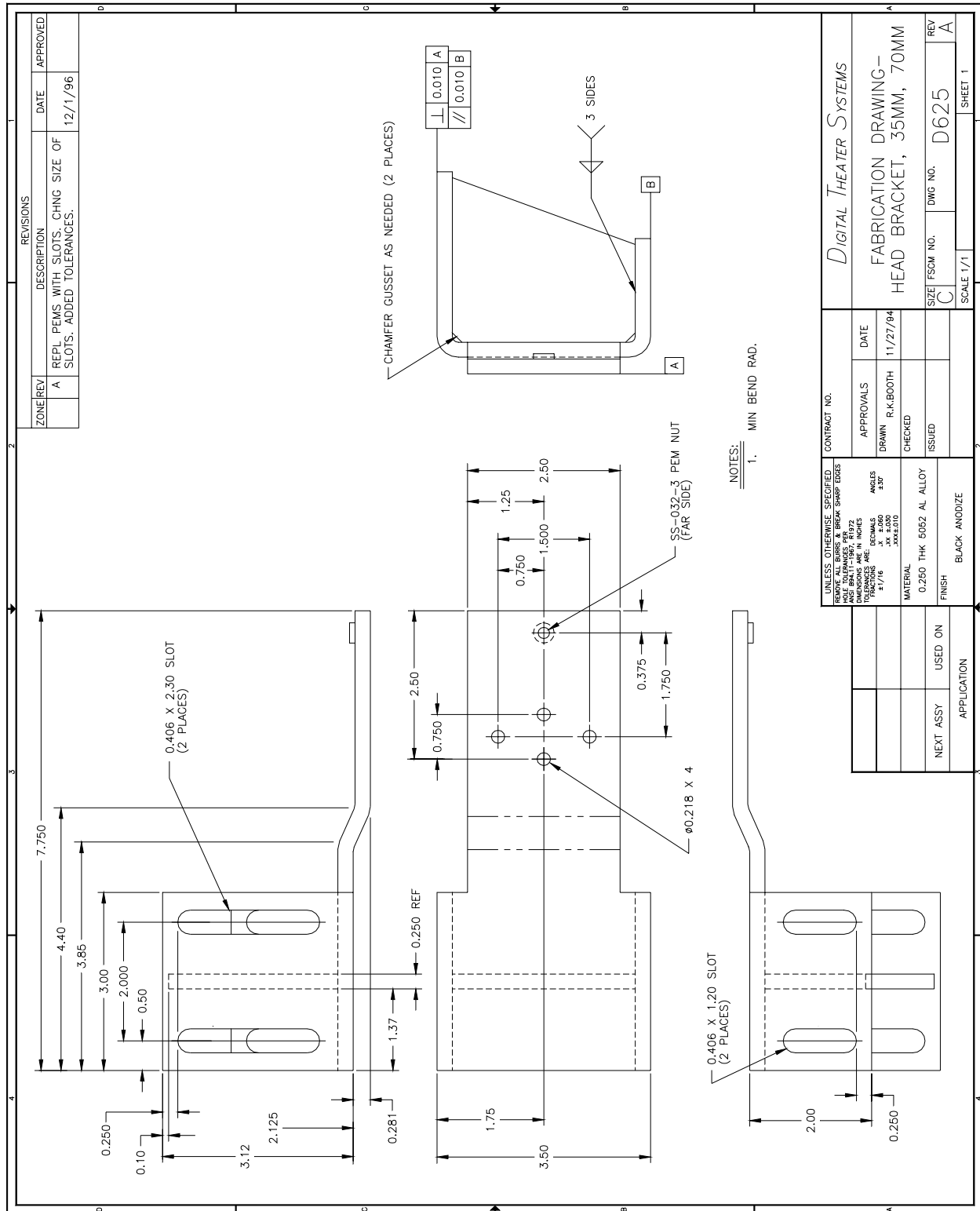

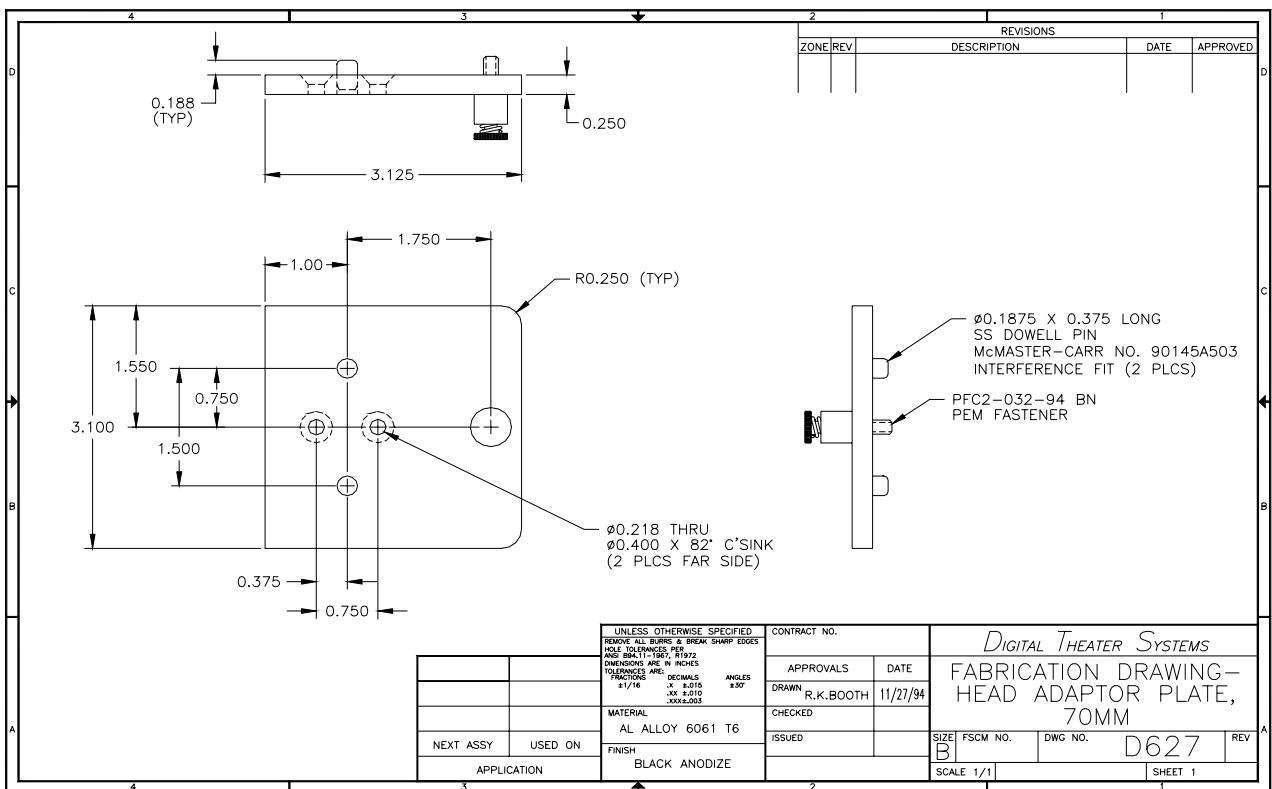
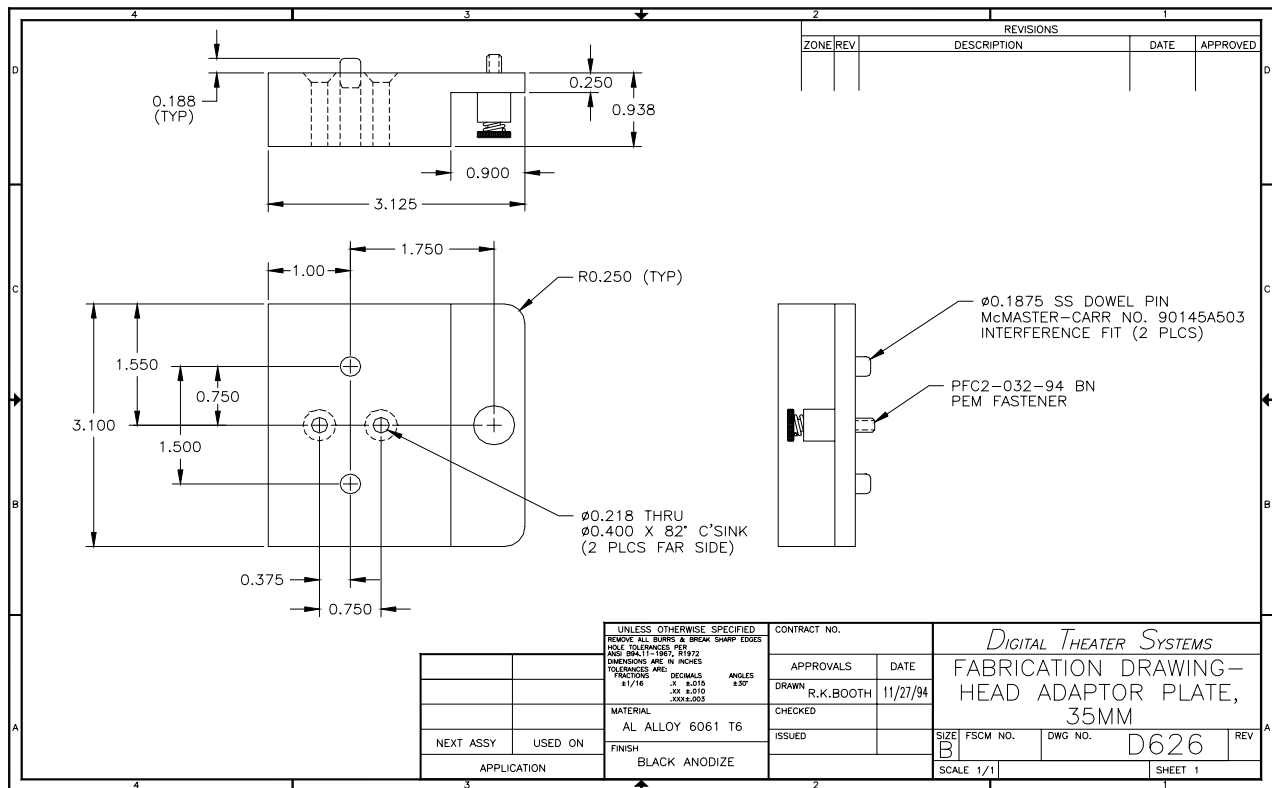

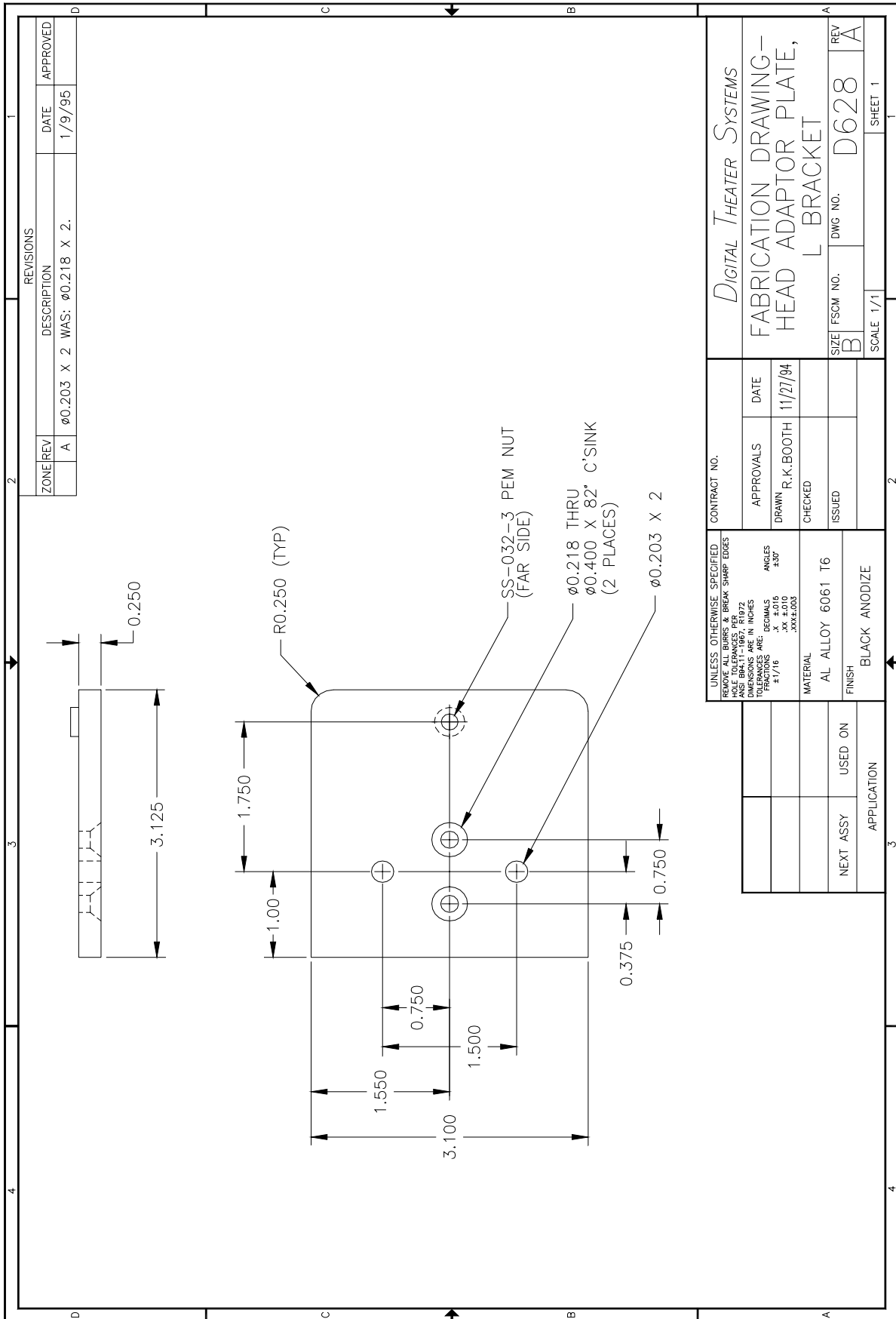

REVISIONS			
ZONE/REV	DESCRIPTION	DATE	APPROVED
A	0.203 X 2 WAS: 0.218 X 2.	1/9/95	

UNLESS OTHERWISE SPECIFIED REMOVE ALL BURRS & BREAK SHARP EDGES HOLE DIA. DIMENSIONS PER HOLE DRILLING SPECIFICATION DIMENSIONS ARE IN INCHES TOLERANCES ARE: DECIMALS .0005 .XX ±0.010 .XXX ±0.005 FRACTIONS ±1/16 ANGLES ±30'		CONTRACT NO. APPROVALS DRAWN R.K. BOOTH CHECKED ISSUED	DATE 11/27/94
MATERIAL AL ALLOY 6061 T6 FINISH BLACK ANODIZE		DIGITAL THEATER SYSTEMS FABRICATION DRAWING- HEAD ADAPTOR PLATE, L BRACKET	
NEXT ASSY APPLICATION		SIZE FSCM NO. B	DWG NO. D628
		SCALE 1/1	SHEET 1

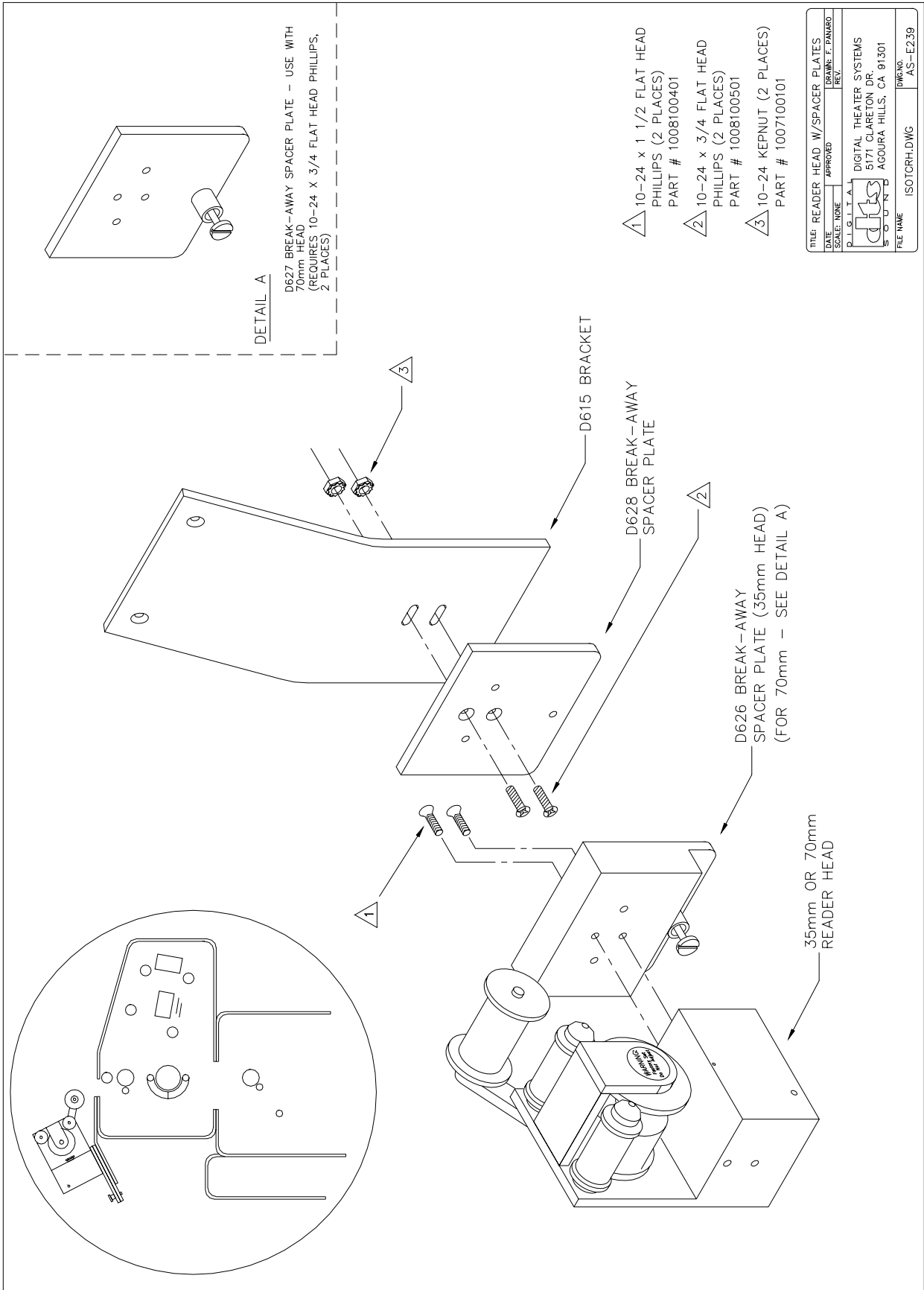

#### 4.5. DTS-CSP, SUBTITLE PROJECTOR, INSTALLATION

The subtitle projector installation consists of three pieces of hardware: ① Projector (DTS-CSP), ② external mask assembly (DTS-EMA), and ③ mounting assembly (DTS P/N 1010 0037 00). Most installations will occur in the projection booth. If no other alternative exists, the projector may be installed in the auditorium.

***The DTS-CSP Subtitle Projector MUST be installed upside down***

#### PRECAUTIONS

Evaluate the area selected for mounting. Special care must be taken when mounting the projector to the wall or ceiling. The mount selected for the subtitle projector should be rated to support 55 Lbs. (25 Kg). Be mindful of and observe basic physical laws that effect balance, stability, and weight distribution.

The optional mount (DTS P/N 1010 0037 00) must be secured to a solid flat surface. Before installing the mount, carefully evaluate the composition and strength of the wall/ceiling. It must be able to support 30 pounds (16.61 Kg). Be sure to provide adequate reinforcement should you determine that it is necessary.

When not using the DTS mount, consult a carpenter to construct appropriate mounting for the DTS-CSP.

Before attaching the mounting plate, drill pilot holes in the ceiling/wall, one for each of the four mounting holes. Drill bit must be smaller than the diameter of the fastener used. The mount manufacturer indicates **fasteners should be 3/8" (9.5mm) in diameter**.

*NOTE: DTS does not provide screws/fasteners for plate to wall/ceiling.*

When attaching the clamp to the DTS-EMA, use the provided 5/16" fasteners in all mounting holes and do not over tighten them. Over tightening can weaken the mounting surface, damage the fasteners, and make the attachment less secure.

A second person is necessary to hold and support the DTS-CSP in place during the tightening procedure.

***When installing subtitle projector, ensure there is easy access for cleaning the lens and changing the lamp.***

##### 4.5.1. INSTALLING THE DTS-CSP IN PROJECTION BOOTH

###### **Tools Required when using DTS P/N 1010 0037 00 (mount)**

- 9/16" socket wrench
- 13/16" and 15/16" open wrenches or medium size adjustable wrench
- Drill with 1/4" (6.3 mm) bit
- Various screwdrivers
- Four 3/8" (9.5mm) in diameter fasteners to attach mounting plate to wall/ceiling, type depends on mounting surface (**mounting fasteners to wall/ceiling NOT provided by DTS**)

**WARNING**   
DO NOT LOOK  
DIRECTLY INTO  
THE LIGHT



#### 4.5.2. MOUNTING PROCEDURE

- If using the DTS P/N 1010 0037 00 mount (also see instructions included with mount):
  - ① Remove clamp assembly from mounting bar (detach from polymer ball).  
Use 9/16" socket wrench to loosen the tension bolt to the clamp until the jaw opens – ONLY enough so that you can release the ball. DO NOT UNSCREW THE TENSION BOLT ENTIRELY
  - ② Drill pilot holes for mounting plate.
    - Using the mounting plate as a template, mark hole locations.
    - Pilot holes must be slightly smaller than 3/8" in diameter.
  - ③ Mount the plate to the wall or ceiling.  
Fasteners must be 3/8" (9.5 mm) in diameter and all four mounting holes must be used. Because the fastener type is dependent on the composition of wall/ceiling, fasteners are not provided by DTS. If you are unsure of fastener type required, consult a carpenter.
  - ⑤ Attach DTS-EMA (external mask/adaptor assembly) to the subtitle projector (see Illustration #1).
  - ④ Attach the projector-mask to the mount (see Illustration #2).
  - ⑥ Attach projector-mask-mount to the clamp (see Illustration #3).
    - Have your assistant orient and hold the projector in place on the mount. You should use the 9/16" socket wrench to tighten the tension bolt to the polymer ball.
    - Watch carefully as the jaw closes on the ball. As you tighten the tension bolt, the only pressure on the ball should be that of the clamp assembly compressing it.
    - Have your assistant support the weight of the projector until the jaw is secure around the ball. Tighten the clamp only enough to lock and hold the projector/adaptor firmly.
  - ⑦ Position the projector and check mounting. (see Illustration #4)  
Since the ball will slowly compress under pressure, you should check the clamp assembly after 15 minutes and tighten again if necessary. Then, check once more after approximately one hour.
- Projector-mask light trims will be adjusted during setup procedure (Section 5).
- Connect cables (see Section 4.9) and proceed to setup (Section 5).

***The subtitle projector MUST be installed upside down***

**Adequate Air Space** (as needed / during operation)

Air space around the unit must be maintained.

- ♦ Minimum clearances are 6" (15.24 cm) either side
- ♦ Flush with the mask front wall in front, 6" (15.24 cm) in back
- ♦ Minimum 12" (30.98 cm) above and below

**WARNING**   
DO NOT LOOK  
DIRECTLY INTO  
THE LIGHT

***All subtitle projector vents and the external blower must not be obstructed in any way***

#### 4.6. INSTALLING NARRATION TRANSMITTER AND CAPTION SYSTEMS

Refer to manufacturer's instructions.

**STEPS FOR INSTALLING THE DTS-CSP IN A PROJECTION BOOTH**

**Illustration #1:** Install mount plate over port-hole window. The four fasteners shown are not provided by DTS, but should be 3/8" (9.5mm) in diameter.

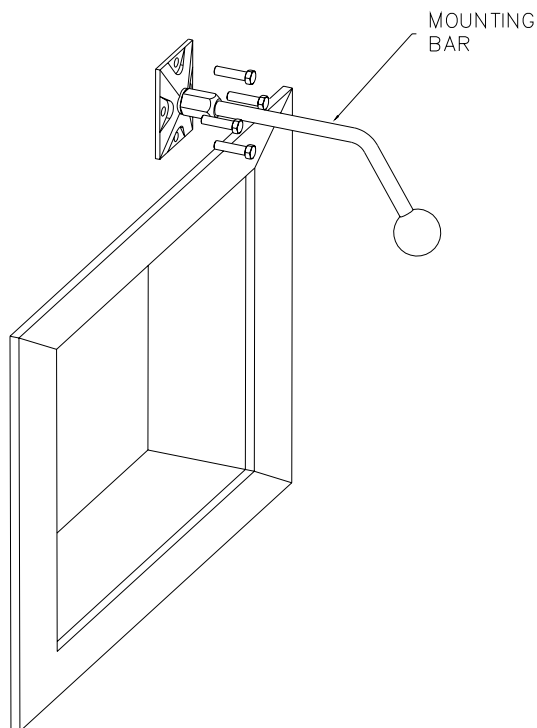

**Illustration #2:** Attach subtitle projector to external mask. The DTS-CSP Subtitle Projector MUST be installed upside-down.

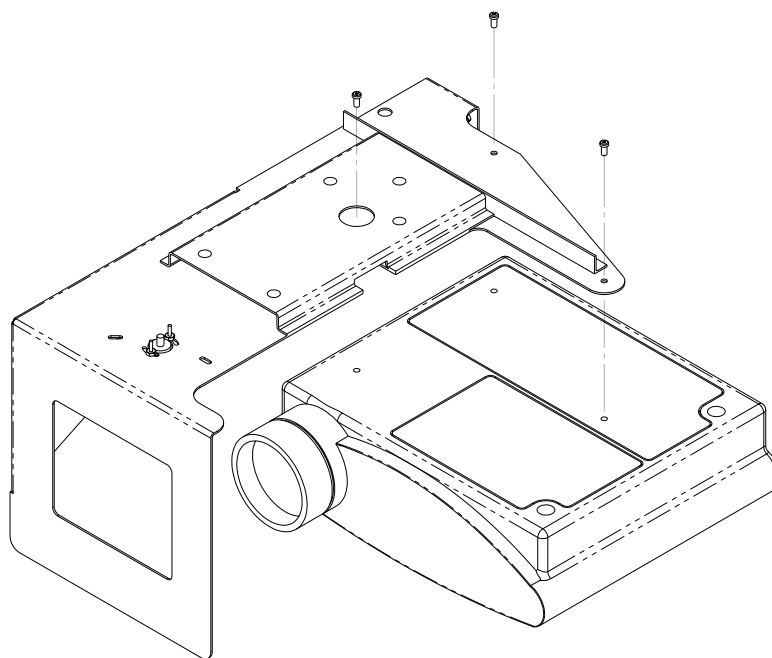

**Illustration #3: Secure projector and external mask to the mount clamp.**

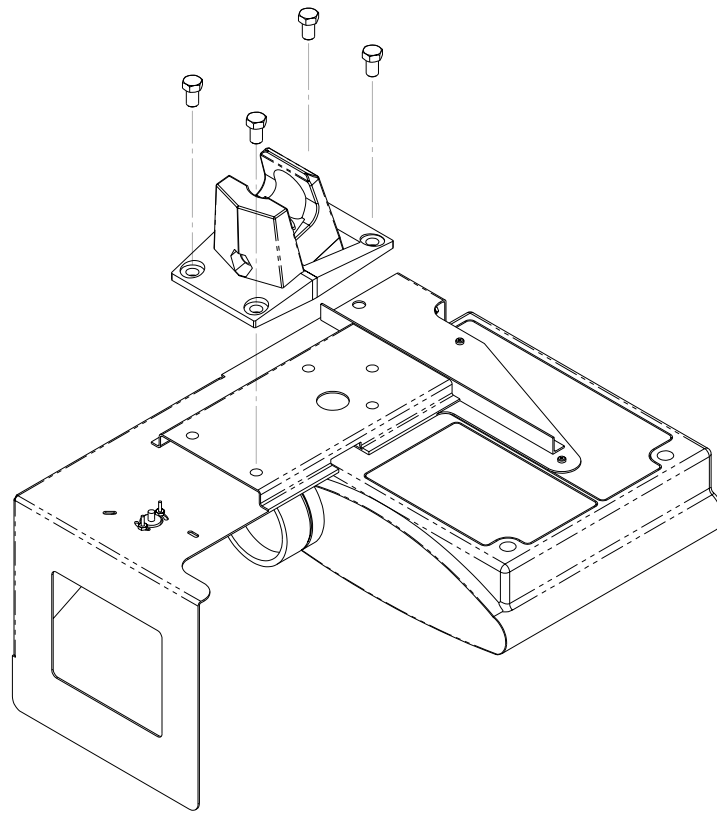

**Now, attach clamp to mount plate.**

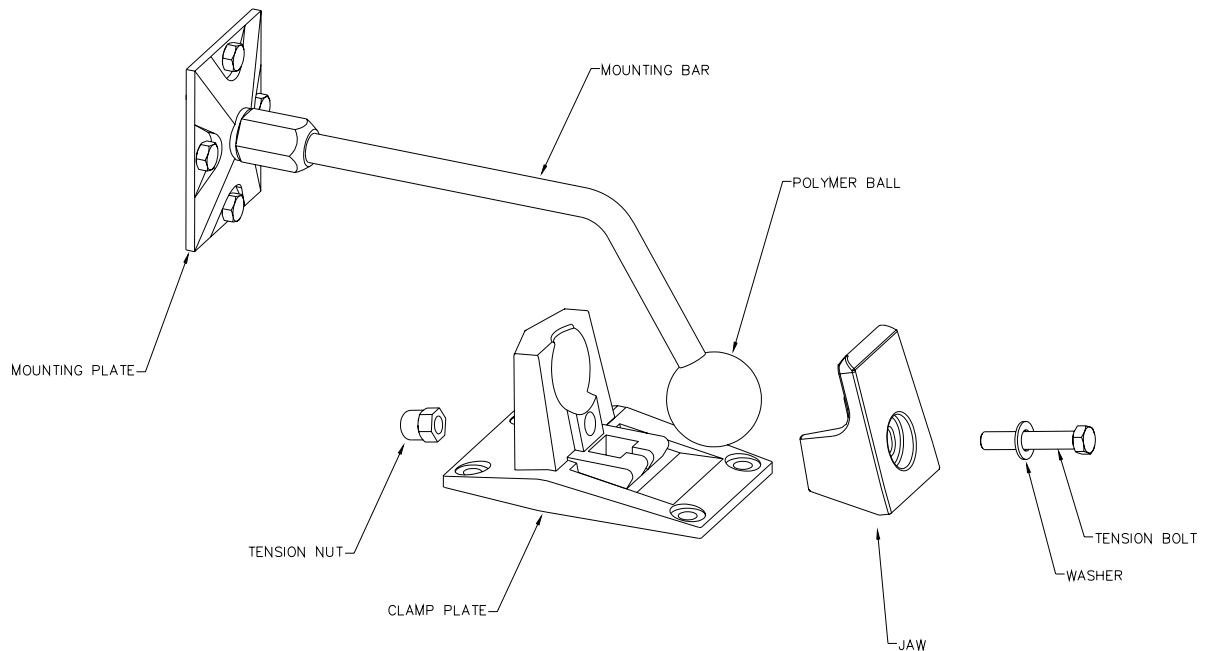

**Illustration #4: Position projector and external mask so that the image on screen is in the correct position. Be sure to tighten clamp once the correct position is determined. See Section 5 to verify image placement and trim positioning.**

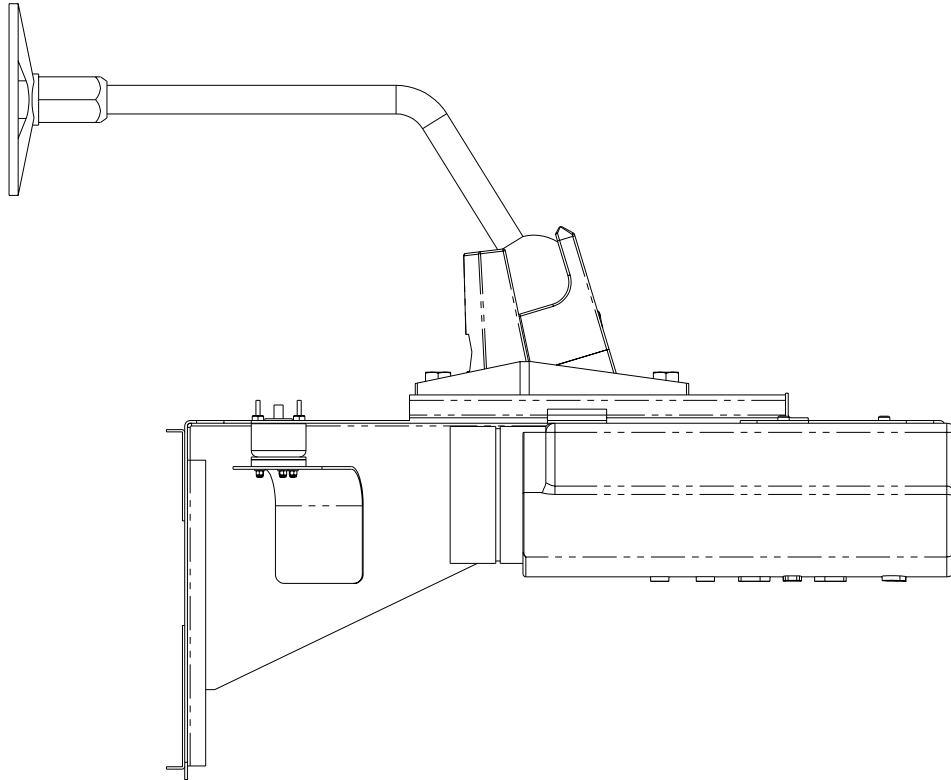

### 4.7. DTS-CSS SYSTEM WIRING DIAGRAMS

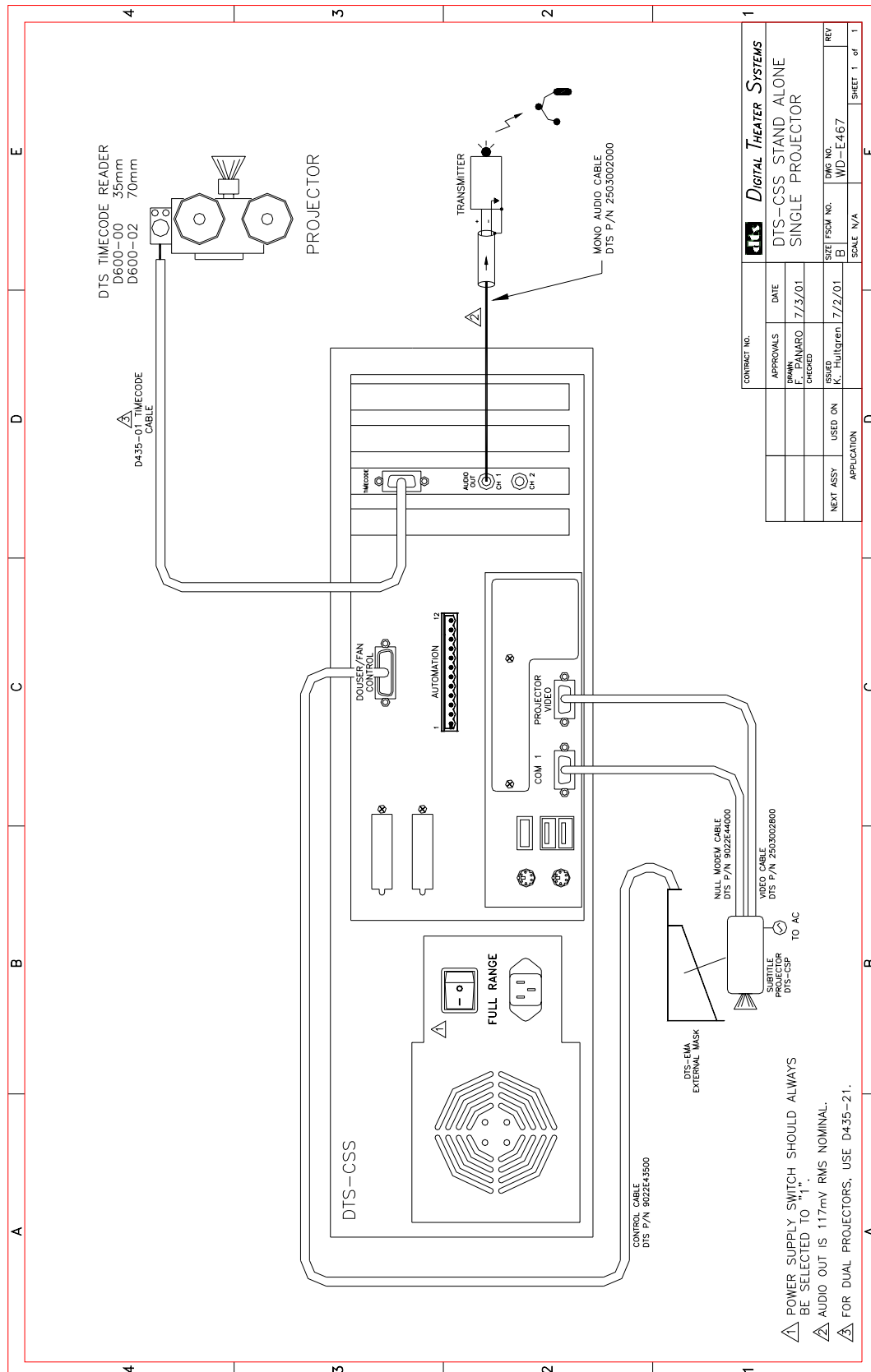

**This page intentionally blank**

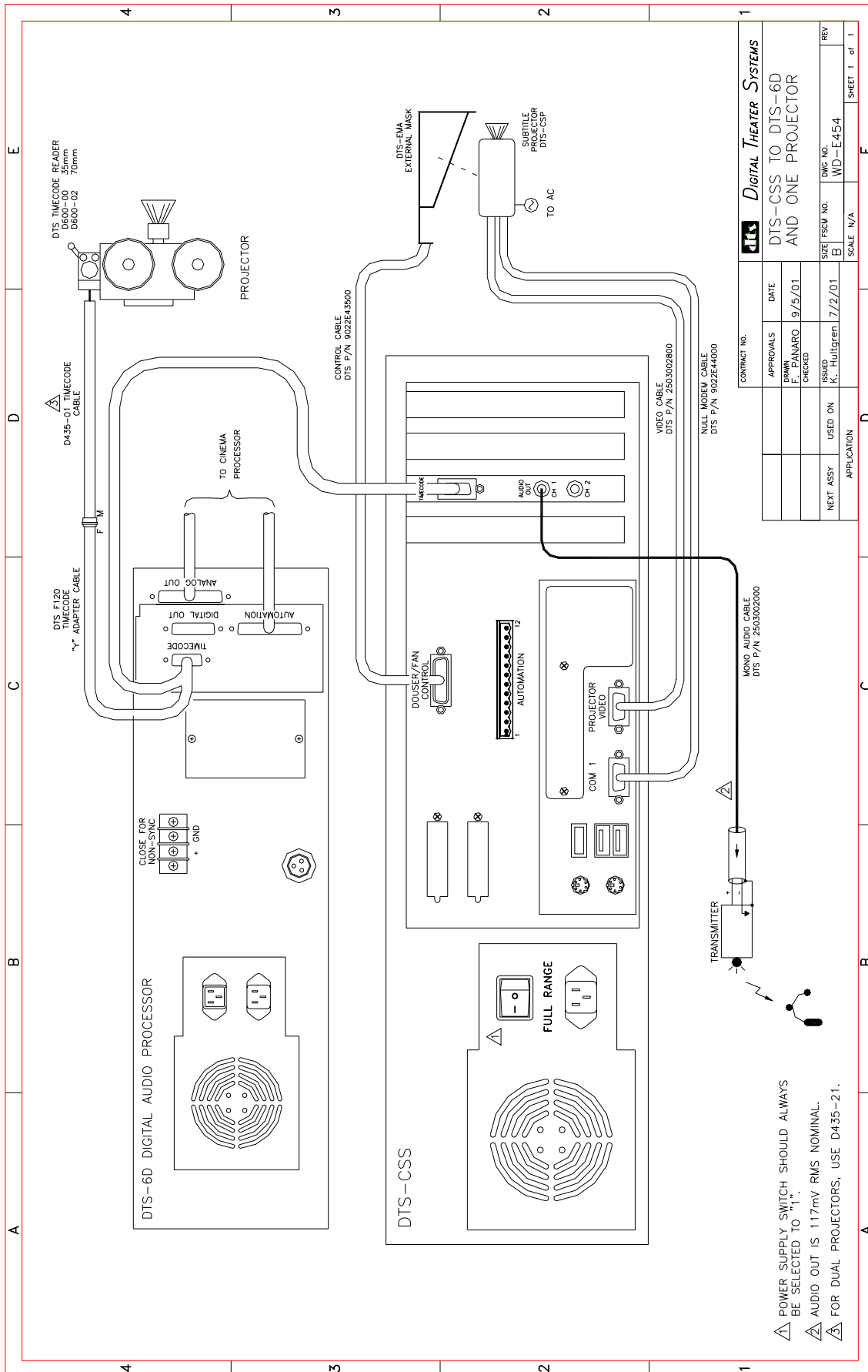

CONTRACT NO.		DTS Digital Theater Systems	
APPROVALS	DATE	DTS-CSS TO DTS-6D AND ONE PROJECTOR	
DRAWN F. PANARO	9/5/01		
ISSUED GREGG			
USED ON K. Hultgren	7/2/01	SIZE B	FORM NO. WD-E454
NEXT ASSY		SCALE N/A	REV 1 of 1
APPLICATION		SHEET 1 of 1	

⚠ POWER SUPPLY SWITCH SHOULD ALWAYS BE SELECTED TO "1".  
 ⚠ AUDIO OUT IS 117mv RMS NOMINAL.  
 ⚠ FOR DUAL PROJECTORS, USE D435-21.

**This page intentionally blank**



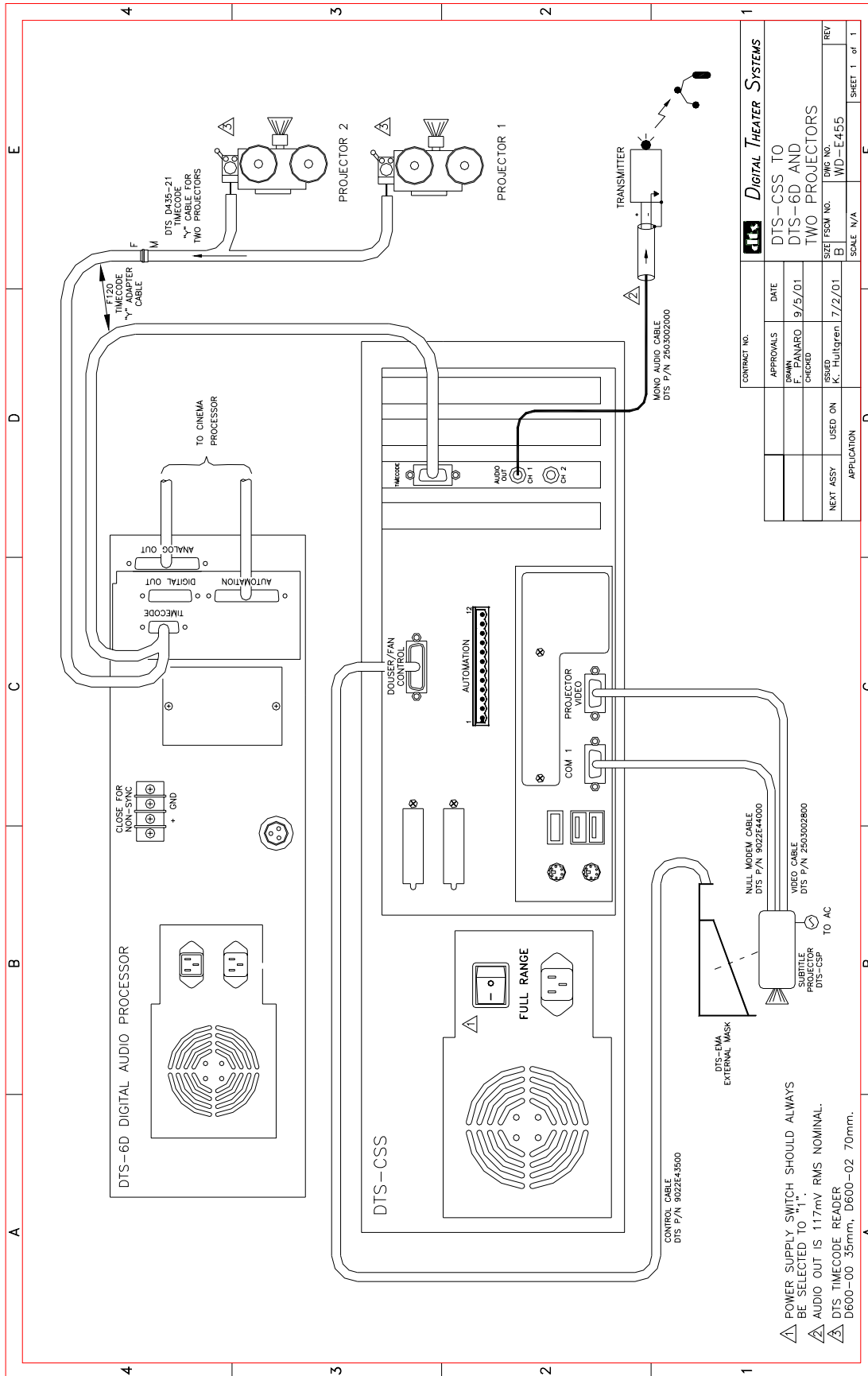

**This page intentionally blank**

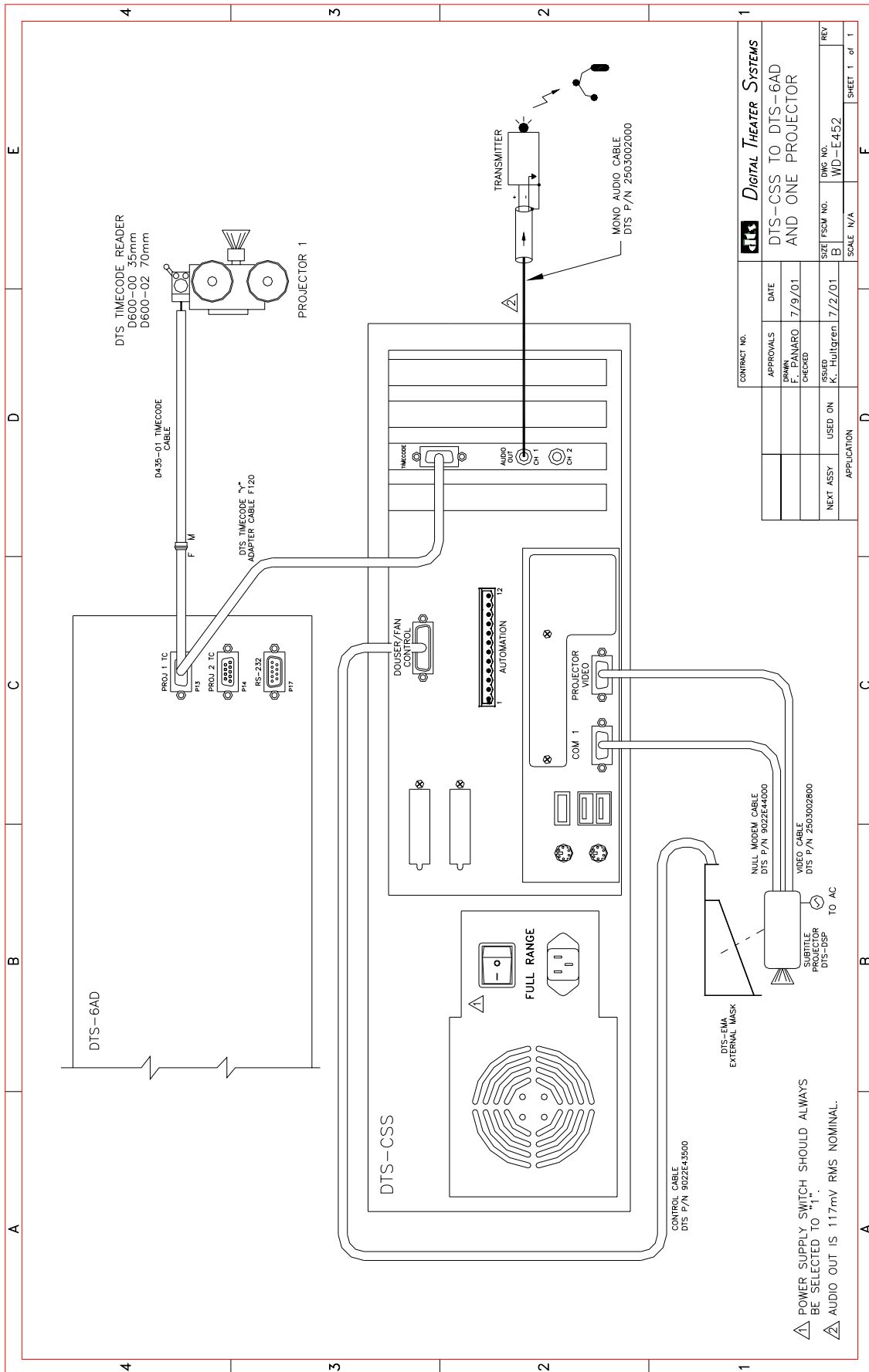

CONTRACT NO.		APPROVALS		DATE	
		DRAWN		7/9/01	
		CHECKED			
NEXT ASSY		USED ON		ISSUED	
				K. Hultgren 7/2/01	
APPLICATION		SIZE		DWC NO.	
		E		WD-E452	
SCALE N/A		SHEET 1 of 1		REV	

**Digital Theater Systems**  
**DTS-CSS TO DTS-6AD AND ONE PROJECTOR**

**This page intentionally blank**

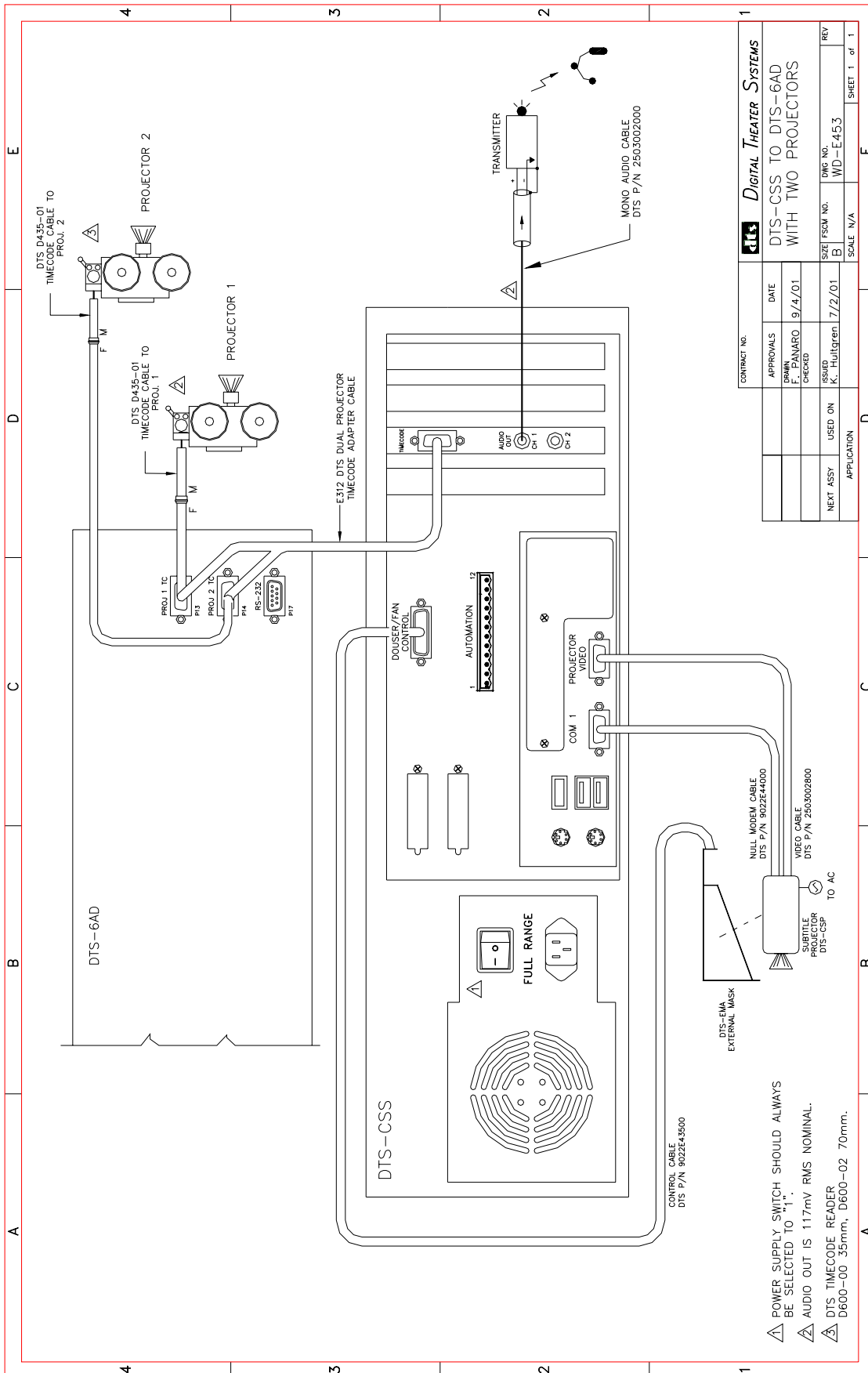

This page intentionally blank

## SECTION 5 SYSTEM SETUP AND PROGRAMMING

### 5.1. SYSTEM SETUP CHECK LIST

Once the DTS-CSS SYSTEM light flashes ready, then perform the steps below:

COMPLETED

- Install system and options (Section 4)
- Determine and program OFFSET value in DTS-CSS (Section 5.2)
- Enable and setup system options
  - SYSTEM OPTIONS
  - NARRATION (Section 5.3)
  - CAPTIONS (Section 5.4)
  - DTS-CSP, SUBTITLE PROJECTOR (Section 5.5)
- Load DTS-CSS show programs (Section 5.6)
- Perform system test (Section 5.8)

### 5.2. DTS-CSS SYSTEM SETUP

This procedure is used to set up a DTS-CSS system. The system may be stand alone or may support the options of narration, captions, and/or subtitles. Choose the option(s) that apply to your system.

#### DTS-CSS UNIT SETUP

##### BOOT-UP

Verify the DTS-CSS back panel power switch is set for “1”. Power on the DTS-CSS by pressing the front panel toggle (power) switch. Wait for it to fully boot-up, indicated by a flashing SYSTEM light. While unit is booting, the display will show the installed software version.

*Display while DTS-CSS is booting up*

```

Loader   V1.00
Initializing, . . .
  
```

← Loader software version

*Main screen after DTS-CSS has booted*

```

DTS-CSS
SN: 00000
R0 00:00:00
  
```

← serial number of show.  
← reel number and time location in reel.

**OFFSET** (setting sync for all options)

The OFFSET is used to synchronize the output of the DTS-CSS narration track and serial commands (subtitles/captions) to the picture projected and the DTS digital soundtrack playing in the auditorium. The **offset value** is dependent on the type of projection equipment used and film size/speed.

- ◆ If a **digital projector**, it is a set value and in most cases, the offset value will be '33'.
- ◆ If it is **film and you are using a DTS Timecode Reader**:
  - And you have a DTS-6 or DTS-6D, the offset value is under the front plate and determined by the position of the OFFSET rotary switches. Enter the same offset value in the DTS-CSS.
  - And you have a DTS-6AD, the offset value is in System Setup "TC RDR OFFSET" (DTS-6AD) Menu. Enter the same offset value in the DTS-CSS.
  - And you do not have a DTS player, see Section 5.2 (in this manual) to calculate the offset value.
- ◆ If it is **film and you are using the DTS Shaft Encoder**, see Appendix B.

### **How To Program The DTS-CSS OFFSET Value**

- Press the ENTER button to access the MAIN MENU.
- Press the ▼ button and scroll to SYSTEM SETUP. Press the ► button
- Once in the SYSTEM SETUP, press the ▼ button and scroll to TC READER OFFSET.
- Press the ► button to go into SET TIMECODE READER OFFSET screen.
- Press the ▲ ▼ buttons to scroll through and select value. Enter the offset value determined in **OFFSET**
- Press the ENTER button to save the setting and return to the main screen.



**DETERMINING DTS READER OFFSET VALUE****• Determining Sync for DTS 35mm film**

Install the 35mm reader head(s). To set sync by *counting frames*, thread 35mm film through the projector and reader. Count the number of frames from the timecode reader head's lens (red LED inside the lens) to the projector's *picture aperture*. Multiply by 1.25 and subtract one. Set the Reader Delay Setting (via display panel menu) to this number.

*EXAMPLE: 27 frames X 1.25 = 33.75 - 1 = 32.75. So, 32.75 would be the delay (offset) value.*

The DTS DEMO REEL (Buzz and Bill Show film) has a specially printed offset leader used to set the reader delay. Start with "00" at the timecode reader head's lens (red LED inside lens) and thread through the projector. Read the number at the projector's optical sound head and set the DTS player's delay (offset) to that number.

**The delay (offset) value must be between "15" and "99". If it is not within these parameters, relocate the reader head(s) on the projector(s) until a valid number is achieved**

**• Determining Sync for DTS 70mm (5-perf) film**

**NOTE: The DTS DEMO FILM cannot be used to set the delay or test the 70mm reader.**

Install the 70mm reader head(s). To set sync by *counting frames*, thread 70mm film through the projector and reader. Count the number of frames from the timecode reader head's lens (red LED inside the lens) to the projector's *picture aperture*. Multiply by 1.25 and subtract one. Set the Reader Delay Setting (via display panel menu) to this number.

*EXAMPLE: 27 frames X 1.25 = 33.75 - 1 = 32.75. So, 32.75 would be the delay (offset) value.*

There is a special DTS 70mm offset leader available, P/N 6800-000-02. This leader is used to measure reader delay for 70mm film only. Start with "00" at the Timecode Reader Head's lens (red LED inside the lens) and thread the leader through the projector. Read the number at the projector's picture aperture. This is the delay (offset) value. Set the DTS player's delay (offset) to that number.

The offset number must be between "15" and "99". If the offset is not within these parameters, relocate the reader head(s) on the projector(s) until a valid number is achieved

*When threading the projector, make the same size film loops measuring the offset as when running a movie. Failure to do so will result in improper sync when the movie runs in DTS digital sound.*

**• When using both the DTS 35mm and DTS 70mm timecode readers with one DTS player.**

Perform the steps above. The offset setting for the 35mm and the 70mm reader will not be the same. *Remember to change the delay (offset) setting (on the DTS player) when changing between 35mm and 70mm timecode reader heads.*

**For quick reference, use indelible ink and write down the 70mm and 35mm offset settings on masking tape. Attach the masking tape to the DTS timecode reader head mounting bracket.**

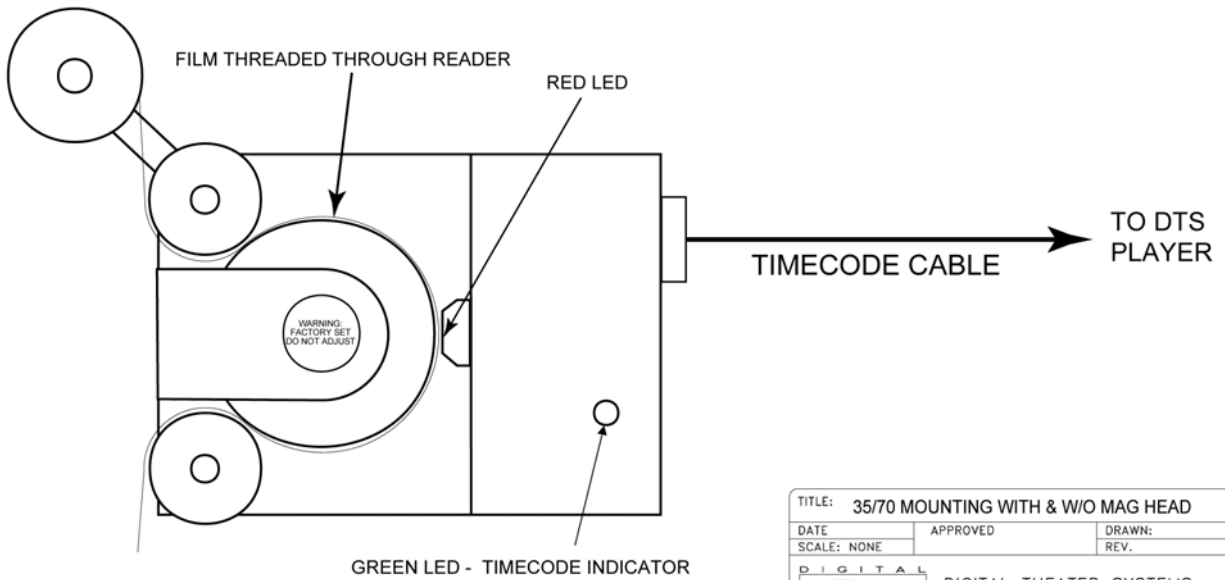
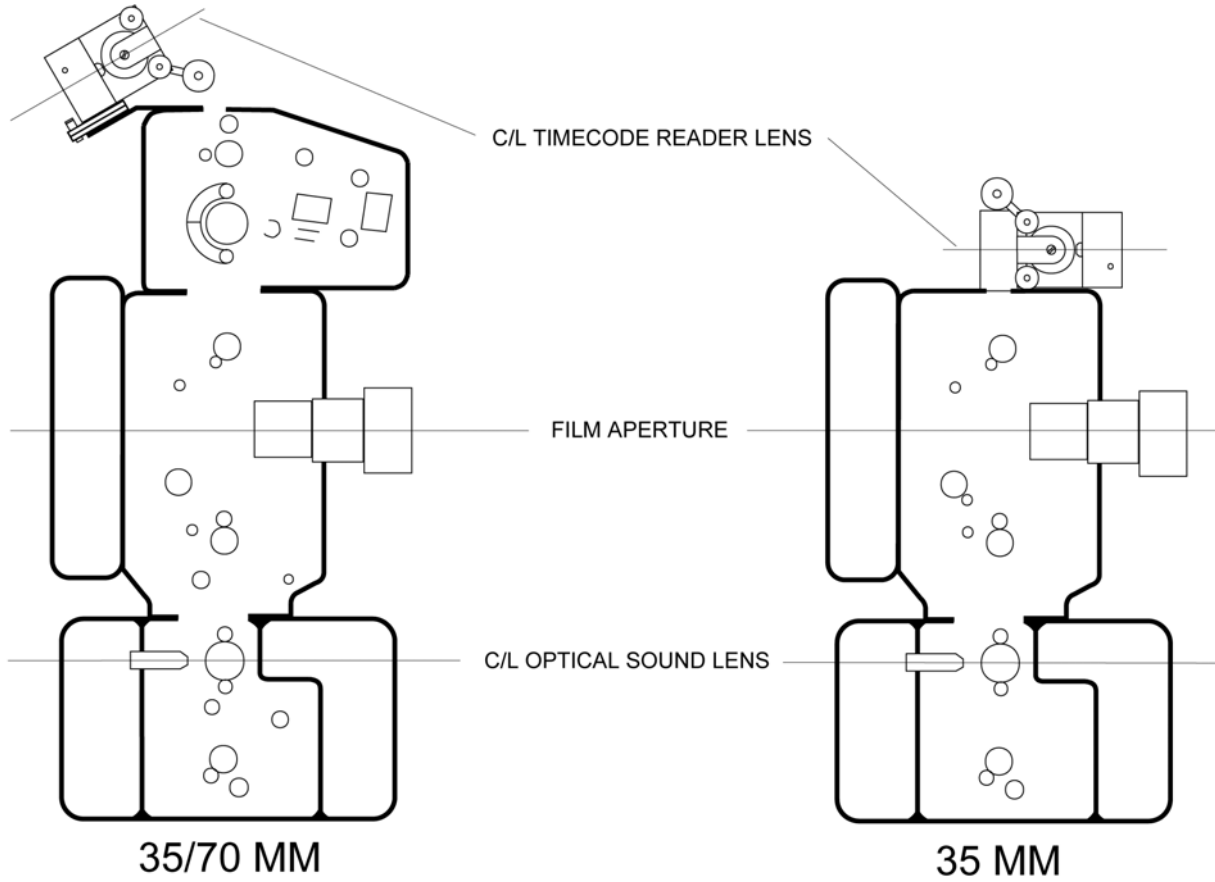

TITLE: 35/70 MOUNTING WITH & W/O MAG HEAD		
DATE	APPROVED	DRAWN:
SCALE: NONE		REV.
 DIGITAL THEATER SYSTEMS 5171 CLARETON DR. AGOURA HILLS, CA 91301		
FILE NAME	DWG. NO.	
TIE245A (3570MAG).AI	TI-E245	

### 5.3. NARRATION OPTION SETUP

*Equipment Required: Volt Meter and “Buzz and Bill Show” DTS Demo film.*

Start by disconnecting the “AUDIO OUT” cable from the transmitter.

- On the DTS-CSS, press the ENTER button to access the MAIN MENU.
- Press the ▼ button and scroll to SYSTEM SETUP. Press the ► button
- Once in SYSTEM SETUP, press the ▼ button and scroll to TEST MODE..
- Once in TEST MODE MENU, press the ▼ button and scroll to SELF PLAY. Press the ► button
- Once in SELF PLAY MENU, press the ▼ button and scroll to “1K @ -20dB FS”. Press the ENTER button
- Now that the test tone is enabled, the DTS-CSS should output a 1K Hz reference tone on the narration output line. Use a volt meter and verify **117mV RMS ± 10mV** at the “AUDIO OUT” connector.
- Once output verified, press ▼ button (SELF PLAY MENU) and scroll to “**Buzz And Bill**”. Press ENTER button.
- Connect the DTS-CSS “AUDIO OUT” cable to the transmitter. The test voice should now be fed from the DTS-CSS to the transmitter. The test voice should be heard in the headsets.
- Once tests are completed, press the ▼ button (SELF PLAY MENU) and scroll to EXIT. Press the ENTER button.
- No sound should be heard in the headsets and you should have returned to the main screen.
- Thread the “Buzz and Bill Show” demo film and run it. Verify narration is heard in sync with action on-screen.

### 5.4. CAPTION OPTION SETUP

*Equipment Required: “Buzz and Bill Show” DTS Demo film.* This procedure is for the Rear Window™ Captioning System.

#### Enable the Caption Option

- On the DTS-CSS, press the ENTER button to access the MAIN MENU.
- Press the ▼ button and scroll to SYSTEM SETUP. Press the ► button
- Once in SYSTEM SETUP, press the ▼ button and scroll to COM1 CONFIGURATION, press the ► button.
- Once in COM1 CONFIGURATION, press the ▼ button and scroll to REAR WINDOW.
- Press the ENTER button to enable and save setting.
- Press the ▼ button and scroll to EXIT. Press the ENTER button to return to the main screen.

#### Test the Caption Option

- On the DTS-CSS, press the ENTER button to access the MAIN MENU.
- Press the ▼ button and scroll to SYSTEM SETUP. Press the ► button
- Once in SYSTEM SETUP, press the ▼ button and scroll to TEST MODE. Press the ► button
- Once in TEST MODE MENU, press the ▼ button and scroll to SELF PLAY. Press the ► button
- Once in the SELF PLAY MENU, press the ▼ button and scroll to **Buzz And Bill**.
- Press the ENTER button to start the test.
- When the “captions” play, verify a test pattern is displayed on the rear window screen. Remember that it will be in mirror-image. Now, sit in an auditorium seat and position the Plexiglas viewer to see the captions. Verify the captions are clear and easy to read.

- Once the captions are verified, press ▼ button and scroll to EXIT. Press ENTER button to exit and return to the main screen.
- Thread the “Buzz and Bill Show” demo film and run it. Verify captions are seen in sync with action on-screen.

## 5.5. SUBTITLE PROJECTOR OPTION SETUP

### Enable the Subtitle Projector Option

- On the DTS-CSS, press the ENTER button to access the MAIN MENU.
- Press the ▼ button and scroll to SYSTEM SETUP. Press the ► button
- Once in SYSTEM SETUP, press the ▼ button and scroll to COM1 CONFIGURATION, press the ► button.
- Once in COM1 CONFIGURATION, press the ▼ button and scroll to SUBTITLE PROJECT.
- Press the ENTER button to enable and save setting.
- Exit and return to the main screen. Now, setup the DTS-CSP subtitle projector.

### 5.5.1. DTS-CSP SUBTITLE PROJECTOR SETUP

*Equipment Required: Light meter*

#### Verify film projector light

Using a light meter, verify the film projector's light reflected off the screen. Adjust to the industry standard. Verify the light fills the screen evenly. Consult manufacturer when making adjustments to the lamp house.

**After the light reading is finished, close the film projector's douser.**

### PROGRAMMING FOR THE DTS-CSP SUBTITLE PROJECTOR

Remove the lens cap and press the green ☀ **POWER** button to power on the DTS-CSP, subtitle projector.

#### **Verify Lamp Life Counter**

- On the DTS-CSS, press the ENTER button to access the MAIN MENU.
- Press the ▼ button and scroll to PLAYBACK SETUP, then press the ► button.
- Once in PLAYBACK MENU, press the ▼ button and scroll to CURRENT LAMP HOURS.
- Press the ► button to view lamp life hours. It should be at [ 0 ] If not at zero, see Section 7.4.4, step 11 to reset DTS-CSP subtitle projector lamp hour counter.
- Press ENTER button to keep selection and return to the main screen.

#### **Set the Light Intensity of the DTS-CSP, subtitle projector**

- Press ENTER to access the MAIN MENU.
- Press the ▼ button and scroll to SYSTEM SETUP. Press the ► button.
- Once in SYSTEM SETUP, press the ▼ button and scroll to PROJECTOR SETUP. Press the ► button.
- Once in the PROJECTOR MENU, press the ▼ button and scroll to LIGHT INTENSITY. Press the ► button
- Once in LIGHT INTENSITY, press the button to scroll to “Normal”. Press ENTER button.
- Press the ▼ button and scroll to EXIT. Press ENTER button to keep selection and return to the main screen.

**Check the Light Output of the DTS-CSP Subtitle Projector**

- From the main screen, press ENTER to access the MAIN MENU.
- Press the ▼ button and scroll to SYSTEM SETUP Press the ► button.
- Once in SYSTEM SETUP, press the ▼ button and scroll to PROJECTOR SETUP. Press the ► button.
- Once in the “Projector Menu”, press the ▼ button and scroll to TEST PATTERNS. Press the ► button.
- Once in TEST PATTERN, use the ▼ button to scroll to “White”. Press ENTER button.
- Verify the DTS-EMA shutter automatically opens.
- With the light meter, measure the light reflected off the screen. Use the table below.

<u>Distance from screen</u>	<u>“Normal” power (DTS-CSP)</u>
20 Ft. (6.1 meters)	32 to 26 FL
30 Ft. (9.1 meters)	14 to 11 FL
40 Ft. (12.2. meters)	8 to 6.4 FL
50 Ft. (15.2 meters)	5 to 4 FL

- Return to TEST PATTERN and this time choose EXIT. Press the ENTER button. Verify the DTS-EMA shutter automatically closes.

**Adjust the Subtitle Picture Quality**

- While in TEST PATTERN, press ▼ button and scroll to “FULL SCREEN”. Press ENTER button.
- Remove any screen masking.
- Once test pattern is on the screen, adjust the DTS-CSP zoom and focus.

**Adjust DTS-CSP zoom**

Zoom the projector in or out by rotating the zoom ring. The test grid pattern should fill the entire screen. It should be level, centered and extend to both sides of the screen.

**Adjust DTS-CSP focus**

Focus projector by rotating the focus ring. The text grid pattern should have crisp edges and be easy to read.

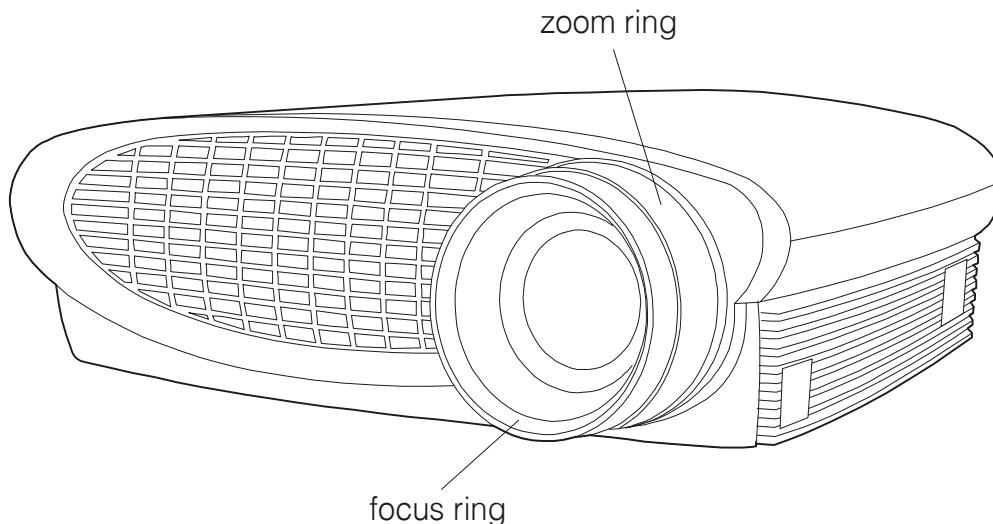

**Aim the DTS-CSP Subtitle Projector** (with screen masking removed)

- From the MAIN MENU, press the ▼ button and scroll to SYSTEM SETUP. Press the ► button.
- Press the ▼ button and scroll to PROJECTOR SETUP. Press the ► button.
- Once in the “Projector Menu”, press the ▼ button and scroll to TEST PATTERN.
- Once in TEST PATTERN, use the ▼ button and scroll to “Full Screen”. Press ENTER button.
- Verify the test grid pattern is centered on the screen, it will encompass the entire screen area.
- Now, go back into TEST PATTERN and this time choose the “View Area”. Press ENTER button  
You have two choices: Horizontal View Area -or- Vertical View Area. Choose one that matches the subtitle format used by the theater.
- Verify the white box test pattern covers the intended “subtitle area” shown below.

**The DTS-CSP subtitle projector must be installed upside down, as shown below.**

*HORIZONTAL SUBTITLES*

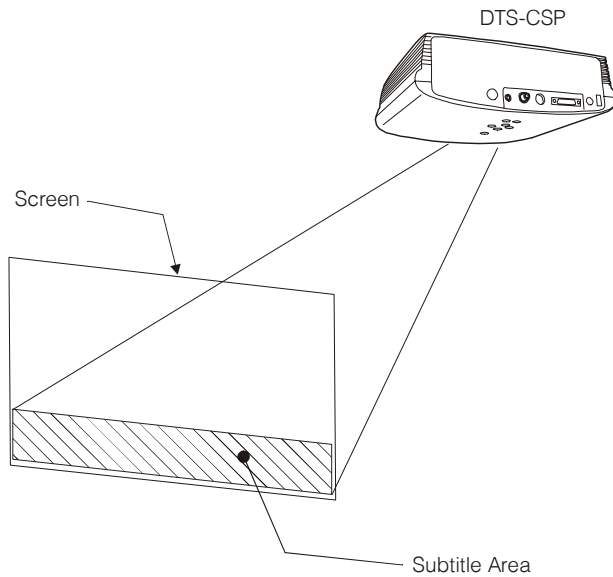

*VERTICAL SUBTITLES*

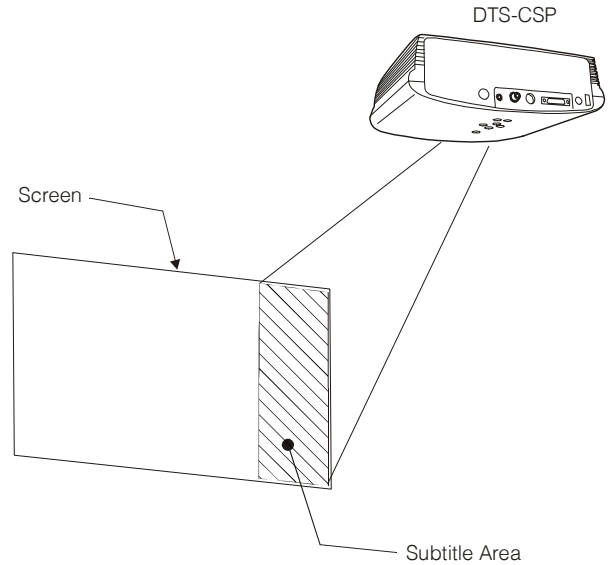

**5.5.2. Position the DTS-EMA Mask Trims** (with screen masking added)

You have two choices: *Vertical or Horizontal*. Theater must be setup for one or the other, not both.

Vertical Subtitles

- While in TEST PATTERN, press ▼ button and scroll to VERTICAL MASK. Press ENTER button.
- Add screen masking. The white box test pattern should be seen in the vertical subtitle area, shown below. Adjust the DTS-EMA magnetic trims to block out any extraneous light.

Horizontal Subtitles

- While in TEST PATTERN, press ▼ button and scroll to “SCOPE MASK”. Press ENTER button.
  - Adjust the DTS-EMA magnetic trims so that white box test pattern fits in the horizontal subtitle area.
- The magnetic trims are used to block out any extraneous light at the DTS-EMA. You will receive -1- large, -1- medium, and -2- small trims. Position them as needed so that only the intended “subtitle area” is lit by the test pattern.*
- **Start with SCOPE. Be sure to adjust screen masking to scope.**

**BEFORE**

**AFTER**

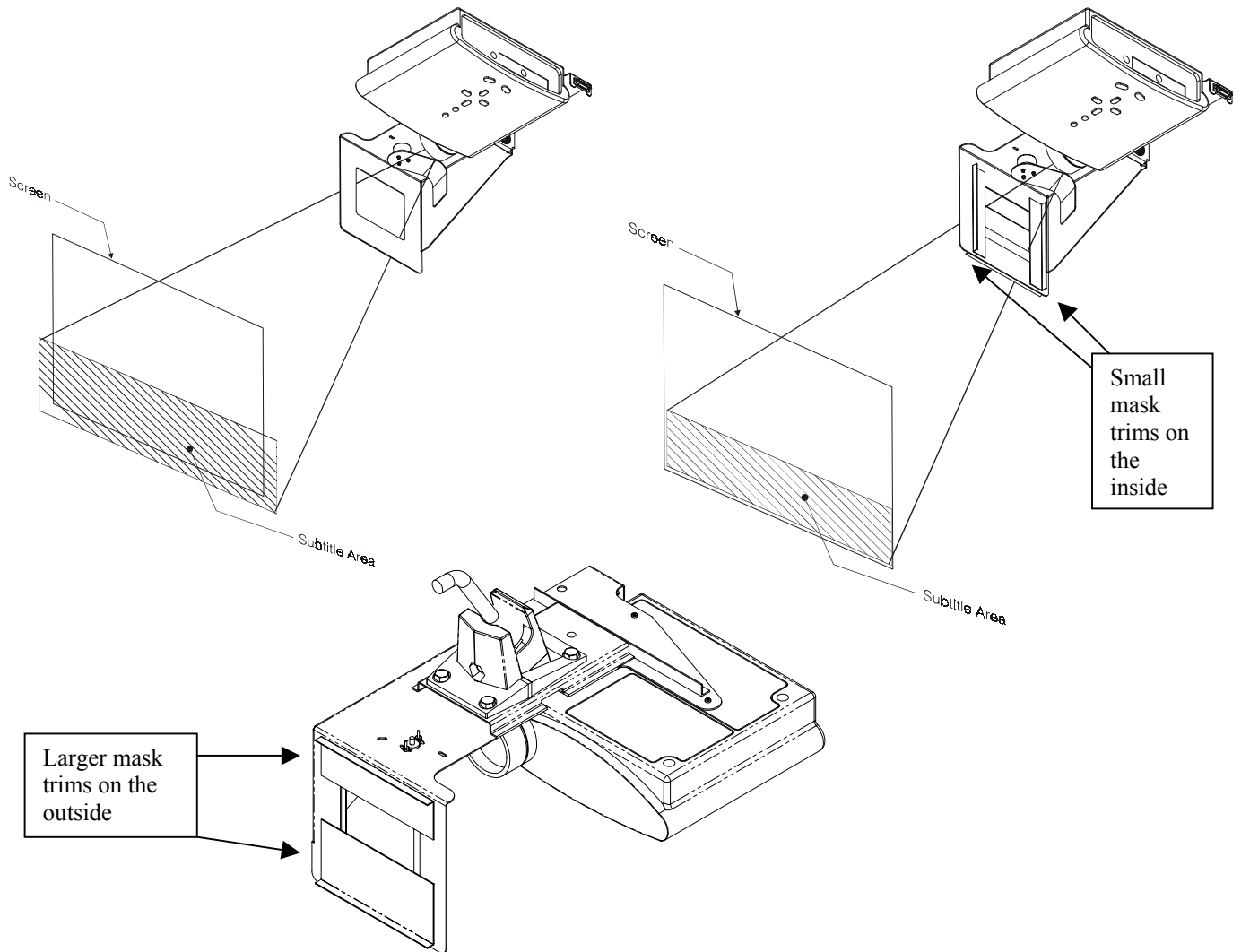

**Once mask trims are set, now choose “Mask-Flat” and make any necessary adjustments to mask trims so that both picture formats are accommodated. Be sure to adjust screen masking for flat.**

### 5.5.3. Position and Refine Subtitle Image On-Screen

#### Enable Subtitle Demo

- From SYSTEM SETUP, press the ▼ button and scroll to TEST MODE. Press the ► button
- Once in the TEST MODE MENU, press the ▼ button and scroll to SELF-PLAY. Press the ► button.
- Once in SELF PLAY MENU, press the ▼ button and scroll to **BUZZ And BILL**. Press the ENTER button.

#### Set Flat Position

- From PROJECTOR MENU, press the ▼ button
- Press the ▼ button and scroll to VERT OFFSET-Flat. Press the ► button.
- **Set the screen masking for flat.**
- Press the ▲ ▼ buttons to scroll to desired values, then press ENTER button to enable selection. After ENTER is pressed, the test pattern will move. Once test pattern centered, press ENTER button to save setting.

#### Set Scope Position

- From PROJECTOR MENU, press the ▼ button
- Press the ▼ button and scroll to VERT OFFSET-Scope. Press the ► button.
- **Set the screen masking for scope.**
- Press the ▲ ▼ buttons to scroll to desired values, then press ENTER button to enable selection. After ENTER is pressed, the test pattern will move. Once test pattern centered, press ENTER button to save setting.

#### Set Font Size

*This menu allows you to select the best subtitle font size for your particular screen.*

- From the SYSTEM SETUP, press the ▼ button and scroll to PROJECTOR SETUP. Press the ► button
- Once in PROJECTOR MENU, press the ▼ button and scroll to FONT SIZE. Press the ► button.
- Press the ▼ button to scroll and select “Normal” by pressing the ENTER button. A star should appear next to the selection. Example: (\*) Normal.
- Press the ENTER button to save.

#### Verify Focus

While subtitles are on-screen, verify DTS-CSP projector focus setting and make any necessary adjustments.

#### Disable Subtitle Demo

- From SYSTEM SETUP, press the ▼ button and scroll to TEST MODE. Press the ► button
- Once in the TEST MODE MENU, press the ▼ button and scroll to EXIT. Press the ENTER button.

### 5.5.4. Final Programming

#### **Enable User Selectable Languages**

*After the DTS-CSP has been setup, determine which subtitle languages will be selectable by the projectionist.*

- From SYSTEM SETUP, press the ▼ button and scroll to LANGUAGES. Press the ► button
- While in AVAILABLE LANGUAGES, press the ▲ ▼ buttons the scroll through language choices. Press ENTER to enable languages. Repeat until all needed languages are enabled = Example: [\*} English
- After completing selections, scroll to EXIT and press the ENTER button to return to the main screen.



### Setting Startup Option

*This sets the unit to be setup locally or externally.*

- From the MAIN MENU, press the ▼ button and scroll to SYSTEM SETUP. Press the ► button.
- Press the ▼ button and scroll to STARTUP OPTIONS. Press the ► button.
- Verify **FAST STARTUP** has been chosen. Example: (\*) FAST STARTUP. If something else is enabled, press the ► button and then press the ENTER button..
- After completing selection, scroll to EXIT and press the ENTER button to return to the main screen.

### Setting Password

*This is used to lock unauthorized people out of SYSTEM SETUP. A password is recommended but not required..*

- From the MAIN MENU, press the ▼ button and scroll to SYSTEM SETUP. Press the ► button.
- Press the ▼ button and scroll to SET PASSWORD. Press the ► button.
- Once in “Password” press the ▲ ▼ buttons to scroll through number choices. The dot under the number indicates which digit is being set = Example: [ 0 0 0 ] **Choose a number easily remembered.**
- Once the password has been set, press the ENTER button to return to the main screen.

**Once the SYSTEM SETUP has been programmed, set the PLAYBACK SETUP. Playback choices are not password protected and can be changed by the projectionist.**

### PLAYBACK SETUP (accessible by projectionist)

#### Selecting Playback Language

*This menu enables the subtitle playback language for the show. If a different language is needed for the following show, then you must change the language selection before that show begins.*

- From the main screen, press the ENTER button to access the MAIN MENU.
- Press the ▼ button and scroll to PLAYBACK MENU. Press the ► button.
- Once in PLAYBACK LANGUAGE, the available languages will display and you must enable the one you want.
- Press the ▲ ▼ buttons to scroll though the choices. Once you find one you want, press the ENTER button.
- A star will be shown next to the language once it is enabled = Example: (\*) English
- Once the playback language has been chosen, press the ENTER button to save. You may now start the show.

#### Setting Projector Power

*This menu selects if the DTS-CSP subtitle projector will be powered on or off with the DTS-CSS.*

- From the main screen, press the ENTER button to access the MAIN MENU.
- Press the ▼ button to scroll to PROJECTOR POWER. Press the ► button.
- The available power options will display and you must enable the one you want.
- Use ▲ ▼ buttons to scroll through the choices:  
 “Power On” = The DTS-CSP will power on when the DTS-CSS powers on.  
 “Power Off” = The DTS-CSP will power off when the DTS-CSS powers off
- You must enable the one you want by pressing the ENTER button. A star will be shown next to the power selection enabled = Example: (\*) Power ON
- Once the power setting has been chosen, press the ENTER button to save.

### 5.6. LOADING DTS-CSS SHOW PROGRAMS

Show programs will be delivered on DVD discs. Simply insert the “show discs”, one at a time, into the DVD drive and the information will be automatically downloaded to the hard drive. See Section 6.4 for details.

### 5.7. DTS-CSS MENUS

**From main screen, press the ENTER button to access the MAIN MENU. One choice per menu unless specified otherwise. Loader V1.00.**

#### MAIN MENU (Software V1.00.5)

- Playback Setup *Enables PLAYBACK MENU (projectionist accessible).*
- System Setup *Enables SYSTEM SETUP (should only be used by installer, may be password protected).*
- Version *Displays the system firmware version installed in the DTS-CSS.*
- Exit *Exits you back to main screen.*

#### **PLAYBACK MENU**

**This section is fully accessible to the projectionist**

- Language *Allows projectionist to select subtitle playback language.*
- Projector Power *Enables “Projector Power” menu*
- Current Lamp Hours *Enables “Current Lamp Hours” screen*
- Contents *Enables “Contents” screen*
- Clear *Enables “Clear Contents” screen*
- Exit *Exits you back to the MAIN MENU*

#### PLAYBACK LANGUAGE

- ( \* ) English *Make one choice per show.  
English horizontal subtitles*
- ( ) English & Korean *English & Korean horizontal subtitles (displayed together)*
- ( ) Korean (Vertical) *Korean vertical subtitles*
- Exit *Exits you back to PLAYBACK MENU*

Will display “unspecified” until selections made in “Available Languages” via SYSTEM SETUP

#### PROJECTOR POWER

- ( ) Power ON *Here you choose whether the DTS-CSP powers ON with the DTS-CSS -or-*
- ( ) Power OFF *powers OFF with the DTS-CSS*
- Exit *Exits you back to the PLAYBACK MENU*

#### CURRENT LAMP HOURS: ( )

*Displays current lamp hours. Lamp module must be replaced after 1400 hours of use. Press ◀ button to go back to PLAYBACK MENU.*

#### CONTENTS

*Displays enabled programs (subtitles, captions, narration)*

#0 – Narrative —————

SN 01809 Reel 1 ————— **Example** Press ▲ ▼ buttons to scroll through contents.

Burn-in test —————

#### CLEAR CONTENTS

- Quit -- Don’t clear *Choose if you want to clear programs in “contents”*
- Clear all data *Choose this if you do NOT want to clear “contents”*
- Clear all data *Choose this if you want to clear all data in “contents”*

**SYSTEM SETUP**

## → Projector Setup

- Test Mode
- TC Reader Offset
- Languages
- COM1 Configuration
- Startup Options
- Set Password
- Exit

This section may be password protected

*Enters you into the PROJECTOR MENU.*

*Enables “Test Mode” menu*

*Enables “TC Reader Offset” screen*

*Enables “Available Languages” menu*

*Enables “COM1 Configuration” menu*

*Enables “Startup Option” menu*

*Enables “Password” programming screen*

*Exits you back to MAIN MENU*

**PROJECTOR MENU**

## → Font Size

- Light Intensity
- Vert Offset-Flat
- Vert Offset-Scope
- Test Patterns
- Exit

*This menu allows you to setup the projector.*

*Enables “Font Size” menu*

*Enables “Light Intensity” menu*

*Enables “Vertical Offset” screen to adjust subtitles for flat picture format*

*Enables “Vertical Offset” screen to adjust subtitles for scope picture format*

*Enables “Test Pattern” menu*

*Exits you back to SYSTEM SETUP*

**FONT SIZE**

## → ( \* ) Normal

- ( ) Reduced 90%
- ( ) Reduced 80%
- ( ) Reduced 70%
- ( ) Reduced 60%
- Exit

*This menu allows you to choose subtitle font size.*

*Standard configuration*

*Enable this to make the subtitle text 90% smaller on-screen*

*Enable this to make the subtitle text 80% smaller on-screen*

*Enable this to make the subtitle text 70% smaller on-screen*

*Enable this to make the subtitle text 60% smaller on-screen*

*Exits you back to SYSTEM SETUP*

**LIGHT INTENSITY**

## → ( \* ) Normal

- ( ) High
- Exit

*This menu allows you to set the light intensity on the DTS-CSP.*

*Standard configuration*

*Enable this to increase the light output of the DTS-CSP*

*Exits you back to the SYSTEM SETUP*

**Set Projector**

Vertical Offset:  
[ 0 ] pixels.

*This screen allows you move the subtitle text up on-screen for the flat picture format. Scroll to desired number then press ENTER to enable and the ◀ button to return to PROJECTOR MENU. Available values are from 0 to 487*

**Set Projector**

Vertical offset for  
Cinemascope:  
[ 0 ] pixels

*This screen allows you move the subtitle text up on-screen for the scope picture format. Scroll to desired number then press ENTER to enable and the ◀ button to return to PROJECTOR MENU. Available values are from 0 to 487.*

**TEST PATTERN**

## → ( ) BLACK

- ( ) Flat Mask
- ( ) Scope Mask
- ( ) View Area
- ( ) White
- ( ) Full Screen
- ( ) Gray Pattern (1)
- ( ) Gray Pattern (2)
- ( ) Gray Pattern (3)
- ( ) Gray Pattern (4)
- Exit

*This menu enables test patterns*

*No pattern or light, opens DTS-EMA douser*

*White box in subtitle area in “flat” picture format*

*White box in subtitle area in “scope” picture format*

*White light on-screen with checkerboard test grid in subtitle area*

*White light only on full screen*

*Checkerboard test grid on full screen*

*Gray bar test, dark to white, on full screen*

*Gray test grid, dark to light, on full screen*

*Gray bar, with black horizontal lines, test on full screen*

*Gray test grid, with black horizontal lines, on full screen*

*Exits you back to PROJECTOR MENU and closes DTS-EMA douser*

TEST MODE MENU

- Self-Play
- Test Output
- Test Inputs
- Exit

*This menu enables the test mode*  
*Enables "Self Play" menu*  
*Enables "Test Menu"*  
*Enables "Test Inputs" screen*  
*Exits you back to PROJECTOR MENU*

SELF PLAY MENU

- ( ) Buzz And Bill
- ( ) 1K @ -20 dB FS
- ( ) 1K @ -1dB FS
- ( ) 1KHz @ Full Scale
- ( ) Pink Noise
- Exit

*This menu enables self play tests*  
*Enables Buzz and Bill narration, subtitles, and captions*  
*Enables the **standard** test tone, 1kH -20 dB FS, checking the AUDIO OUT level*  
*Special test tone*  
*Special test tone*  
*Special test*  
*Exits you back to TEST MODE MENU*

TEST MENU

- TITLES LED ON
- AUDIO LED ON
- AUX LED ON
- TIMECODE LED ON
- SYSTEM LED ON
- LAMP LED ON
- FORMAT 0
- FORMAT 1
- FORMAT 2
- FORMAT 3
- FORMAT 4
- FORMAT 5
- FORMAT 6
- FORMAT 7
- AUTO 0
- AUTO 1
- AUTO 2
- AUTO 3
- TC READER LED
- Exit

*This gives enables specific tests, given below:*  
*Lights the TITLES LED*  
*Lights the AUDIO LED*  
*Lights the AUX LED*  
*Lights the TIMECODE LED*  
*Lights the SYSTEM LED*  
*Lights the LAMP LED*  
*Engages FORMAT 0 closure*  
*Engages FORMAT 1 closure*  
*Engages FORMAT 2 closure*  
*Engages FORMAT 3 closure*  
*Engages FORMAT 4 closure*  
*Engages FORMAT 5 closure*  
*Engages FORMAT 6 closure*  
*Engages FORMAT 7 closure*  
*Engages AUTO 0 closure*  
*Engages AUTO 1 closure*  
*Engages AUTO 2 closure*  
*Engages AUTO 3 closure*  
*Lights timecode reader's LED*  
*Exits you back to TEST MODE MENU*

AUTOMATION CONNECTOR  
(future)

TEST INPUTS

Format    Auto  
 -----    \*-----

(future)

Set Timecode Reader

Offset:  
 [ 24.25 } frames

*This screen allows you program in the DTS-CSS OFFSET*  
*Press ENTER to save and ◀ button to go back to SYSTEM SETUP*  
*Available values are from 0 to 100 in increments of 0.25 frames.*

AVAILABLE LANGUAGES

- [ \* ] English
- [ ] English Captions
- [ \* ] English & Korean
- [ ] French
- [ ] Japanese
- [ \* ] Korean (Vertical)
- [ ] Korean (Horizont
- Exit

*This menu enables language selections in PLAYBACK LANGUAGE*  
*English horizontal subtitles*  
*English captions*  
*English & Korean horizontal subtitles (displayed together)*  
*French horizontal subtitles*  
*Japanese horizontal subtitles*  
*Korean vertical subtitles*  
*Korean horizontal subtitles*  
*Exits you back to SYSTEM SETUP*

Choose as many as required and to appear in PLAYBACK LANGUAGE

COM1 CONFIGURATION

- ( ) Subtitle Project
- ( ) Rear Window
- Exit

*This menu sets the function for COM1, choose one.*

*Choose this if using the DTS-CSP*

*Choose this for Captions Option using the Rear Window system.*

*Exits you back to SYSTEM SETUP*

STARTUP OPTION

- ( \* ) Fast Startup
- ( ) Network Enabled
- Exit

*This menu sets if unit to be programmed locally or via network*

**Standard**, *choose this if setting unit locally*

*Choose this of setting unit via network (future)*

*Exits you back to SYSTEM SETUP*

PASSWORD:

[ 0 0 0 ]  
\*

*This screen allows you to set the  
SYSTEM SETUP password. Star under  
number indicates digit being set.*

DTS-CSS V1.00.5 Copyright © 2001 By Digital Theater Systems, Inc.
---

## 5.8. DTS-CSS SYSTEM TEST

**Equipment Required: “BUZZ AND BILL SHOW” DTS Demo Film. If a DTS player is in the system, you will also need the “BUZZ AND BILL SHOW” Disc.**

1. Power on the DTS-CSS system (including all options).

### *Load Show Program and Reboot DTS Players*

2. If a DTS player is in the system, load the “BUZZ AND BILL SHOW” disc into the player.
  - Verify the unit fully boots, indicated when the SYSTEM light blinks.
  - NOTE: The SYSTEM light will blink **ONLY** when show/test discs are loaded into the DTS player.
3. Load DTS test disc into DTS-CSS unit and thread the “BUZZ AND BILL SHOW” film.
  - Once the test disc program is loaded, verify the disc ejects itself from the DTS-CSS unit.
  - Verify the DTS-CSS SYSTEM light blinks.

### *Check TIMECODE and Sync*

4. Start the film and verify the TIMECODE light on the DTS-CSS unit brightens. The light should illuminate steadily and not blink.
5. If a DTS player is in the system, verify its TIMECODE light illuminates bright and steady. Its SYSTEM light should be blinking. The cinema processor should have automatically pulsed to a digital format and the digital soundtrack should be heard in the auditorium.

### *Performance Test*

6. If a DTS player is used, while the test film is playing, go into the auditorium and verify the DTS 6-track digital sound is in sync with the picture projected.
7. If a DTS player is not used, play the test film in the SR format. NOTE: The “BUZZ AND BILL SHOW” film’s analog track was recorded in SR, if your cinema processor does not have SR capability, play it in A-Type.
8. If the DTS-CSP subtitle projector is used, while the test film is playing, verify correct subtitles are projected onto the screen in sync with the dialogue track. Verify the subtitles are easy to read and are correctly located on the screen.
9. If captions are used, while the test film is playing, verify correct captions are displayed in sync with the dialogue track.
10. If narration is used, while the test film is playing, verify the correct narration track is heard clearly through the headsets and that the descriptive narration is in sync with the action on-screen. Normally, the narration track will not be heard while on-screen dialogue is playing in the auditorium.
11. After the test film has stopped playing
  - Verify the DTS-CSP subtitle projector mask douser closes when subtitles are not projected.
  - Verify no sound output on the narration headsets.
  - Verify the caption screen is blank.
  - Verify the DTS player automatically pulsed the cinema processor to the NONSYNC format.

## SECTION 6 USER SYSTEM OPERATION

### 6.1. How Do I Prepare For A Show?

- Power on the DTS-CSS and all optional equipment used in your system (DTS player, subtitle projector, narration transmitter, caption display).
- Verify the programs you wish to run are enabled in the DTS-CSS “Playback-Language” Menu.
  - ① Start from the Main Screen and press ENTER for MAIN MENU.
  - ② Press ► button to select “Playback Setup” and enter the PLAYBACK MENU.
  - ③ Press ► button to select “Language” and enter PLAYBACK LANGUAGE.
  - ④ Press the ▼ button to view the show selection. A star will next to the show will indicate the choice = Example: ( \* ) English If not correct for your show, see Step 6.4 to change selection.
  - ⑤ Once verified, press the ▼ button and scroll to EXIT. Press the ENTER button to return to the Main Screen.
- If using a DTS player, verify the correct movie discs are loaded.
- Thread the film through the DTS reader (if used) and the film projector.
- Verify the subtitle projector’s (if used) lens cap is removed.
- Verify the DTS-CSS and DTS player (if used) are booted up (all SYSTEM lights should be blinking).
- Start the film and verify the DTS equipment is playing.
- Verify operation of optional equipment (if used)

### 6.2. How Do I Power On/Off the DTS-CSS?

- Power on the DTS-CSS by pressing the front panel toggle switch to the “on” position.
- The rear panel supply switch must *always* be set to “1”.

### 6.3. How Do I Install DTS-CSS Show Programs into the DTS-CSS?

Shows will be delivered on DTS-CSS “Show Discs”. These discs must be loaded, one at a time, into the DTS-CSS unit. The “show disc” is placed in the DTS-CSS DVD drive and downloaded into the DTS-CSS hard drive. All shows are played off the hard drive.

#### **How To Download Shows Into The DTS-CSS**

- ① Power on the DTS-CSS and press button on DVD drive to eject the tray.
- ② Once tray opens, place “show disc” on tray and press drive button to close tray.
- ③ The DTS-CSS unit will automatically download the shows on the disc to the hard drive.
- ④ Once the download is complete, the drive tray will open.
- ⑤ Remove disc and close empty tray.
- ⑥ Verify the DTS-CSS SYSTEM light is blinking.

#### 6.4. How Do I Select Show Programs on the DTS-CSS?

- Load the “CSS-Show” disc into the DVD drive. Allow time for the hard drive to download the information off the disc. The display will tell you when it is downloading the disc.
- Once the download is complete, the disc will be ejected. Remove that disc and load in the next if more than one disc is needed for the show. Repeat until all “CSS Show” discs are downloaded.
- Verify programs have downloaded onto the hard drive.

##### **How to choose subtitle language**

- ① Start from the Main Screen and press ENTER for MAIN MENU.
- ② Press ► button to select “Playback Setup” and enter the PLAYBACK MENU.
- ③ Press ► button to select “Language” and enter PLAYBACK LANGUAGE.
- ④ Press the ▼ button to scroll through choices. Once you see the language needed, press the ENTER button. A star should appear next to the selection = Example: ( \* ) English.
- ⑤ After making your selection, press the ▼ button and scroll to EXIT. Press the ENTER button to save and return to the Main Screen.

#### 6.5. How Do I Know When the DTS-CSS System is Operating Correctly?

- Once film is played, the TIMECODE and PLAY lights should illuminate and SYSTEM light continue to blink on the DTS-CSS and DTS player.
- The serial number of the DTS-CSS programs and DTS player’s movie discs must match the film’s serial number embedded in timecode, or they will not play.
- OFFSET must be properly set for DTS-CSS programs and options to play in sync with action on-screen.

#### 6.6. What Regular Maintenance is Required on the DTS-CSS System?

- Use compressed air to blow off the reader’s optics after each show.
- Using a DVD cleaning disc, the DVD drive should be cleaned once a week.
- **The DTS-CSP subtitle projector lamp must be changed after 1400 hours of use. *Failing to change the lamp after 1400 of in-use hours may result in damage to the DTS-CSP and is not covered by warranty.***

You will be warned when 1400 of in-use hours has been reached by:

- ① The DTS-CSS LAMP light will glow and
- ② During boot-up, the DTS-CSS will display a reminder

#### 6.7. How Do I Replace The Lamp On The DTS-CSP, Subtitle Projector?

- See Section 7.4.2.



## SECTION 7 MAINTAINANCE AND TROUBLESHOOTING

### 7.1. UPGRADING DTS-CSS SYSTEM SOFTWARE

Occasionally, new system (operating) software will be sent on a disc. Simply insert the disc into the DVD drive and the information on it will be automatically uploaded to the hard drive. Generally, software updates will be included on “show” discs and download automatically.

### 7.2. LOADING DTS-CSS SHOW PROGRAMS

Show programs will be delivered on DVD discs. Simply insert the discs, one at a time, into the DVD drive and the show will be automatically uploaded to the hard drive. See Section 6.4 for details.

### 7.3. DTS-CSS SYSTEM MAINTAINANCE

- Use compressed air to blow off the DTS Reader’s optics after each show.
- The DVD drive should be cleaned once a week using a DVD cleaning disc.

### 7.4. DTS-CSP, SUBTITLE PROJECTOR MAINTAINANCE

**Subtitle Projector Lamp Module Maintenance** (after every 100 hours of use)

**CAUTION:** All cleaning and lamp module inspections must occur when the lamp is cool to avoid personal injury.

- 1) Vent screens on the module must be inspected. Any accumulated material (lint, dust, smoke residue, etc.) must be carefully removed with a gentle vacuum cleaner or canned air and a soft brush.  
**NOTE:** If a large accumulation is seen, the inspection interval time should be decreased with the objective of maintaining clean screens and vents.
- 2) The lamp bulb must be inspected for bulging, white cloudy appearance; blackened bulb and bulbs with separated ceramic collars must be replaced.
- 3) **The lamp module must be replaced after 1400 hours of use.**

**WARNING:** The lamp module must NOT be modified in any way. If the cover glass is missing, removed or damaged, the unit will be damaged by excessive heat and will void warranty. Blocked or damaged lamp module screens can reduce lamp life or increase the possibility of rupture containment failure.

#### 7.4.1. Adequate Air Space (as needed / during operation)

- Air space around the unit must be maintained.
- ◆ Minimum clearances are 6" (15.24 cm) either side
  - ◆ Flush with the mask front wall in front, 0" in back
  - ◆ Minimum 12" (30.48 cm) above and below

**NOTE:** All projector vents and the external blower must not be obstructed in any way.

#### 7.4.2. Maintaining The Lens (as needed)

The projection lens should be inspected regularly and cleaned by the approved cleaning method (soft non-abrasive cloth and mild glass cleaner). If the projector will not used for a long period, cover lens with lens cap.

### 7.4.3. Procedure for Cleaning the Lens

1. Apply a non-abrasive camera lens cleaner to a soft, dry cloth.
  - Avoid using excess amount of cleaner, and don't apply cleaner directly to the lens.
  - Abrasive cleaners, solvents or other harsh chemicals might scratch the lens.
2. Lightly wipe the cleaning cloth over the lens in a circular motion.
3. Verify the focus and zoom adjustments after cleaning is finished.

### 7.4.4. Procedure for Replacing the Lamp Module

 **WARNING:** To avoid burns, allow the projector to cool for at least 30 minutes before you open the lamp module door. Never extract the lamp module while the projector is operating.

The lamp hour counter in the Status menu counts the number of hours the lamp is in use. Change the lamp when the brightness is no longer acceptable or after 1400 hours. **The lamp must be changed at 1400 hours and the lamp hour counter must be reset every time the lamp module is changed.** Contact DTS to order a new lamp module. See “Replacement Parts List” in this section.

**Tool Required:** ¼” (0.5 cm) flat bladed screwdriver

1. Turn off the projector and unplug the power cord.
2. Wait 30 minutes to allow the projector to cool thoroughly.

**WARNING !!**  
DO NOT LOOK  
DIRECTLY INTO  
THE LIGHT

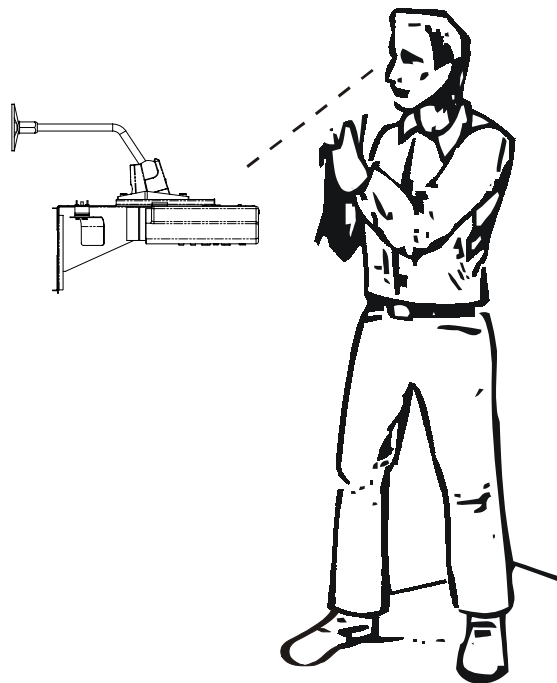

3. Push the ridge on the lamp door toward the back (see figure below). The arrow on the lamp door should point to the unlock icon on the bottom of the projector. Lift the door up.

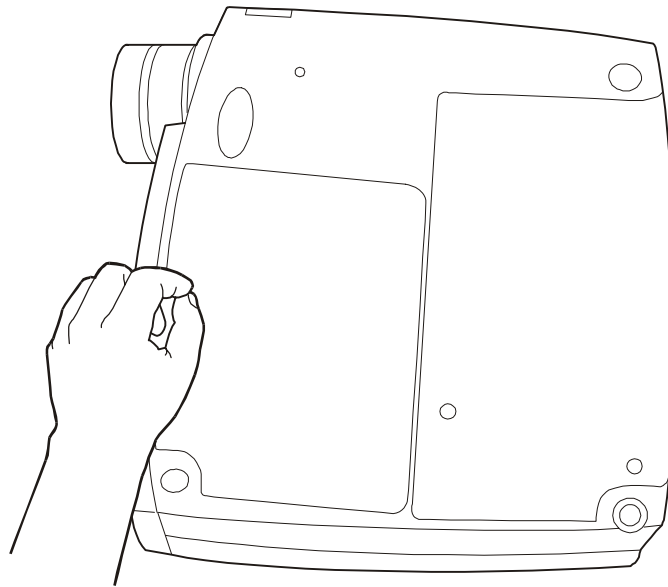

**CAUTION:** Never operate the projector when the lamp door is open or removed. This disrupts the airflow and causes projector to overheat.

4. Loosen the two captive screws on the outside of the module. See figure below.

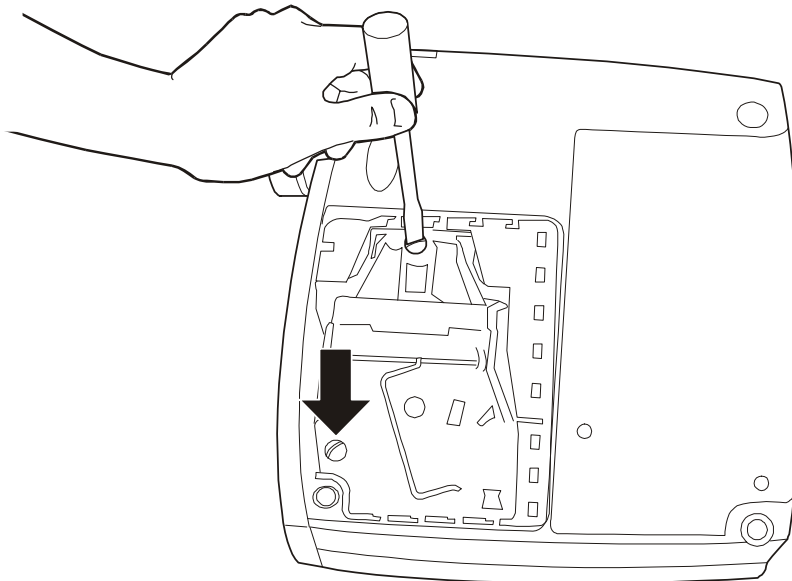

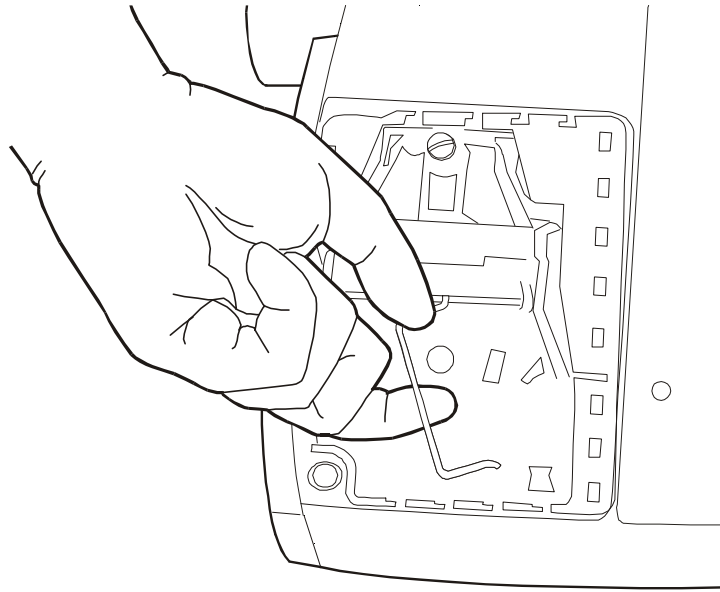

5. Lift and grasp the metal bail wire and lift the module out (see figure below). Dispose of the lamp module in an environmentally proper manner.

 **WARNING:** Be extremely careful when removing the lamp module. In the unlikely event that the bulb ruptures, small glass fragments may be generated. The lamp module is designed to contain these fragments, but use caution when removing the lamp module.





6. Install the new lamp module, being sure to align the connector properly.

 **WARNING:** Do not drop the lamp module or touch the glass bulb! The glass may shatter and cause injury.

7. Push the module in until it is flush with the bottom case of the projector.
8. Tighten the screws on the outside of the module.
9. Replace the lamp door by inserting the hooks on the lamp door into the slots on the projector and pressing the lamp door into place. The arrow on the lamp door should point to the lock icon on the bottom of the projector. If the lamp door does not fit properly or bulges out, remove the door and reseat the lamp module.
10. Plug in the power cord and press the green “POWER”  button to turn the projector back on.

**11. You must reset the lamp hour counter on the projector.**

- ① Press and hold the “MENU”  button until the LED flashes.
- ② While LED flashes, press and hold “SOURCE”  and “VOLUME -“  buttons. Hold for 5 seconds. This will reset the counter.

*Projector shown upside down (mandatory installation position)*

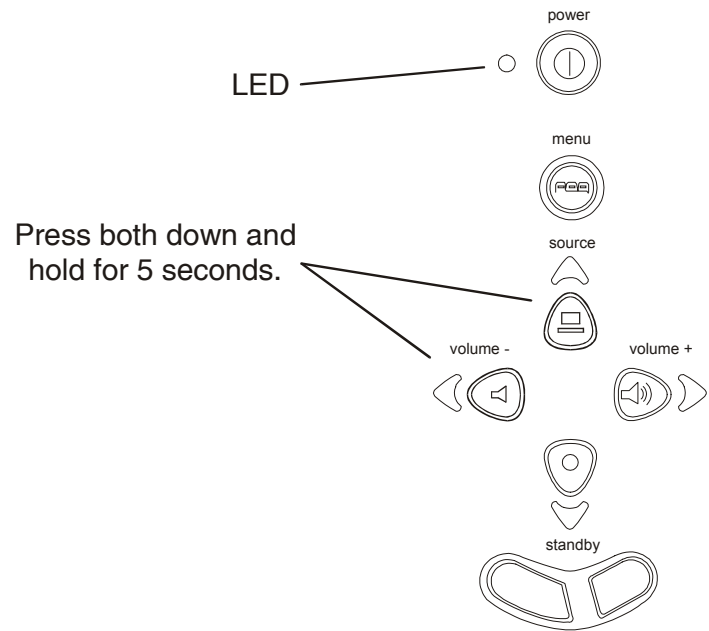
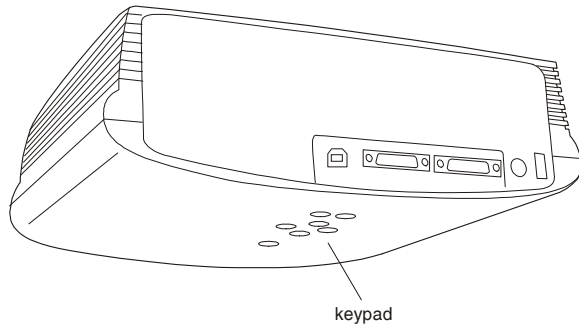
**12. Verify the projector's lamp counter was reset by viewing the lamp counter in the DTS-CSS menu.**

- Press ENTER button to enter MAIN MENU.
- Press the ▼ button and scroll PLAYBACK SETUP. Press the ► button
- Once in PLAYBACK SETUP, press ▼ button and scroll to CURRENT LAMP HOURS.
- Press the ► button. You should see that the lamp hour counter is at “0”.
- If the counter not at “0”, repeat Step 11. You will need to exit then re-enter this menu to see the change.
- Press ENTER button to exit to main screen.

## 7.5. TROUBLESHOOTING THE DTS-CSS SYSTEM

### No subtitles

- Verify the DTS-CSS SYSTEM light is blinking.
- In DTS-CSS MENU, verify SYSTEM SETUP configuration is set to “Projector”.
- In DTS-CSS MENU, verify the subtitle show is loaded on the hard drive and is enabled.
- When film is playing, verify the DTS-CSS TIMECODE light is illuminated steady on and TITLES light is on.
- Verify the subtitle projector is powered on.
- Verify cabling is securely connecting the DTS-CSS to the DTS-EMA and DTS-CSP. Check all 3 cables for broken wires.
- Go into the PROJECTOR Menu and verify the number of lamp hours has not exceeded 1400.  
*The DTS-CSP lamp must be replaced after 1400 hours of use.*
- Is the LAMP light blinking on the DTS-CSS? If yes, the DTS-CSP lamp is burned out and must be replaced.
- Verify the DTS-EMA fan is rotating. The fan cools the DTS-CSP, and if it over-heats, it will turn itself off. If the fan is not rotating, replace it.
- During intermission, enable the DTS-CSS self-play test “Buzz And Bill” and watch for subtitles. While test is playing, verify the function of the DTS-EMA dower. It should open when it gets the command to open - which is when subtitles are playing. If it will not open, check the condition of the solenoid on the DTS-EMA.

### Subtitle text is distorted on-screen

- Clean the lens on the DTS-CSP subtitle projector.
- If the image is fuzzy, recheck the DTS-CSP subtitle projector focus adjustment.
- Verify the PROJECTOR VIDEO cable was purchased from DTS. *DO NOT MAKE YOUR OWN VIDEO CABLE.* The cable requires special shielding and ferrite protection.

### Subtitle text is dim on-screen

- Verify the DTS-EMA fan is rotating. If fan stops, the DTS-CSP light will dim. If fan stops rotating, replace it.
- If fan okay and text needs brightening, go into DTS-CSS PROJECTOR Menu, try switching the power to “high”.
- Go into the PROJECTOR Menu and verify the number of lamp hours has not exceeded 1400.  
*The DTS-CSP lamp must be replaced after 1400 hours of use.*

### Subtitle text is not the correct size on-screen

Go into the “projector-font size” menu and select the appropriate font size. A higher number will make the print bigger and a smaller number will make the print smaller.

### Wrong subtitles are playing

- In DTS-CSS MENU, verify the show language is loaded in memory.
- In DTS-CSS MENU, verify SYSTEM SETUP → LANGUAGES is enabled to the language you want.
- Verify the DTS-CSS OFFSET value is correctly set.

### The DTS-CSS LAMP light constantly blinks or is always illuminated on

- Go into the PROJECTOR Menu and verify the number of lamp hours has not exceeded 1400.  
*The DTS-CSP lamp must be replaced after 1400 hours of use.*
- The DTS-CSS will turn off the DTS-CSP lamp after 1400 of in-use hours. To avoid damage to the subtitle projector, you must replace its lamp.

### I’ve just replaced the DTS-CSP lamp but it will not light

- Go into the PROJECTOR Menu and verify that the lamp counter has been reset to “0”. If it has not, go to Section 7.4.4, Step 11 and reset the counter.
- Verify the DTS-CSP is powered on.
- Verify cabling is securely connecting the DTS-CSS to the DTS-EMA and DTS-CSP. Check all 3 cables for broken wires.
- Verify the DTS-EMA fan is turning. The fan cools the DTS-CSP. If the fan is not rotating, replace it with DTS part number 9002 E469 00.

**Light is leaking out around the subtitles on-screen**

Reset the position of the magnetic trims on the DTS-EMA mask assembly. Use the test patterns in DTS-CSS PROJECTOR Menu.

**Light is seen in subtitle area when no subtitles are supposed to play**

- The DTS-EMA douser is probably open. Be sure “Douser/Fan Control” cable is plugged in and DTS-EMA fan is turning. Check cable for broken wires
- Verify the DTS-CSS TEST PATTERNS has been correctly exited. All TEST PATTERNS (Projector Menu) should be turned off.
- Power off DTS-CSP subtitle projector until there is time to troubleshoot. DTS-EMA solenoid could be bad

**Subtitles are cut off on the screen**

- Verify the positioning of the DTS-CSP.
- Verify the positioning of the DTS-EMA magnetic trims. Use the test patterns in DTS-CSS PROJECTOR Menu.

**No captions**

- In DTS-CSS MENU, verify SYSTEM SETUP → CONFIGURATION is function is set to “Captions”.
- In DTS-CSS MENU, verify the captions for the show is loaded on the hard drive and is enabled.
- Verify the caption equipment is powered on.
- Verify the DTS-CSS TIMECODE light is illuminated steady on.
- Verify the DTS-CSS AUX light is illuminated.
- Verify COM 1 cable is securely connecting the DTS-CSS to the caption system. Check cable for broken wires.
- Refer to the caption playback equipment manufacturer for test procedure.

**No narration**

- Verify the narration transmitter is powered on.
- Verify the narration headsets are connected and their volume is turned up.
- In DTS-CSS MENU, verify the narration show is loaded on the hard drive and is enabled.
- Verify the DTS-CSS TIMECODE light is illuminated steady on.
- Verify the DTS-CSS AUDIO light is illuminated.
- Enable DTS-CSS self-play test “1K @ -20dB FS”. Verify 117 mV RMS ( $\pm 10$ mv) output at AUDIO OUT  
If no output, replace the E303 board. If there is output, refer to the transmitter manufacturer for test procedure.

**Narration sounds too loud/soft**

*Remember volume controls are usually on each individual headset*

- Enable DTS-CSS self-play test “1K @ -20dB FS”. Verify 117mV RMS ( $\pm 10$ mv) output at AUDIO OUT  
If no output, replace the E303 board. If there is output, refer to the transmitter manufacturer for test procedure.

**Narration sounds distorted**

- Enable DTS-CSS self-play test “1K @ -20dB FS”. Verify 117 mV RMS ( $\pm 10$ mv) output at AUDIO OUT
- Enable the DTS-CSS self-play test “Buzz And Bill” and listen with the narration headsets.
- Try replacing the internal E303 board.
- Refer to the transmitter manufacturer for test procedure.

**Noise in narration track**

- Verify the AUDIO OUT cables are not routed next to power lines, film projector motors, or florescent lights.
- If getting RF interference, contact DTS for ferrite bead suppressors that attach to the audio output cables.

**The DTS-CSS is NOT playing in sync with the sound track or action on-screen**

Go into the DTS-CSS Menu and verify the OFFSET value has been correctly set. See Section 5.2. “OFFSET.”  
If you have a DTS player, then verify the offset value set in that unit matches what is set on the DTS-CSS.

**Forgot Password**

- Contact DTS.

*DTS-EMA assembly drawing*

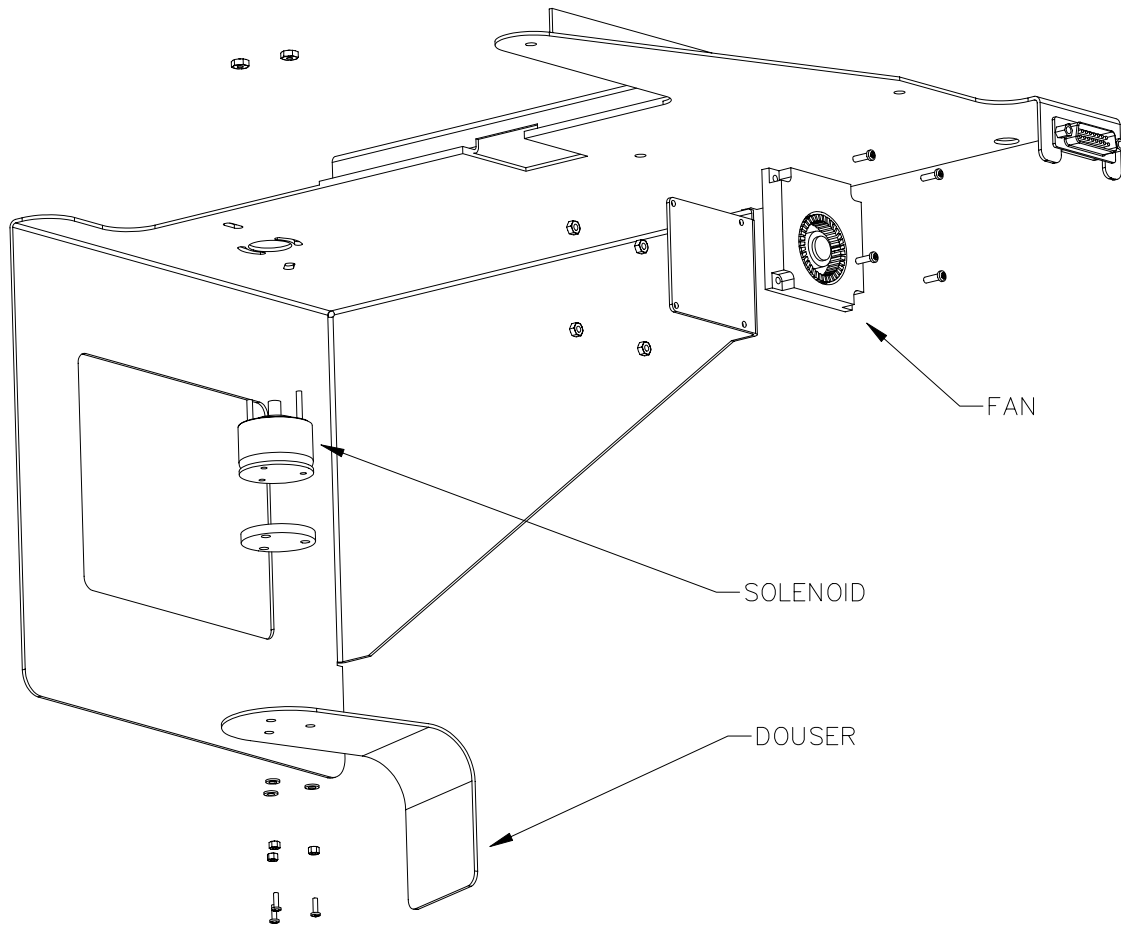

If the fan or douser requires replacement, order DTS P/N 9002 E469 00, fan/solenoid subassembly. This will include wiring for easy part replacement. Fan and solenoid not sold separately.

Replacement mask trims are available. Please specify size and refer to Section 7.8 for part numbers.



# DTS 35mm TRACK SPECIFICATION

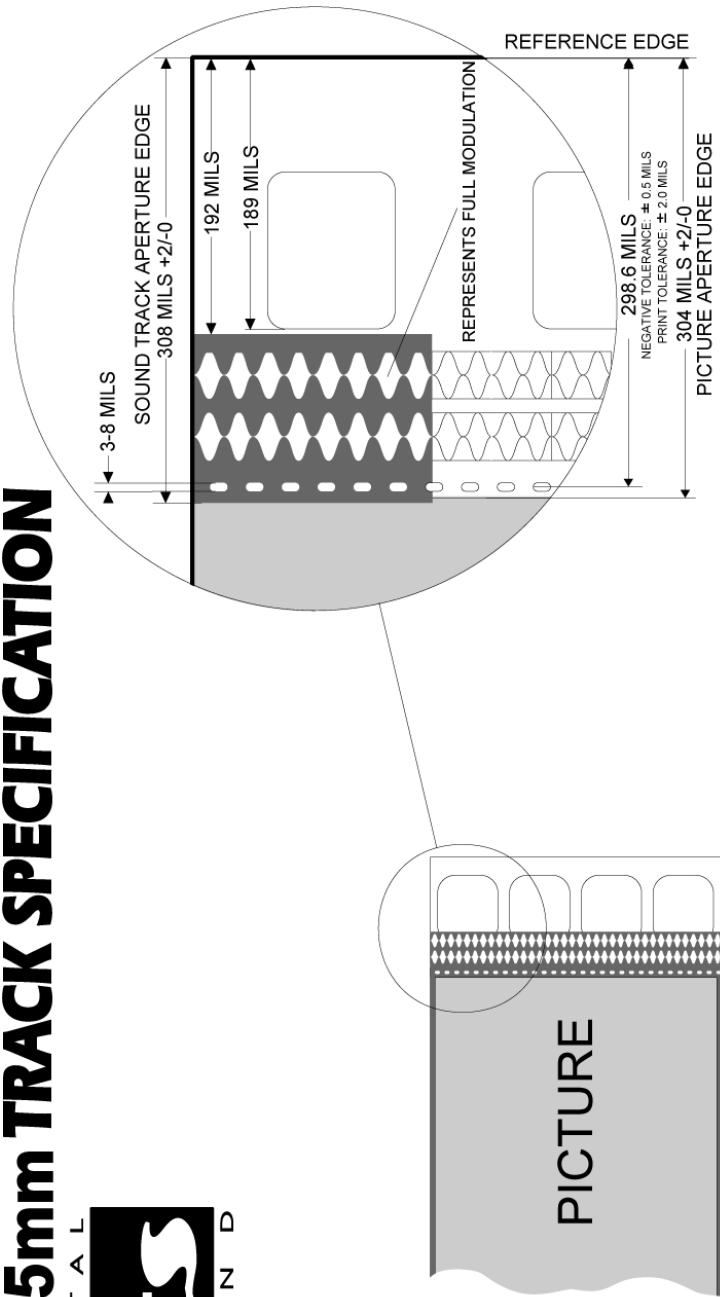
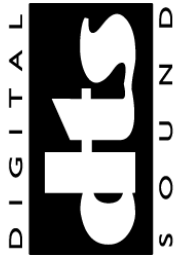

Ref: ANSI/SMPTE 40-1991, 111-1996  
 NOTE: Application to 304 mils  $+2/-0$   
 as per reference above

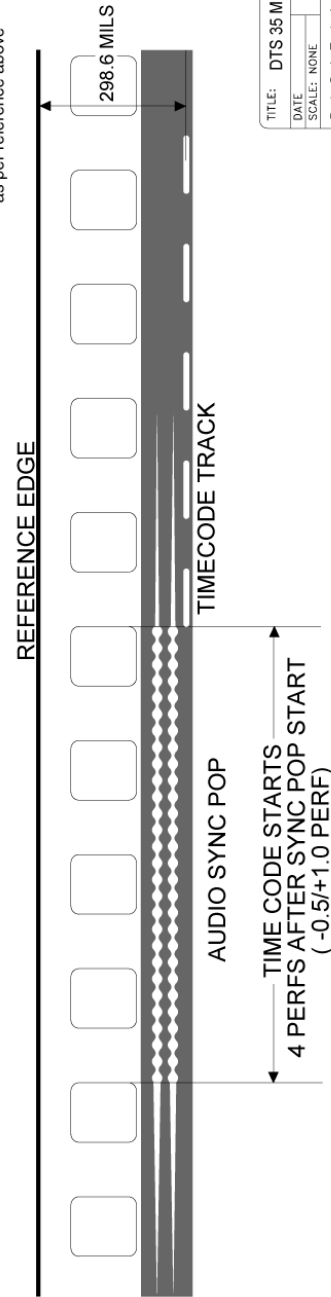

TITLE: DTS 35 MM TRACK SPECIFICATION		DATE: _____	APPROVED: _____	DRAWN: J. BELLARIA
SCALE: NONE		REV. A		
DIGITAL THEATER SYSTEMS 5171 CLARETON DR. AGOURA HILLS, CA 91301				
FILE NAME	TIE243A (FILMSPEC).AI	DWG. NO.	TIE-243A	

PH: 818-706-3525 Fax: 818-706-1868  
 Revised: February 16, 2000

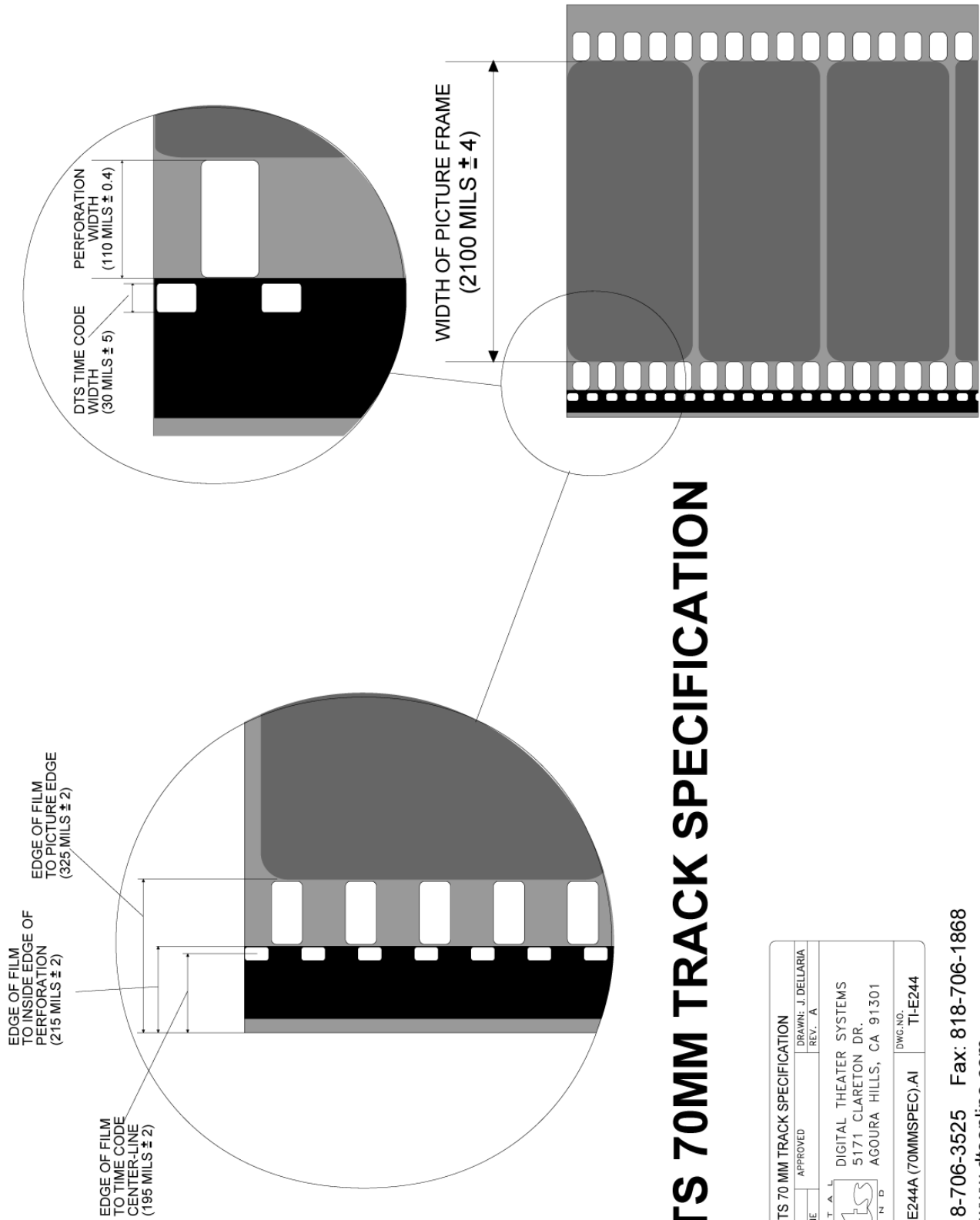

# DTS 70MM TRACK SPECIFICATION

TITLE: DTS 70 MM TRACK SPECIFICATION		DRAWN: J. DELLARIA	
DATE	APPROVED	REV. A	
SCALE: NONE	DIGITAL THEATER SYSTEMS 5171 CLARETON DR. AGOURA HILLS, CA 91301		
FILE NAME: TIE244A (70MMSPEC).AI		DWG. NO.: TI-E244	

PH: 818-706-3525 Fax: 818-706-1868  
 Web: www.dtsonline.com

**7.6. DTS TECHNICAL SUPPORT**

USA, California Telephone: (818) 706-3525  
 (800) 959-4109 (toll free continental USA only)

USA, California Fax: (818) 706-1868

DTS engineers are available to assist you. If any emergency occurs after business hours, please leave a message with the answering service. Your call will be returned as soon as possible.

UK, England Telephone: 44-1189-349199

UK, England Fax: 44-1189-349198

INTERNET users may email DTS Cinema Technical Support at: [cinematech@dtsonline.com](mailto:cinematech@dtsonline.com)

DTS web site: <http://www.dtsonline.com>

**7.6.1. DTS SYSTEM TEST MATERIALS**

E107	DTS Technician's Kit (includes test disc & 35mm film, setup disc, DTS shirt, & tweaker)
6060 0007 00B	6-Track Setup Disc, DS3 (for testing DTS players, not the DTS-CSS)
6060 0003 00	BUZZ AND BILL SHOW Test Disc (used with test film)
6800 0001 00	DTS Test Film, 35mm, BUZZ AND BILL SHOW (includes 35mm offset measurement)
6800 0002 00	DTS 70mm Offset Measurement Film

**7.7. DTS-CSS SYSTEM REPLACEMENT PARTS LIST**

	<u>DTS-CSS Unit</u>
5102 0008 00	DVD Drive, 12x IDE
5103 0005 00	Hard Drive, 20GB EIDE
9030 E303 00	E303, Audio & Timecode Board Assembly
9030 E221 00	E221, Display Board Assembly
9030 E430 00	E430, EMA Interface Board Assembly
9022 E460 00	E460, Interconnect Cable ( <i>connects E430-J2 to E303-J3</i> )
9022 E459 00	E459, Interconnect Cable ( <i>connect E303-P2 to E221-J5</i> )
1902 0006 00	Power Switch ( <i>front panel</i> )
2201 SWOD 09	Power Supply ( <i>includes rear panel switch and cooling fan</i> )

	<u>DTS-CSP, Subtitle Projector</u>
1802 0001 00	Lamp Module

	<u>DTS-EMA, External Mask</u>
9002 E469 00	Fan/solenoid Subassembly ( <i>fan and solenoid not sold separately</i> )
9020 E472 02	Large Magnetic Trim for mask, 3.16" x 6.7"
9020 E472 01	Medium Magnetic Trim for mask, 1.96" x 6.7"
9020 E472 00	Small Magnetic Trim for mask, 1.17" x 6.7"

NOTE: Part numbers are subject to change.

**7.8. DTS-CSS SYSTEM PARTS LIST**

DTS-CSP	Subtitle Projector, throw up to 50 feet (15.24 meters)
DTS-CSPL1	Subtitle Projector, throw up to 120 feet (36.6 meters)
DTS-EMA	External Mask Assembly for DTS-CSP subtitle projector <i>(includes magnetic trims)</i>
1010 0037 00	Mount for DTS-CSP subtitle projector, to ceiling/wall, 14" (35.56 cm) long <i>(mounting fasteners to wall/ceiling not supplied by DTS)</i>
D600-00	DTS Timecode Reader Head, 35mm
E108	Auxiliary Roller, 35mm
D600-02	DTS Timecode Reader Head, 70mm
E163	Auxiliary Roller, 70mm

Mounting brackets for reader (hardware included), permanent 35mm or 70mm)

D614	Standard bracket <i>(for Century, Simplex, Ballantyne projectors)</i>
D616	Phillips AA bracket <i>(for Norelco projector)</i>
D617	"L" bracket <i>(for Kinoton projector)</i>
D622	Front mount bracket <i>(use with Dolby SR-D™ or Sony SDDS™ readers)</i>
5006 0001 00	Cinemeccanica bracket <i>(use with D614 standard bracket)</i>
9003 E102 00	70mm spacer kit <i>(used to fit a 35mm reader in a 70mm space)</i>

Mounting brackets for reader (hardware included), switchable 35mm / 70mm)

D615	Universal bracket
D625	35mm/70mm standard bracket used with breakaway plates
D628	Adapter panel for D617 "L" bracket <i>(so breakaway plates can be used)</i>
D626	Breakaway <i>(spacing block)</i> plates for 35mm DTS reader head
D627	Breakaway <i>(spacing block)</i> plates for 70mm DTS reader head

System Cables (see Section 4.9, system wiring diagrams, for details of what is required for individual systems)

9022 D435 01	Timecode Cable, 30 feet long <i>(standard, other lengths available)</i>
9022 D435 21	Timecode "Y" Cable, 30ft/30ft <i>(for dual projectors) (standard, other lengths available)</i>
9022 F120 00	Timecode "Y" Cable Adapter
9022 E312 00	Dual Projector Timecode Adapter Cable <i>(for DTS-6AD with dual projectors)</i>
2503 0028 00A	SVGA, Video Cable, 25 feet long <i>(standard)</i>
2503 0028 01A	SVGA, Video Cable, 50 feet long
9022 E435 00A	Control Cable, 25 feet long <i>(standard)</i>
9022 E435 01A	Control Cable, 50 feet long
9022 E440 00A	Null Modem Cable, 25 feet long <i>(standard)</i>
9022 E440-01A	Null Modem Cable, 50 feet long
2503 0020 00	Mono audio cable, RCA jack both ends, 6 feet long <i>(standard)</i>
2503 0011 00	Mono audio cable, RCA jack both ends, 10 feet long
2501 0001 00	Power Cable, detachable, 6 feet long with plug <i>(standard)</i>
9003 E119 00	Standard rack mount screw kit <i>(for DTS-CSS unit or DTS players)</i>

NOTE: Part numbers are subject to change.

**SECTION 8**

**APPENDICES**

Appendix A

Cleaning the DTS-CSP Lamp Filter Screen

## Maintenance to Prevent Premature DTS-CSP Lamp Failure

In dirty or dusty environments, the lamp module dust filter screen in the DTS-CSP projector can become plugged, causing excessively high temperatures inside the lamp module. Excessively high temperatures can cause premature lamp failure. Routine maintenance to remove dust and dirt from the filter screens lowers the lamp operating temperature and lengthens lamp life. As depicted below, clean the lamp module dust filter screen every **200-250 hours** when the projector is used in areas with high levels of airborne contaminants like lint, dust or smoke.

### Procedure for cleaning the lamp module dust filter screen

1. First, be sure the projector is cool. Then, remove the lamp door and lamp module.



2. After removing the lamp module, examine the condition of the dust filter screen. The screen is in the front part of the lamp module. Dirt and dust accumulation on the screen must be removed.



3. Use a cotton swab dipped in isopropyl alcohol to lightly wipe the screen. After you've wiped the screen, use canned air to blow away remaining contaminants.



4. Before replacing the cleaned lamp module, use canned air to clean out the projector lamp house cavity. Then, replace the lamp and lamp door.

