

FILM-TECH

THE INFORMATION CONTAINED IN THIS ADOBE ACROBAT PDF FILE IS PROVIDED AT YOUR OWN RISK AND GOOD JUDGMENT.

THESE MANUALS ARE DESIGNED TO FACILITATE THE EXCHANGE OF INFORMATION RELATED TO CINEMA PROJECTION AND FILM HANDLING, WITH NO WARRANTIES NOR OBLIGATIONS FROM THE AUTHORS, FOR QUALIFIED FIELD SERVICE ENGINEERS.

IF YOU ARE NOT A QUALIFIED TECHNICIAN, PLEASE MAKE NO ADJUSTMENTS TO ANYTHING YOU MAY READ ABOUT IN THESE ADOBE MANUAL DOWNLOADS.

WWW.FILM-TECH.COM

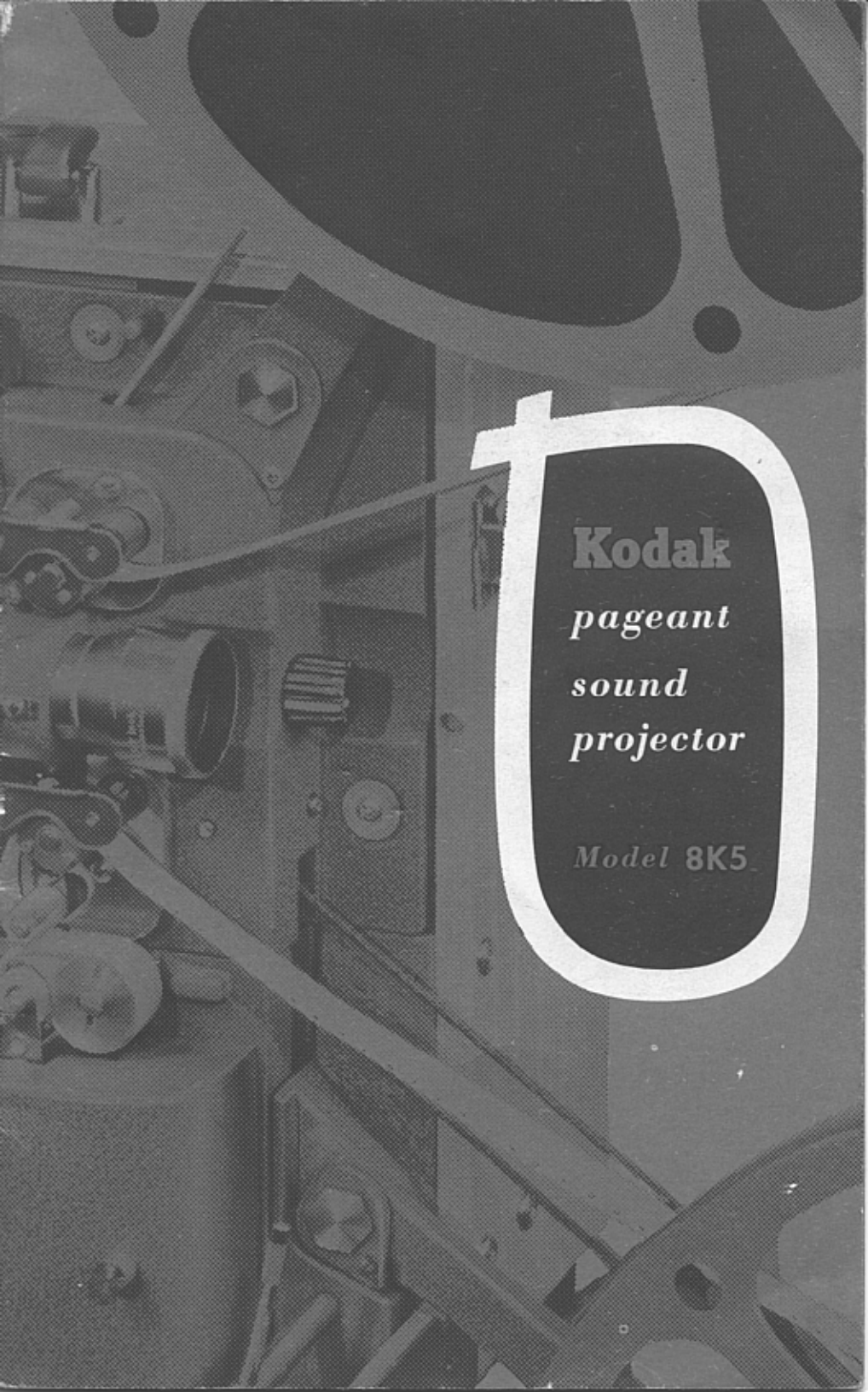

Kodak
*pageant
sound
projector*

Model 8K5

contents

1	Specifications
2	Setting up
5	Preparation for threading
7	Threading for sound pictures
9	Threading for silent pictures
10	Check and run the show
11	Rewinding
12	After the show
12	Microphone
13	Seating arrangements
14	Screen-lamp-lens combination
14	Extra equipment
16	Operating tips
17	Maintenance

* *Kodak pageant sound*



specifications

Approximate WEIGHT	HEIGHT	LENGTH	WIDTH	
lbs.	in.	in.	in.	
40	16½	18½	13¾	Projector packed in corrugated case for shipping
33¼	13	14¼	10¾ ¹⁶	Projector complete
5½	11	14¼	5½	Speaker Unit (Case Cover)

projector MODEL 8K5

Power service required: 105- to 125-volt, 60 cycle ac

Power consumed by projector and amplifier: on 115-volt power line 850 watts with a 750-watt projection lamp; 1100 watts with a 1000-watt projection lamp.

Projection lamp: The lamp supplied is a 750-watt, 115-volt, T-12 bulb, C-13D filament, medium prefocused base; or (optional) 1000-watt, 115-volt, T-12 bulb, C-13D filament, medium prefocused base, 10-hour rating. For optimum illumination and lamp life, it is very important that the projection lamp have a voltage rating approximately (within 2-3 volts) equal to your line voltage.

Input to 9x7-inch oval speaker: 8 watts on 115-volt, a-c line
Exciter lamp: 20 A/T5/2DCP, 7-volt, 0.2 amps.

Tubes: 1-ECC-83; 1-12AX7; 2-35L6GT
Phototube: Cetron, CE-25, Class C

Carefully read and follow the operating instructions presented in this manual.

After a preliminary reading of the operating instructions, practice threading, running, and rewinding with a reel of sound film so that you acquire an easy familiarity with the machine before the first show.

The serial number is stamped on the nameplate below the threading lamp receptacle. Make a record of this number and keep it in a safe place. The serial number should be included in any correspondence about the projector.

Approximate WEIGHT

HEIGHT

LENGTH

WIDTH

5½

33¼

40

11

13

16½

14¼

14¼

18½

5½

10¾¹⁶

13¾

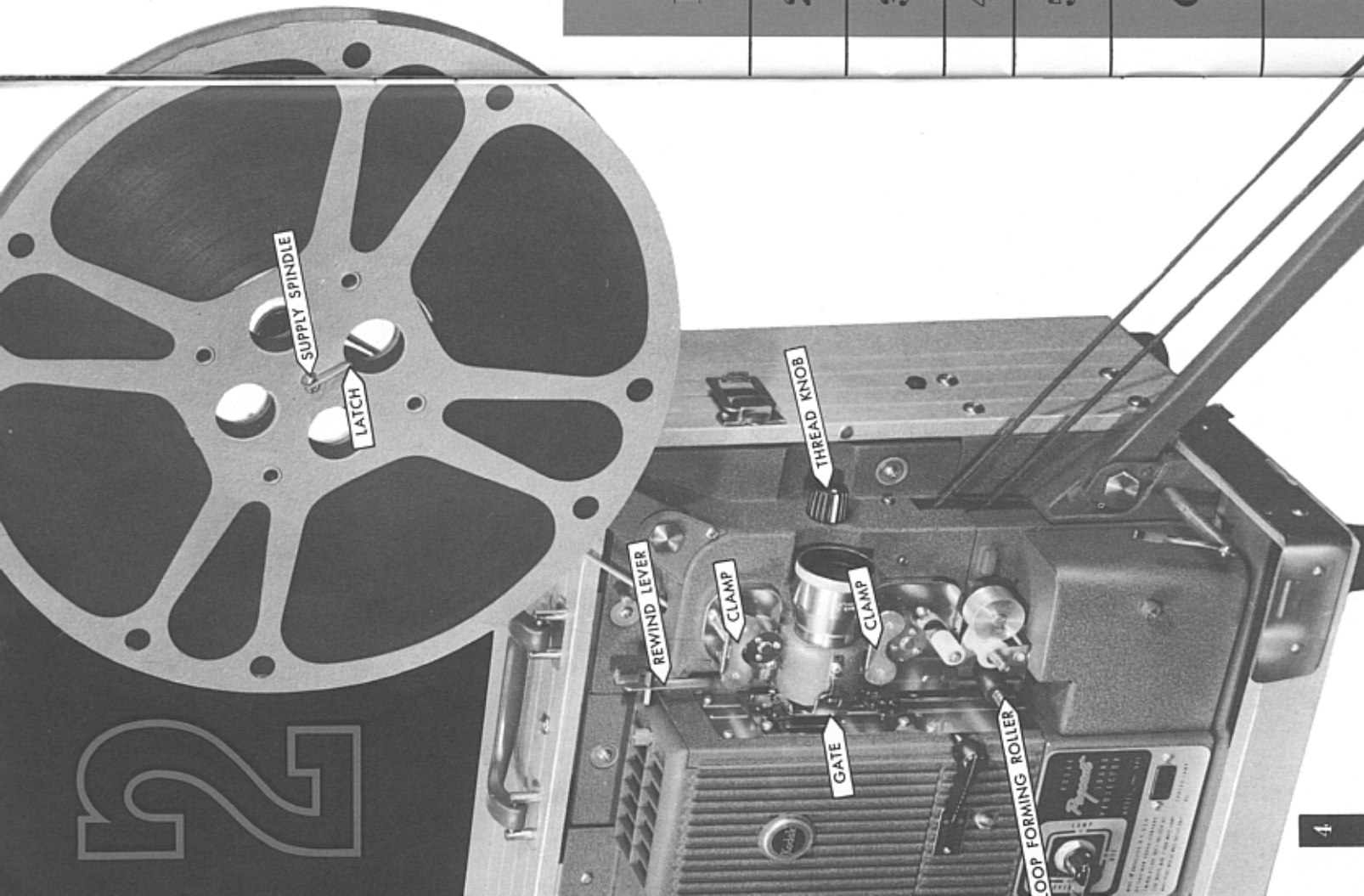

preparation for threading

Place the reel of film on the SUPPLY SPINDLE with the film coming from the bottom of the reel. Lock the reel on to the spindle with the LATCH.

Be sure that the REWIND LEVER is pushed in before threading.

Check to see that the film speed selector is on SILENT or SOUND, as required. (See No. 3, page 6.)

Open the supply and take-up sprocket CLAMPS.

Open the GATE by pushing forward on the tab until it latches.

Turn the trial THREAD KNOB until the white line on the knob is toward you. With the knob in this position, the pull-down is withdrawn, to clear the film channel.

1

2

3

4

5

6

3

threading

...for sound pictures

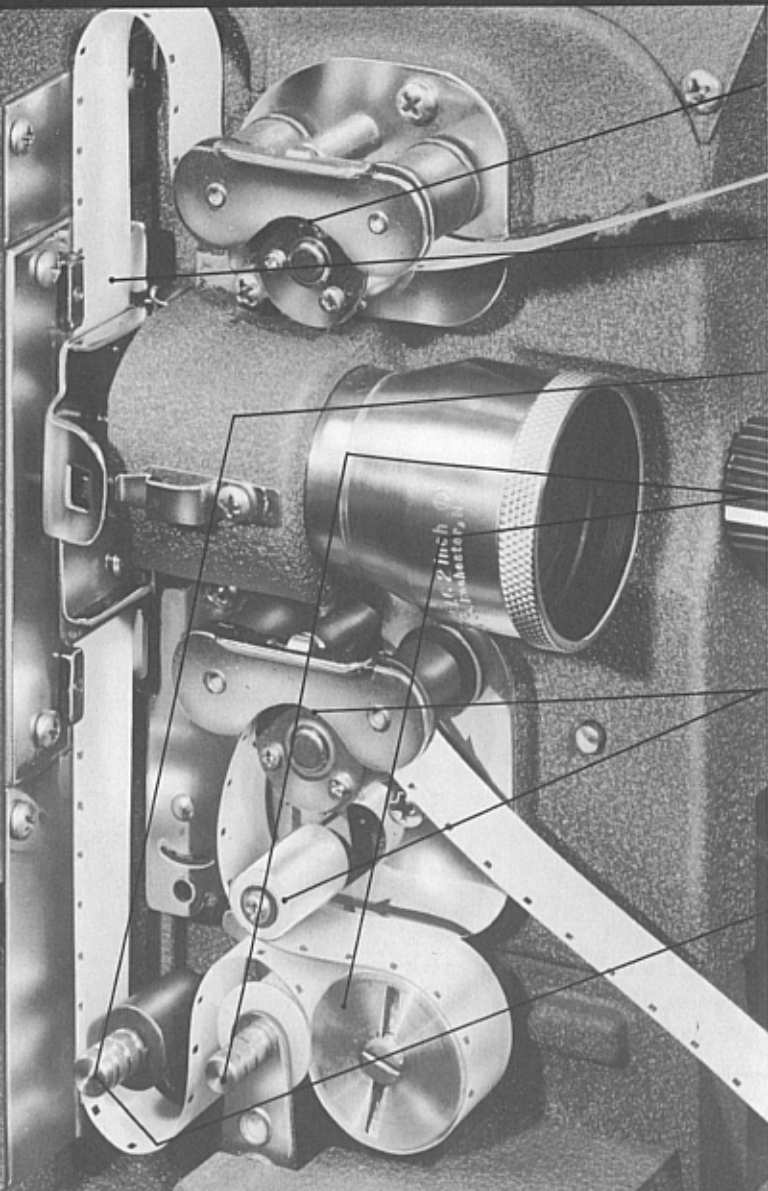

1

Draw off about four feet of film, perforations toward you. Insert the film between the upper sprocket and clamp, engage the film perforations with the sprocket teeth, and close the clamp.

2

Place the film in the film channel between the top and bottom edge guides. Close the gate by pressing on the gate latch. Form the upper loop with the top of the loop even with the red handle on the rewind lever. 

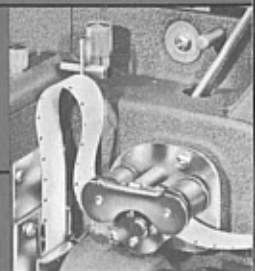

3

Thread the film under the loop-forming roller. The film should just touch the roller.

4

Pull back the sound drum pressure roller and place the film over the roller and under the sound drum. Make sure that the pressure roller is flat against the sound drum and that the film is between the flanges of the roller.

5

Bring the film behind the damper roller and between the take-up sprocket and clamp. Engage the film perforations with the sprocket teeth and close the clamp. Be sure that the film is against the damper roller.

6

Press down on the loop-forming roller as far as it will go; then release, thus forming the upper and lower loops. Turn the trial thread knob to engage the pulldown in the film perforations. The illustration shows the positions of the clamps, the gate, and the film after the loop-forming roller has been pressed down and released.

7

Place the empty reel on the take-up spindle and lock the reel with the latch. Insert the end of the film into the slot in the core of the take-up reel. Take up the slack between the lower sprocket and the take-up reel.

threading

...for silent pictures

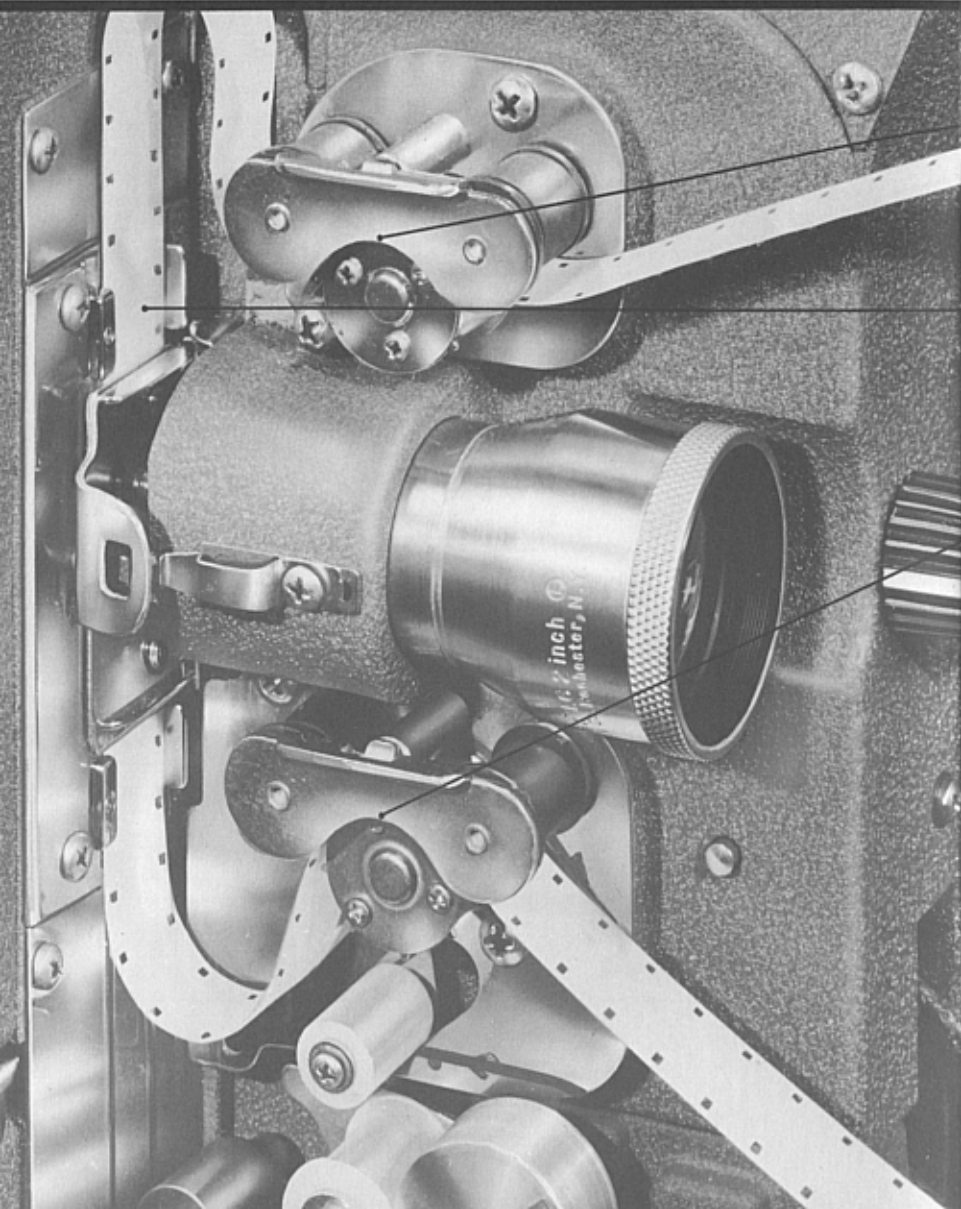

1

Draw off about four feet of film. Insert the film between the upper sprocket and clamp, engage the film perforations with the sprocket teeth, and close the clamp.

2

Place the film in the film channel between the top and bottom edge guides. Form the upper loop as shown and close the gate by pressing on the gate latch.

3

Form the lower loop and thread the film between the lower sprocket and clamp. Engage the film perforations with the sprocket teeth and close the clamp.

4

Turn the trial thread knob to engage the pulldown in the film perforations.

5

Place the empty reel on the take-up spindle and lock the reel with the latch. Insert the end of the film into the slot in the core of the take-up reel. Take up the slack between the lower sprocket and the take-up reel.

4

*check
and run
the show*

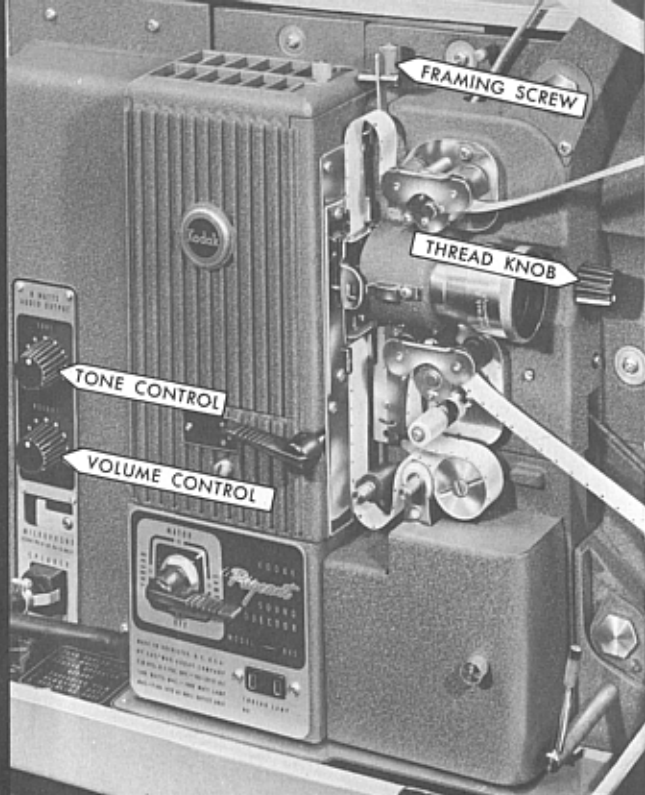

rewinding

When you have finished projecting the pictures, most satisfactory results can be obtained by turning off the projection lamp and by turning the volume control back (counterclockwise) as far as it will go to eliminate the disturbing sounds that sometimes occur when the end of the film is going through the projector. Thread the next reel of film in the projector. With the motor and projection lamp turned on, adjust the volume control for suitable sound. If there are no additional reels to be run, turn the volume control counterclockwise as far as it will go.

To rewind the film, attach the end of the film to the upper reel as shown and give the reel a few turns counterclockwise to bind the film. Make sure that the film is not twisted between the reels. Turn the control switch to MOTOR and set the film speed selector at SOUND. Pull out the REWIND LEVER; the lever is freely pivoted so that it will block the film channel. Proper film tension is automatically maintained by the lower pulley. When all the film has been wound onto the upper reel, *push in the rewind lever as far as it will go* and turn the control switch to OFF.

1

Turn the trial **THREAD KNOB** clockwise a few times to check the threading. The pulldown must engage the perforations, and the sprockets must feed the film.

The size of the loops must be maintained. There should be no slack between the supply reel and the upper sprocket.

2

Turn the control switch to **MOTOR** and check to see that the film is running through properly.

3

Turn the control switch to **LAMP**.

4

Focus the image on the screen.

5

If a blank strip or the edge of the next picture shows at the top or bottom of the screen image, turn the **FRAMING SCREW** until the picture is properly framed.

6

Adjust the **TONE CONTROL** as desired and adjust the **VOLUME CONTROL** to provide comfortable listening.

7

Check to see that the film is being taken up by the lower reel.



after the show

1. Fold the upper and lower reel arms. Be sure to draw the lower reel arm belt in toward the lamphouse.
2. Turn the elevation control clockwise and press down on the top of the projector to engage the elevation lock; then turn the control counterclockwise until it is snug.
3. Unplug the speaker cord and wind it around the hooks in the speaker section.
4. Unplug and coil the power cord. Replace the speaker section on the projector case.
5. Close and fasten the cover.

microphone

Since the microphone circuit is grounded via a condenser and resistor to the power line, it is important that the microphone be properly insulated and shielded; otherwise there is danger of serious shock.

Caution: Use only the Kodak Microphone, Models PA-3 or PA-5, which are adequately insulated and shielded. They are specifically built for this projector and are approved by the Underwriters' Laboratories, Inc.

Microphone with sound pictures—Plug the microphone connector into the microphone receptacle. Regulate the volume and tone in the usual way. Connecting the microphone cuts out the film sound circuit.

Microphone with silent pictures—Turn on the amplifier and connect the speaker as for sound pictures. Regulate the volume and tone in the usual way. Do not turn up the volume too far, or howling ("feed back") will result.

Matte Screen

The colored area shows the best viewing area for matte screens.

The seats nearest the screen should not be closer than twice the width of the picture ($2W$); the rear seats should not be farther than six times the width of the picture ($6W$).

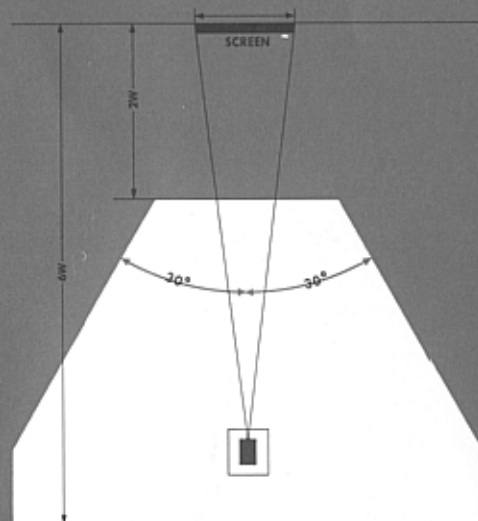

seating arrangements

Beaded Screen

The colored area shows the best viewing area for beaded screens.

The seats nearest the screen should not be closer than $2\frac{1}{2}$ times the width of the picture ($2\frac{1}{2}W$); the rear seats should not be farther than six times the width of the picture ($6W$).

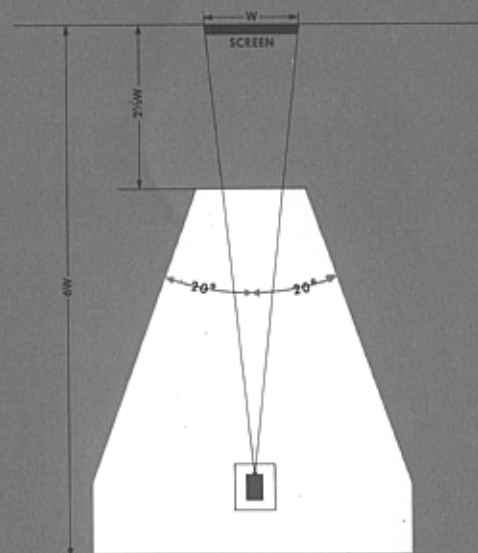

screen · lamp · lens combination

Proper selection of screen, lamp, and lens for your particular setup is important. The screen image should be of adequate size and brilliance; it should not be too bright nor too dark. With the wide variety of lamps and lenses available for your Pageant Projector, you can tailor your equipment to suit your needs. The graphs on page 15 show you the results of the various combinations when a 750-watt lamp or a 1000-watt lamp is used.

The heavy portion of each line, from A to C, shows the range of image sizes which will provide acceptable size and brilliance for comfortable viewing on *matte screens*.

The B point shows the recommended image size for best projection on a matte screen. The screen image will be neither too bright nor too dark.

The A point shows the smallest and brightest screen image that should be used. The C point shows the largest and darkest screen image that should be used.

The D point shows the recommended image size and brightness for *beaded screens* when the maximum viewing angle is 20° or less.

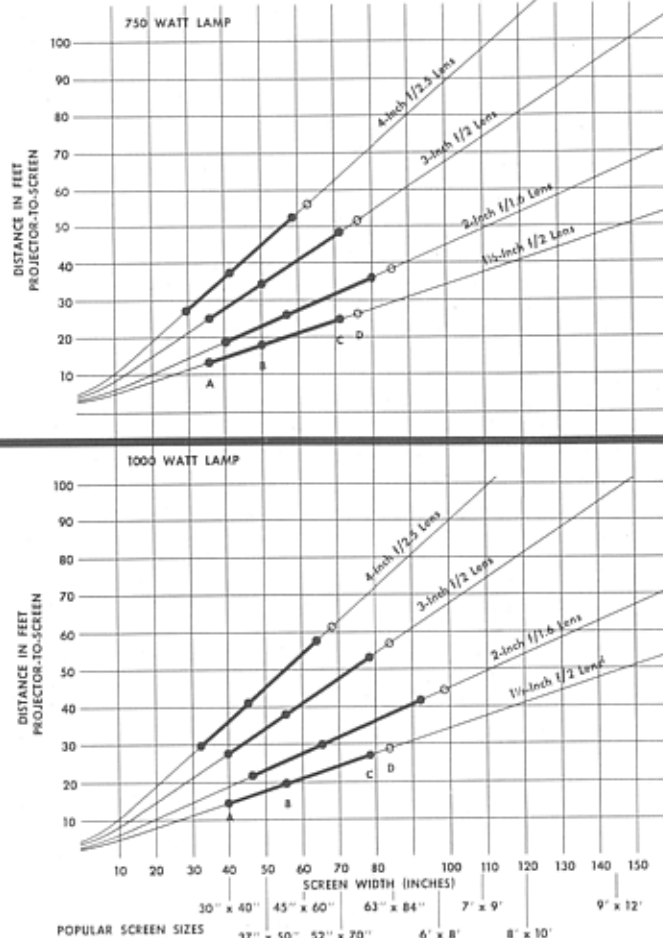

extra equipment

Cine-Kodak Bifocal Converter (for Kodak Projection Ektanon Lens, 2-inch $f/1.6$)—Shortens the effective focal length to $1\frac{5}{8}$ inches or lengthens it to $2\frac{1}{2}$ inches, depending on which end of the converter is placed next to the basic lens.

Kodak Microphone, Models PA-3 and PA-5—Either microphone readily plugs into the Pageant Model 8K5 for commentary with silent films, or to convert the projector to a public-address system.

Kodak Phono Adapter, Model PP-3—The adapter and a suitable turntable unit make possible the playing of phonograph records through the

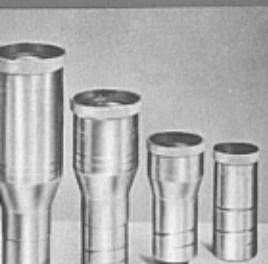

projector's fine sound system.

Note: Do not use the adapter with a microphone.

Kodak Projection Ektanon Lenses—Three additional Ektanon lenses are available for Kodak Pageant Sound Projectors: $1\frac{1}{2}$ -inch $f/2.0$, 3-inch $f/2.0$, and 4-inch $f/2.5$. A 2-inch $f/1.6$ lens is standard equipment with the projector. Consult the above graphs to determine the relationship

of screen width and projector-to-screen distance.

35-foot Speaker Extension Cord—This extension cord permits the speaker to be used at greater distances from the amplifier than would otherwise be possible, or for the cord to be run indirectly from projector to speaker so that it will be out of the way. Make all speaker-to-amplifier connections before turning on the amplifier.

operating tips

The perforations in sound film should be toward you as the film comes off the bottom of the supply reel. If they are not toward you, the film has not been rewound or was twisted while being rewound.

The projected picture will be out of focus if the gate is left open during projection.

To avoid shortening the life of the exciter lamp, do not leave the amplifier on when the projector is not in use.

Do not leave the amplifier on if the exciter lamp is not lighted.

If there is no sound, check to make sure:

Speaker cord is connected.

Amplifier is turned on—turn control switch clockwise to **THREAD**.

Sound track is overriding edge of sound drum properly.

Film is between the flanges of sound drum pressure roller.

Exciter lamp is not burned out and is located on all three studs.

Tubes or photocell is not burned out.

Photocell and power connectors are connected to amplifier.

If the sound quality is not up to par, check to make sure:

Film speed selector is at **SOUND** position.

Lower loop is of the proper size.

Film is snug around sound drum and sound drum is clean.

Volume is not too high.

Tone control is correctly adjusted.

Film sound track is of good quality.

If the picture on the screen is unsteady, check both the upper and the lower loops; these must be maintained. The lower loop should not touch the exciter lamp cover. Loss of the loop is caused by torn perforations in the film or improper threading.

The sprocket teeth must show through the perforations on the film. Make sure that the sprocket clamps and the gate are closed. Any sections of film containing torn perforations should be cut out before the film is run again.

If loss of loop occurs—*sound film*, quickly press down on the loop forming roller as far as it will go while the machine is running; then release the roller; *silent film*, stop the motor immediately and reform the loops.

If the machine is stopped while projecting a reel of film, turn the trial thread knob several turns clockwise to take up any slack between the lower sprocket and the sound drum.

maintenance

cleaning film gate and aperture

The **GATE**, which holds the film as it passes the lens, should be cleaned at frequent intervals. Because of the rapid stop-and-go motion of the film, particles of the coating and emulsion are eventually rubbed off the edges of the film and lodge on the gate. If these are allowed to build up, they will cause excessive wear of the film.

Use care when removing or replacing the gate; force is not necessary.

Turn the trial thread knob until the white line is toward you to retract the pulldown. Remove the projection lens.

Open the gate and insert a clean card or piece of paper to protect the polished surfaces of the gate. Then remove the gate by pressing the gate tab toward the back of the projector. This releases the hinge and allows you to withdraw the gate.

Use a soft, damp, lintless cloth to clean the gate. If necessary, wrap the cloth around a toothpick or match stick to clean the film track.

To clean the aperture, reach through the projection lens holder with a small, soft brush and dust off the edges of the aperture. Be careful not to chip off the black coating on the edges.

Before replacing the gate be sure the pulldown is retracted. Then guide the upper notched part of the gate so that it bears against the under part of the top hinge retaining **SPRING**. Push in on the gate tab to engage the top and bottom hinges.

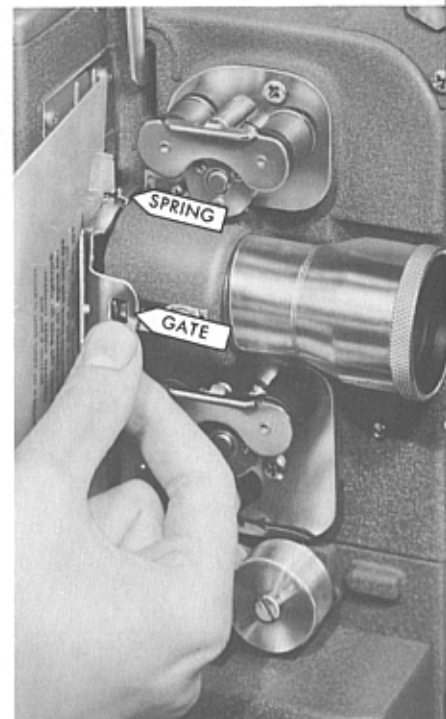

cleaning lenses

The condensing and projection lenses are Lumenized; that is, a special hard coating has been applied to all the air-glass surfaces. The tinted appearance of the lenses is due to this treatment, which increases the brilliance and quality of the image on the screen.

Like any fine lens, the projection lens should be cleaned with care. Remove the lens by drawing it out of the lens holder. With a soft, lintless cloth or Kodak Lens Cleaning Paper carefully wipe the front and rear surfaces. Do not use a wet cloth; if moisture is required, breathe on the lens or use a drop of Kodak Lens Cleaner.

WARNING: The use of treated papers and cloths should be avoided as they may harm the lens coating.

To clean the condenser lens and reflector, loosen the lamphouse cover screw, and lift off the LAMPHOUSE COVER. Remove the lamp by pushing it down and twisting it counterclockwise to release it and then lift it out. Push the ARM back toward the framing screw and lift out the condenser lens. Carefully wipe the front and back surfaces. If the inside surfaces need cleaning, pry out the wire spring and remove the lenses. Clean both surfaces of the lenses. Replace the lenses with the curved sides inward; see diagram. Replace the unit; apply a light pressure forward while turning the handle clockwise to lock the condenser mount ears under the lugs on the lamp housing.

Clean the reflector using a soft, lintless cloth or Kodak Lens Cleaning Paper.

Replace the projection lamp with the larger flange on the lamp base toward the projection lens. Push the lamp down and give it a quarter-turn clockwise to lock it in position.

Replace the lamphouse cover and tighten the lamphouse cover screw.

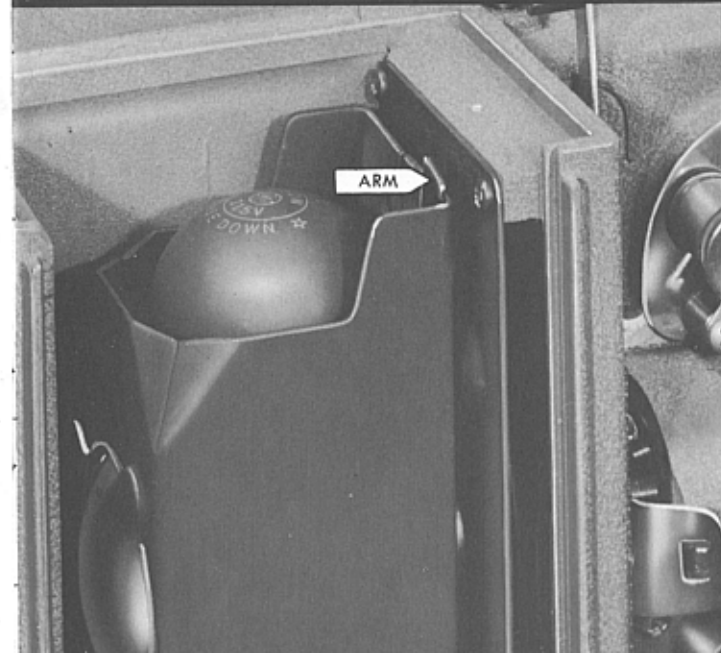
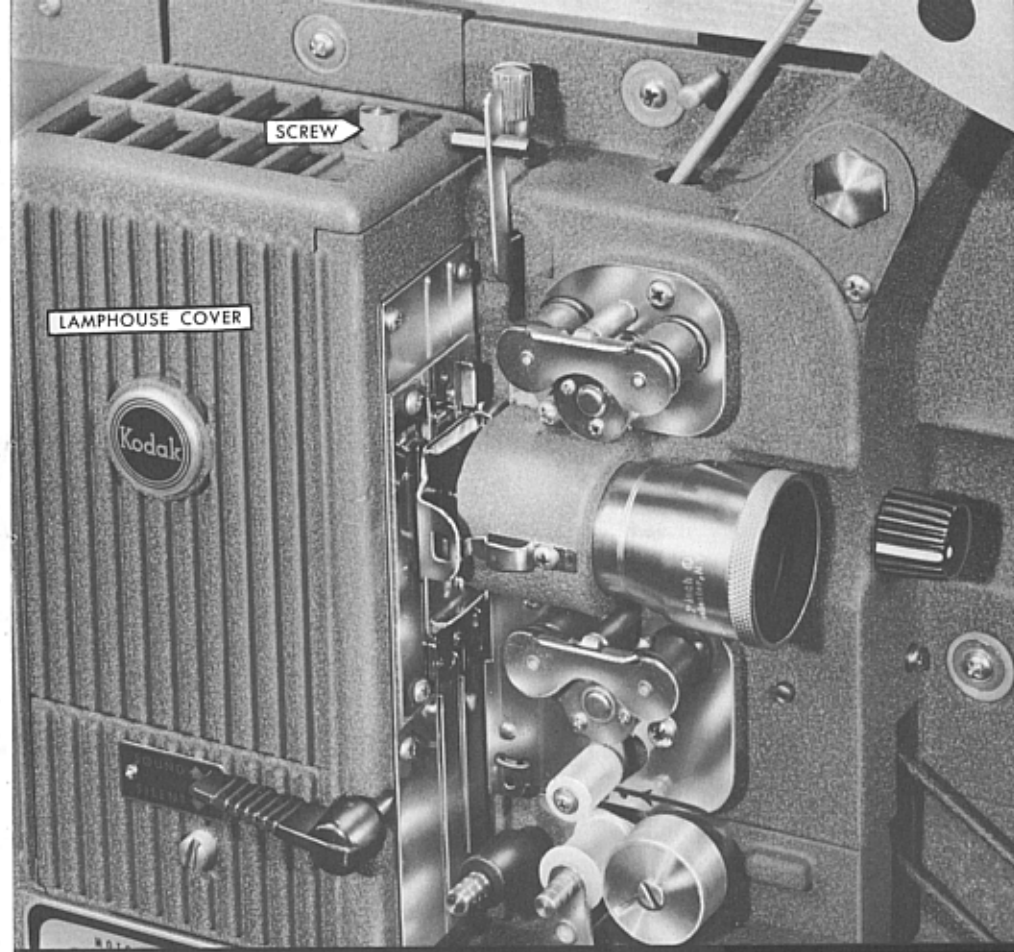
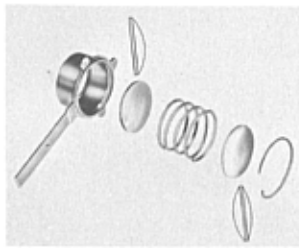

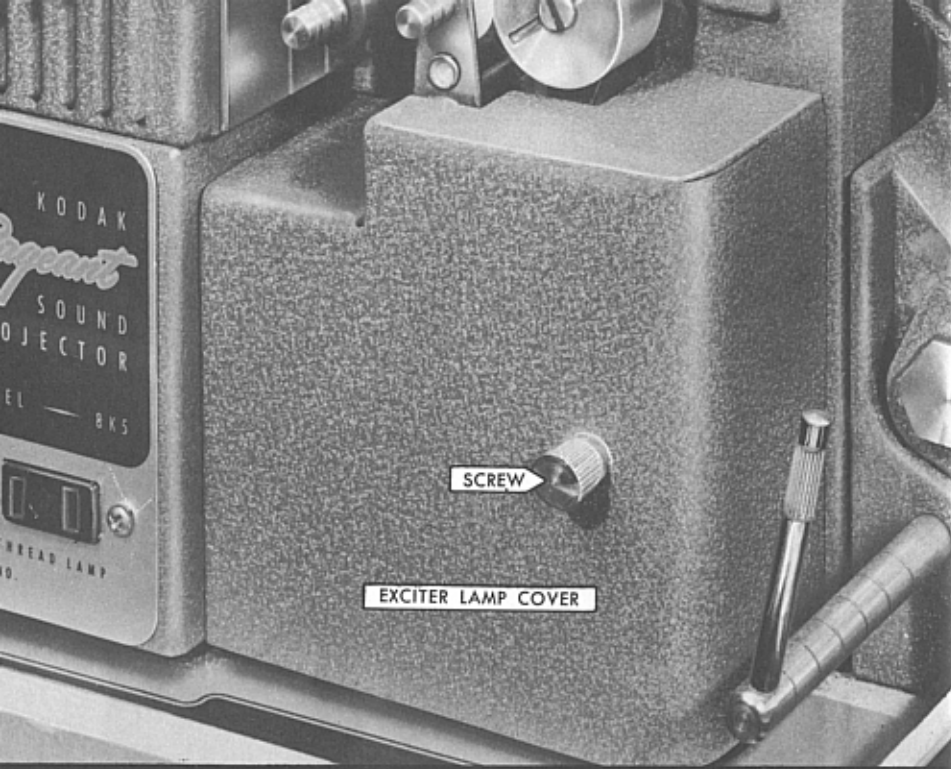

cleaning sound optics

Remove the **EXCITER LAMP COVER** by loosening the knurled cover **SCREW** and lifting the cover off. With a soft brush, dust both lenses in the optics as shown in the illustration on page 20. There is a lens in each end of the assembly.

Just above the upper lens and directly behind the sound drum is the **SOUND PICK-UP**. The lower surface of the pick-up should be kept clean with a soft brush. If necessary, a soft, lintless cloth wrapped around a small stick can be used to polish the surfaces. Replace the exciter lamp cover.

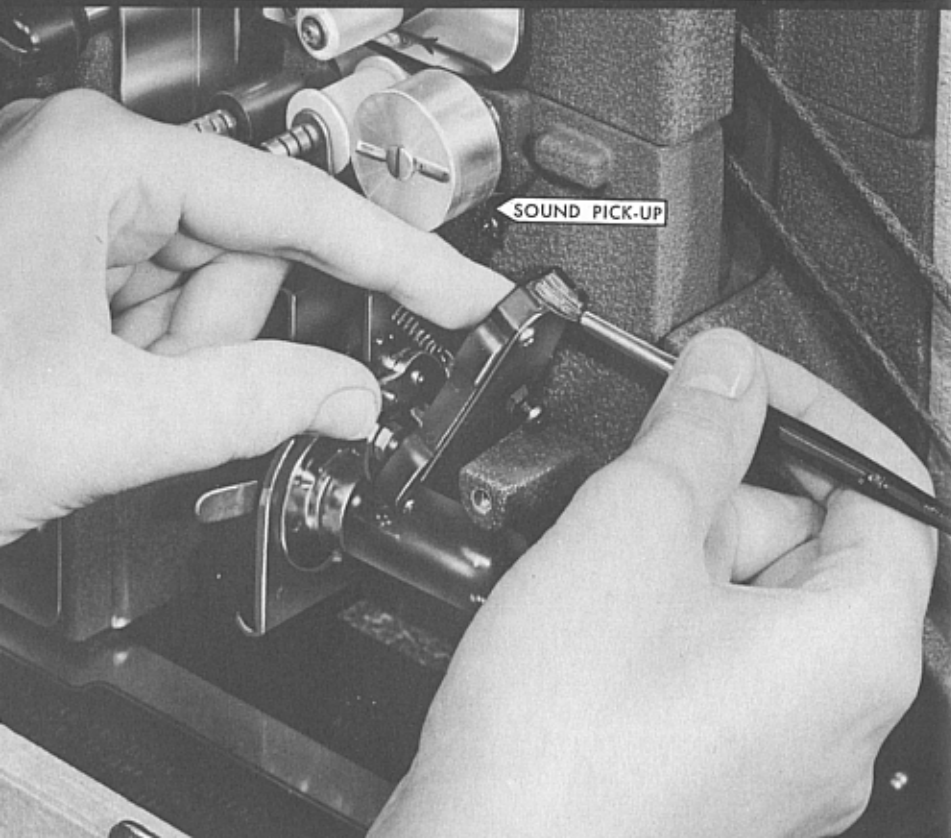

cleaning sound drum

The sound drum, sprocket clamp rollers, and other rollers which come in contact with the film should be wiped with a soft, lintless cloth occasionally to keep them clean. If emulsion and dust build up on the sound drum, the quality of the sound will be impaired.

Dirt particles on the inner edge of the sound drum interrupt the light beam and produce objectionable noises. To test for this, turn the sound drum while the amplifier is on. Do not use film in the projector during this test.

oiling

All bearings are self-lubricating and require no oiling.



replacing lamps

Projection Lamp—Loosen the lamphouse cover screw, and lift off the lamphouse cover.

Warning: High-wattage lamps get very hot in use. Be sure to allow time for cooling before handling them. Cooling can be accelerated by unthreading the projector and running the motor.

For best results, select a lamp with a voltage rating approximately (within 2-3 volts) equal to your line voltage.

Remove the lamp by pushing it down and twisting it counterclockwise to release it; then lift it out.

Replace the lamp with the larger flange on the lamp base toward the projection lens. Push the lamp down and give it a quarter-turn clockwise to lock it in position. Replace the lamphouse cover.

If necessary, adjust for evenness of illumination by turning the lamp centering screw.

Exciter Lamp—Remove the EXCITER LAMP COVER by loosening the knurled cover screw and lifting the cover off. Push the exciter lamp RELEASE LEVER down as far as it will go. Twist the lamp counterclockwise and remove it.

Place the new lamp in the socket and turn it until the large end of the key slots in the lamp base fits over the three locating studs. The lamp will fit only one way. Twist the lamp clockwise as far as it will go. Raise the exciter lamp release lever up to lock the lamp in position.

NOTE disconnect power cord before replacing electrical parts

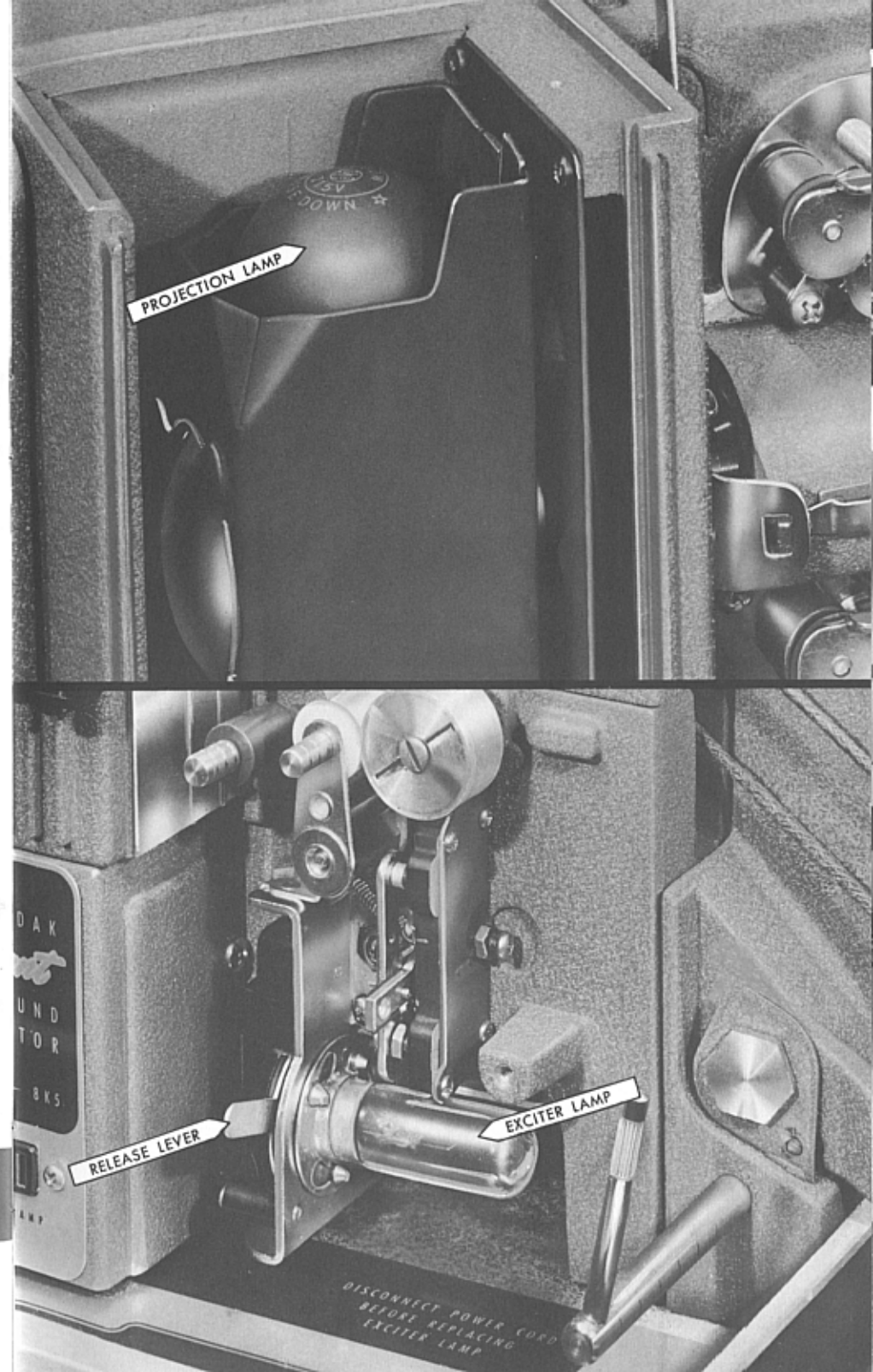



NOTE disconnect power cord before replacing electrical parts

replacing belts

Rewind Belt—If one end of the rewind belt protrudes, attach the new belt to it and pull it through. Disconnect the worn belt and connect one end of the worn belt to one end of the new belt. If the old belt is not in position, feed the new belt into the opening in front of the upper reel arm. Guide the belt between the flanges of the pulley until the end protrudes from the opening in the top of the housing. If the end of the belt hits against the housing, use a bent paper clip to guide it.

Take-Up Belt—The worn belt can be removed most easily by cutting it and pulling it out of the mechanism. To install the new belt, push in on the belt guard release post, using the flat side of a coin as a thumb piece, until the post is flush with the mechanism housing. Holding the belt as shown, push the looped end of the

NOTE disconnect power cord before replacing electrical parts

replacing tubes

Remove the volume and tone control knobs; they are held on by friction and are readily pulled off. Remove the three screws from the amplifier cover, and lift it off. Replace the tubes according to the diagram on the side of the amplifier. The ECC-83 tube is located under the input circuit shield. To replace this tube, the amplifier should be removed as described below.

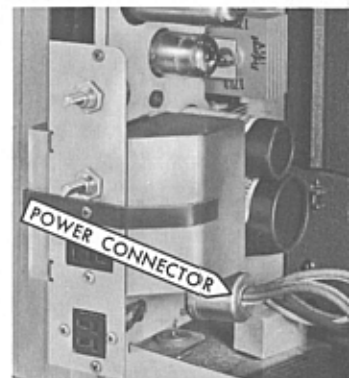

removing amplifier

If the amplifier requires repair, it should be done by a competent serviceman. Remove the knobs and the amplifier cover as described above. Remove the two screws on the back of the case behind the amplifier and the screw on the bottom of the case directly under the amplifier. Withdraw the amplifier sufficiently to disconnect the power connector. Then remove the input circuit shield. Disconnect the photocell plug. Remove the amplifier. In reinstalling the amplifier, be sure both cables are reconnected.

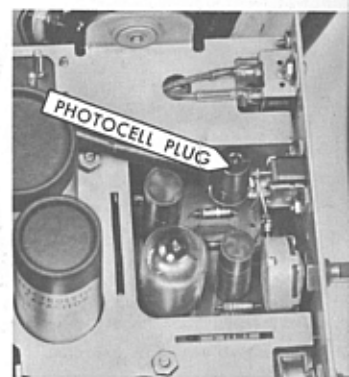

belt into the opening in the mechanism. The belt guard will guide the belt into position on the pulley. Allow the belt guard release post to return to its original position. This restores the belt guard to its normal position and insures that the belt functions properly. Slip the belt around the take-up pulley, starting at the edge of the pulley and pushing the belt inward between the pulley and the guard. Be sure the belt is not crossed.

Drive Belt—This belt will seldom need replacing. It is recommended that your serviceman make replacement; however, complete instructions are furnished with replacement belts.

