

# FILM-TECH

**THE INFORMATION CONTAINED IN THIS ADOBE ACROBAT PDF FILE IS PROVIDED AT YOUR OWN RISK AND GOOD JUDGMENT.**

**THESE MANUALS ARE DESIGNED TO FACILITATE THE EXCHANGE OF INFORMATION RELATED TO CINEMA PROJECTION AND FILM HANDLING, WITH NO WARRANTIES NOR OBLIGATIONS FROM THE AUTHORS, FOR QUALIFIED FIELD SERVICE ENGINEERS.**

**IF YOU ARE NOT A QUALIFIED TECHNICIAN, PLEASE MAKE NO ADJUSTMENTS TO ANYTHING YOU MAY READ ABOUT IN THESE ADOBE MANUAL DOWNLOADS.**

[WWW.FILM-TECH.COM](http://WWW.FILM-TECH.COM)

# CONSTRUCTION PLANS

## SG STEREO GENERATOR

The PANAXIS Stereo Generator (SG) consists of audio processing and time division multiplex circuitry. Precision IC amplifiers, crystal derived pilot and sub-carrier frequencies, and double-balanced modulation makes this an extremely clean stereo generator. Operating characteristics meet and in some cases exceed FCC specs for commercial broadcast service.

### SPECIFICATIONS

Audio Response	20 - 20 kHz (with active filter)
Distortion	.5% or less at 100% output
Noise	65 dB below 100% output
Separation	40 dB or better
Left to right balance	.5 dB or better
Subcarrier null	50 dB typical
Pilot stability	19 kHz within 2 Hz
Audio input impedance	600 ohms or 10K ohms
Audio input level	-10 dBm for 100% output
Output impedance	600 ohms minimum
Output level	0 dBm into 600 ohms
Power requirements	+12, -12 volts at 200 ma.

### THEORY OF OPERATION (see schematic diagram)

There are several sections to discuss. Each will be treated separately. There are the pre-emphasis amplifiers (IC x, pins 1 and 14), the active filters (IC x, pins 7 and 8), the summing and difference amplifiers (IC y, pins 1 and 7), the balanced modulator (IC z), the crystal oscillator-divider-19 kHz/38 kHz filters (IC u,v,w), and the output amplifier (IC y, pin 14).

An audio signal is injected at R7 (600 ohm -10dBm). R8 and C12 form a standard 75 microsecond pre-emphasis network. The following amplifier therefore boosts the audio signal about 17 dB at 15 kHz, but only 0 dB at 400 Hz. A look at Fig. 3 will show this clearly. See the dashed line marked 75 uS. Note that the amplifier below this one is exactly the same - audio is injected at R35. One amplifier is for the left channel, the other is for the right channel.

The output of the first amplifier is taken from pin 1. It is fed to the input of an active filter (R10,C14,R11,C15,R12,R13,C16). The output is taken from pin 7 of the IC. The response of this amplifier is shown in Fig. 2. Plot a begins roll-off at 10KHz while plot B begins roll-off at 15 kHz.

The active filter is used to shape the audio response to help reduce interference often encountered when playing very high fidelity recordings. Although these recordings are fine for listening through a stereo amplifier system they can sometimes cause problems in stereo broadcast transmissions. The reason is that these recordings contain a lot of high frequency components, some of which can not even be heard by the human ear. The standard pre-emphasis used in FM transmitters boosts these frequencies more than it does for mid-range frequencies (see Fig. 3). The result is a mixing of these frequencies with the 19 kHz pilot and 38 kHz sub-carrier frequencies. This produces sum and difference frequencies which can be heard by the listener. They are heard as whistles, squeaks, chirps, or just a general rushing noise.

The active filter begins to reduce audio response above a certain frequency as shown in Fig. 2. This combined with the pre-emphasis curve produces an overall response similar to plot A or B in Fig. 3. What the listener will hear however is what is shown in Fig. 2. Plot A of Fig. 2 shows a reduction of 3 dB at 10 kHz and about 5 dB at 15 kHz, and 13 dB at 19 kHz. The overall response will actually have some peaking around 9 kHz. Only the most critical hi-fi listener would notice much difference in high frequency response. If you do find this objectionable and want more high's you can elect to use plot B. Here there is a 3 dB drop at 15 kHz but only a 9 dB drop at 19 kHz. See parts list for active filter component values.

The output from the left and right active filters (pins 7 and 8) are fed to summing and difference amplifiers. IC y, pin 7 has an output called L-R (left minus right). This is fed thru C17 to the modulation input of the balanced modulator IC z. The output of IC y, pin 1 is the inverted sum of the left and right signals. It is fed to a summing junction (R49, R47, R48, and R45) thru R45.

Off of the audio for a moment while we generate our pilot and sub-carrier..... IC u has two of its 6 amplifiers connected as a crystal oscillator. The oscillator is followed by one more amplifier to assure good clean square waves. These are fed directly to IC v at pin 1. This IC divides the 4.864 MHz crystal frequency by 16 giving a 304,000 Hz output at pin 12. This is fed directly into IC w at pin 1. IC w divides its input frequency by 8 giving an output of 38,000 Hz at its pin 14. This is amplified by one of IC u's amplifiers and is fed to a filter (R3, C2, L1, C3) This produces a fairly good sine wave which is fed to the carrier input of the balanced modulator (IC z, pin 8). IC w also divides again by 2 and gives an output of 19,000 Hz at its pin 12. This is also amplified and fed to a filter (R4, C4, L2, C5, R53) then to the summing junction thru R46.

The balanced modulator should only produce an output when it has an audio input. Careful adjustment of R30 (trim pot) provides balancing of the circuit. The sub-carrier (38,000 Hz) is almost completely eliminated (down 50 dB typical). This is your sub-carrier null adjustment. The output from the balanced modulator is fed to the summing junction thru R25, C28, and R47.

We now have a left + right signal across R49 (from R45). We also have our left minus right signal superimposed on a 38,000 Hz sub-carrier across R49 (from R47). Adjustment of R47 matches levels between the L + R and the L - R (see Fig. 6). This adjusts your stereo separation.

The 19,000 Hz pilot frequency is introduced to R49 thru R46. Movement of the swinger on R49 adjusts the amount of the pilot injection. This is normally set for 10% modulation but may be adjusted to as much as 12% modulation. This level could have been fixed, however by making it adjustable all the way to zero permits more accurate testing and alignment.

The summing junction is connected to the input of an amplifier thru R48. The output of the amplifier is taken from R51 to trim pot R52. Adjustment of R52 permits accurate setting of the input level to an FM exciter. This is a broadband amplifier with a response up to about 100,000 Hz. The composite stereo signal contains frequencies up to about 53 kHz. This allows some "rounding" of the square wave pulses which come out of the balanced modulator—thereby reducing another source of possible noise. Output is 0 dB into 600 ohms at full output.

Back to the input. If a higher input level is desired you may install R5 and R34. If these are made 10K ohms it will require about a + 10 dBm input to obtain 100% output of 0 dBm into 600 ohms. If the input must be matched to a 600 ohm source AND you have R5 and R34 installed then you must install R6 and R33. C10 and C20 are shown for your convenience, they are not installed on the pc board. In areas of high radio frequency energy (near a high power transmitter) you may want to install .005 uF disc capacitors at these points - probably at your audio connector or terminal strip lugs.

The voltage regulator, IC t, provides a stable +5 volts for the digital logic IC's u, v, and w. Additional filtering is used on both the + 12 volt and the - 12 volt inputs both for stabilization of the dc but also for suppression of transient spikes.

### PARTS SOURCES

Parts for the PANAXIS Stereo Generator are available from many sources. If you can not locate the necessary parts in your area you might want to order from the following companies.

MOUSER ELECTRONICS  
11433 Woodside Ave  
Santee, CA 92071  
619-449-2222  
(free catalog available)

JAMECO ELECTRONICS  
1355 Shoreway Rd  
Belmont, CA 94002  
415-592-8097  
(free catalog available)

PANAXIS  
Box 130  
Paradise, CA 95969  
916-534-0417  
(kit and/or parts)

PARTS LIST

Qty	Part #	Description/clr code	(Inductors)
(Resistors - 1/4 watt)			(2) L1,L2 560 uH
(3)	R1,2,32	470 ohm Yl/Vi/Br	
(5)	R3,4,20,21,53	51 ohm Gn/Br/Bk	(Semiconductors)
* (2)	R5,34	10K Br/Bk/Or	(1) T 7805
* (2)	R6,33	620 ohm Bl/Rd/Br	(1) U 74LS04
(2)	R7,35	620 ohm Bl/Rd/Br	(2) V,W 74LS93
(4)	R8,9,36,37	75 K Vi/Gn/Or	(2) X,Y TL074 or 84
(6)	R10,11,13, 38,39,41	** 27K Rd/Vi/Or	(1) Z LM1496
(2)	R12,40	** 56K Gn/Bl/Or	(1) D1 1N5237B
(6)	R14,15,16,17, 42,43	24K Rd/Yl/Or	(Crystal)
(3)	R18,22,28	1K Br/Bk/Rd	4.864 MHz .005% HC-18
(1)	R19	6.8K Bl/Gy/Rd	Misc.
(2)	R23,24	3.9K Or/Wh/Rd	(6) 14 pin IC sockets
(4)	R25,27,29,46	100K Br/Bk/Yl	(1) printed ckt board
(2)	R26,31	10 K Br/Bk/Or	(1) 4-40 x 1/4 screw
(1)	R30	50K trimpot 3/8" square	(1) 4-40 nut
(1)	R44	12K Br/Rd/Or	#24 insulated wire
(1)	R45	20K Rd/Bk/Or	Red (+12 volts) 6"
(1)	R47	100Ktrimpot 3/8" square	Blue (-12 volts) 6"
(1)	R48	5.1K Gn/Br/Rd	Black (ground) 18"
(1)	R49	5K trimpot 3/8" square	Yellow (right channel) 6"
(1)	R50	220K Rd/Rd/Yl	Green (left channel) 6"
(1)	R51	120 ohm Br/Rd/Br	White (output) 6"
(1)	R52	1K trimpot 3/8" square	
(Capacitors - 16 volt minimum rating)			* Items marked with one asterisk are not furnished with the kit- they are of optional use.
(9)	C1,11,12,14,15, 21,22,24,25,	(5% tolerance) .001 poly or ceramic	** values shown are for active filter curve A and are furnished with the kit. For curve B use 6 each 24K and 2 each 47K instead of values shown above.
(8)	C2,3,4,5,7,8, 28,32	(5% tolerance) .1 poly or ceramic	
(1)	C6	4.7 uF tantalum	
(2)	C9, 19	330 uF radial type	
* (2)	C10,20	.005 uF ceramic disc	
(4)	C13,18,23,27	.1 uF tant. or ceramic	
(2)	C16,26	100 Pfd mini disc ceramic	
(1)	C17	10 uF radial type	
(1)	C30	47 uF radial type	
(1)	C31	.01 uF poly or ceramic	
	C29	not used	

STEREO GENERATOR, Cont'd.

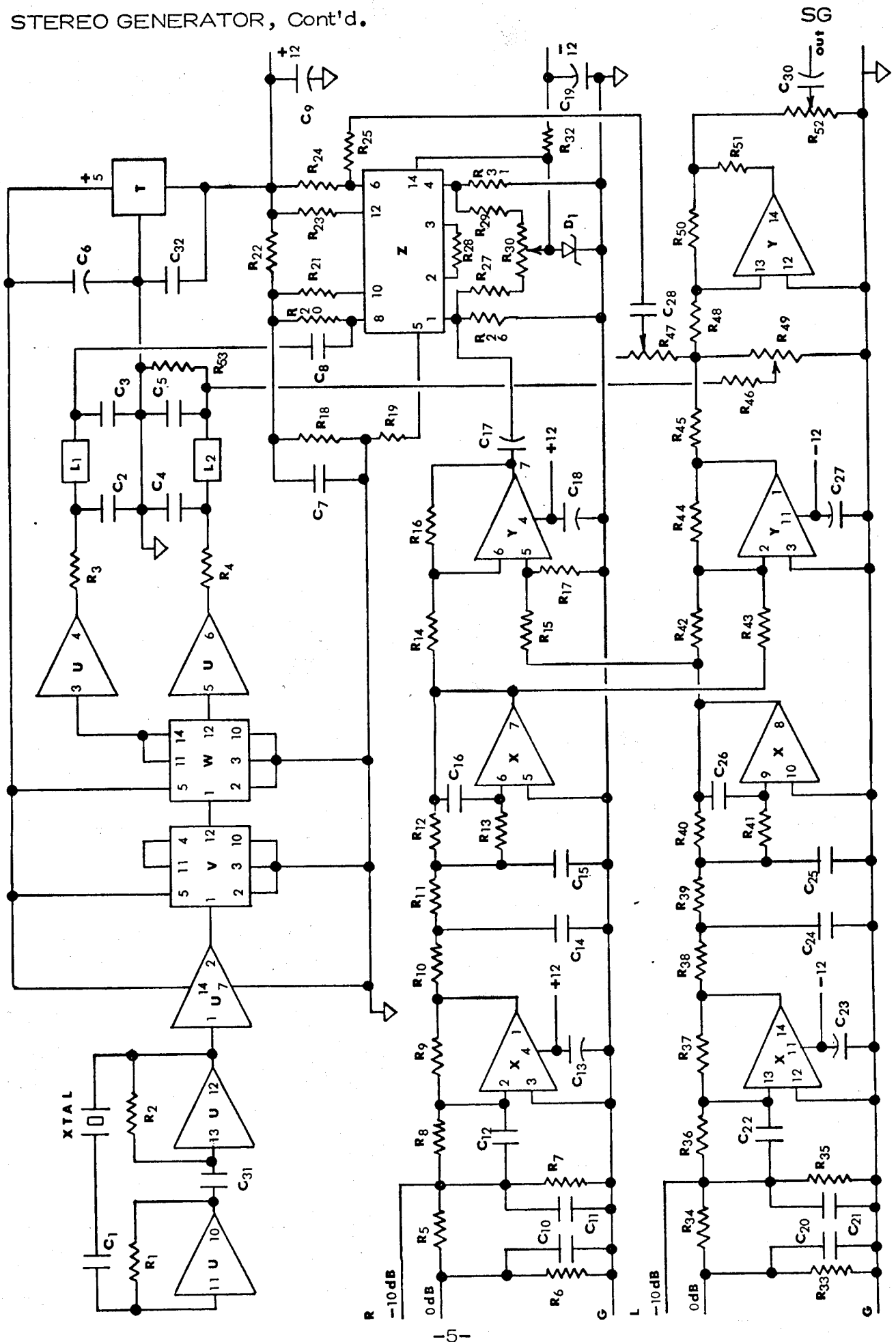
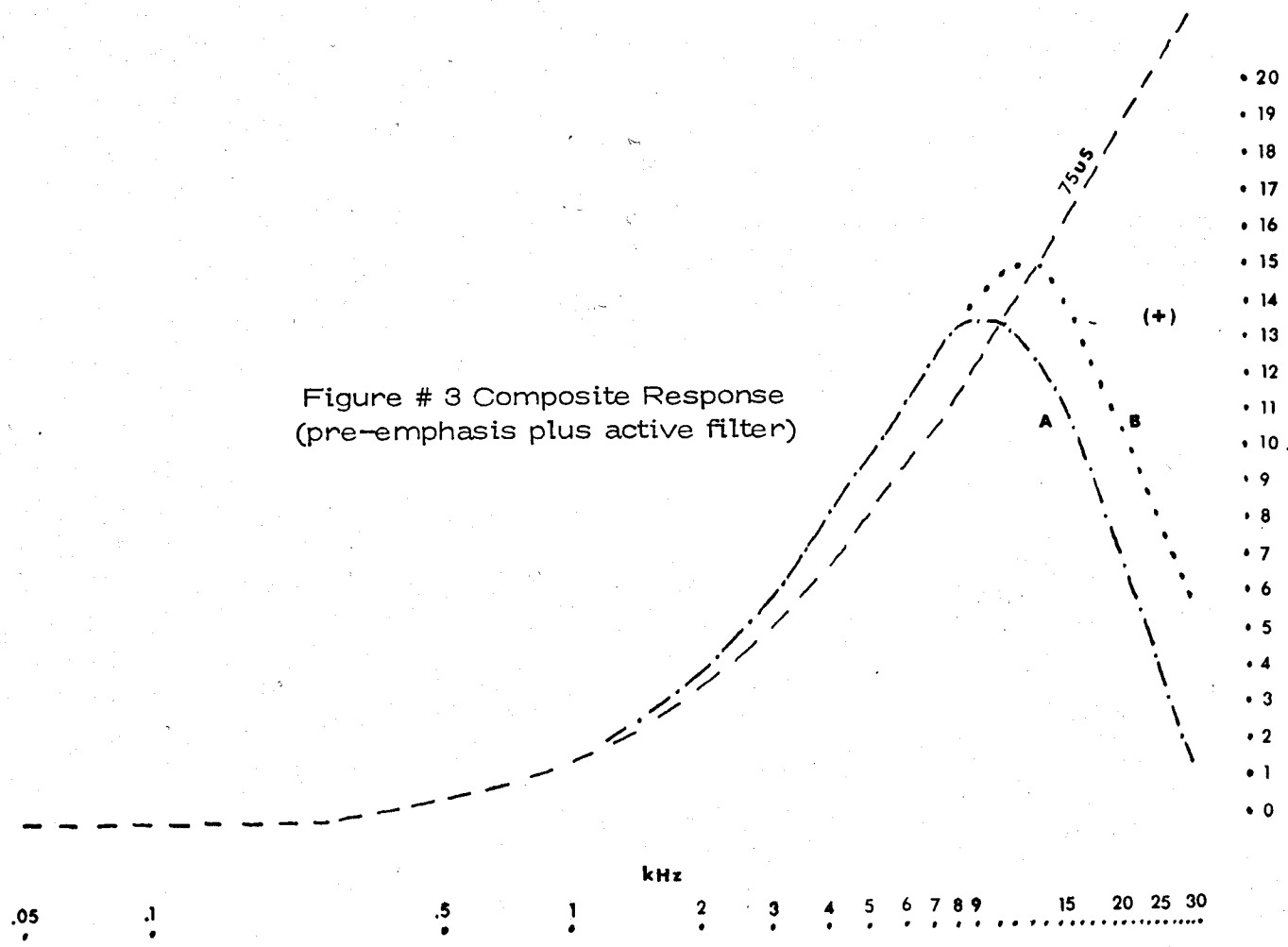
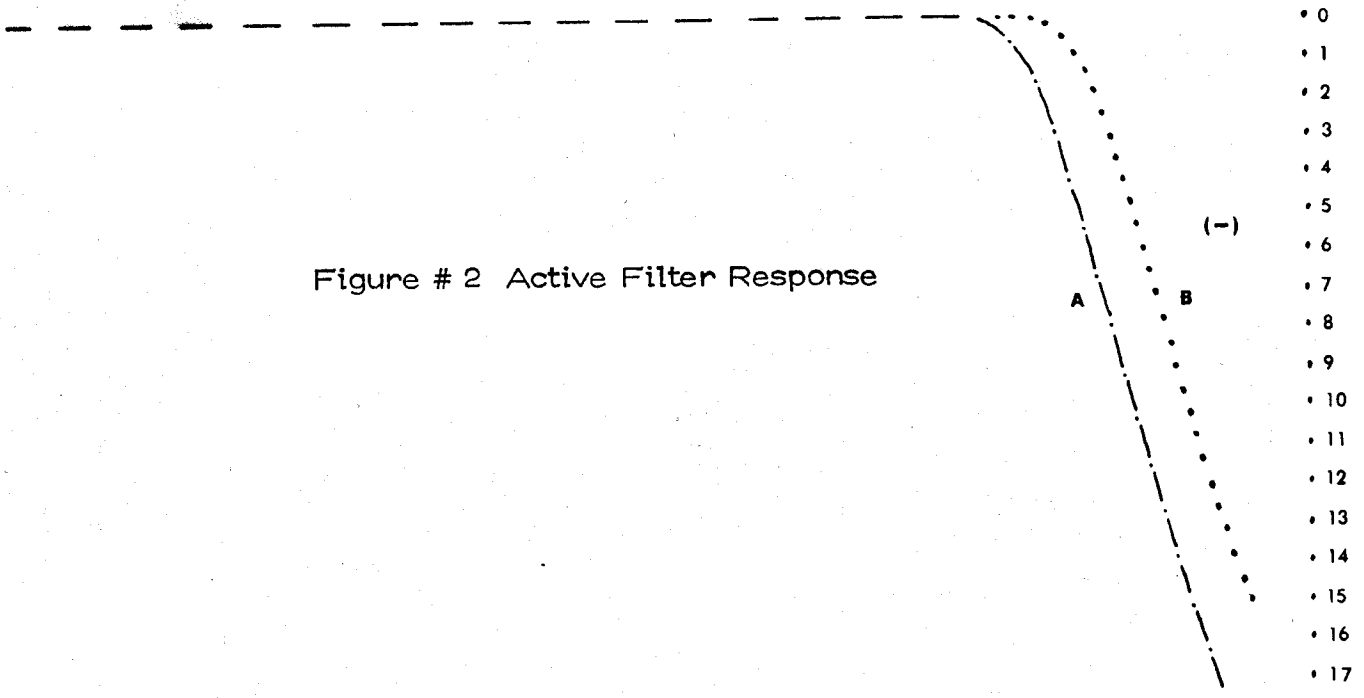

Figure # 1 Schematic Diagram - Stereo Generator



ASSEMBLY INSTRUCTIONS (See assembly drawing)

Use only a 25 watt pencil type soldering iron, and a good grade of 60/40 resin core solder. You can use as large as a 40 watt iron only if you are experienced in soldering. Use a small diameter solder since the pads are quite close and very small.

Start by installing all of the 1/4 watt resistors. Bend the leads over with your fingers and insert the leads into the appropriate holes. On the foil side bend the leads over flat against the board. The resistors should be flat against the top of the board. With diagonal cutting pliers cut off the excess lead length which extends past the edge of the solder pad. The resistors are now held in position - you can solder now or later. R53 will be soldered to bottom of board later.

Next install the trimmer potentiometers. Insert the leads of each into their holes and turn the board over. Hold it flat against the table so the trimmer pots are flat against the pc board. Solder each of the leads. Cut off excess lead length.

Look closely at IC's V and W. Note they have a half-moon at one end and a small dot at one edge. That dot indicates pin # 1. Your IC sockets should be marked in some way to show the corresponding end. It may have a slot, a short end bar, etc. When it is installed in the board it should face the direction of the half moon and dot. The reason for all this explanation is that you must remove pins 6 and 9 of the IC sockets used for IC's V and W. Pins are counted from the top. In the assembly drawing pin #1 is on the upper left. Count down the left side to pin 6 and remove it from the socket. End pin is 7 cross over to pin 8 and count up the right side (pin 9 is the second pin up from the right lower end).

Install all the IC sockets taking care they point in the right direction. Turn the board over and lay it flat on the table so the IC sockets are pressed firmly against the board. Solder at least one pin at each end of each socket to hold it in place. You can solder the rest of the pins now or later.

Now come the capacitors. The Tantalum and electrolytic caps have polarity marks. These must be installed with the polarity shown in the assembly drawing. Keep all capacitors close to the board and the leads short. Bend them over on the foil side to hold them in place. Cut off excess lead length that extends past the solder pad. Solder now or later. Note: If mini disc ceramics are substituted for the .1 uF Tantalum you won't need to worry about their polarity.

Bend the leads of the voltage regulator, IC T, to fit the hole placement on the board. Use a 4-40 x 1/4" machine screw and nut to fasten the tab to the board. Also install the diode (D1) at this time. Watch the polarity marking - a band at one end. The band goes toward C27. Bend over its leads on the foil side and cut off excess.

Whatever components you have not solder up to now should now be soldered. Look over your work carefully and inspect for solder bridges and bad solder joints. All points should be soldered except the crystal holes and where wires connect.



## STEREO GENERATOR, Cont'd.

You can now install all the wires. Use red or orange for + 12 volts, blue for the -12 volts, black for ground.

Use yellow for the right channel input, green for the left, black for ground.

If you elect to use the 10K input resistors R5 and R34 (+10 dBm input level required) then your audio inputs are at the points marked "L" and "R".

If you elect to inject signals at R7 and R35 (-10 dBm input level) then connect your input wires at the points indicated by the arrows.

Use a white wire for the output. Solder all wires.

Turn the board over and locate the spot indicated in the drawing on the right. Carefully solder one end of R53 to one of the points shown. keep the lead very short. Hold the resistor close to the board. Place the other lead next to the other connection point and cut off whatever lead length is not needed for soldering. Solder this other lead to the point indicated in the drawing.

Last of the soldering comin up. Install the crystal snug against the board. Bend over the leads on the foil side DO NOT CUT. Solder first, then cut.

Clean off the excess resin with alcohol and a stiff bristle brush, several times until it sparkles! Install the IC's in the directions shown in Fig. 4. Gently bend the leads inward if needed to more easily fit into the sockets.

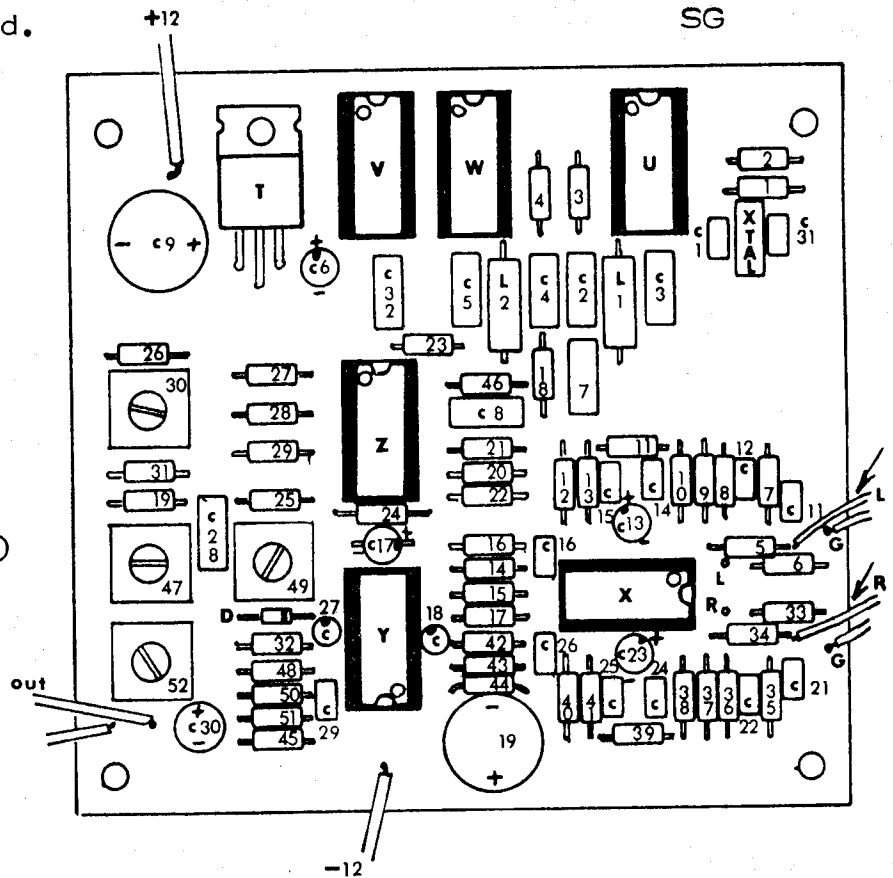

Figure # 4 Assembly Drawing

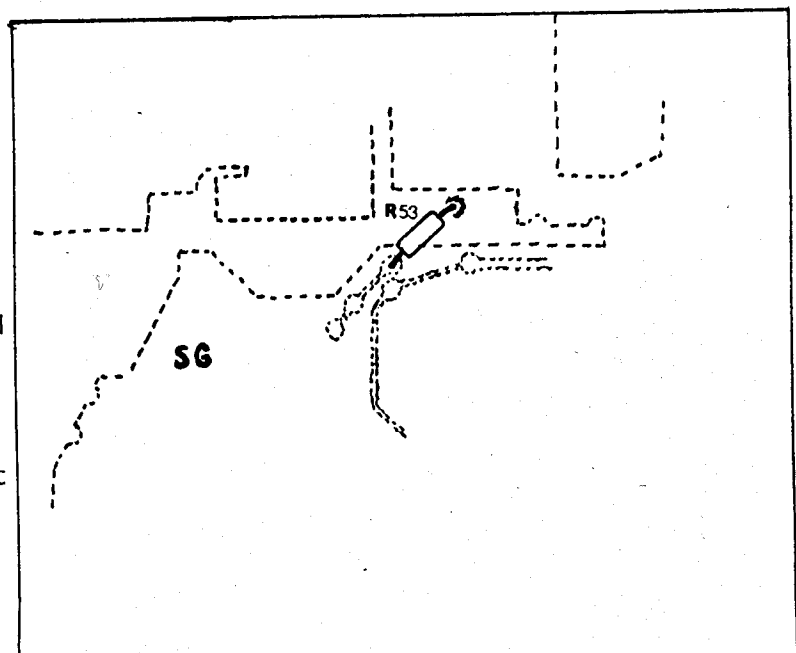

Figure # 5 R53 on foil side

TESTING AND ALIGNMENT

Set R49 to full counter-clockwise. Set R52 to full clockwise.

Connect your + 12 volts, - 12 volts, and ground but don't turn on the power supply yet. Turn on the supply only while you conduct tests. If tests don't seem to be working out as described turn off the supply and look for errors in component placement, solder bridges, bad joints, etc.

Connect the output to your measuring equipment. Connect an audio source to the input but do not apply audio yet.

Sub-carrier null

- (1) Connect an oscilloscope or very sensitive ac voltmeter, digital voltmeter, or sensitive dBm meter (-20 shown on scale), to the output. Set for the most sensitive range.
- (2) Turn on power supply. A scope should show square waves at some level, the meters should indicate some voltage which should be quite low. If you don't get this condition go back and check out things before proceeding.
- (3) Adjust R30 for minimum output. The scope pix should become a thin line, maybe a little fuzzy but as thin as possible. The meters should take a definite dip in voltage at the correct null point. An audio dBm meter should read close to -50 dB. This should occur with R30 at about mid position. This level is about .003 volts.

Stereo Separation

This adjustment is easily done with an oscilloscope. Simply connect a source of audio (sine wave) to either of the inputs, left or right. Connect the 'scope to the output.

Adjust R47 to obtain a flat base line as shown at right. Both of the other waveforms shown at the right represent poor separation.

After you have adjusted for a flat a line as possible connect your audio to the other input. Either input should produce close to the same waveform on the scope.

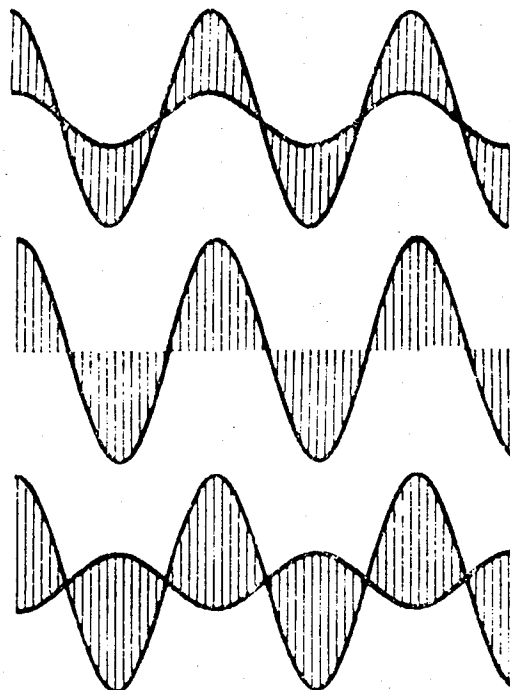

If you do not have a 'scope you'll have to do the stereo separation adjustment after the following pilot level adjustment and audio level adjustments.

### Audio Level Adjustment

Connect the composite stereo output of your SG to the broadband input of an FM exciter or oscillator. Set R49 to full counter-clockwise. Set R52 to full counter-clockwise (volume level of zero). Connect an audio signal to the left and right inputs.

Tune in your exciter or oscillator carrier on a good stereo receiver. This is just so you know where to come back to in just a moment. Now tune in a strong and well modulated station and set the receiver volume to a comfortable level.

Tune back to your carrier frequency. Adjust the SG composite output, R52, until the level of sound from your receiver is about as loud as the other station you checked previously. Tune back and forth between your signal and the other station to assure both audio levels are very nearly the same.

Your audio input should be at a level that you will normally be using. This should be about -20 to -10 dBm if wired direct to R7 and R35 inputs, greater if R5 and R34 are installed. If possible your audio input should be the SAME music or program material as the station you are checking against. This will make it much easier to match volume levels because the music content or whatever will be the same. We are assuming here that the station you are monitoring is modulating near 100%. The best way to set your 100% modulation level would be with an FM modulation monitor - an expensive instrument to have around.

### Pilot level adjustment

Once your audio level is set use a pencil to mark the position on R52, or make a note of the numbered position of the adjusting screw. Don't change the position.

Be sure the receiver is set for receiving stereo. Slowly adjust R49 until the stereo pilot light on the receiver comes on. This will be about 8 to 10% modulation. To assure adequate pilot increase the setting of R49 only a tiny amount so the pilot light is steady and without blinking or flickering. This should be 10 to 12% modulation. You only want to assure that the pilot frequency of 19 kHz will be received ok by all receivers that may tune it in. Try some other radios also. Use only as much pilot as it takes to keep the receiver's pilot light steady.

You are now ready to transmit a stereo signal.

### Stereo Separation adjustment without a 'scope

Connect audio to left channel input only. You should hear your audio coming from the left speaker of the receiver. You may also hear some coming from the right speaker. Move the receiver's balance control to full right. Adjust R47 for minimum right channel audio. Check left again (balance control to left) and then right again. Recheck adjustment for minimum right. Return balance to center position. Disconnect left audio input and connect right audio input, to check separation... do not readjust control R47.

This completes the SG alignment.

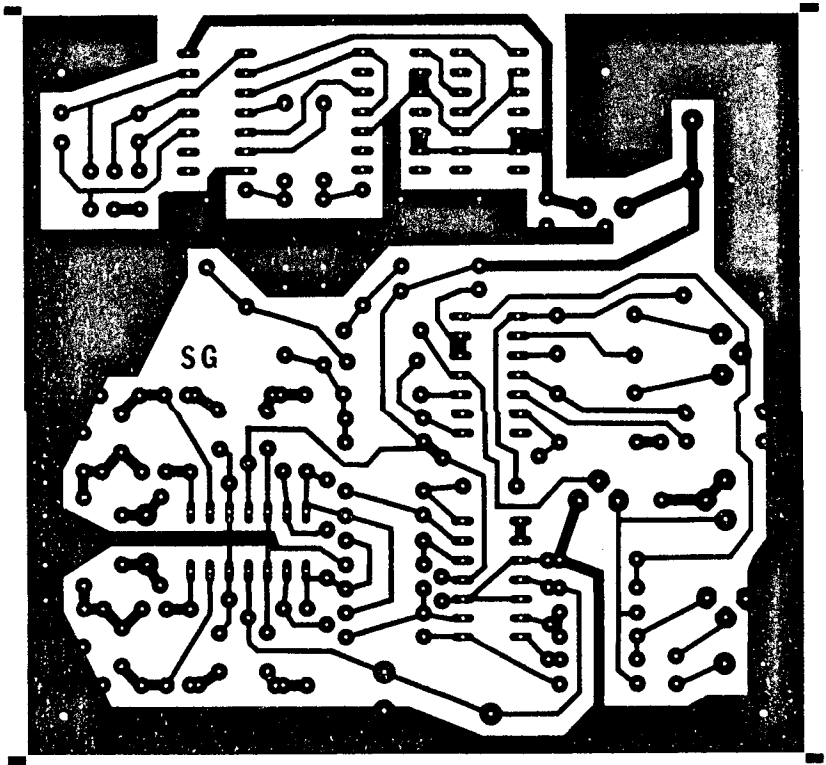

Figure # 7 PC Layout-full size