

Film-Tech

The information contained in this Adobe Acrobat pdf file is provided at your own risk and good judgment.

These manuals are designed to facilitate the exchange of information related to cinema projection and film handling, with no warranties nor obligations from the authors, for qualified field service engineers.

If you are not a qualified technician, please make no adjustments to anything you may read about in these Adobe manual downloads.

www.film-tech.com

Price \$10.00

D113198G

OPERATING INSTRUCTIONS

FOR

XH-16S AND XH-30S LAMPHOUSE

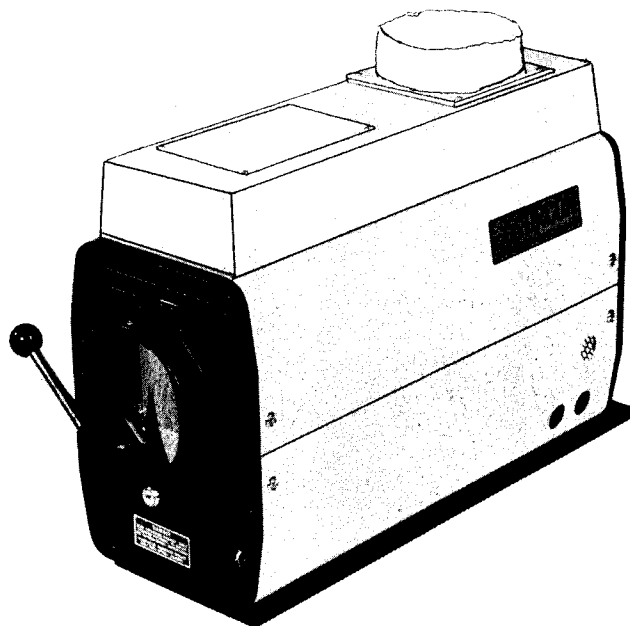

Optical Radiation Corporation

1300 Optical Drive, Azusa, CA 91702 • (213) 969-3344 • TWX 910-584-4851

REVISED JULY 1981

TABLE OF CONTENTS

<u>SECTION</u>		<u>PAGE</u>
1	INTRODUCTION	
1.1	Scope	1-1
1.2	General Description	1-1
1.3	Optical System	1-1
1.4	Xenon Bulb	1-2
1.5	Reflector	1-2
1.6	Douser	1-2
1.7	Dichroic Filter	1-2
1.8	Mounting Plate (optional)	1-3
1.9	Blower Time Delay Circuit (optional)	1-3
1.10	Lamphouse Controls & Interlocks	1-3
1.11	Lamphouse Specifications (table)	1-4
1.12	Interconnecting Cables (optional)	1-4
1.13	Remote Douser (optional)	1-6
2	IMPORTANT SAFEGUARDS	
2.1	Warning (defined).	2-1
2.2	Caution (defined).	2-1
2.3	Note (defined)	2-1
2.4	Safety	2-1
3	INSTALLATION	
3.1	Receiving - Handling	3-1
3.2	Installation Hardware (table).	3-1
3.3	Removal of Lamphouse From Container	3-1
3.4	Installation of Lamphouse to Mounting Plate.	3-1
3.5	Lamphouse Installation - Mechanical	3-2
3.6	Electrical Connection - Contactor Controls	3-3
3.7	Control AC Power to Lamphouse	3-5
3.8	Automation	3-7

TABLE OF CONTENTS - (CONT'D)

<u>SECTION</u>	<u>PAGE</u>
3.9	Optional Remote Douser 3-7
3.10	DC Power Cables/Lamphouse 3-8
3.11	Exhaust Duct 3-9
3.12	Installation of Dichroic Filters 3-10
3.13	Initial Bulb Installation 3-11 (XL-1000W & XL-1600W)
3.14	Initial Bulb Installation 3-17 (XL-2000W & XL-2500W)
4 OPERATION	
4.1	General 4-1
4.2	Lamphouse 4-1
4.3	Control Panel Assembly 4-1
4.4	Power On Switch 4-1
4.5	Manual Start Switch 4-1
4.6	Power Indicator Light 4-2
4.7	Air Flow/Interlock Light 4-2
4.8	Circuit Breaker CB-1 4-2
4.9	Circuit Breaker CB-2 4-2
4.10	Voltage Test Jacks 4-2
4.11	Bulb Current Meter 4-2
4.12	Elapsed Time Indicator 4-2
4.13	Vertical Focus Adjustment 4-3
4.14	Horizontal Focus Adjustment 4-3
4.15	Axial Focus Adjustment 4-3
4.16	Initial System Start Up 4-4
4.17	Start Up Procedure - Aligned System 4-5
4.18	Manual System Shut Down 4-6
5 OPTICAL ALIGNMENT	
5.1	General 5-1
5.2	Initial Set Up 5-1

TABLE OF CONTENTS - (CONT'D)

<u>SECTION</u>		<u>PAGE</u>
5.3	Initial Optical Alignment Procedure	5-2
5.4	Optical Re-Alignment	5-6
6	MAINTENANCE	
6.1	Cleaning Optics	6-1
6.2	Removal and Replacement of Bulb (XL-1000W and XL-1600W)	6-1
6.3	Removal and Replacement of Bulb (XL-2000W and XL-2500W)	6-5
6.4	Troubleshooting	6-8
7	BULB WARRANTY	
8	LAMPHOUSE DATA/ASSEMBLIES	

LIST OF ILLUSTRATIONS/DRAWINGS

<u>FIGURE/DWG NO</u>		<u>PAGE</u>
1-1	Lamphouse	1-5
3-2	Electrical Connection - Contactor Controls .	3-3
3-3	Installation of Lamphouse	3-4
3-4	Control AC Power to Lamphouse	3-5
3-5	DC Power Cables to Lamphouse	3-7
3-6	Inside XH-16S	3-10
3-7	Inside XH-30S	3-12
3-8	XH-30S Support Assembly	3-13
4-1	Control Panel	4-3
5-1	Projector/Lamphouse Alignment Location . . .	5-1
5-2	Alignment Procedure	5-3
1145038	Schematic Diagram	6-9
1136545	Wiring Diagram - Component Plate	6-10
1136546	Wiring Diagram - Mounting Plate	6-11
1136547	Wiring Diagram - Rear Bulkhead	6-12
1137128	Wiring Diagram - Additional - Optional . . . Remote Douser	6-13
1133494	Lens Kit	8-2
1145098	Final Assembly	8-3
1153377	Front Bulkhead Assembly	8-4
1145043	Center Bulkhead Assembly	8-5
1145000	Igniter Assembly	8-6
1145031	Component Plate Assembly	8-7
1145093	Rear Bulkhead Assembly	8-8
1135205	Control Panel Assembly	8-9
D113198	iv	6/77

SECTION 1 - INTRODUCTION

1.1 SCOPE

Provided in this manual are installation, operation and maintenance instructions for the Model XH-16S and XH-30S Orcon Xenon Lamphouses. These systems are manufactured by Optical Radiation Corporation (ORC), Azusa, California U.S.A. When requesting information, always furnish model and serial numbers.

1.2 GENERAL DESCRIPTION

The Model XH-16S and XH-30S Xenon Projection Lamphouses are designed for use with various external power supplies.

The XH-16S system, when used with a 1600 Watt xenon bulb, has an output of 20,000 lumens at a nominal current of 65 amperes (when using a f/1.7 projection lens). The XH-30S lamphouse used with a 2500 Watt xenon bulb, has an output of 30,000 lumens at a maximum current of 90 amperes. When properly aligned, a screen brightness distribution of not less than 75 percent is assured.

The basic lamphouse as delivered is set up for 35mm projection operation. An optional adapter is available for 70mm projection. An eight-inch optical centerline is standard. The optional lamphouse mounting plate adapts the lamphouse to a nine-inch optical centerline and allows direct mounting to most projector pedestals.

1.3 OPTICAL SYSTEM

The optical system includes a xenon bulb mounted horizontally in a metal aspheric reflector. The reflector collects the

emitted light from the bulb and reflects it through a dichroic filter to the projector's aperture. A manually operated douser is located inside the lamphouse just before the dichroic filter (see Figure 1-1).

1.4 XENON BULB
(XL1000W, XL1600W, XL2000W, XL2500W)

The xenon bulb is manufactured by Optical Radiation Corporation and is specifically designed for stable operation over a wide current range.

1.5 REFLECTOR

The reflector is a complex aspheric surface made of electroformed nickel and coated with aluminum. It is good for the life of the system and does not require replacement in the event of a bulb explosion.

1.6 DOUSER

The built-in douser is operated by a handle on the right side of the lamphouse (see Figure 1-1). The douser is provided to close off light to the projector while the xenon bulb is operating.

1.7 DICHROIC FILTER

The dichroic filter reduces film damaging infrared radiation from reaching the projector's aperture. The system is, therefore, capable of providing ample light to the screen without use of special aperture cooling techniques in standard applications.

1.8 MOUNTING PLATE (OPTIONAL)

For 35 or 70mm projection, it is recommended that an optional swivel mounting plate be used. This mounting plate attaches to the bottom of the lamphouse and adapts the lamphouse to the standard nine-inch optical centerline (see Figure 3-3).

1.9 BLOWER TIME DELAY CIRCUIT (OPTIONAL) (ORC P/N 1135087)

Once the system has been energized, the blower time delay circuit is activated. When the lamphouse is shut off and the bulb extinguished, the blower time delay circuit provides power to the lamphouse cooling blower for a period of time up to approximately five minutes, and then automatically de-energizes. The time of extended blower operation is dependent on the length of time the lamphouse was energized. This feature provides additional forced air cooling to the bulb after shut down.

1.10 LAMPHOUSE CONTROLS AND INTERLOCKS

The lamphouse controls are located on the rear panel (see Figure 1-1) for easy access. The system display lights consist of power on and interlock warning indications.

The controls are designed for manual or automated use with the various power supplies.

Two circuit breakers on the control panel provide circuit overload protection. A 0.5 amp breaker protects the igniter circuit and a 5 amp breaker protects the blower and control circuits.

The cover interlock switch prevents operation of the lamphouse if the top wrap is removed. The snout interlock prevents

operation of the lamphouse if the key lock front snout is not secured.

The air flow interlock switch prevents operation if the cooling blower fails.

1.11 LAMPHOUSE SPECIFICATIONS

BULB	DC CURRENT (AMPERES)	LUMEN OUTPUT*	POWER (WATTS)	FIELD UNIFORMITY
XL1000W	50	14,000	1000	
XL1600W	65	19,000	1600	
XL2000W**	85	24,000	2000	75% min.
XL2500W**	90	30,000	2500	

* OPEN APERTURE, f/1.7 PROJECTION LENS

** USED IN XH-30S LAMPHOUSE ONLY

1.12 INTERCONNECTING CABLES

Pre-cut interconnecting cables are available to allow connection of all wiring between the lamphouse and power supply. Cable assembly 1136557-5 consists of two D.C. cables and a power cord for hook-up of the high current lamp connections and power supply contactor controls (see sections 3.6 and 3.9) in the XH-16S lamphouse. Assembly 1136557-3 is for use with the XH-30S lamphouse. Standard cable length is eight feet with longer lengths optionally available.

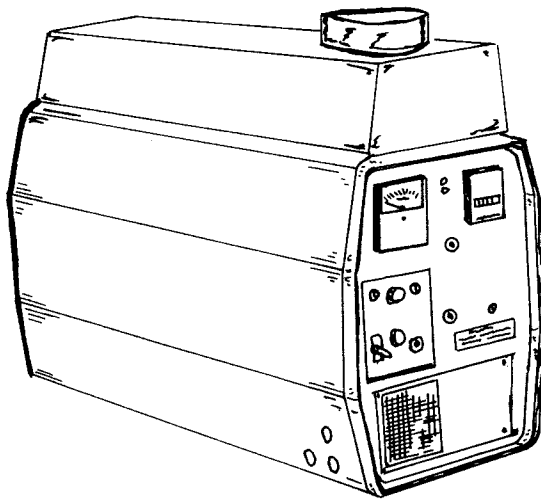
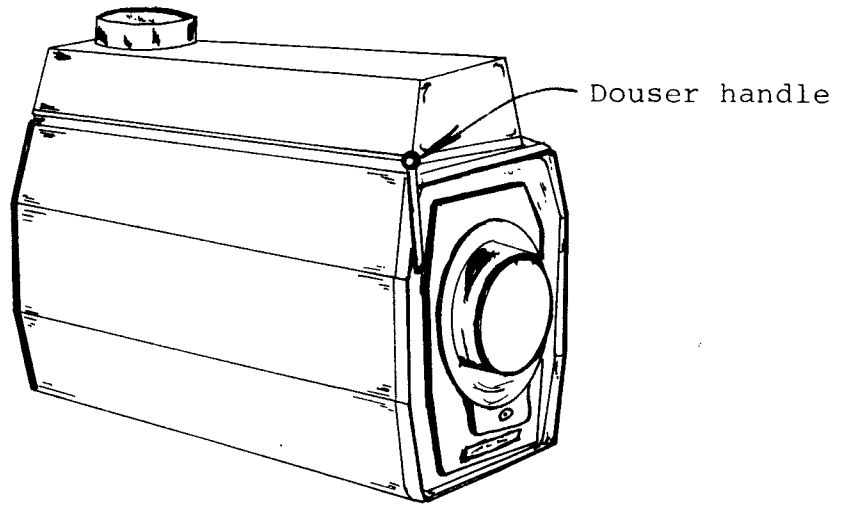

Figure 1-1 Lamphouse

1.13 REMOTE DOUSER (OPTIONAL)

A solenoid actuated remote controlled shutter (douser) is available as an option on the XH-16S lamphouse in place of the hand operated douser described in paragraph 1.6. The shutter is open when de-energized and is closed by closing a 115VAC signal at the appropriate terminals in the lamphouse.

- READ AND UNDERSTAND ALL INSTRUCTIONS -

2.1

WARNING

The above "WARNING" when appearing in this manual means: INSTALLATION, OPERATING AND MAINTENANCE PROCEDURES, PRACTICES, ETC., WHICH MAY RESULT IN PERSONAL INJURY OR LOSS OF LIFE IF NOT CAREFULLY FOLLOWED.

2.2

CAUTION

The above "CAUTION" when appearing in this manual means: INSTALLATION, OPERATING AND MAINTENANCE PROCEDURES, PRACTICES, ETC., WHICH MAY RESULT IN DAMAGE TO EQUIPMENT IF NOT CAREFULLY FOLLOWED.

2.3

NOTE

The above "NOTE" when appearing in this manual means: INSTALLATION, OPERATING AND MAINTENANCE PROCEDURES, PRACTICES, ETC., WHICH ARE ESSENTIAL TO EMPHASIZE.

2.4

SAFETY

2.4.1 Before attempting to make any connections or service to the system, make certain all power is disconnected from main power line.

2.4.2 Care must be taken as burns can occur from touching hot parts. Before servicing, wait at least 10 minutes for system to cool down.

2.4.3 Always disconnect all power from the system when not in use.

2.4.4 When taking any voltage measurements, caution should be exercised. Always avoid contact between any current carrying part of the system or power source and the human body.

2.4.5 When it is necessary to be exposed to or handle the xenon bulb, follow the necessary precautions outlined below.

WARNING

The xenon bulb is under extreme pressure and subject to possible explosion.

Do not view unenclosed bulb unless protective face mask is worn.

Bulb should never be handled outside its protective container or covering unless protective clothing consisting of (see Figure 2-1):

1. A quilted ballistic nylon jacket covering the body from below the groin to the neck including the arms to the wrist;

ORC Part Number 1136349-3

2. A protective face shield extending below the neck area;

ORC Part Number 1136349-5, and

3. Vinyl coated, knit lined gloves;

ORC Part Number 1136349-7

is worn. The instructions regarding protective clothing are subject to change by any local or federal specifications which take precedence.

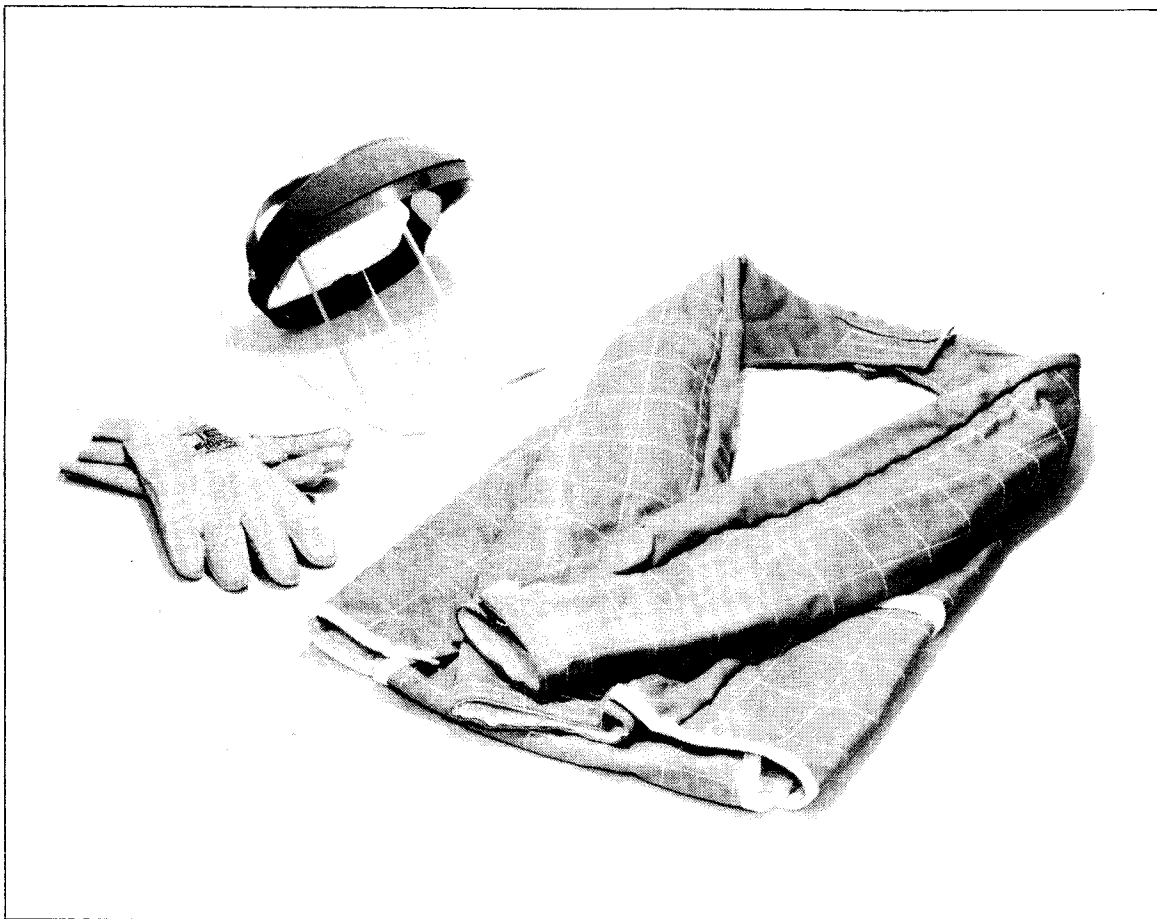

Figure 2-1

2.4.6 When installing the power source to the system, be certain that a ground wire is connected from the stud labeled "ground" and power source.

SAVE THESE INSTRUCTIONS

SECTION 3 - INSTALLATION

3.1 RECEIVING-HANDLING

Remove packing material from around the lamphouse and inspect for freight damage.

Any claims for damage or loss occurring in transit must be filed by the buyer with the carrier. Copies of the bill of lading and freight bill will be furnished on request.

Table 3-1 is a list of installation hardware included with each lamphouse.

3.2 INSTALLATION HARDWARE

Table 3-1

1 EACH	3/32 HEX KEY (SHORT ARM)	
1 EACH	3/16 PLAS-T-KEY	
1 EACH	9/64 HEX KEY (SHORT ARM)	
3 EACH	AIR FLOW TEST STRIPS (P/N 1126538)	
1 EACH	FACE MASK	} XH-30S LAMPHOUSE ONLY
1 PAIR	GLOVES	
1 EACH	1/8 HEX KEY (SHORT ARM)	
1 EACH	CATHODE ADAPTER (P/N 1121700-1)	} XH-16S ONLY

3.3 REMOVAL OF LAMPHOUSE FROM CONTAINER

Slit top of container along taped seam and remove lamphouse from container.

3.4 INSTALLATION OF LAMPHOUSE TO MOUNTING PLATE

The Orcon Mounting Plate (MP) should be used in all 35mm projector installations. The plate is designed to simplify

the initial installation and to provide speedy bulb replacement when required. Install the mounting plate and lamphouse on the projector pedestal as follows (see Figure 3-3):

- a. Remove two 1/4-20 x 3/4 LG flat head screws which secure plates together during shipment.
- b. Insert four 1/4-20 x 2" slotted flat head screws through lower base plate.
- c. Lay lower base plate on pedestal allowing screws to protrude into pedestal base.
- d. Install four 1/4" flat washers and four 1/4" lock washers onto bolts and secure with four 1/4-20 nuts. Nuts should be finger tight only so that lower base plate can be moved freely back and forth within the channels of the projector base.
- e. Normally, when ordered, the upper base plate is shipped installed to the lamphouse. If not installed, assemble the upper base plate to the bottom of the Orcon lamphouse using four 10-32 x 5/8" flat head screws, and tighten securely.
- f. Place the assembled lamphouse and upper base plate carefully onto the locating stud on the lower plate and temporarily insert the 5/16" x 3/8" Allen shoulder screw through the upper plate, into the threaded hole on the lower plate.
- g. After optical alignment has been accomplished (see Section 5-3), tighten all nuts securely.

NOTE

Once base plate is secured, it will not have to be readjusted during the life of the installation.

3.5 LAMPHOUSE INSTALLATION - MECHANICAL

The optional lamphouse mounting plate is designed to fit the

track of a standard 35/70mm projector pedestal (see Figure 3-3). The working distance from the aperture to the front bulkhead of the lamphouse is seven and one-half inches (see Figure 5-1).

When the lamphouse is used with a Norelco (or other non-standard) projector system, observe a working distance of seven and one-half inches and an optical centerline of nine inches. Special adapters are available from Optical Radiation Corporation to match non-standard projectors.

3.6 ELECTRICAL CONNECTION - CONTACTOR CONTROLS

Connect two 18 AWG (min.) wires from the power supply contactor to terminals four and five on TB-1 in lamphouse. (Use lower conduit hole on side of lamphouse.) See Figure 3-2.

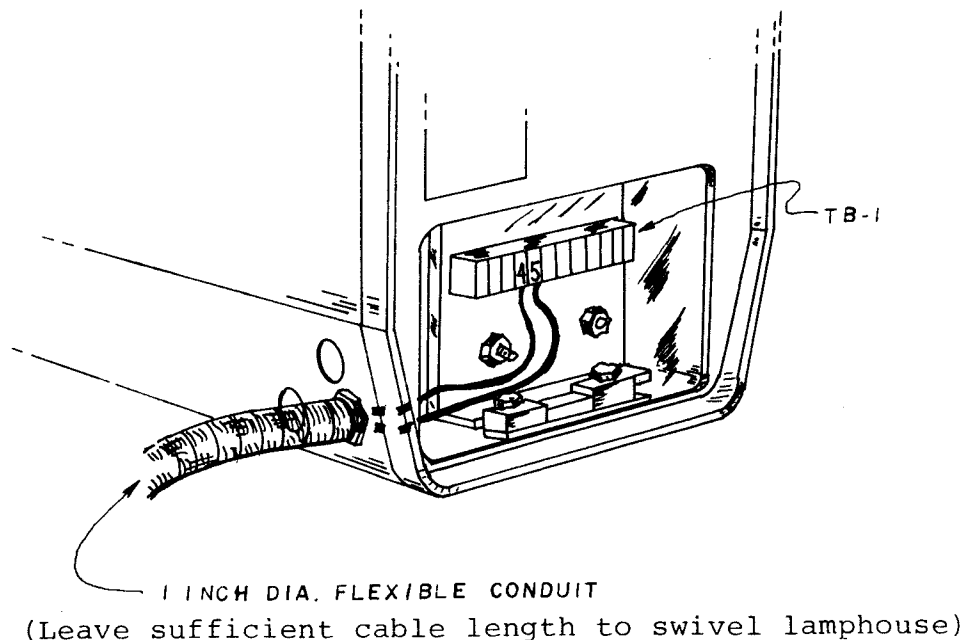

Figure 3-2

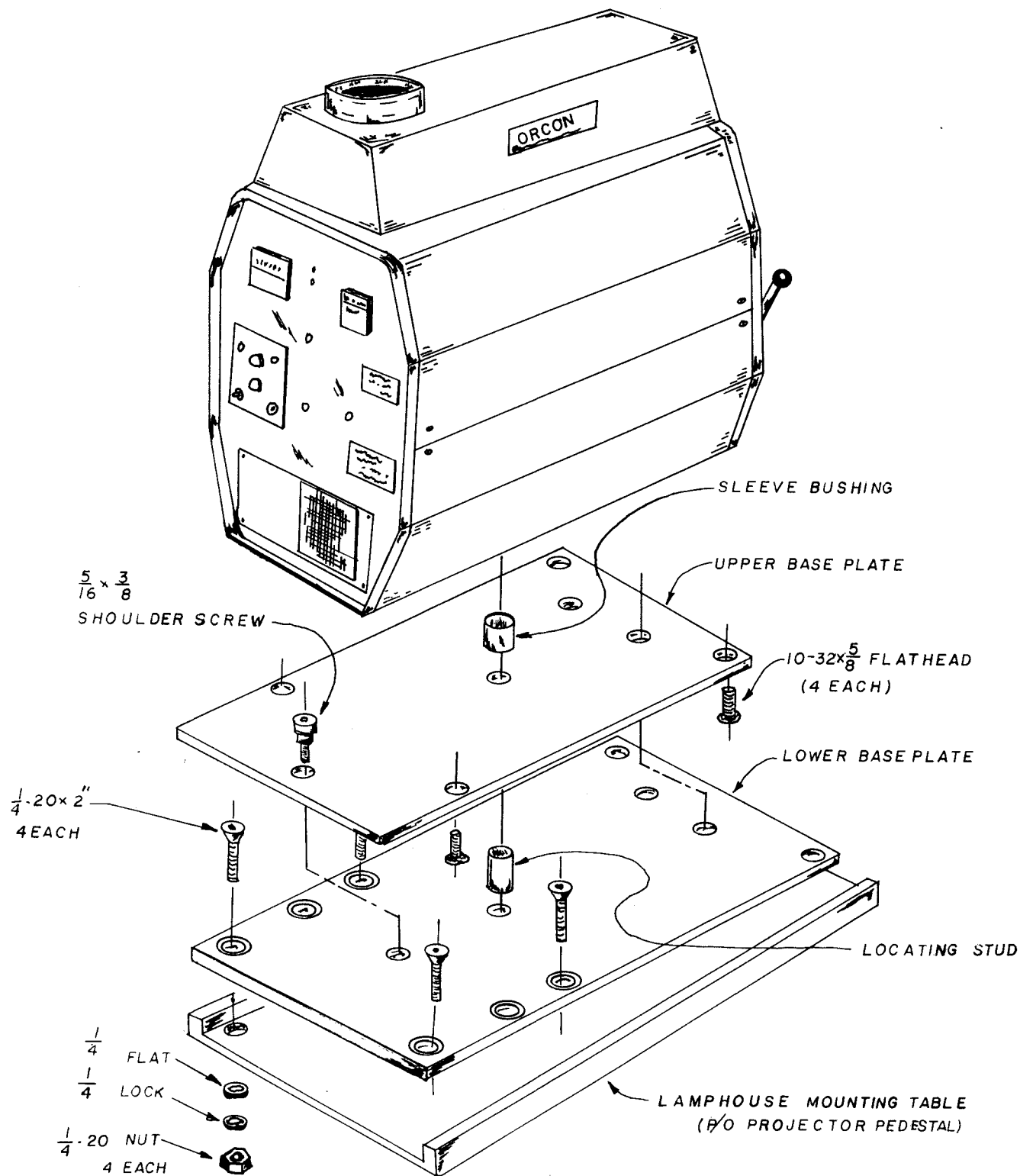

FIGURE 3-3

3.7 CONTROL AC POWER TO LAMPHOUSE

Connect 115 VAC power (No. 18 AWG wire min.) to terminals one and two of TB-1 (see Figure 3-4a). Route wires through conduit on side of lamphouse before making electrical connections.

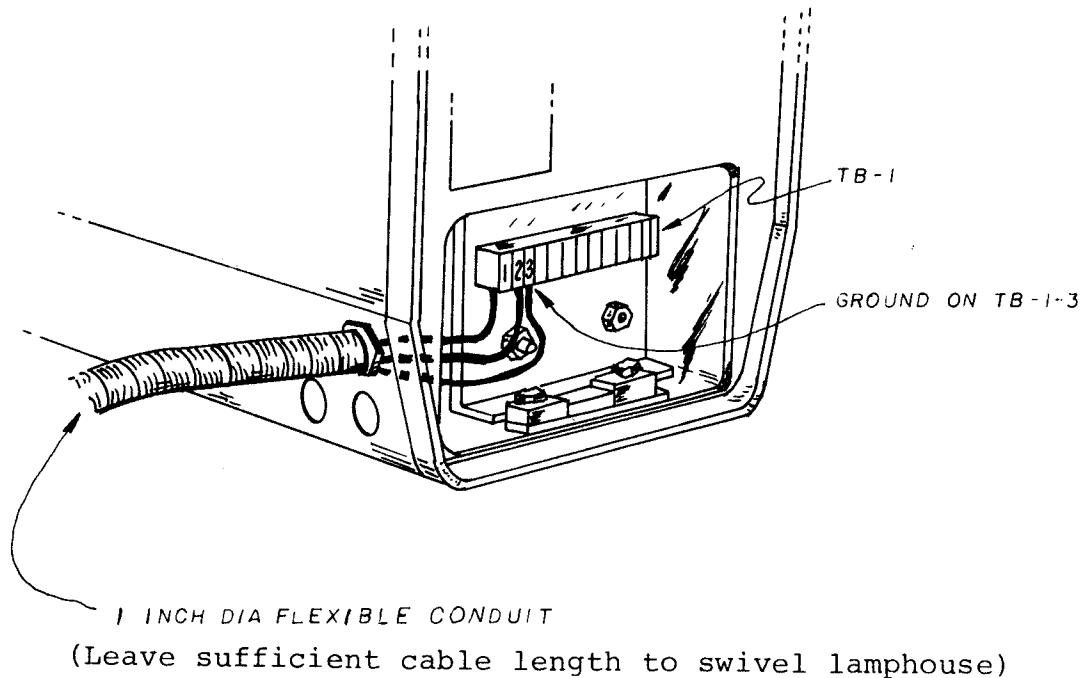

Figure 3-4a

NOTE

Some area safety codes may require that the 115 VAC power to the lamphouse be obtained from the same source as the power supply primary voltage. Two wiring arrangements noted below will comply with such a requirement.

3.7.1 NEUTRAL LINE

A 208/230 volt source with a neutral line from which 115 VAC is obtained is wired as shown in Figure 3.4b. Care must be taken to make sure primary source wiring has a true neutral (208 WYE) or tap (230 DELTA) line.

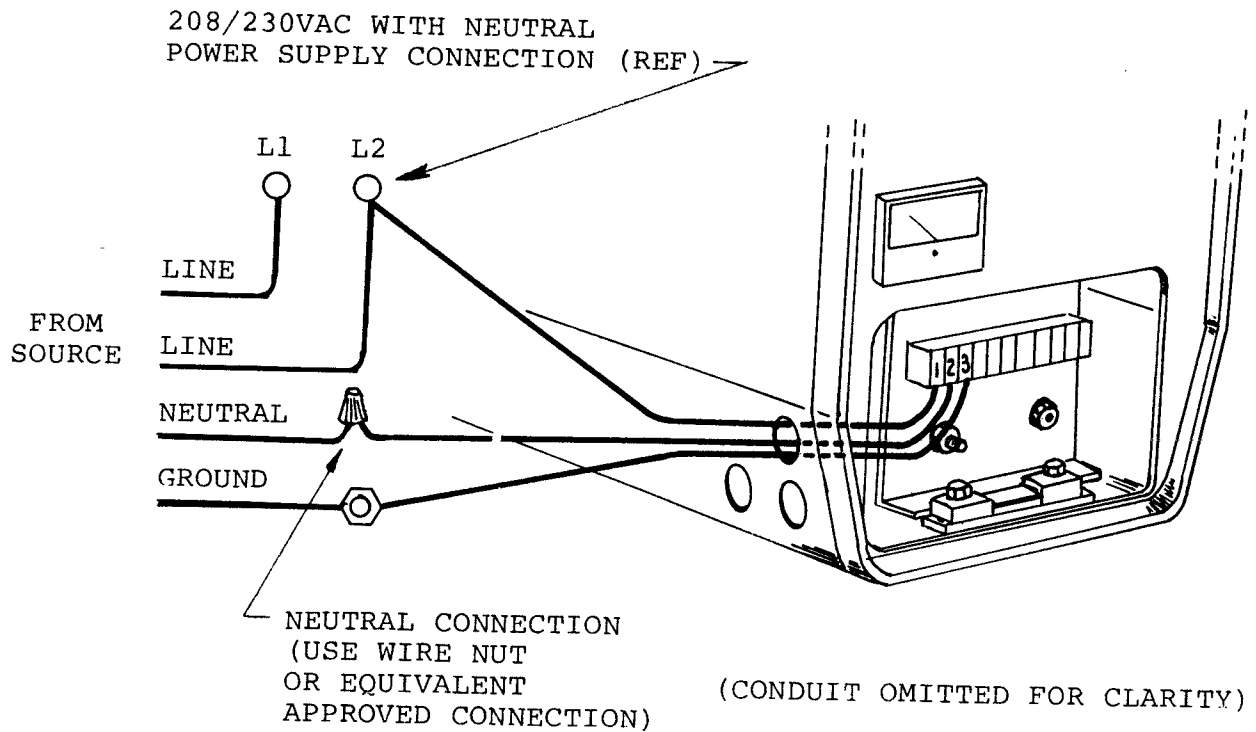

Figure 3-4b

3.7.2 ISOLATION TRANSFORMER

A 230 volt source without a neutral line requires an approved 208/230 VAC to 115 VAC step-down isolation line transformer with minimum capacity of 600 volt-amps at 60 Hz. See Figure 3-4c.

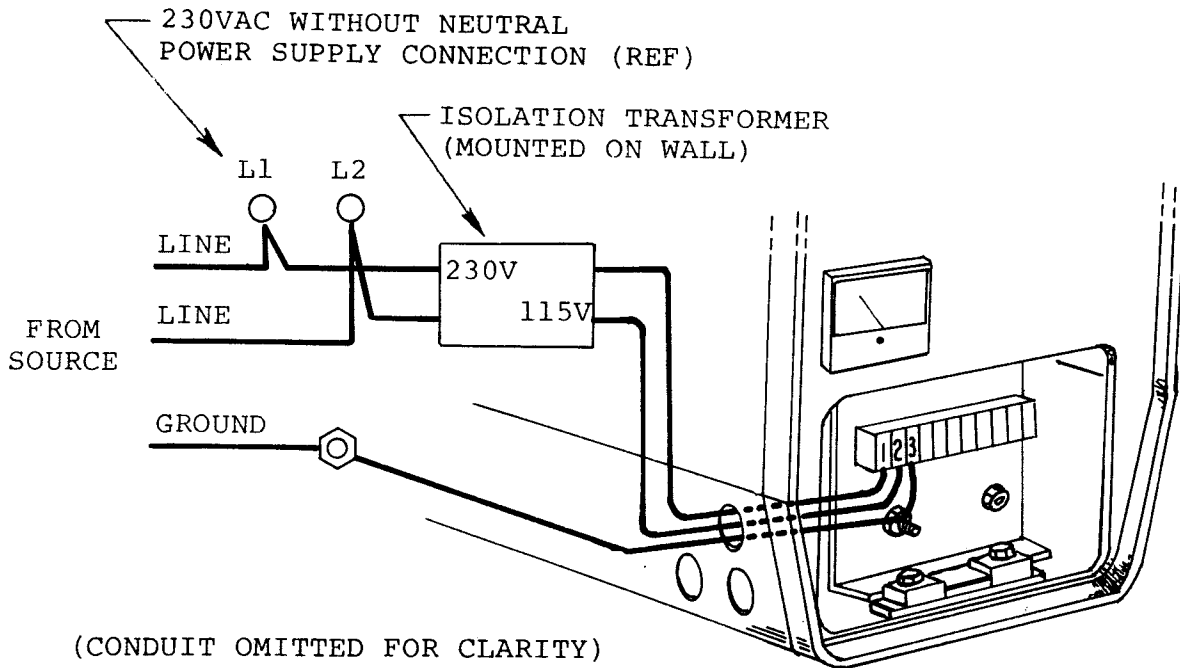

Figure 3-4c

3.8 AUTOMATION

Terminals six and seven of TB-1 in the lamphouse are provided for use with an external automation system. These terminals are wired directly across the lamphouse "POWER ON" switch. To control the lamphouse power-on function from a remote location, an isolated, sustained contact closure across TB1-6 and TB1-7 is necessary. Reference lamphouse schematic (Section 6). The automation control wires can be brought into the lamphouse through the lower access hole on the side of the lamphouse.

3.9 OPTIONAL REMOTE DOUSER

Terminals six and eight of TB-1 in the lamphouse are used for operation of the solenoid operated douser circuit when installed. The douser is open when de-energized. To close the douser from a remote location, an isolated, sustained contact closure across TB1-6 and TB1-8 is necessary. Reference optional douser circuit wiring diagram (Section 6).

3.10 DC POWER CABLES/LAMPHOUSE

Connect DC power to terminals shown in Figure 3-5. See power supply manual for power supply connections. Table 3-2 lists recommended power cable size.

CAUTION

Be sure correct polarity is observed or ignition will immediately destroy the bulb when power is applied.

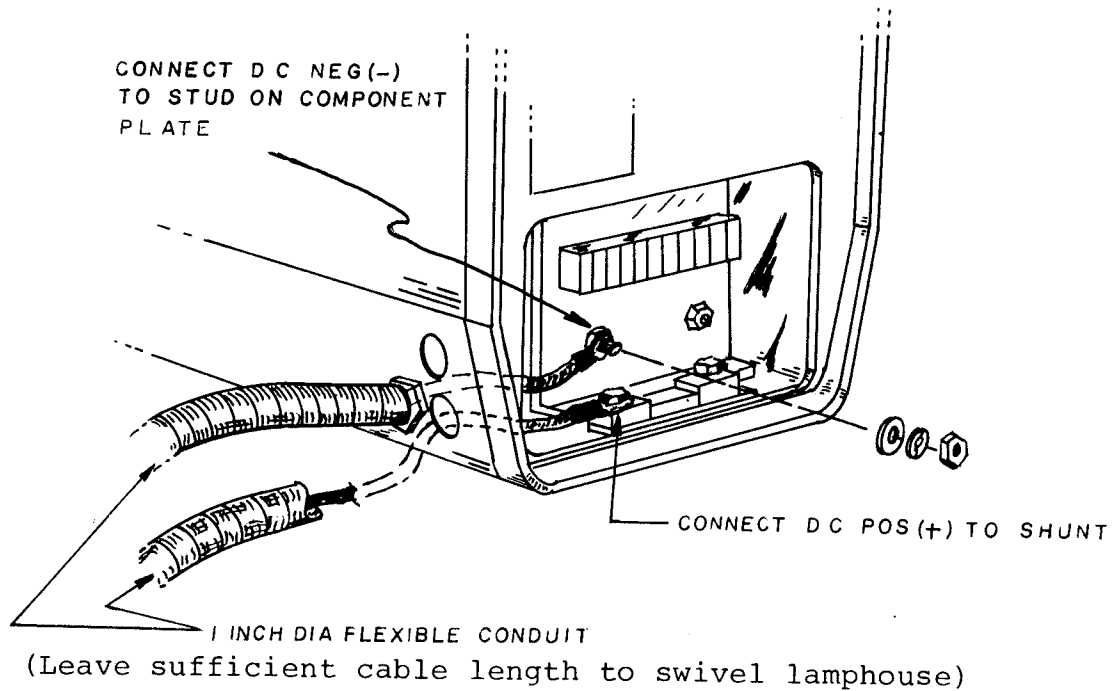

Figure 3-5

TABLE 3-2

LAMPHOUSE MODEL	MAXIMUM BULB CURRENT	RECOMMENDED WIRE SIZE DC CONNECTIONS
XH-16S	65 ADC	#4 AWG
XH-30S	90 ADC	#2 AWG

3.11 EXHAUST DUCT

It is recommended that the lamphouse be vented to a minimum six-inch diameter external exhaust duct. An external exhaust fan capable of 300 CFM minimum output is required for proper system cooling.

3.11.1 INSTRUCTIONS FOR EXHAUST FAN AIRFLOW TESTING

The ORC #1126538 test strips are calibrated for use with a 6-inch diameter air duct which is standard for all ORC lamphouses. By determining how many strips can be supported, the air flow can be determined over the range of 200-400 CFM (cubic feet per minute). To test the air flow, remove the exhaust duct and hold it horizontally about 6 inches above the lamphouse. (The lamphouse fan should be off.) Hold the strip(s) up to the duct as shown in Figure 3-6. Refer to Table 3-3 to determine the CFM and maximum lamphouse power versus the number of strips that can be supported by the air flow. Note that the strips are to be stacked, (They are not placed side by side.) and that it is not necessary to tape them together.

TABLE 3-3 AIR FLOW TEST

NUMBER OF STRIPS	AIRFLOW 6" DIAMETER	MAXIMUM LAMP POWER
1	200 CFM (100 LITERS PER SECOND)	1600 WATTS
2	300 CFM (150 LITERS PER SECOND)	3000 WATTS
3	400 CFM (200 LITERS PER SECOND)	4500 WATTS

CAUTION

It is mandatory that a minimum flow of 300 CFM in the XH-30S lamphouse and 200 CFM in the XH-16S lamphouse be provided after compensation for head pressure losses in the exhaust ducting.

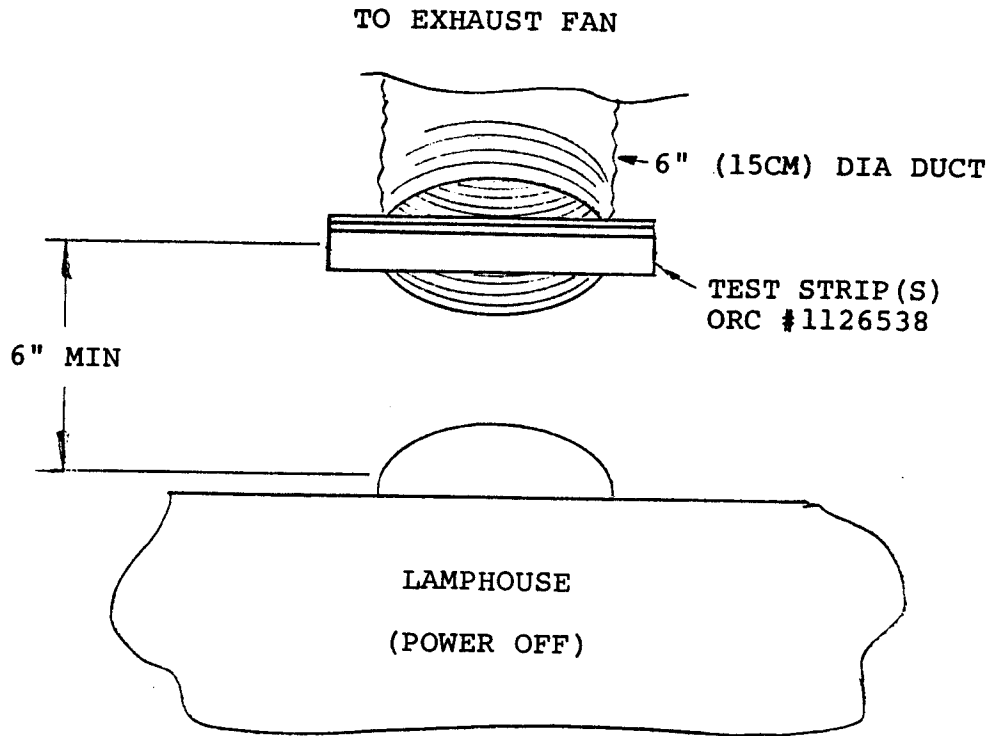

FIGURE 3-6
AIR FLOW TEST

3.12 INSTALLATION OF DICHROIC FILTERS
(SEE DRAWING 1133494-3, SEC. 8)

Installation of the dichroic filter should take place before the bulb is installed. This is accomplished as follows:

CAUTION

Wear white cotton or linen gloves whenever handling filter glass. Finger contact with glass surface will leave body oil marks which will impair performance and cause fracture of the glass as a result of heat spots caused by local absorption of the energy from the light source.

a. While holding filter glass at an angle in a bright light, observe for any unusual stains. If stains are noticed, clean with a mild hand soap and water or an ammonia base household cleaner in an aerosol can. Rinse well with cold water and dry with Kleenex or equivalent.

b. Use key to unlock front bulkhead. Swing up and open to a horizontal position.

c. Remove clips (Item 4) and screws (Item 5). Filter segments (Item 13) should be installed with coated side facing light source. A black mark is painted on the uncoated side of the filter and should face towards the projector when installed.

d. Slide both filters in place, install retainers (Item 6) and tighten retainer screws (Item 7).

e. Install clips (Item 4) and tighten clip screws (Item 5).

f. Close front bulkhead and secure with key.

3.13 INITIAL BULB INSTALLATION (XL1000W AND XL1600W BULBS) (SEE FIGURE 3-6 OR 3-7)

WARNING

The xenon bulb is under extreme pressure and subject to possible explosion. Do not apply lateral pressure against the bulb during installation. Do not view un-enclosed bulb unless protective face mask is worn. Bulb should never be handled outside its protective container or covering unless protective clothing consisting of gloves, face shield and jacket, as specified in Section 2 of this manual, is worn. The instructions regarding protective clothing are subject to change by any local or federal specifications which take precedence.

NOTE

XH-30S LAMPHOUSES TO BE USED
WITH XL-1000W OR XL-1600W XENON BULBS

The XH-30S lamphouse is shipped with anode connector, ORC P/N 1124915 , as standard equipment. This connector is for use with the higher power Orcon xenon bulbs, 2000 to 2500 Watts. If the system is intended for use with a lower power Orcon bulb, such as the XL-1000W or XL-1600W, an optional anode connector, ORC P/N 1134986-3, and optional cathode connector, P/N 1121700-1, are required to hold the smaller bulb securely between the swivel bearings in the XH-30S lamphouse.

- a. Swivel lamphouse away from projector to gain access through the front bulkhead door.
- b. Unlock the front bulkhead door with the key which has been attached to the douser handle for shipment. Release the safety catch and swing door upward to allow clearance for bulb installation.
- c. Remove upper wrap from lamphouse exposing focus tube assembly.
- d. Take the xenon bulb with its installation/-removal tool from the carton and remove the wing-nut, retaining bracket, and red plastic end cap from the threaded (cathode) end of the bulb.
- e. Find the cathode adapter, ORC P/N 1121700-1, included with the lamphouse hardware and thread it on to the cathode (-) fitting of the xenon bulb until snug.
- f. (XH-30S Lamphouse Only) Locate the wing-nut on the anode support assembly and loosen to allow removal of the support with anode connector, ORC P/N 1134986-3 and set support assembly off to one side (see Figure 3-8).

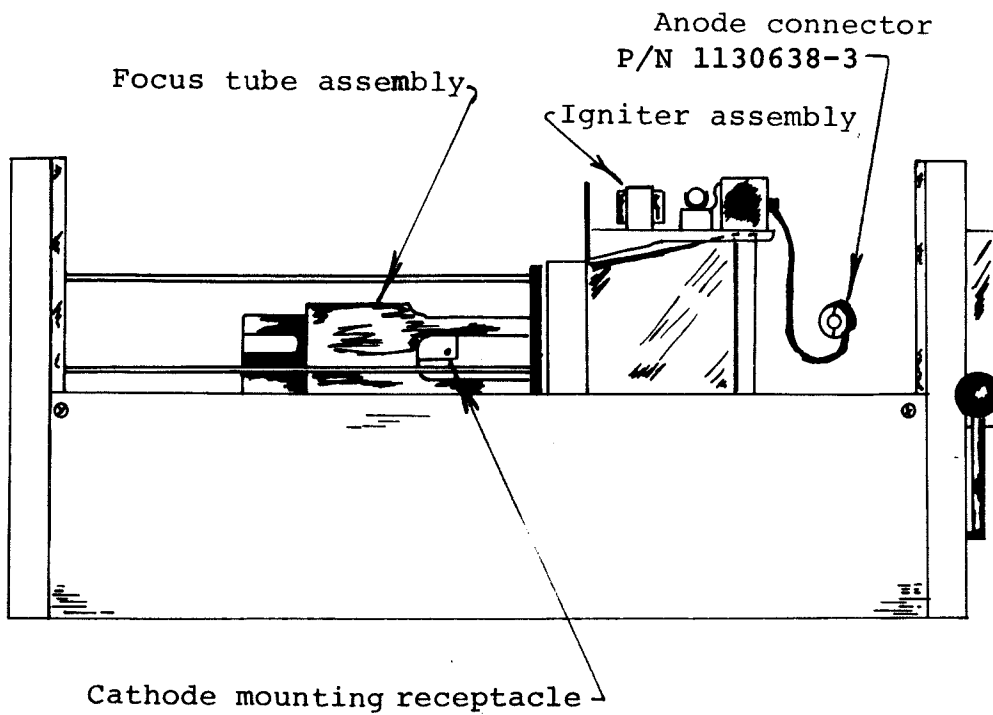

Figure 3-6. Inside Model XH-16S Lamphouse

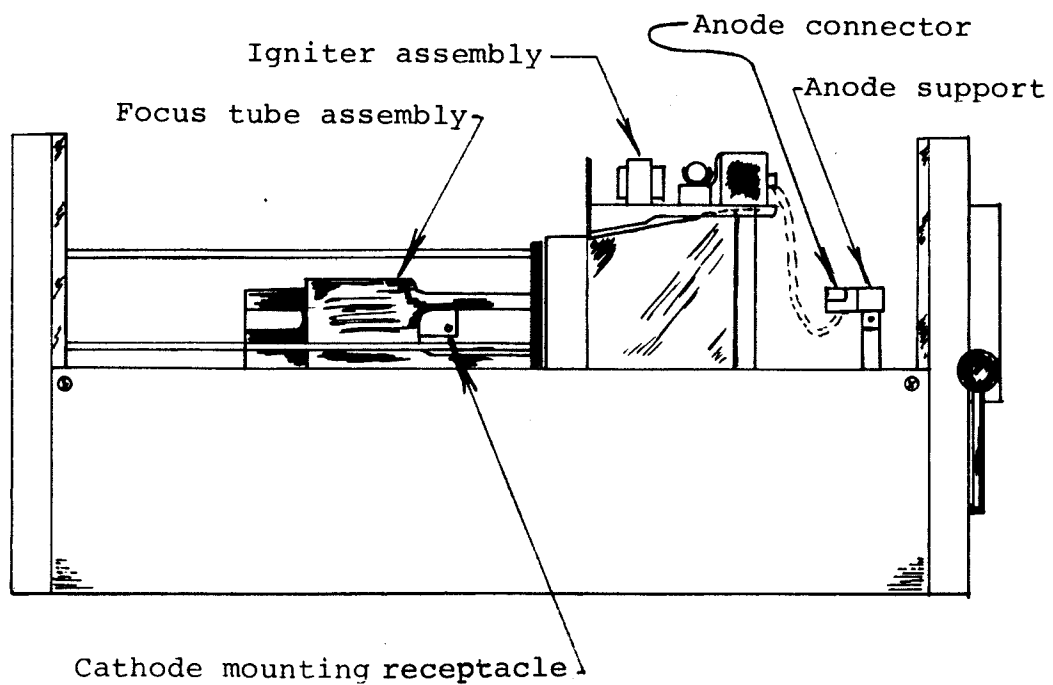

Figure 3-7. XH-30S Lamphouse

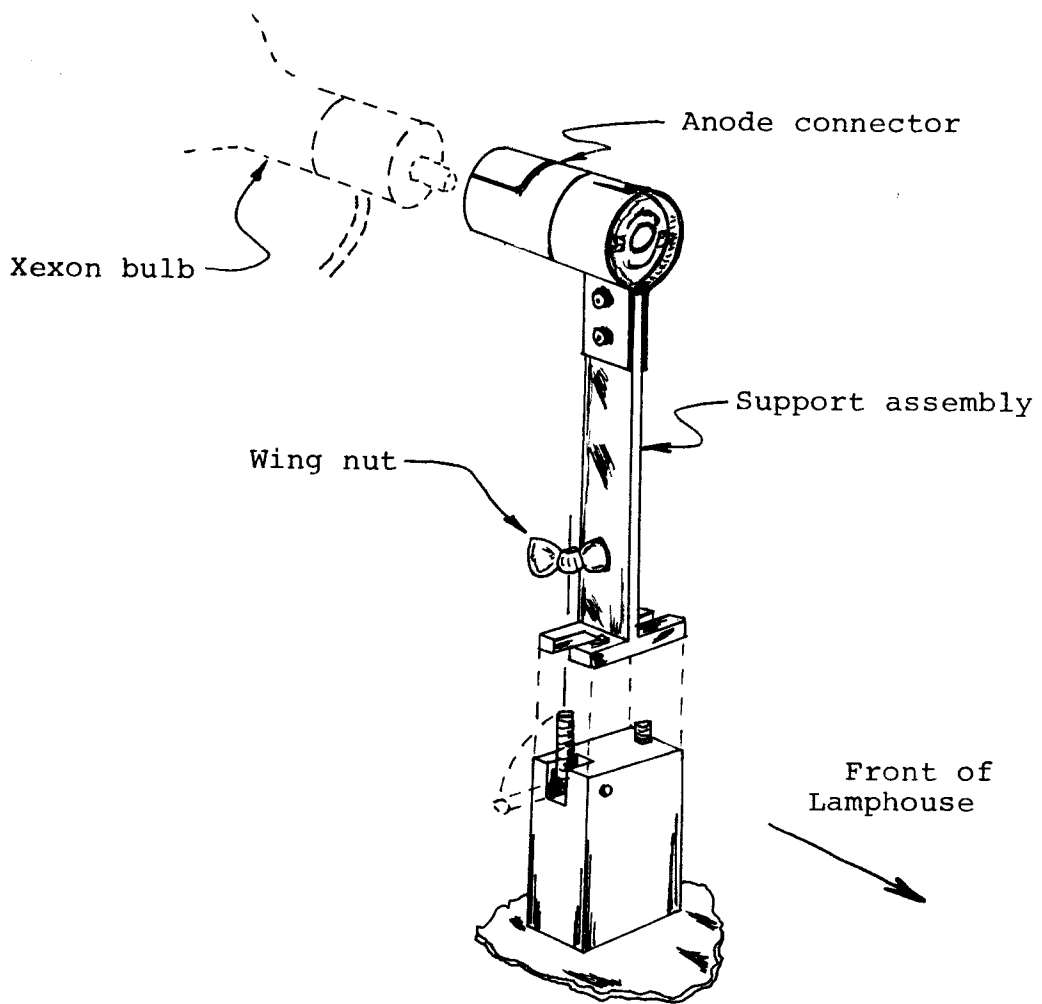

Figure 3-8

g. With the bulb still contained within the bulb installation/removal tool, insert the bulb, cathode end with adapter first, into the opening at the center of the reflector. Carefully feed the adapter stud into its mating receptacle behind the reflector until the adapter is seated against the mating surface. Tighten the two set screws in the receptacle.

h. Carefully remove the collar holding the bulb installation/removal tool to the anode (+) fitting of the bulb with a 1/8 inch hex wrench.

CAUTION

Do not touch quartz surface of bulb with bare hands. Finger contact with bulb surface will leave body oil marks which could result in fracture or explosion of the bulb during operation. If the bulb becomes contaminated, it should be cleaned with pure alcohol. Wear protective clothing.

i. Remove the bulb installation/removal tool from the bulb. Do not exert any bending pressure on the bulb.

j. (XH-30S Lamphouse Only) Replace anode support assembly with anode connector ORC P/N 1134986-3 and tighten the retaining wing-nut.

k. Place the anode connector over the anode stud of the bulb and carefully tighten the socket screws on the connector with a 9/64" hex wrench. Support the end of the bulb with one hand while tightening so that lateral pressure is not applied on the bulb.

CAUTION

Make sure front lead from igniter to bulb is not touching any part of mirror or high voltage arcing and shorting may occur.

l. Lower front bulkhead door into place and secure by locking and removing key. Replace and secure upper wrap.

m. Swivel lamphouse back into position for operation and optical alignment.

3.14 INITIAL BULB INSTALLATION

(MODEL XH-30S LAMPHOUSE ONLY, XL-2000W - XL2500W BULBS)
(SEE FIGURE 3-7)

WARNING

The xenon bulb is under extreme pressure and subject to possible explosion. Do not apply lateral pressure against the bulb during installation. Do not view un-enclosed bulb unless protective face mask is worn. Bulb should never be handled outside its protective container or covering unless protective clothing consisting of gloves, face shield and jacket, as specified in Section 2 of this manual, is worn. The instructions regarding protective clothing are subject to change by any local or federal specifications which take precedence.

a. Swivel lamphouse away from projector to gain access through the front bulkhead door.

b. Unlock the front bulkhead door with the key which has been attached to the douser handle for shipment. Swing door upward to allow clearance for bulb installation.

c. Remove upper wrap from lamphouse, exposing focus tube assembly.

d. Take the xenon bulb with its protective plastic wrap in place from the carton.

e. At installation, loosen end string ties on plastic wrap. Unwrap ends of plastic wrap preparing it for easy removal once bulb is installed.

f. Locate the wing-nut on the anode support assembly and loosen to allow removal of the support with anode connector ORC P/N 1124915 and set support assembly off to one side (see Figure 3-8).

g. Insert the bulb, cathode (-) end first, into the opening at the center of the reflector. Carefully feed the cathode stud into its mating receptacle behind the reflector until the bulb is seated against the mating surface.

h. Replace anode (+) support assembly with anode connector ORC P/N 1124915 and tighten the retaining wing-nut.

i. Make certain shoulder of bulb is flush with cathode mounting receptacle, then tighten two set screws in mounting receptacle.

j. Firmly tighten set screws on anode end of bulb.

k. Attach anode lead from bulb to high voltage terminal of the igniter transformer. Tighten screw securely but be careful not to shear stud of high voltage terminal by applying excessive pressure.

CAUTION

Do not touch quartz surface of bulb with bare hands. Finger contact with bulb surface will leave body oil marks which could result in fracture or explosion of the bulb during operation. If the bulb becomes contaminated, it should be cleaned with pure alcohol. Wear protective clothing.

l. Carefully remove the plastic wrap from the bulb without pulling or exerting any bending pressure on the bulb.

CAUTION

Make sure front lead from igniter to the bulb is not touching any part of mirror or high voltage arcing and shorting may occur.

- m. Lower front bulkhead door into place and secure by locking and removing key. Replace and secure upper wrap.
- n. Swivel lamphouse back into position for operation and optical alignment.

SECTION 4 - OPERATION

4.1 GENERAL

The following is a general description of the controls and displays on the lamphouse.

4.2 LAMPHOUSE (SEE FIGURE 1-1)

4.3 CONTROL PANEL ASSEMBLY (SEE FIGURE 4-1)

NOTE

The functions noted below apply when lamphouse is properly connected to a power supply and with all interlocks and circuit breakers closed.

4.4 POWER ON SWITCH

When the POWER ON switch is engaged, it does the following:

- a. Starts blower motor in lamphouse.
- b. When air flow switch closes, power supply contactor is energized.
- c. Bulb ignition will occur approximately 1-3 seconds after contactor closes (time required to reach open circuit voltage).

4.5 MANUAL START SWITCH

The MANUAL START switch is used as an emergency switch if the automatic ignition circuit fails to ignite the bulb.

CAUTION

Do not use the manual start switch unless necessary. When using the switch, depress for approximately one second. Prolonged closure decreases the life of the electrodes within the xenon bulb.

4.6 POWER INDICATOR LIGHT

The POWER INDICATOR LIGHT indicates power on.

4.7 AIR FLOW/INTERLOCK LIGHT

The AIR FLOW/INTERLOCK LIGHT indicates insufficient air flow, or open interlock switch.

4.8 CIRCUIT BREAKER (5 AMP) CB-1

CIRCUIT BREAKER (5 amp) protects against 115V input power overload.

4.9 CIRCUIT BREAKER (0.5 AMP) CB-2

CIRCUIT BREAKER (0.5 amp) protects ignitor circuit.

4.10 VOLTAGE TEST JACKS

The VOLTAGE TEST JACKS are for measurement of bulb voltage (DC).

4.11 BULB CURRENT METER

This meter indicates DC current to xenon bulb.

4.12 ELAPSED TIME INDICATOR

The ELAPSED TIME INDICATOR indicates the number of hours the system has been in operation. Its primary function is to determine bulb operation time as required on the Bulb Warranty Card. Refer to Section 7 for detailed instructions.

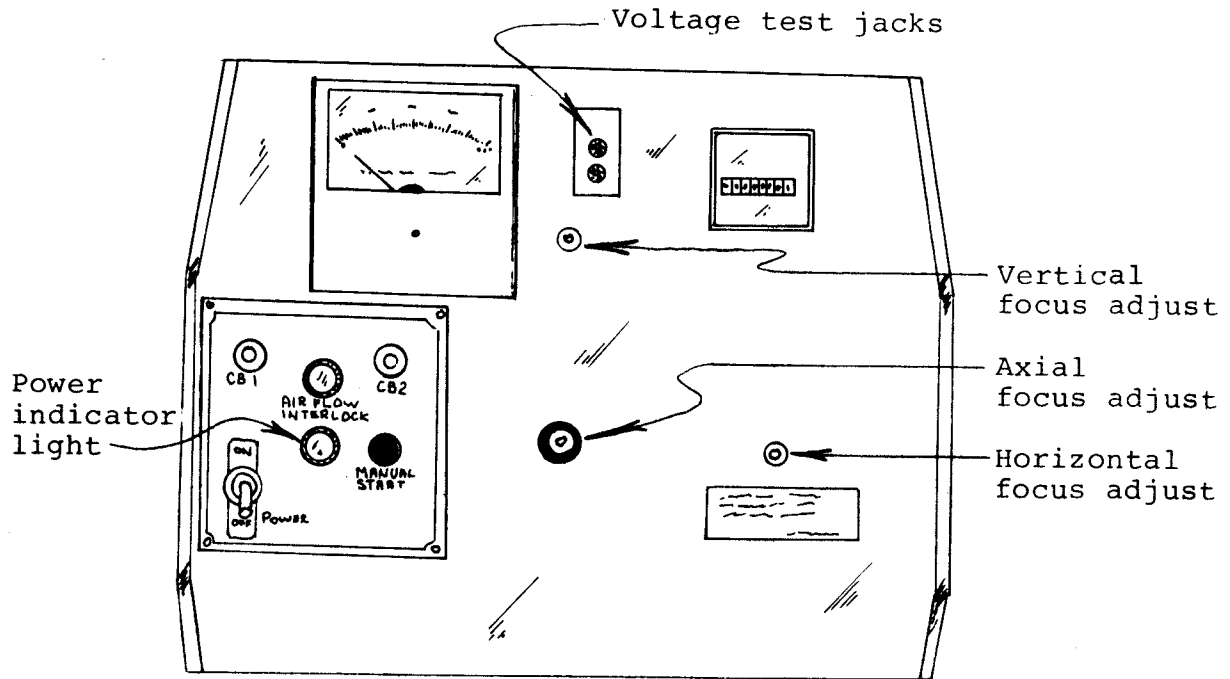

Figure 4-1. Control Panel

4.13 VERTICAL FOCUS ADJUSTMENT

This adjustment moves the beam image up or down in the vertical direction on the screen.

4.14 HORIZONTAL FOCUS ADJUSTMENT

This adjustment moves the beam image horizontally on the screen.

4.15 AXIAL (CENTER) FOCUS ADJUSTMENT

This adjustment moves the bulb along the optical axis, controlling the size of light image on the screen. See optical alignment section for details.

4.16 INITIAL SYSTEM START UP

Complete installation as outlined in Section 3. The following procedure describes the recommended method of initial system start up.

CAUTION

Make sure the external exhaust system is "ON" before igniting the xenon bulb.

- a. Set the current control taps on the power supply for the minimum output current. Refer to power supply manual for tap adjustment procedure.
- b. Turn off power-on switch in the control panel and apply primary power to the system.
- c. Close the lamphouse douser.
- d. Turn on the power supply circuit breaker. This applies power to the input terminals of the power supply contactor.
- e. Turn on the power switch on the control panel. The power-on indicator on the panel should light and the power supply should energize. Within three seconds, the xenon bulb should ignite.

CAUTION

If the bulb does not automatically ignite, activate the MANUAL START switch for approximately one second. If the bulb still fails to ignite, recheck the start-up procedure, or refer to the troubleshooting section of this manual.

If the bulb ignites (flashes) but does not remain lit, de-energize the power supply and set the current control taps to the next higher current position. Repeat the start-up procedure.

- f. Energize the projector.

4.17 START-UP PROCEDURE - ALIGNED SYSTEM

After the system has been installed and aligned, subsequent start-ups are simplified. The following steps are recommended:

- a. Apply primary power to the system.
- b. Close the lamphouse douser.
- c. Turn on the power supply circuit breaker. This applies power to the input terminals of the power supply contactor.
- d. Turn on the power switch on the control panel. The lamp-on indicator on the panel should light and the power supply should energize. Within three seconds, the xenon bulb should ignite.

CAUTION

If the bulb does not ignite automatically, activate the MANUAL START switch for approximately one second. If the bulb still fails to ignite, recheck the start up procedure, or refer to the troubleshooting section of this manual.

- e. Thread the projector.
- f. Close the change-over douser, energize the projector, open the lamphouse douser, and then open the change-over douser to project light on the screen.

CAUTION

Never open the lamphouse douser unless the projector is running. Damage to the shutter, film, and the projection lens could result. Do not allow the light beam to strike the change-over douser for more than 60 seconds at a time. Do not operate the xenon bulb for extended periods of time with the lamphouse douser closed, especially at higher power operation.

4.18 MANUAL SYSTEM SHUT DOWN

The following procedure is recommended:

- a. Close the lamphouse douser to protect the projector from damage after it is de-energized.
- b. Shut the projector motor off.
- c. De-energize the xenon bulb by switching the power switch off, and then open the RECTIFIER circuit breaker.
- d. If the optional blower time-delay circuit is included in the lamphouse wiring, the lamphouse cooling blower will continue to operate for approximately four minutes to provide additional cooling to the bulb after shut down.

WARNING

REMOVE ALL POWER FROM THE SYSTEM BEFORE SERVICING.

SECTION 5 - OPTICAL ALIGNMENT

5.1 GENERAL

Lamphouse must be aligned with the optical axis of the projector lens before alignment of the system can be accomplished.

5.2 INITIAL SET UP

Position lamphouse and projector film gate on approximately the same centerline $\pm 1/16$ inch (see Figure 5-1). Locate front of lamphouse approximately 7-1/2 inches from film gate.

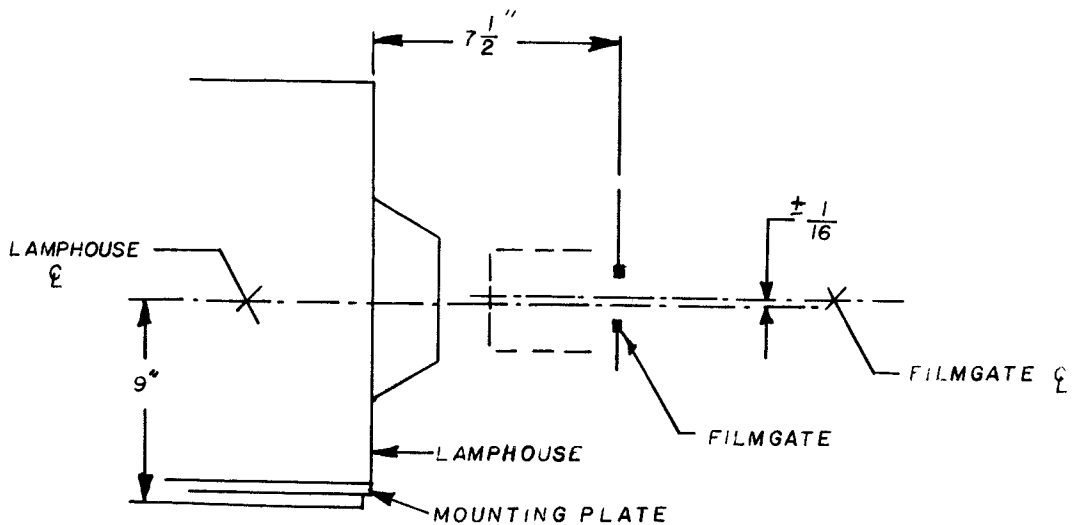

Projector/Lamphouse Alignment Location

Figure 5-1

5.3 INITIAL OPTICAL ALIGNMENT PROCEDURE

Complete the initial start-up procedure outlined in Section 4.16. The following procedure describes the recommended method of initial optical alignment. Systems that have been previously aligned should be re-aligned as outlined in Section 5.4.

a. Remove the projection lens and film from the projector.



Never open the lamphouse douser unless the projector is running. Damage to the shutter, film, and the projection lens could result.

b. Remove shoulder screw from upper mounting plate. Swivel lamphouse and upper base plate around so that it is at a right angle to the direction of the screen.

c. Turn on lamphouse and open douser to direct light from the lamphouse onto the side wall of the projection room. The current should be set to minimum to prevent damage to optical elements.

d. Insert a 3/16 inch hex wrench into the center adjustment hole (AXIAL FOCUS ADJUST, see Figure 4-1), and adjust until the light pattern on the wall resembles a target with a small dark "bullseye" in the approximate center, surrounded by gray rings (see Figure 5-2A). Adjust the horizontal and vertical bulb adjustments (see Figure 4-1) to set the dark bullseye symmetrically in the center of the gray rings (see Figure 5-2B). Turn the center focus adjust clockwise until the dark bullseye just disappears. The bulb is now aligned with respect to the lamphouse mirror.

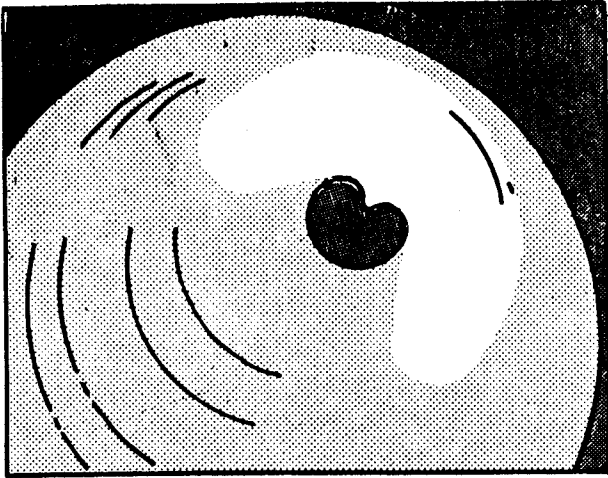

A

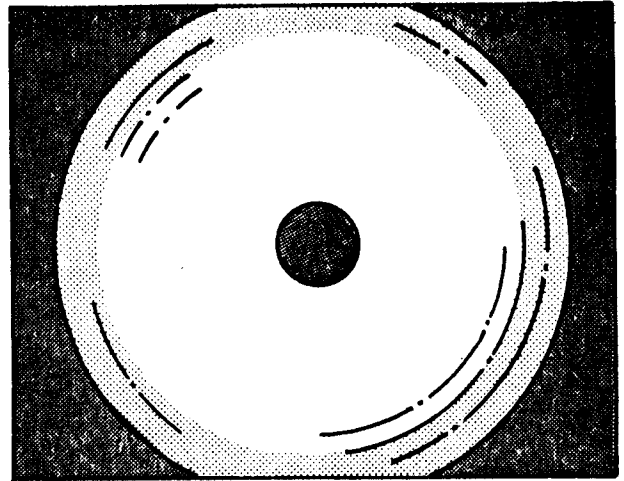

B

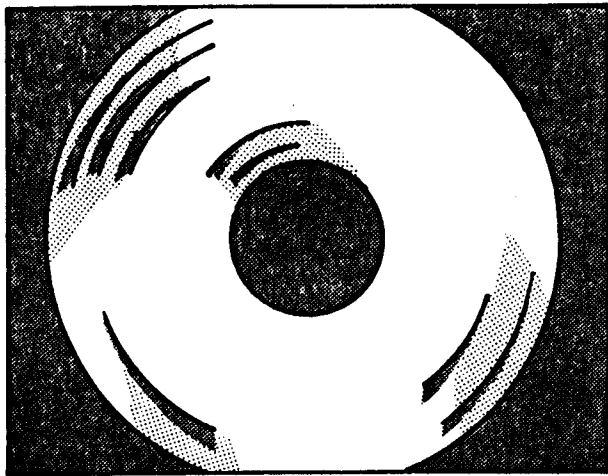

C

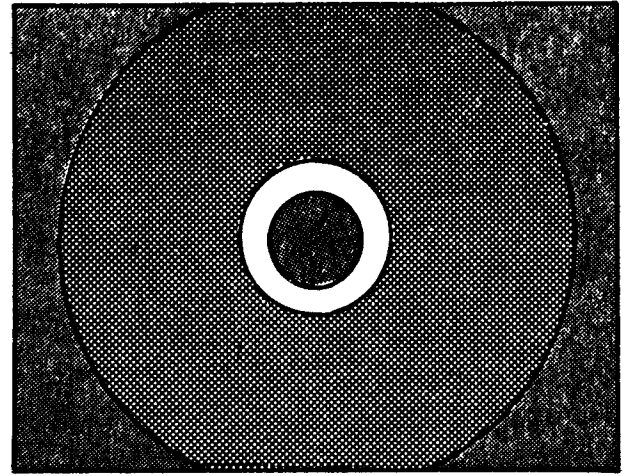

D

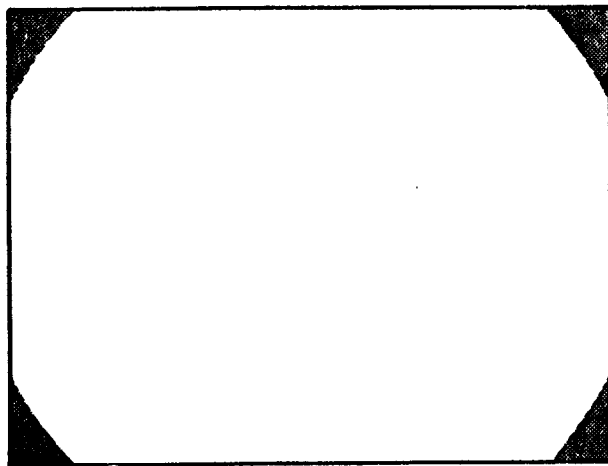

E

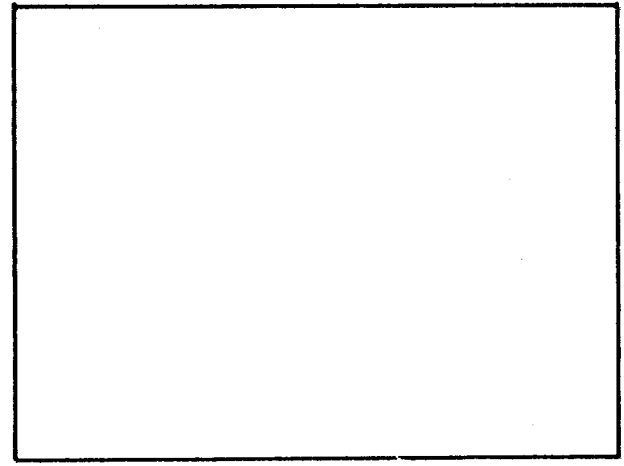

F

Figure 5-2. Alignment Procedure

e. Close the lamphouse douser and swivel the lamphouse into its normal operating position on the projector pedestal with the front bulkhead of the lamphouse approximately seven and one-half to eight inches from the aperture plate of the projector (see Figure 5-1).

f. Start projector and open lamphouse douser and change-over douser. The "target" pattern should now appear on the screen.

NOTE

DO NOT re-adjust the horizontal and vertical bulb adjustments during the following alignment procedures.

g. Center the dark "bullseye" again (see Figure 5-2B) by physically moving the lamphouse table on the projector pedestal up or down as required. If no adjustment is provided, it may be necessary to place shim washers between the lower base plate and the lamphouse table until the desired height is established. If precise centering of the "bullseye" cannot be obtained by moving the lamphouse, repeat steps "a" through "c" to be sure the bulb is centered in the mirror.

h. Adjust the center (axial) focus adjust counter-clockwise until the outer rings begin to converge toward the bullseye. Move the rear of the lamphouse until the bullseye is centered within the outer rings (see Figure 5-2C).

i. Adjust the center focus adjust clockwise until the outer rings converge toward the bullseye to form a dark collar around the bullseye and adjacent ring of light. Adjust the front of the lamphouse to center the bullseye and adjacent ring of light within the outer rings (see Figure 5-2D).

j. Repeat steps "h" and "i" until no further adjustment is necessary to center the bullseye within the adjacent rings of light. After the bullseye has been centered, set center focus adjust half way between the above two alignment positions used in steps "h" and "i".

k. Close the douser and insert projection lens in projector. Open douser, focus projection lens, and adjust center focusing adjustment to obtain a bright spot on the screen.

CAUTION

Do not allow light from lamphouse to strike the projection lens for more than a few seconds at a time. Open the lamphouse douser. Make an adjustment while observing the results on the screen and then close the douser to permit the lens to cool. Prolonged exposure of the lens to the intense light from the lamphouse without film being run through the projector can damage the lens.

l. If the bright spot is not in the center of the screen, re-adjust the lamphouse or horizontal and vertical bulb adjustments slightly to center the pattern. Adjust the center focus adjustment clockwise until the light fills the screen with the exception of the four dark corners (see Figure 5-2E) which should be of equal size.

m. If the four dark corners are not of equal size, repeat step "l".

n. Adjust the center focus adjust clockwise until the screen is filled with light, evenly distributed, with no dark corners (see Figure 5-2F). Readjust the current setting to provide the desired light level on the screen. Do not exceed the maximum safe bulb current.

o. Tighten the four bolts that fasten the lamphouse base to the pedestal.

NOTE

Once the system is properly aligned, no adjustments will be necessary until a new bulb is installed. After installation of a new bulb, adjustment of the three lamp focus adjustments is required to again achieve optimum alignment (see realignment procedure).

5.4 OPTICAL REALIGNMENT

a. Remove the projection lens and film from the projector.

CAUTION

Never open the lamphouse douser unless the projector is running. Damage to the shutter, film, and the projection lens could result.

b. Start the system by completing steps in Section 4.16.

c. Current should be set to minimum to prevent damage to optical elements during alignment procedure.

d. Open the lamphouse douser to project a light pattern on the screen similar to that in Figure 5-2A. If necessary, adjust the center focus adjust control with a 3/16 inch hex wrench to obtain a small, dark "bullseye" in the approximate center.

e. Adjust the horizontal and vertical focus controls with a 3/16 inch hex wrench to obtain a symmetrical pattern similar to that in Figure 5-2B. DO NOT loosen the four bolts holding the lamphouse in place on the pedestal.

f. Close the lamphouse douser and replace the projection lens in the projector. Open the douser, focus the projection lens and adjust the center focus adjust control to obtain a bright spot on the screen.

CAUTION

Do not allow light from the lamphouse to strike the projection lens for more than a few seconds at a time. Open the lamphouse douser. Make an adjustment while observing the results on the screen and then close the douser to permit the lens to cool. Prolonged exposure of the lens to the intense light from the lamphouse without film being run through the projector can damage the lens.

g. Re-adjust the horizontal and vertical focus controls to center the bright spot. Adjust center focus adjust control clockwise until the light fills the screen with the exception of the four dark corners (see Figure 5-2E) which should be approximately equal in size.

h. Adjust the center focus adjust control clockwise until the screen is filled with light, evenly distributed, with no dark corners (see Figure 5-2F). Re-adjust the current setting to provide the desired light level on the screen. Do not exceed the maximum safe bulb current.

WARNING

OPEN THE BRANCH CIRCUIT OR MAIN DISCONNECT SWITCH OR REMOVE PRIMARY INPUT CIRCUIT FUSES BEFORE ATTEMPTING TO MAKE ANY INSPECTION OR PERFORM ANY WORK INSIDE THE LAMPHOUSE. PLACING THE POWER SWITCH IN THE "OFF" POSITION DOES NOT REMOVE VOLTAGE FROM THE POWER SWITCH TERMINALS INSIDE THE LAMPHOUSE.

6.1 CLEANING OPTICS

It is advised that at least twice annually, the electroformed reflector and dichroic filter be cleaned. The following steps are recommended:

- a. Remove the xenon bulb as outlined in Sections 6.2.1 or 6.3.1.
- b. With a soft bristled brush, gently brush larger particles off the surface.
- c. Dampen cotton with clean water and gently wipe the surface.
- d. Gently clean the surface with cotton, dampened with soap and water, or "Glasswax" cleaner manufactured by Gold Seal Company, Bismarck, North Dakota.
- e. Wipe the surfaces gently with cotton until free of streaks and residue.
- f. Replace the xenon bulb as outlined in Sections 6.2.2 or 6.3.2.

6.2 REMOVAL AND REPLACEMENT OF XENON BULB
(XL1000W-XL1600W BULBS)

WARNING

THE XENON BULB IS UNDER EXTREME PRESSURE AND SUBJECT TO POSSIBLE EXPLOSION. DO NOT APPLY LATERAL PRESSURE AGAINST THE BULB DURING REMOVAL OR INSTALLATION. DO NOT VIEW UN-ENCLOSED BULB UNLESS PROTECTIVE FACE MASK IS WORN. THE XENON BULB SHOULD NEVER BE HANDLED OUTSIDE ITS PROTECTIVE CONTAINER OR COVERING UNLESS PROTECTIVE CLOTHING CONSISTING OF GLOVES, FACE SHIELD AND JACKET, AS SPECIFIED IN SECTION 2 OF THIS MANUAL, IS WORN. THE INSTRUCTIONS REGARDING PROTECTIVE CLOTHING ARE SUBJECT TO CHANGE BY ANY LOCAL OR FEDERAL SPECIFICATIONS WHICH TAKE PRECEDENCE.

6.2.1 REMOVAL (See Figure 3-6 or 3-7)

- a. Shut off power to the system. Swivel lamphouse away from projector to gain access through the front bulkhead door.
- b. Unlock the front bulkhead door and swing door upward to allow clearance for bulb removal.
- c. Remove upper wrap from lamphouse exposing focus tube assembly.
- d. Locate the lamp installation/removal tool, ORC P/N 1145648, used to install bulb.
- e. Carefully loosen the socket screws on the anode (+) connector with a 9/64 inch hex wrench. Support the end of the bulb with one hand so that lateral pressure is not applied on the bulb. Remove the anode connector from the anode stud of the bulb.

f. (XH-30S Lamphouse Only) Locate the wing-nut on the anode support assembly and loosen to allow removal of the support with anode connector, ORC P/N 1134986-3, and set support assembly off to one side (see Figure 3-8).

g. Install the bulb installation/removal tool over the bulb. Do not exert any bending pressure on the bulb. Rotate the tool carefully around the bulb until it slips over the indexing pins on the cathode (-) fitting (behind the mirror) and slips down over the anode stud. Locate the retaining collar. Place it over the stud and tighten the set screw with a 1/8 inch hex wrench.

h. Loosen the two set screws in the cathode receptacle behind the reflector. Carefully remove the xenon bulb with installation/removal tool in place, from the lamphouse.

i. Unthread the cathode adapter, ORC P/N 1121700-1, from the cathode fitting of the bulb. Replace the red plastic end cap, retaining bracket, and wing-nut on the installation/removal tool.

j. Place the bulb in a suitable shipping carton for return to Optical Radiation Corporation for disposal, or warranty credit.

k. Clean lamphouse if necessary by vacuuming or using dry compressed air. Clean optics as outlined in Section 6.1.

6.2.2 REPLACEMENT (see Figure 3-6 or 3-7)

a. Take the xenon bulb to be installed from its shipping container and remove the wing-nut, retaining bracket, and red plastic end cap from the cathode end of the bulb installation/removal tool.

b. Find the cathode adapter, ORC P/N 1121700-1, and thread it on to the cathode (-) fitting of the xenon bulb until snug.

c. With the bulb still contained within the bulb installation/removal tool, insert the bulb, cathode end with adapter first, into the opening at the center of the reflector. Carefully feed the adapter stud into its mating receptacle behind the reflector until the adapter is seated against the mating surface. Tighten the two set screws in the receptacle.

d. Carefully remove the collar holding the bulb installation/removal tool to the anode (+) fitting of the bulb with a 1/8 inch hex wrench.

CAUTION

Do not touch quartz surface of bulb with bare hands. Finger contact with bulb surface will leave body oil marks which could result in fracture or explosion of the bulb during operation. If the bulb becomes contaminated, it should be cleaned with pure alcohol. Wear protective clothing.

e. Remove the bulb installation/removal tool from the bulb. Do not exert any bending pressure on the bulb.

f. (XH-30S Lamphouse Only) Replace anode support assembly with anode connector, ORC P/N 1134986-3, and tighten the retaining wing-nut (see Figure 3-8).

g. Place the anode connector over the anode stud of the bulb and carefully tighten the socket screws on the connector with a 9/64 inch hex wrench. Support the end of the bulb with one hand while tightening so that lateral pressure is not applied on the bulb.

CAUTION

Make sure front lead from igniter to bulb is not touching any part of mirror or high voltage arcing and shorting may occur.

h. Lower front bulkhead door into place and secure by locking and removing key. Replace and secure upper wrap.

i. Swivel lamphouse back into position for re-alignment (Section 5.4) and operation.

6.3 REMOVAL AND REPLACEMENT OF XENON BULB
(MODEL XH-30S LAMPHOUSE ONLY, XL2000W - XL2500W BULBS)

WARNING

THE XENON BULB IS UNDER EXTREME PRESSURE AND SUBJECT TO POSSIBLE EXPLOSION. DO NOT APPLY LATERAL PRESSURE AGAINST THE BULB DURING INSTALLATION. DO NOT VIEW UN-ENCLOSED BULB UNLESS PROTECTIVE FACE MASK IS WORN. BULB SHOULD NEVER BE HANDLED OUTSIDE ITS PROTECTIVE CONTAINER OR COVERING UNLESS PROTECTIVE CLOTHING CONSISTING OF GLOVES, FACE SHIELD AND JACKET, AS SPECIFIED IN SECTION 2 OF THIS MANUAL, IS WORN. THE INSTRUCTIONS REGARDING PROTECTIVE CLOTHING ARE SUBJECT TO CHANGE BY ANY LOCAL OR FEDERAL SPECIFICATIONS WHICH TAKE PRECEDENCE.

6.3.1 REMOVAL (see Figure 3-6 or 3-7)

a. Shut off power to the system. Swivel lamphouse away from projector to gain access through the front bulkhead door.

b. Unlock the front bulkhead door and swing door upward to allow clearance for bulb removal.

c. Remove upper wrap from lamphouse, exposing focus tube assembly.

d. Locate the protective plastic wrap, ORC P/N 1135517, used to install the bulb.

e. Carefully place the plastic wrap around the bulb without pulling or exerting any bending pressure on the bulb.

- f. Disconnect anode (+) lead from bulb to high voltage terminal of the ignitor transformer.
- g. Loosen set screws on anode end of bulb.
- h. Locate the wing-nut on the anode support assembly and loosen to allow removal of support with anode connector, ORC P/N 1124915 , and set support assembly off to one side. Support anode fitting of bulb with one hand until bulb is removed.
- i. Loosen the two set screws in the cathode (-) receptacle behind the reflector. Carefully remove the xenon bulb, with protective plastic wrap in place, from the lamphouse.
- j. Securely wrap protective plastic wrap around bulb and tighten end string ties.
- k. Place the bulb in a suitable shipping carton for return to Optical Radiation Corporation for disposal, or warranty credit.
- l. Clean lamphouse if necessary by vacuuming or using dry, compressed air. Clean optics as outlined in Section 6.1.

6.3.2 REPLACEMENT (see Figure 3.6 or 3.7)

- a. Take the xenon bulb to be installed from its shipping container.
- b. At installation, loosen end string ties on plastic wrap. Unwrap ends of plastic wrap preparing it for easy removal once bulb is installed.
- c. Insert the bulb, cathode (-) end first, into the opening at the center of the reflector. Carefully feed the cathode stud into its mating receptacle behind the reflector until the bulb is seated against the mating surface.
- d. Replace anode (+) support assembly with anode connector, ORC P/N 1124915 , and tighten the retaining wing-nut.

e. Make certain shoulder of bulb is flush with cathode mounting receptacle, then tighten two set screws in mounting receptacle.

f. Firmly tighten set screws on anode end of bulb.

g. Attach anode lead from bulb to high voltage terminal of the ignitor transformer. Tighten screw securely but be careful not to shear stud of high voltage terminal by applying excessive pressure.

CAUTION

Do not touch quartz surface of bulb with bare hands. Finger contact with bulb surface will leave body oil marks which could result in fracture or explosion of the bulb during operation. If the bulb becomes contaminated, it should be cleaned with pure alcohol. Wear protective clothing.

h. Carefully remove the plastic wrap from the bulb without pulling or exerting any bending pressure on the bulb.

CAUTION

Make sure front lead from ignitor to the bulb is not touching any part of mirror or high voltage arcing and shorting may occur.

i. Lower front bulkhead door into place and secure by locking and removing key. Replace and secure upper wrap.

j. Swivel lamphouse back into position for re-alignment (Section 5.4) and operation.

6.4 TROUBLESHOOTING

If the lamphouse should fail to operate properly, consult the schematic diagram, Dwg. No. 1145038 or wiring diagrams 1136545, 1136546, 1136547 and 1137128 as a guide in determining the possible trouble. If the system malfunction cannot be isolated or corrected with the aid of the enclosed schematic diagrams and assembly drawings, it is recommended that the dealer be contacted to provide assistance.

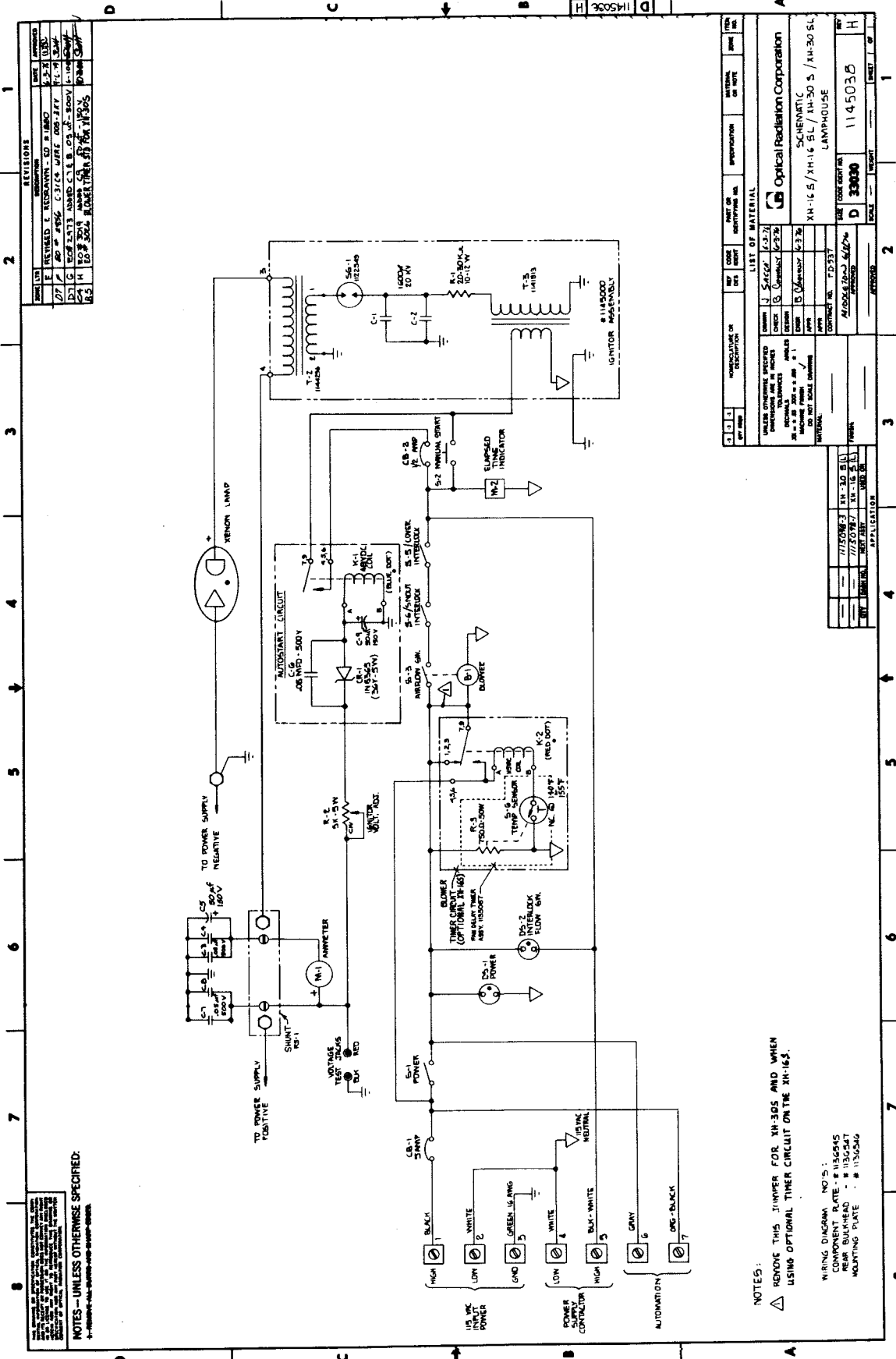

REV.	DATE	DESCRIPTION	BY	CHKD.
1		REVISED TO COMPLY WITH MIL-STD-1300		
2		REVISED TO COMPLY WITH MIL-STD-1300		
3		REVISED TO COMPLY WITH MIL-STD-1300		
4		REVISED TO COMPLY WITH MIL-STD-1300		
5		REVISED TO COMPLY WITH MIL-STD-1300		

NOTES - UNLESS OTHERWISE SPECIFIED:
 * - RESISTOR - ALL VALUES - 5% TOLERANCE - UNLESS OTHERWISE SPECIFIED

NOTES:
 Δ REMOVE THIS TIMER FOR XH-30S AND WHEN USING OPTIONAL TIMER CIRCUIT ON THE XH-16S.

WIRING DIAGRAM NO. 5:
 COMPONENT PLATE - # 113054S
 REAR BULKHEAD - # 113054T
 MOUNTING PLATE - # 113054G

LIST OF MATERIAL			
QTY.	DESCRIPTION	UNIT	REMARKS
1	CHASSIS	PCB	
1	COVER	PCB	
1	REAR BULKHEAD	PCB	
1	MOUNTING PLATE	PCB	
1	WIRING DIAGRAM	PCB	

PREPARED BY	DESIGNED BY	APPROVED BY
DATE	DATE	DATE

SCALE	1:1
WEIGHT	114.5030B
QUANTITY	D 33000

COMPONENT	NO.	REV.
WIRING DIAGRAM	NO. 5	
COMPONENT PLATE	# 113054S	
REAR BULKHEAD	# 113054T	
MOUNTING PLATE	# 113054G	

THIS DRAWING OR SPECIFICATION CONSTITUTES THE COMPLETE AND EXCLUSIVE PROPERTY OF OPTICAL RADIATION CORPORATION. NO PART OF THIS DRAWING OR SPECIFICATION IS TO BE REPRODUCED OR TRANSMITTED IN ANY FORM OR BY ANY MEANS, ELECTRONIC OR MECHANICAL, INCLUDING PHOTOCOPYING, RECORDING, OR BY ANY INFORMATION STORAGE AND RETRIEVAL SYSTEM, WITHOUT THE WRITTEN CONSENT OF OPTICAL RADIATION CORPORATION.

NOTES - UNLESS OTHERWISE SPECIFIED:

- 1. REMOVE REWORKING AND DEFERRALS.
- 2. ALL WIRES TO BE COATING MINIMUM UNLESS OTHERWISE SPECIFIED.
- 3. POTENTIOMETER R-2 VIEWED FROM BACK SIDE

REVISIONS				
ZONE	LTN	DESCRIPTION	DATE	APPROVED
A	EO # 2164		3/7/77	
B	EO # 2173	ADDED C-7, E-8, OS, R-3001	4/12/80	Scott

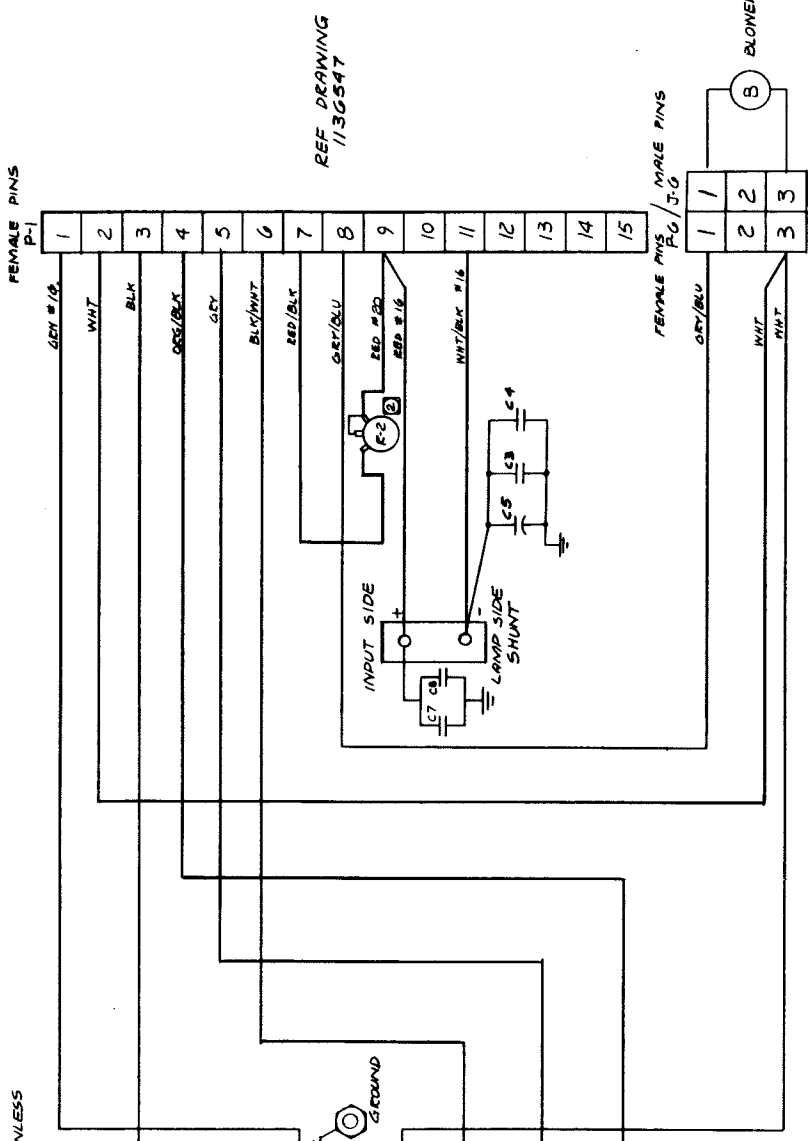

FOR REFERENCE
SCHEMATIC # 114503B
ASSY # 1145031

QTY	NO	SYN	DESCRIPTION	REF DES	IDENTIFYING NO.	SPECIFICATION	MATERIAL OR NOTE	ITEM NO.
1	1		WHT					
1	2		WHT					
1	3		WHT					

LIST OF MATERIAL	
DRAWN	J. Sacco
CHECK	12/1/76
DESIGN	
ENGR	(Signature)
APPR	
CONTRACT NO.	PR-337

UNLESS OTHERWISE SPECIFIED
DIMENSIONS IN INCHES
TOLERANCES
DECIMALS
ANGLES
XX = ± .03 XXX = ± .010 ± 1/2°
MACHINE FINISH
DO NOT SCALE DRAWING
MATERIAL:
FINISH:

QTY	DASH NO.	NEXT ASSY	APPLICATION

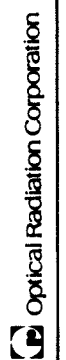

WIRING DIAGRAM
COMPONENT PLATE

SIZE	CODE	IDENT NO	REV
C	33030	1136545	B

SCALE	WEIGHT	SHEET	1 OF 1

REV	DATE	DESCRIPTION	APPROVED
1			

NOTES - UNLESS OTHERWISE SPECIFIED:

- 1. ALL WIRES TO BE 20 AWG MINIMUM UNLESS OTHERWISE SPECIFIED
- 2. CUT THIS GRAY/BLU WIRE WHEN USING FAN DELAY TIMER

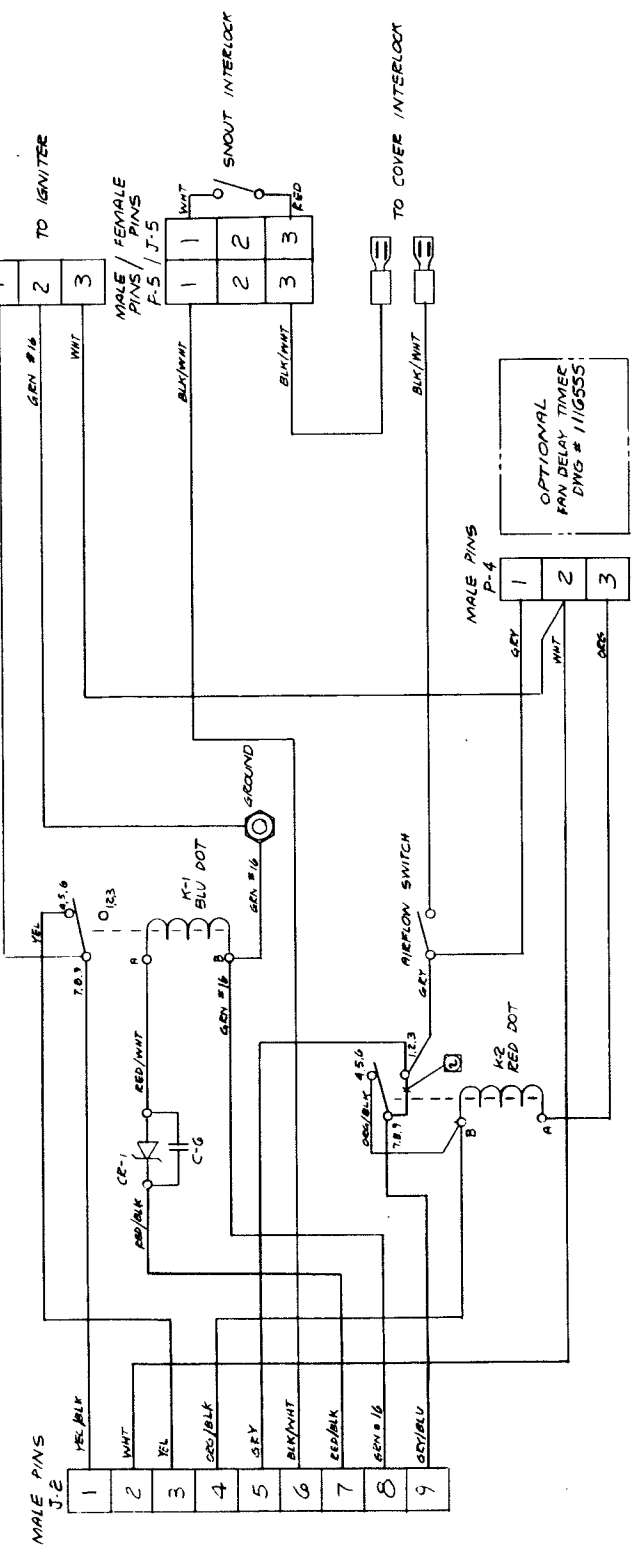

SEE DRAWING 1136547

FOR REFERENCE SCHEMATIC: # 1145038 ASSEMBLY: # 1145006

QTY	REQ	SYM	NOMENCLATURE OR DESCRIPTION	REF DES IDENT	PART OR IDENTIFYING NO	SPECIFICATION	MATERIAL OR NOTE	ZONE	ITEM NO.

LIST OF MATERIAL	
DRAWN	J. SAGGA 3/19/74
CHECK	
DESIGN	
ENGR	W. S. Gandy 12/29/76
APPR	
APPR	
CONTRACT NO.	PD 537

UNLESS OTHERWISE SPECIFIED DIMENSIONS ARE IN INCHES	
TOLERANCES	ANGLES
XX ± 0.3 XXX ± 0.10 ± 1/2°	
MACHINE FINISH	✓
DO NOT SCALE DRAWING	
MATERIAL:	
FINISH:	

SIZE	CODE IDENT NO	SCALE	WEIGHT	SHEET 1 OF 1
C	33030		1136546	1

QTY	DASH NO.	NEXT ASSY	USED ON
		XH-1620	

QTY	DASH NO.	NEXT ASSY	USED ON
		XH-1620	

APPLICATION

THIS DRAWING OR SPECIFICATION CONSTITUTES THE COMPLETE INFORMATION FOR THE MANUFACTURE OF THE PART OR ASSEMBLY. IT IS THE RESPONSIBILITY OF THE MANUFACTURER TO OBTAIN ALL NECESSARY PERMISSIONS AND TO OBTAIN ALL INFORMATION NECESSARY TO USE IT. NO PART OF THIS DRAWING OR SPECIFICATION IS TO BE REPRODUCED OR TRANSMITTED IN ANY FORM OR BY ANY MEANS WITHOUT THE WRITTEN CONSENT OF OPTICAL RADIATION CORPORATION.

NOTES - UNLESS OTHERWISE SPECIFIED:
 1. ~~MINIMUM~~ **MINIMUM** UNLESS OTHERWISE SPECIFIED.
 ALL DIMENSIONS TO BE TO ANG OTHERWISE SPECIFIED.

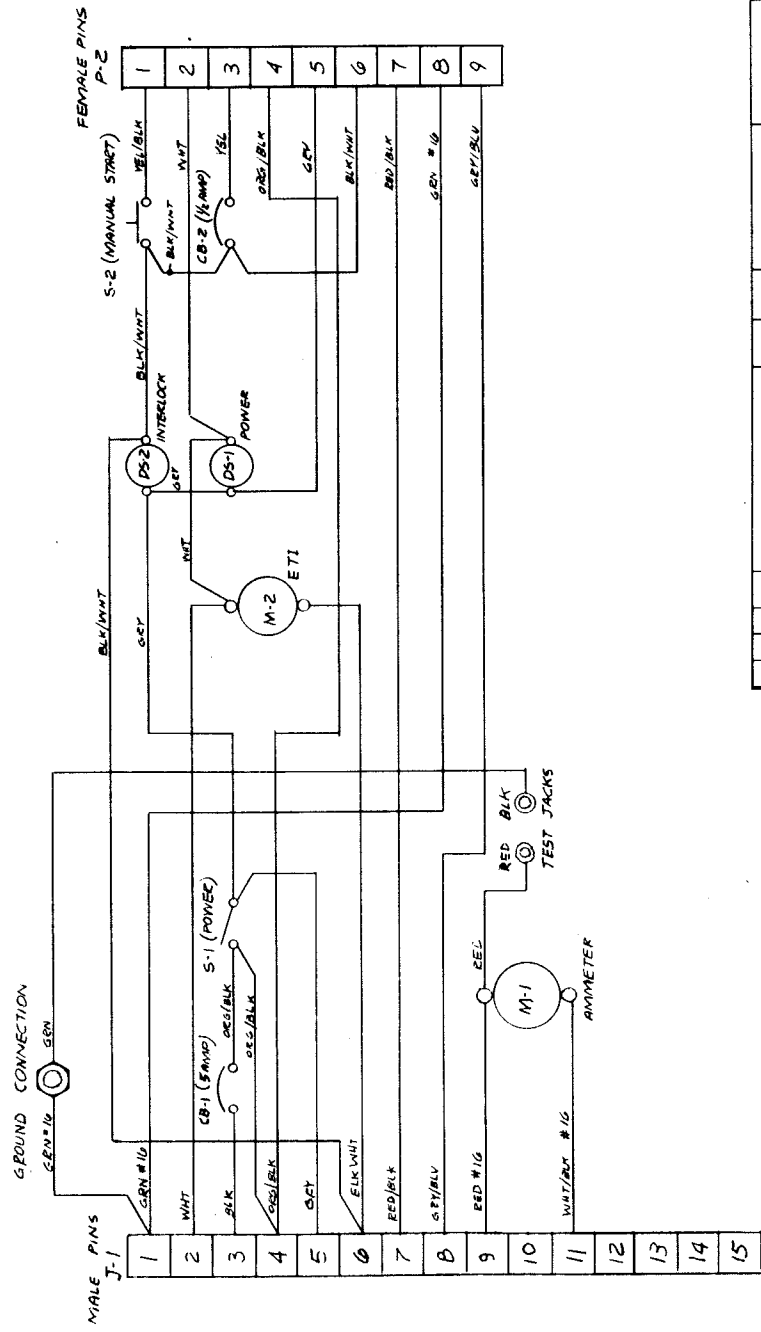

REF. DRAWING # 1136546

REF. DRAWING # 1136545

ZONE	LTR	DESCRIPTION	DATE	APPROVED

QTY	REQD	SYM	NOMENCLATURE OR DESCRIPTION	REF DES	CODE IDENT	PART OR IDENTIFYING NO.	SPECIFICATION	MATERIAL OR NOTE	ZONE	ITEM NO.

LIST OF MATERIAL

DRAWN J. S. ACCA CHECK DESIGN ENGR APPR CONTRACT NO. PD-537	UNLESS OTHERWISE SPECIFIED DIMENSIONS ARE IN INCHES TOLERANCES DECIMALS .003 XXX ± .010 ± .12" ANGLES MACHINE FINISH DO NOT SCALE DRAWING MATERIAL	Optical Radiation Corporation WIRING DIAGRAM REAR BULKHEAD	SIZE CODE IDENT NO C 33030 1136547 REV N/C
--	---	--	--

QTY	DASH NO.	NEXT ASSY	USED ON	APPLICATION
			XH-10/30	

FOR REFERENCE
 SCHEMATIC # 1145038
 ASSY # 1145093

REVISIONS		DATE	APPROVED
ZONE	LTR		

QTY	REF	SYM	NOMENCLATURE OR DESCRIPTION	CODE IDENT	PART OR IDENTIFYING NO.	SPECIFICATION	MATERIAL OR NOTE	ZONE	ITEM NO.
1	1		BR-301 VH-447						

NOTES - UNLESS OTHERWISE SPECIFIED:

1. SINGLE POLE SINGLE THROW SWITCH NOT SUPPLIED. 115VAC 3A RATING REQUIRED.

2. EXISTING WIRING SHOWN DASHED. REFERENCE WIRING DIAGRAM 1136545, SCHEMATIC 114503B, AND ASSEMBLY 1147129.

3. ALL WIRING NO. 20 AWG MINIMUM.

4. JACK IS FEMALE CONNECTOR WITH FEMALE PINS, PLUG IS MALE CONNECTOR WITH MALE PINS.

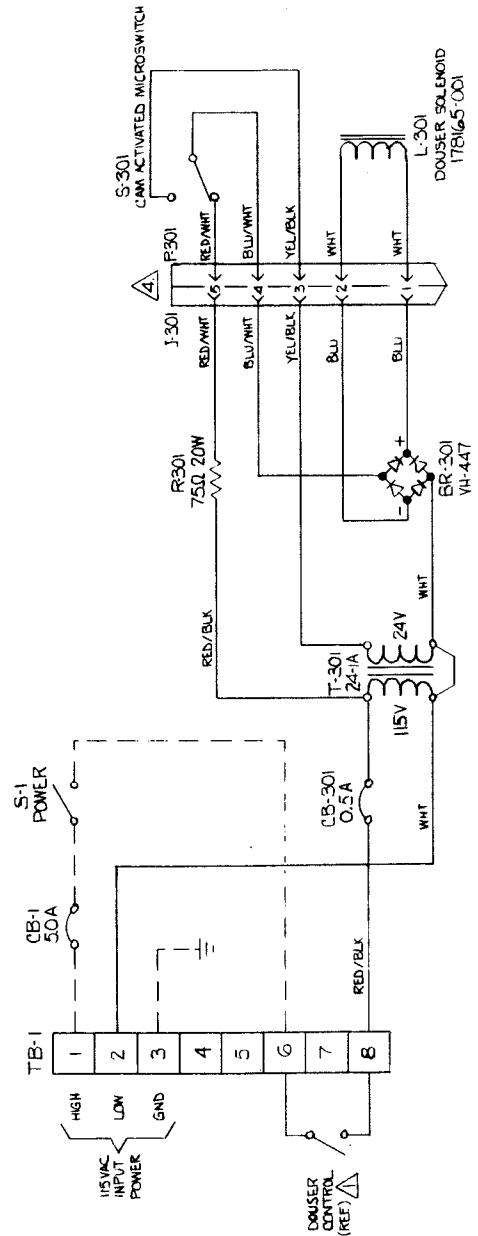

UNLESS OTHERWISE SPECIFIED DIMENSIONS ARE IN INCHES		DRAWN	IB CONNELLY	1614777
TOLERANCES	CHECK	DESIGN		
DECIMALS	ANGLES	ENGR		
XX ± .03 XXX ± .010 ± 1/2"		DO NOT SCALE DRAWING		
MACHINE FINISH		MATERIAL		
CONTRACT NO. PD-537-00		APPROVED		
FINISH:		APPROVED		

Optical Radiation Corporation	WIRING DIAGRAM
ADDITIONAL-REMOTE DOUSER OPTION	XH-165
SIZE CODE IDENT NO. C 33030	1137128
SCALE	HEIGHT
SHEET	OF

QTY	DASH NO.	NEXT ASSY	USED ON
			XH-165
APPLICATION			

QTY	DASH NO.	NEXT ASSY	USED ON
			XH-165
APPLICATION			

SECTION 7 - BULB WARRANTY

The bulb warranty on the xenon bulb will not be honored unless the necessary forms are completed.

Upon installation of a new bulb, the xenon lamp warranty card must be filled out and returned to Optical Radiation Corporation. It is mandatory that all information on the card be completed. Shown below is a sample card which was included with delivery.

This card must be filled out and returned within 30 days after installation of the lamp to validate the warranty of your new xenon lamp.

XENON LAMP WARRANTY CARD

USER'S NAME _____ DATE _____
COMPANY _____
STREET ADDRESS _____
CITY _____ STATE _____ ZIP _____
LAMP MODEL NO. _____ SERIAL NO. _____
INSTALLED IN _____ MODEL NO. _____
SERIAL NO. _____
RUNNING TIME METER READING AT TIME OF INSTALLATION _____ HRS.
PURCHASED FROM _____
CITY _____

READ ALL INSTRUCTIONS BEFORE INSTALLING LAMP

If the bulb has failed during the warranty period, the xenon lamp warranty claim form must be filled out and returned to Optical Radiation Corporation along with the defective bulb.

XENON LAMP
WARRANTY CLAIM FORM

To expedite warranty claims, please fill out the following as completely as possible and return with defective bulb to Optical Radiation Corporation:

1. Bulb Model No. _____ Serial No. _____
Purchase Date _____

2. Equipment
Lamphouse Type: Model No. _____
Serial No. _____

3. Operating Conditions
Accumulated Running Hours on Bulb _____
Average ON Time _____ Average OFF Time _____
Estimated Number of Ignitions _____
Voltage at Failure _____ Current at Failure _____

4. Conditions Causing Reject or Return _____

5. Additional Information _____

Form Completed By _____ Title _____

Company _____

Address _____

Telephone No. _____ Date _____

Return To:

Optical Radiation Corporation
6352 N. Irwindale Avenue, Azusa, California 91702 • (213) 969-3344

~~SECTION 8 - LAMPHOUSE DATA/DRAWINGS~~

The following list and pages of assembly drawings contain the majority of parts used in the XH-16S and XH-30S lamphouses. When ordering spare or replacement parts, please specify complete part number, description, system to be used in, and quantity required. Consult your local dealer or Optical Radiation Corporation for prices.

NOTES - UNLESS OTHERWISE SPECIFIED:
 1. REMOVE ALL BURNS AND SWAP MARKS.
 2. THESE CENTER BULKHEAD ASSEMBLIES ARE ALIVE EXCEPT
 THE TUBES AND TUBING WHICH ARE REMOVED BY THE USER.
 3. USE THE CENTER BULKHEAD ASSEMBLY (TYPE 2520) IN THE
 TUBING ASSEMBLY (TYPE 2520) WITH XL-1600W LAMP (OPTIONAL).
 4. THESE CENTER BULKHEAD ASSEMBLIES ARE ALIVE EXCEPT
 THE TUBES AND TUBING WHICH ARE REMOVED BY THE USER.

ITEM 24
 NOT SHOWN
 SHOWN LOOSE

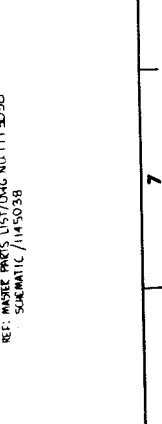
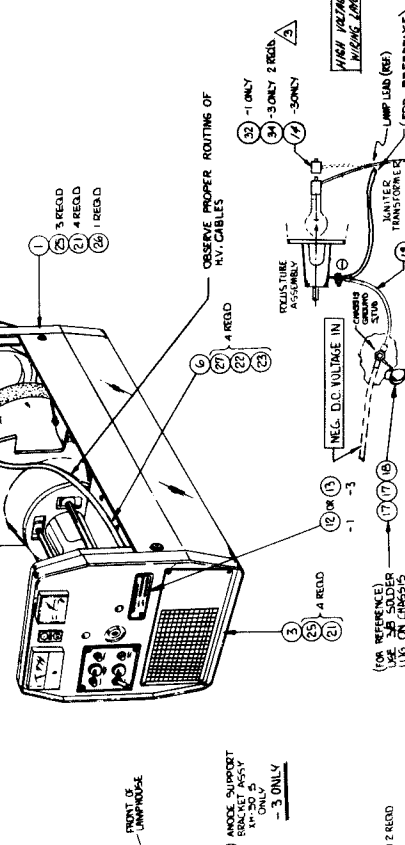

REVISED		DESCRIPTION	
DATE	BY	REV	DESCRIPTION
11/15/50	W. B. B.	1	ASSEMBLY
12/15/50	W. B. B.	2	REVISION
1/15/51	W. B. B.	3	REVISION
2/15/51	W. B. B.	4	REVISION
3/15/51	W. B. B.	5	REVISION
4/15/51	W. B. B.	6	REVISION
5/15/51	W. B. B.	7	REVISION
6/15/51	W. B. B.	8	REVISION
7/15/51	W. B. B.	9	REVISION
8/15/51	W. B. B.	10	REVISION
9/15/51	W. B. B.	11	REVISION
10/15/51	W. B. B.	12	REVISION
11/15/51	W. B. B.	13	REVISION
12/15/51	W. B. B.	14	REVISION
1/15/52	W. B. B.	15	REVISION
2/15/52	W. B. B.	16	REVISION
3/15/52	W. B. B.	17	REVISION
4/15/52	W. B. B.	18	REVISION
5/15/52	W. B. B.	19	REVISION
6/15/52	W. B. B.	20	REVISION
7/15/52	W. B. B.	21	REVISION
8/15/52	W. B. B.	22	REVISION
9/15/52	W. B. B.	23	REVISION
10/15/52	W. B. B.	24	REVISION
11/15/52	W. B. B.	25	REVISION
12/15/52	W. B. B.	26	REVISION
1/15/53	W. B. B.	27	REVISION
2/15/53	W. B. B.	28	REVISION
3/15/53	W. B. B.	29	REVISION
4/15/53	W. B. B.	30	REVISION
5/15/53	W. B. B.	31	REVISION
6/15/53	W. B. B.	32	REVISION
7/15/53	W. B. B.	33	REVISION
8/15/53	W. B. B.	34	REVISION
9/15/53	W. B. B.	35	REVISION

ITEM	DESCRIPTION	QTY	UNIT	REVISION
1	CHASSIS-MOUNT SOCKET	1	PCB	
2	LAMPING INST. TAG	1	PCB	
3	ANODE ADAPTER ASSY	1	PCB	
4	NUT-NEPS	1	PCB	
5	SCREW-PH HD PHIL	1	PCB	
6	SCREW-FLAT HD PHIL	1	PCB	
7	SCREW-PH HD PHIL	1	PCB	
8	SCREW-TRI-WING	1	PCB	
9	SCREW-OVAL HD PHIL	1	PCB	
10	LENS KIT	1	PCB	
11	WASHER-LOCK	1	PCB	
12	WASHER-FLAT	1	PCB	
13	WASHER-DECORATIVE	1	PCB	
14	LEAD-D.C.	1	PCB	
15	CAPACITOR	1	PCB	
16	CAPACITOR/DISC	1	PCB	
17	LEAD-D.C.	1	PCB	
18	ANODE LEAD	1	PCB	
19	ADAPTOR ANODE ASSEMBLY	1	PCB	
20	SERIAL NO. TAG	1	PCB	
21	SERIAL NO. TAG	1	PCB	
22	MTG. PLATE ASSY	1	PCB	
23	LAMPING INSTRUCT. TAG	1	PCB	
24	ANODE SUPPORT ASSY	1	PCB	
25	CENTER BULKHEAD ASSY	1	PCB	
26	MTG. PLATE ASSY	1	PCB	
27	UPPER WIND ASSY	1	PCB	
28	LOWER WIND ASSY	1	PCB	
29	REAR BULKHEAD ASSY	1	PCB	
30	CENTER BULKHEAD ASSY	1	PCB	
31	FRONT BULKHEAD ASSY	1	PCB	
32	INDUCTOR OR RESISTOR	1	PCB	
33	RESISTOR	1	PCB	
34	CAPACITOR	1	PCB	
35	INDUCTOR	1	PCB	

LIST OF MATERIAL	QTY	UNIT
1	1	PCB
2	1	PCB
3	1	PCB
4	1	PCB
5	1	PCB
6	1	PCB
7	1	PCB
8	1	PCB
9	1	PCB
10	1	PCB
11	1	PCB
12	1	PCB
13	1	PCB
14	1	PCB
15	1	PCB
16	1	PCB
17	1	PCB
18	1	PCB
19	1	PCB
20	1	PCB
21	1	PCB
22	1	PCB
23	1	PCB
24	1	PCB
25	1	PCB
26	1	PCB
27	1	PCB
28	1	PCB
29	1	PCB
30	1	PCB
31	1	PCB
32	1	PCB
33	1	PCB
34	1	PCB
35	1	PCB

LIST OF MATERIAL		DESCRIPTION	
QTY	UNIT	DESCRIPTION	REVISION
1	1	CHASSIS-MOUNT SOCKET	
2	1	LAMPING INST. TAG	
3	1	ANODE ADAPTER ASSY	
4	1	NUT-NEPS	
5	1	SCREW-PH HD PHIL	
6	1	SCREW-FLAT HD PHIL	
7	1	SCREW-PH HD PHIL	
8	1	SCREW-TRI-WING	
9	1	SCREW-OVAL HD PHIL	
10	1	LENS KIT	
11	1	WASHER-LOCK	
12	1	WASHER-FLAT	
13	1	WASHER-DECORATIVE	
14	1	LEAD-D.C.	
15	1	CAPACITOR	
16	1	CAPACITOR/DISC	
17	1	LEAD-D.C.	
18	1	ANODE LEAD	
19	1	ADAPTOR ANODE ASSEMBLY	
20	1	SERIAL NO. TAG	
21	1	SERIAL NO. TAG	
22	1	MTG. PLATE ASSY	
23	1	LAMPING INSTRUCT. TAG	
24	1	ANODE SUPPORT ASSY	
25	1	CENTER BULKHEAD ASSY	
26	1	MTG. PLATE ASSY	
27	1	UPPER WIND ASSY	
28	1	LOWER WIND ASSY	
29	1	REAR BULKHEAD ASSY	
30	1	CENTER BULKHEAD ASSY	
31	1	FRONT BULKHEAD ASSY	
32	1	INDUCTOR OR RESISTOR	
33	1	RESISTOR	
34	1	CAPACITOR	
35	1	INDUCTOR	

LIST OF MATERIAL		DESCRIPTION	
QTY	UNIT	DESCRIPTION	REVISION
1	1	CHASSIS-MOUNT SOCKET	
2	1	LAMPING INST. TAG	
3	1	ANODE ADAPTER ASSY	
4	1	NUT-NEPS	
5	1	SCREW-PH HD PHIL	
6	1	SCREW-FLAT HD PHIL	
7	1	SCREW-PH HD PHIL	
8	1	SCREW-TRI-WING	
9	1	SCREW-OVAL HD PHIL	
10	1	LENS KIT	
11	1	WASHER-LOCK	
12	1	WASHER-FLAT	
13	1	WASHER-DECORATIVE	
14	1	LEAD-D.C.	
15	1	CAPACITOR	
16	1	CAPACITOR/DISC	
17	1	LEAD-D.C.	
18	1	ANODE LEAD	
19	1	ADAPTOR ANODE ASSEMBLY	
20	1	SERIAL NO. TAG	
21	1	SERIAL NO. TAG	
22	1	MTG. PLATE ASSY	
23	1	LAMPING INSTRUCT. TAG	
24	1	ANODE SUPPORT ASSY	
25	1	CENTER BULKHEAD ASSY	
26	1	MTG. PLATE ASSY	
27	1	UPPER WIND ASSY	
28	1	LOWER WIND ASSY	
29	1	REAR BULKHEAD ASSY	
30	1	CENTER BULKHEAD ASSY	
31	1	FRONT BULKHEAD ASSY	
32	1	INDUCTOR OR RESISTOR	
33	1	RESISTOR	
34	1	CAPACITOR	
35	1	INDUCTOR	

REVISIONS:
 1. 11/15/50
 2. 12/15/50
 3. 1/15/51
 4. 2/15/51
 5. 3/15/51
 6. 4/15/51
 7. 5/15/51
 8. 6/15/51
 9. 7/15/51
 10. 8/15/51
 11. 9/15/51
 12. 10/15/51
 13. 11/15/51
 14. 12/15/51
 15. 1/15/52
 16. 2/15/52
 17. 3/15/52
 18. 4/15/52
 19. 5/15/52
 20. 6/15/52
 21. 7/15/52
 22. 8/15/52
 23. 9/15/52
 24. 10/15/52
 25. 11/15/52
 26. 12/15/52
 27. 1/15/53
 28. 2/15/53
 29. 3/15/53
 30. 4/15/53
 31. 5/15/53
 32. 6/15/53
 33. 7/15/53
 34. 8/15/53
 35. 9/15/53

REVISIONS	
1	ISSUED FOR PRODUCTION
2	ISSUED FOR PRODUCTION
3	ISSUED FOR PRODUCTION
4	ISSUED FOR PRODUCTION
5	ISSUED FOR PRODUCTION
6	ISSUED FOR PRODUCTION
7	ISSUED FOR PRODUCTION
8	ISSUED FOR PRODUCTION
9	ISSUED FOR PRODUCTION
10	ISSUED FOR PRODUCTION

NO.	REV.	DESCRIPTION	DATE
1		ISSUED FOR PRODUCTION	
2		ISSUED FOR PRODUCTION	
3		ISSUED FOR PRODUCTION	
4		ISSUED FOR PRODUCTION	
5		ISSUED FOR PRODUCTION	
6		ISSUED FOR PRODUCTION	
7		ISSUED FOR PRODUCTION	
8		ISSUED FOR PRODUCTION	
9		ISSUED FOR PRODUCTION	
10		ISSUED FOR PRODUCTION	

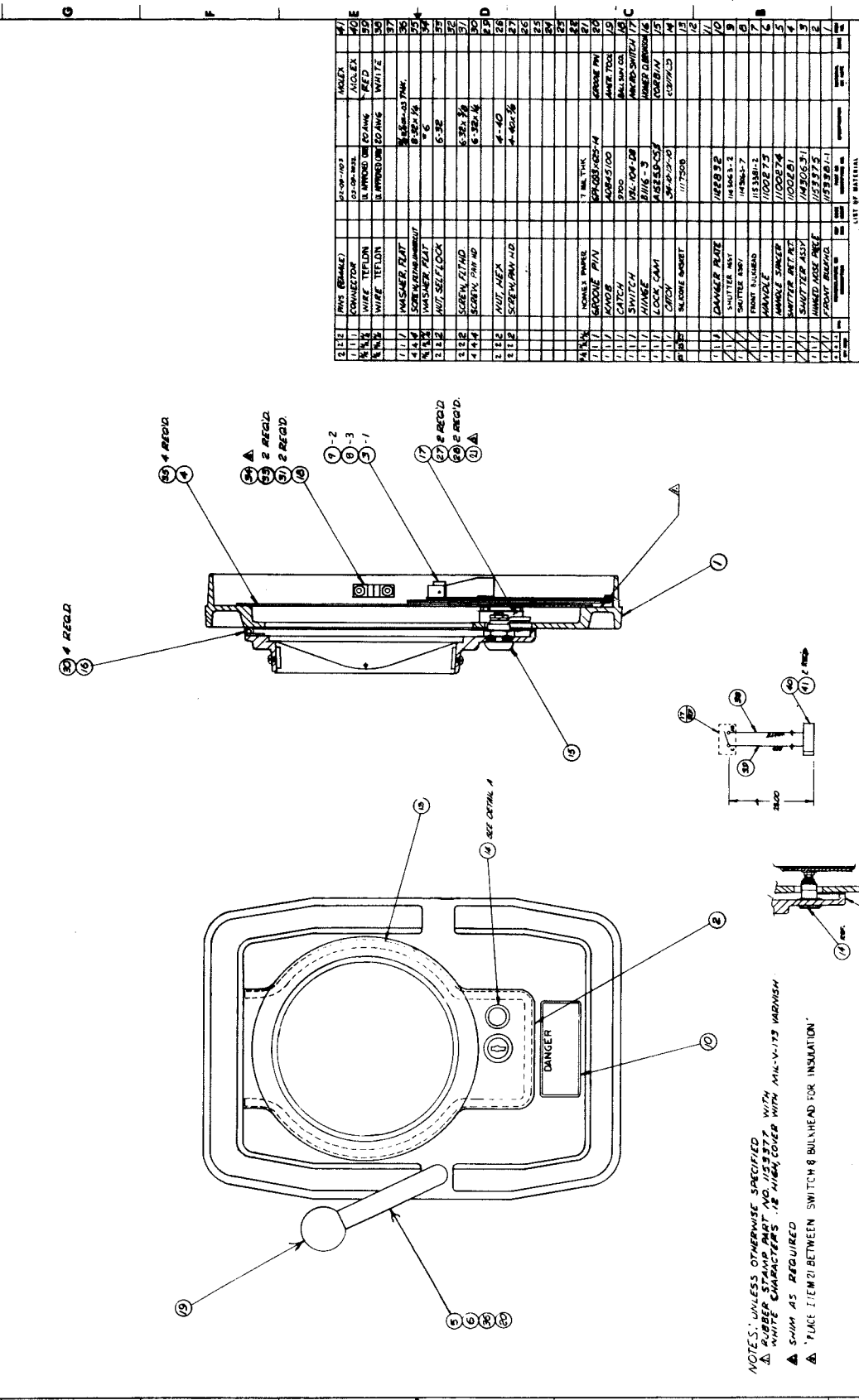

LIST OF MATERIAL	
1	FRONT BULKHEAD
2	FRONT BULKHEAD
3	FRONT BULKHEAD
4	FRONT BULKHEAD
5	FRONT BULKHEAD
6	FRONT BULKHEAD
7	FRONT BULKHEAD
8	FRONT BULKHEAD
9	FRONT BULKHEAD
10	FRONT BULKHEAD
11	FRONT BULKHEAD
12	FRONT BULKHEAD
13	FRONT BULKHEAD
14	FRONT BULKHEAD
15	FRONT BULKHEAD
16	FRONT BULKHEAD
17	FRONT BULKHEAD
18	FRONT BULKHEAD
19	FRONT BULKHEAD
20	FRONT BULKHEAD

NO.	REV.	DESCRIPTION	DATE
1		ISSUED FOR PRODUCTION	
2		ISSUED FOR PRODUCTION	
3		ISSUED FOR PRODUCTION	
4		ISSUED FOR PRODUCTION	
5		ISSUED FOR PRODUCTION	
6		ISSUED FOR PRODUCTION	
7		ISSUED FOR PRODUCTION	
8		ISSUED FOR PRODUCTION	
9		ISSUED FOR PRODUCTION	
10		ISSUED FOR PRODUCTION	

NOTES: UNLESS OTHERWISE SPECIFIED
 WITH RUBBER STAMP PART NO. 115377
 WITH WHITE CHARACTERS .12 HIGH COVER WITH MIL-V-13 VARNISH
 ▲ SWIM AS REQUIRED
 ▲ PLACE ITEM 21 BETWEEN SWITCH & BULKHEAD FOR INSULATION

REV	DATE	DESCRIPTION	BY	CHKD
A	10/15/53			
B	10/16/57			
C	10/16/58			
D	10/17/58			
E	10/17/58			
F	10/17/58			

REV	DATE	DESCRIPTION	BY	CHKD
A	10/15/53			
B	10/16/57			
C	10/16/58			
D	10/17/58			
E	10/17/58			
F	10/17/58			

REV	DATE	DESCRIPTION	BY	CHKD
A	10/15/53			
B	10/16/57			
C	10/16/58			
D	10/17/58			
E	10/17/58			
F	10/17/58			

REV	DATE	DESCRIPTION	BY	CHKD
A	10/15/53			
B	10/16/57			
C	10/16/58			
D	10/17/58			
E	10/17/58			
F	10/17/58			

REV	DATE	DESCRIPTION	BY	CHKD
A	10/15/53			
B	10/16/57			
C	10/16/58			
D	10/17/58			
E	10/17/58			
F	10/17/58			

REV	DATE	DESCRIPTION	BY	CHKD
A	10/15/53			
B	10/16/57			
C	10/16/58			
D	10/17/58			
E	10/17/58			
F	10/17/58			

REV	DATE	DESCRIPTION	BY	CHKD
A	10/15/53			
B	10/16/57			
C	10/16/58			
D	10/17/58			
E	10/17/58			
F	10/17/58			



QTY	SYM	DESCRIPTION	UNIT	QTY
2	1	FISH PAPER		26
2	2	LOCK WASHER SPLIT	# 6	24
1	1	BUCKET SWITCH	1125171	23
3	3	SCREW, SOC. HD. CAP	#10-32 X 3/8	22
2	2	SCREW, SOC. HD. CAP	#10-32 X 1.00	21
3	3	SCREW, SOC. HD. CAP	1/4-20 X 3/4	20
2	2	SCREW, PAN. HD.	# 6-32 X 1/2	19
15	15	WASHER, SPLIT LK.	# 10	18
3	3	WASHER, SPLIT LK.	1/4 CLEAR	17
2	2	WASHER, FLAT	# 6	15
4	4	WASHER, FLAT	#10 CLEAR	13
2	2	WASHER, BELLVILLE	6008-8500	12
2	2	BUSHING, FLANGED	4565-0370	11
1	1	SWITCH	2952-1211	10
2	2	CON. SMT. ASSY	1125045	9
1	1	CTR. BULKHD. MACH.	1144975	8
1	1	MIRROR ASSEMBLY	1141650	7
1	1	LANTER ASSEMBLY	1145000	6
1	1	FOCUS TUBE ASSY	1135074	5
1	1	FOCUS TUBE ASSY	1231887	4
1	1	FOCUS TUBE ASSY	XVF LAMP	3
1	1	FOCUS TUBE ASSY	1145043	2

QTY	SYM	DESCRIPTION	UNIT	QTY
2	2	CON. SMT. ASSY	1125045	9
1	1	CTR. BULKHD. MACH.	1144975	8
1	1	MIRROR ASSEMBLY	1141650	7
1	1	LANTER ASSEMBLY	1145000	6
1	1	FOCUS TUBE ASSY	1135074	5
1	1	FOCUS TUBE ASSY	1231887	4
1	1	FOCUS TUBE ASSY	XVF LAMP	3
1	1	FOCUS TUBE ASSY	1145043	2

QTY	SYM	DESCRIPTION	UNIT	QTY
2	2	CON. SMT. ASSY	1125045	9
1	1	CTR. BULKHD. MACH.	1144975	8
1	1	MIRROR ASSEMBLY	1141650	7
1	1	LANTER ASSEMBLY	1145000	6
1	1	FOCUS TUBE ASSY	1135074	5
1	1	FOCUS TUBE ASSY	1231887	4
1	1	FOCUS TUBE ASSY	XVF LAMP	3
1	1	FOCUS TUBE ASSY	1145043	2

QTY	SYM	DESCRIPTION	UNIT	QTY
2	2	CON. SMT. ASSY	1125045	9
1	1	CTR. BULKHD. MACH.	1144975	8
1	1	MIRROR ASSEMBLY	1141650	7
1	1	LANTER ASSEMBLY	1145000	6
1	1	FOCUS TUBE ASSY	1135074	5
1	1	FOCUS TUBE ASSY	1231887	4
1	1	FOCUS TUBE ASSY	XVF LAMP	3
1	1	FOCUS TUBE ASSY	1145043	2

QTY	SYM	DESCRIPTION	UNIT	QTY
2	2	CON. SMT. ASSY	1125045	9
1	1	CTR. BULKHD. MACH.	1144975	8
1	1	MIRROR ASSEMBLY	1141650	7
1	1	LANTER ASSEMBLY	1145000	6
1	1	FOCUS TUBE ASSY	1135074	5
1	1	FOCUS TUBE ASSY	1231887	4
1	1	FOCUS TUBE ASSY	XVF LAMP	3
1	1	FOCUS TUBE ASSY	1145043	2

QTY	SYM	DESCRIPTION	UNIT	QTY
2	2	CON. SMT. ASSY	1125045	9
1	1	CTR. BULKHD. MACH.	1144975	8
1	1	MIRROR ASSEMBLY	1141650	7
1	1	LANTER ASSEMBLY	1145000	6
1	1	FOCUS TUBE ASSY	1135074	5
1	1	FOCUS TUBE ASSY	1231887	4
1	1	FOCUS TUBE ASSY	XVF LAMP	3
1	1	FOCUS TUBE ASSY	1145043	2

STAMP PART NUMBER 1145043 WITH APPROPRIATE DASH NUMBER APPROXIMATELY WHERE SHOWN.

1. ASSEMBLE PER ORC WORKMANSHIP MANUAL STANDARDS.

REV	DATE	DESCRIPTION	BY	APP'D
1	10/15/57	REVISED	WJ	WJ
2	10/15/57	REVISED	WJ	WJ
3	10/15/57	REVISED	WJ	WJ
4	10/15/57	REVISED	WJ	WJ
5	10/15/57	REVISED	WJ	WJ
6	10/15/57	REVISED	WJ	WJ
7	10/15/57	REVISED	WJ	WJ
8	10/15/57	REVISED	WJ	WJ

USE BELDEN WIRE NO. 8899 FROM TERMINAL #1 ON T-2 TO SG-1 AND FROM TERMINAL #2 ON T-2 TO GROUND

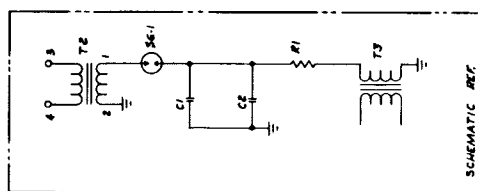

- NOTES:
- 1 THE STAMP IN 1145000 IN AREA SHOWN.
 - 2 ASSEMBLY PER OTC WORKMANSHIP MANUAL STANDARDS.
 - 3 TERMINAL NOS. IDENTIFIED BY (C)
 - 4 USE UL APPROVED TERMINAL LUGS.
 - 5 FOR ASSEMBLY STAR WASHERS ADD NO. 4000 AND BELOW CAPACITOR (2 RACES).
 - 6 DO NOT INSTALL R.P. TRANSFORMER WITH SCREEN IN LOWER HOLE DIRECTLY BEHIND TERMINAL 3.

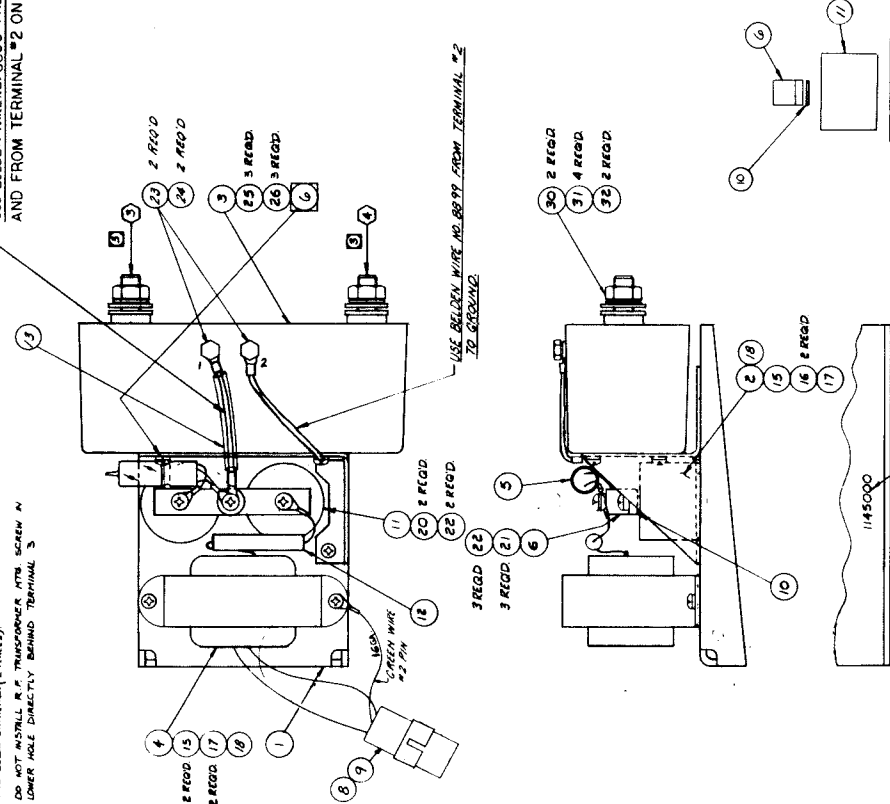

QTY	ITEM	DESCRIPTION	UNIT	FORM NO.
2	WASHER, LOCK	3/8	BRASS	32
2	WASHER, FLAT	3/8	BRASS	31
2	NUT, HEX	3/8-16	BRASS	30
				29
				28
				27
3	WASHER, LOCK	#10		26
3	SCREW, PAN. HD.	10-32x 1/2		25
2	WASHERS, INT. STAR	#10	BRASS	24
2	SCREW, INT. STAR	10-32x 3/8	BRASS	23
7	WASHER, LOCK	#8		22
3	SCREW, PAN. HD.	8-32x 3/8		21
2	SCREW, PAN. HD.	8-32x 1/4		20
3	WASHER, LOCK	#8		19
3	WASHER, FLAT	#8		18
2	WASHER, LOCK	8-32x 3/8		17
2	WASHER, FLAT	8-32x 3/8		16
3	SCREW, PAN. HD.	6-32x 3/4		15
				14
1	TIGON TUBING	1/2x 1/2		13
1	RESISTOR	2555-5035	50K/1W	12
2	CAPACITOR	2201-5701	1000UF/50V	11
1	BUSS BAR	2292-300	5002-2-17	10
2	PINS	1190-A4		9
1	CONNECTOR	1370-P		8
1	INSULATOR SPRNG GAP	1116B1		7
1	SPARK GAP ASSY	1122349		6
1	TRANSFORMER	111813-1		5
1	T.K. TRANSFORMER BRKT.	1148296		4
1	TRANSFORMER BRKT.	1134997		3
1	PLATFORM MOUNT	1134999		2
1	MANUFACTURE OR DESCRIPTION			1

QTY	ITEM	DESCRIPTION	UNIT	FORM NO.
1	WASHER, LOCK	3/8	BRASS	32
1	WASHER, FLAT	3/8	BRASS	31
1	NUT, HEX	3/8-16	BRASS	30
				29
				28
				27
3	WASHER, LOCK	#10		26
3	SCREW, PAN. HD.	10-32x 1/2		25
2	WASHERS, INT. STAR	#10	BRASS	24
2	SCREW, INT. STAR	10-32x 3/8	BRASS	23
7	WASHER, LOCK	#8		22
3	SCREW, PAN. HD.	8-32x 3/8		21
2	SCREW, PAN. HD.	8-32x 1/4		20
3	WASHER, LOCK	#8		19
3	WASHER, FLAT	#8		18
2	WASHER, LOCK	8-32x 3/8		17
2	WASHER, FLAT	8-32x 3/8		16
3	SCREW, PAN. HD.	6-32x 3/4		15
				14
1	TIGON TUBING	1/2x 1/2		13
1	RESISTOR	2555-5035	50K/1W	12
2	CAPACITOR	2201-5701	1000UF/50V	11
1	BUSS BAR	2292-300	5002-2-17	10
2	PINS	1190-A4		9
1	CONNECTOR	1370-P		8
1	INSULATOR SPRNG GAP	1116B1		7
1	SPARK GAP ASSY	1122349		6
1	TRANSFORMER	111813-1		5
1	T.K. TRANSFORMER BRKT.	1148296		4
1	TRANSFORMER BRKT.	1134997		3
1	PLATFORM MOUNT	1134999		2
1	MANUFACTURE OR DESCRIPTION			1

QTY	ITEM	DESCRIPTION	UNIT	FORM NO.
1	WASHER, LOCK	3/8	BRASS	32
1	WASHER, FLAT	3/8	BRASS	31
1	NUT, HEX	3/8-16	BRASS	30
				29
				28
				27
3	WASHER, LOCK	#10		26
3	SCREW, PAN. HD.	10-32x 1/2		25
2	WASHERS, INT. STAR	#10	BRASS	24
2	SCREW, INT. STAR	10-32x 3/8	BRASS	23
7	WASHER, LOCK	#8		22
3	SCREW, PAN. HD.	8-32x 3/8		21
2	SCREW, PAN. HD.	8-32x 1/4		20
3	WASHER, LOCK	#8		19
3	WASHER, FLAT	#8		18
2	WASHER, LOCK	8-32x 3/8		17
2	WASHER, FLAT	8-32x 3/8		16
3	SCREW, PAN. HD.	6-32x 3/4		15
				14
1	TIGON TUBING	1/2x 1/2		13
1	RESISTOR	2555-5035	50K/1W	12
2	CAPACITOR	2201-5701	1000UF/50V	11
1	BUSS BAR	2292-300	5002-2-17	10
2	PINS	1190-A4		9
1	CONNECTOR	1370-P		8
1	INSULATOR SPRNG GAP	1116B1		7
1	SPARK GAP ASSY	1122349		6
1	TRANSFORMER	111813-1		5
1	T.K. TRANSFORMER BRKT.	1148296		4
1	TRANSFORMER BRKT.	1134997		3
1	PLATFORM MOUNT	1134999		2
1	MANUFACTURE OR DESCRIPTION			1

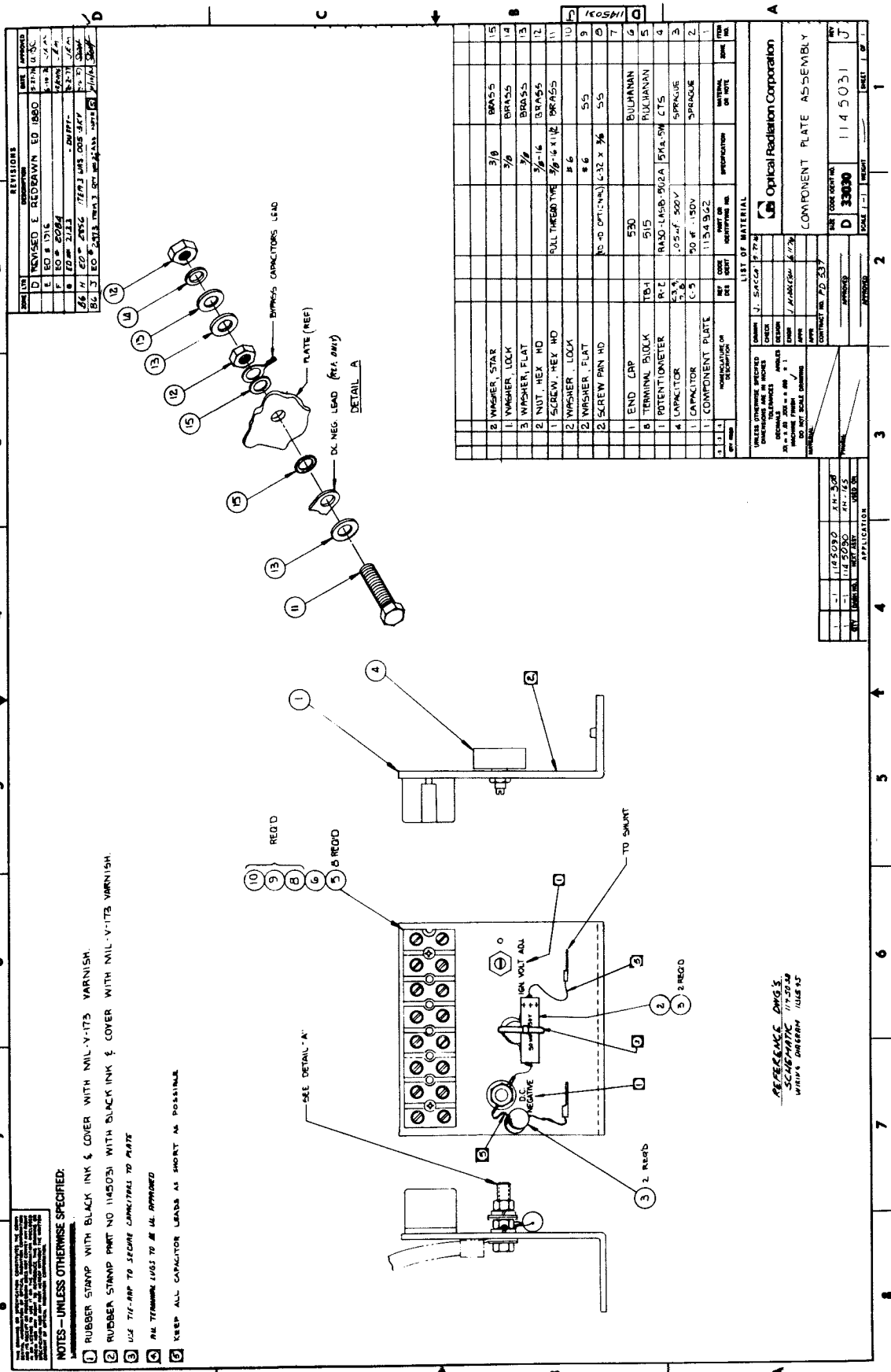

NOTES - UNLESS OTHERWISE SPECIFIED:

- 1 RUBBER STAMP WITH BLACK INK & COVER WITH NAL-V-173 VARNISH.
- 2 RUBBER STAMP PART NO 1145031 WITH BLACK INK & COVER WITH NAL-V-173 VARNISH.
- 3 USE TIC-AP TO SECURE COMPONENTS TO PLATE
- 4 ALL TERMINALS MUST BE ALL APPROVED
- 5 KEEP ALL CAPACITOR LEADS AS SHORT AS POSSIBLE

REV	DATE	BY	APPROVED
D	11/15/50	E. ROZDRAVN	ED (SBO)
E	11/15/50	E. ROZDRAVN	ED (SBO)
F	11/15/50	E. ROZDRAVN	ED (SBO)
G	11/15/50	E. ROZDRAVN	ED (SBO)
H	11/15/50	E. ROZDRAVN	ED (SBO)
I	11/15/50	E. ROZDRAVN	ED (SBO)
J	11/15/50	E. ROZDRAVN	ED (SBO)
K	11/15/50	E. ROZDRAVN	ED (SBO)
L	11/15/50	E. ROZDRAVN	ED (SBO)
M	11/15/50	E. ROZDRAVN	ED (SBO)
N	11/15/50	E. ROZDRAVN	ED (SBO)
O	11/15/50	E. ROZDRAVN	ED (SBO)
P	11/15/50	E. ROZDRAVN	ED (SBO)
Q	11/15/50	E. ROZDRAVN	ED (SBO)
R	11/15/50	E. ROZDRAVN	ED (SBO)
S	11/15/50	E. ROZDRAVN	ED (SBO)
T	11/15/50	E. ROZDRAVN	ED (SBO)
U	11/15/50	E. ROZDRAVN	ED (SBO)
V	11/15/50	E. ROZDRAVN	ED (SBO)
W	11/15/50	E. ROZDRAVN	ED (SBO)
X	11/15/50	E. ROZDRAVN	ED (SBO)
Y	11/15/50	E. ROZDRAVN	ED (SBO)
Z	11/15/50	E. ROZDRAVN	ED (SBO)

QTY	DESCRIPTION	REF	CODE	UNIT OR IDENTIFYING NO.	APPROXIMATE	DATE
2	WASHER, STAR	3/8				
1	WASHER, LOCK	3/8				
3	WASHER, FLAT	3/8				
2	NUT, HEX HD	3/8				
1	SCREW, HEX HD	3/8				
2	WASHER, LOCK	# 6				
2	WASHER, FLAT	# 6				
2	SCREW PAN HD	# 6				
1	END GRP	530				
8	TERMINAL BLOCK	TB-1				
1	POTENTIOMETER	P.C.1				
4	CAPACITOR	5.3, 7.5, 10.5, 15.0				
1	COMPONENT PLATE	C-5				

QTY	DESCRIPTION	REF	CODE	UNIT OR IDENTIFYING NO.	APPROXIMATE	DATE
1	BYWEG'S CAPACITORS LEAD					
1	DC NEG LEAD (REF. ONLY)					
1	PLATE (REF)					

QTY	DESCRIPTION	REF	CODE	UNIT OR IDENTIFYING NO.	APPROXIMATE	DATE
1	WASHER, STAR	3/8				
1	WASHER, LOCK	3/8				
3	WASHER, FLAT	3/8				
2	NUT, HEX HD	3/8				
1	SCREW, HEX HD	3/8				
2	WASHER, LOCK	# 6				
2	WASHER, FLAT	# 6				
2	SCREW PAN HD	# 6				
1	END GRP	530				
8	TERMINAL BLOCK	TB-1				
1	POTENTIOMETER	P.C.1				
4	CAPACITOR	5.3, 7.5, 10.5, 15.0				
1	COMPONENT PLATE	C-5				

QTY	DESCRIPTION	REF	CODE	UNIT OR IDENTIFYING NO.	APPROXIMATE	DATE
1	BYWEG'S CAPACITORS LEAD					
1	DC NEG LEAD (REF. ONLY)					
1	PLATE (REF)					

QTY	DESCRIPTION	REF	CODE	UNIT OR IDENTIFYING NO.	APPROXIMATE	DATE
1	BYWEG'S CAPACITORS LEAD					
1	DC NEG LEAD (REF. ONLY)					
1	PLATE (REF)					

REVISIONS

APPROVED: _____

DATE: _____

SCALE: 1:1

FIG. NO. 114 5031

COMPONENT PLATE ASSEMBLY

Optical Radiation Corporation

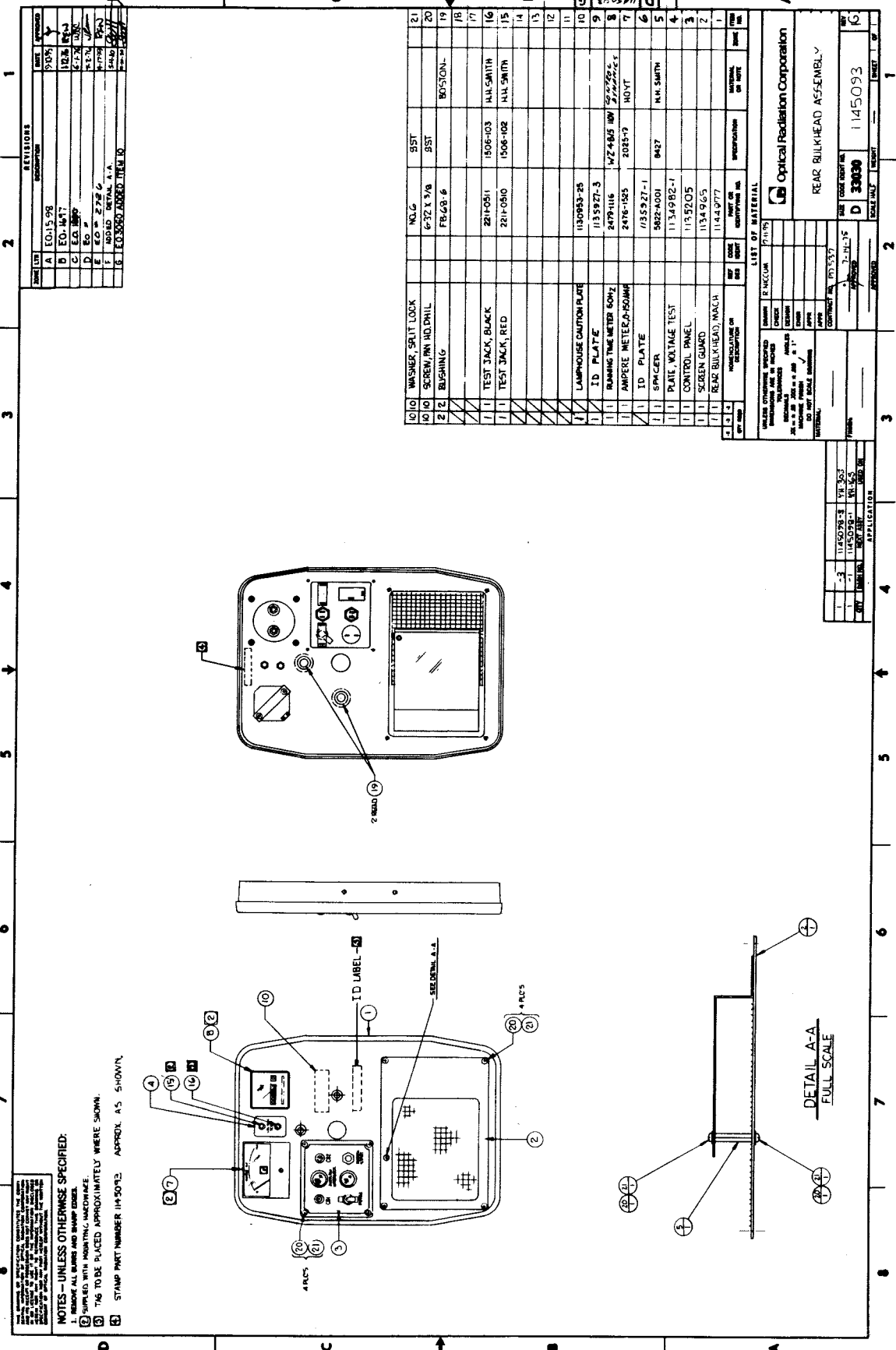

NOTES—UNLESS OTHERWISE SPECIFIED:
 1. REMOVE ALL BARRS AND BRASS EXCEL.
 2. SUPPLIED WITH MOUNTING WACOWACE.
 3. TAG TO BE PLACED APPROXIMATELY WHERE SHOWN.
 4. STAMP PART NUMBER IH-5012 APPROX. AS SHOWN.

ITEM NO.	QUANTITY	DESCRIPTION	DATE APPROVED
1	1	EQ-15 9R	9/5/50
2	1	EQ-1417	10/2/50
3	1	EQ-1418	11/2/50
4	1	EQ-1419	11/2/50
5	1	EQ-1420	11/2/50
6	1	EQ-1421	11/2/50
7	1	EQ-1422	11/2/50
8	1	EQ-1423	11/2/50

QTY	DESCRIPTION	PART NO.	QUANTITY	DATE APPROVED	APPROVED BY
1	WASHER, SLIT LOCK	6-32 X 3/8	1	10/15/50	H. H. SMITH
1	SCREW, PH. HD. DRILL	FE-68-6	1	10/15/50	H. H. SMITH
1	BUSHING		1	10/15/50	H. H. SMITH
1	TEST JACK, BLACK	221-0511	1	10/15/50	H. H. SMITH
1	TEST JACK, RED	221-0510	1	10/15/50	H. H. SMITH
1	LAMPHOUSE CAUTION PLATE	1130953-25	1	10/15/50	H. H. SMITH
1	ID PLATE	1135927-3	1	10/15/50	H. H. SMITH
1	ROTTING TIME METER GONZ	2479-116	1	10/15/50	H. H. SMITH
1	AMPERE METER, A-500MHP	2476-185	1	10/15/50	H. H. SMITH
1	ID PLATE	1135927-1	1	10/15/50	H. H. SMITH
1	SPACER	5822-1001	1	10/15/50	H. H. SMITH
1	PLATE, VOLTAGE TEST	1134982-1	1	10/15/50	H. H. SMITH
1	CONTROL PANEL	1135205	1	10/15/50	H. H. SMITH
1	SCREEN GUARD	1134965	1	10/15/50	H. H. SMITH
1	REAR BULK HEAD, MACH.	1144977	1	10/15/50	H. H. SMITH

LIST OF MATERIAL

Optical Radiation Corporation
 REAR BULK HEAD ASSEMBLY

QTY: 1
 DATE: 10/15/50
 DRAWING NO.: 1145093
 PART NO.: 33030

THIS DRAWING OR SPECIFICATION CONSTITUTES THE COMPLETE INFORMATION OF OPTICAL RADIATION CORPORATION AND IS NOT TO BE REPRODUCED OR TRANSMITTED IN ANY FORM OR BY ANY MEANS, ELECTRONIC OR MECHANICAL, INCLUDING PHOTOCOPYING, RECORDING, OR BY ANY INFORMATION STORAGE AND RETRIEVAL SYSTEM, WITHOUT THE WRITTEN CONSENT OF OPTICAL RADIATION CORPORATION.

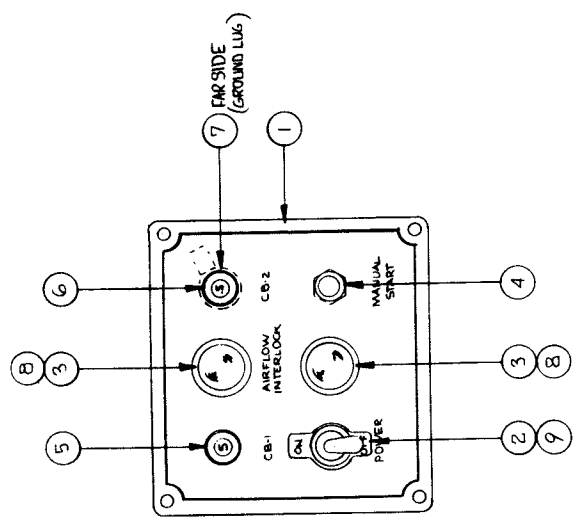

REVISIONS			
ZONE LTR	DESCRIPTION	DATE	APPROVED
A	E.O. 1680	5-17-76	[Signature]
B	2227	6-1-77	[Signature]

QTY	REQD	1	2	3	4	5	6	7	8	9
1	1	INDICATOR PLATE	-	Y O I						CHARLINGS WIRTH
2	1	LAMP	-	B2-A	120V					G-E
1	1	LUG	-	TN 18-3-B	3/8 LUG					BIRNBY CORP
1	1	CIRCUIT BREAKER	CB2	45-700-P	.5 AMP					ETA
1	1	CIRCUIT BREAKER	CB1	45-700-P	.5 AMP					ETA
1	1	PUSH BUTTON SW.	S-2	3DO5-5P						ROBERT SHAW
2	1	INDICATOR LIGHT	DS-1	95-0463-0931-331						DIALCO
1	1	SWITCH, TOGGLE	S-1	82600	SPST					ARROW HART
1	1	CONTROL PANEL	-	1134980						

LIST OF MATERIAL

UNLESS OTHERWISE SPECIFIED DIMENSIONS ARE IN INCHES	DECIMALS	ANGLES	DESIGN
XX ± .03	XXX ± .010	± 1/2°	✓
MACHINE FINISH			
DO NOT SCALE DRAWING			
MATERIAL:			
CONTRACT NO. PD 557			
APPROVED			
DATE 1/11/75			

Optical Radiation Corporation

CONTROL PANEL ASSY.

SIZE	CODE IDENT NO.	REV.
C	33030	8
SCALE	FULL	WEIGHT
		SHEET 1 OF 1

QTY	DASH NO.	APPLICATION
1	1145093	XI-30B
1	1145093	XI-169
1	1145093	USED ON
1	1145093	NEXT ASSY

ORC

ORC Lighting Products
1300 Optical Drive
Azusa, Calif. 91702
1-800-755-LAMP
(626) 815-3100
fax: 626-815-3074

Order parts from:
Strong International
4350 McKinley St.
Omaha, Neb. 68112
1-800-424-1215
(402) 453-4444
fax: 402-453-7238
www.strong-cinema.com