

FILM-TECH

THE INFORMATION CONTAINED IN THIS ADOBE ACROBAT PDF FILE IS PROVIDED AT YOUR OWN RISK AND GOOD JUDGMENT.

THESE MANUALS ARE DESIGNED TO FACILITATE THE EXCHANGE OF INFORMATION RELATED TO CINEMA PROJECTION AND FILM HANDLING, WITH NO WARRANTIES NOR OBLIGATIONS FROM THE AUTHORS, FOR QUALIFIED FIELD SERVICE ENGINEERS.

IF YOU ARE NOT A QUALIFIED TECHNICIAN, PLEASE MAKE NO ADJUSTMENTS TO ANYTHING YOU MAY READ ABOUT IN THESE ADOBE MANUAL DOWNLOADS.

WWW.FILM-TECH.COM

2C8-41.01

RCA PHOTOPHONE
Type PG-139

HIGH FIDELITY
THEATRE SOUND REPRODUCING
EQUIPMENT

EXHIBITOR'S INSTALLATION
INSTRUCTIONS

THIRD EDITION
JULY 1939

PHOTOPHONE DIVISION

RCA Manufacturing Company, Inc.

Camden, N. J., U. S. A.

A SERVICE OF THE RADIO CORPORATION OF AMERICA

FOREWORD



EXHIBITOR - PLEASE READ CAREFULLY FOR YOUR PROTECTION

This instruction book covers the procedure to be followed by the exhibitor in connection with the installation of the RCA Type PG-139 sound motion picture equipment in the theatre.

In order to avoid delay and added expense, the exhibitor must complete this work prior to the arrival of the RCA Photophone Installation Engineer. Such work is to be done at the exhibitor's expense and responsibility, and the RCA Manufacturing Company, Inc., assumes no responsibility for any expense involved in the event the conditional sales contract is unacceptable to the Company.

ONE CALL OF TWO SUCCESSIVE DAYS OF EIGHT HOURS each will be made by the RCA Photophone Engineer to supervise the completion and final test of the equipment. Should it be necessary, because of incomplete preliminary installation work, for our Engineer to spend more than the allotted two days of eight hours each, the cost of this additional time will be billed at our current rates.

The exhibitor should communicate with the RCA Manufacturing Company, Inc., District Service Supervisor, to obtain approval of any deviations from the instructions contained herein.

To the RCA Manufacturing Company, Inc., District Service Manager:

This will acknowledge receipt of the Installation Instructions for the PG-139 Equipment for which I have signed a Conditional Sales Contract. I understand that the RCA Manufacturing Company, Inc., assumes no responsibility for any expense involved in the execution of these instructions when the Conditional Sales Contract is unacceptable to the Company.

EXHIBITOR

Date.....

THEATRE

LOCATION

RCA Manufacturing Co., Inc., Sales Representative

This Sheet must be detached and mailed to the RCA Manufacturing Company, Inc., District Service Manager by the Sales Representative.

PG-139

INSTALLATION INSTRUCTIONS

EQUIPMENT

The equipment will be delivered packed in wooden cases and cartons. The outside of each case or carton is plainly marked with the Master Item (MI) number which has been assigned to each collection of parts which form one of the units or assemblies into which the equipment has been broken down for shipment. The contents of cases bearing the same Master Item number are identical in every respect and are interchangeable. As an aid in checking the equipment, each case of RCA Photophone equipment will contain a factory list of its contents. These packing lists and the inspection tags removed from each unit should be retained and given to the RCA Photophone Engineer upon his arrival.

Such Master Items only as are listed below should be unpacked and these only as their installation is required, in a location as convenient as possible to that which they will finally occupy.

All other cases or cartons, marked "TO BE OPENED ONLY BY RCA MANUFACTURING COMPANY REPRESENTATIVES" should be kept in a safe place and unpacked under the supervision of the RCA Photophone Engineer only.

The installation work which the exhibitor *must* complete before the RCA Photophone Engineer arrives at the theatre is as follows:

- (1) Unpack and install the amplifier cabinet (MI-9315).
- (2) Unpack and install the power supply unit (MI-9520).
- (3) Unpack and install the sound control units (MI-92C2).
- (4) Unpack and install the monitor loudspeaker (MI-14C5).
- (5) Complete all conduit and electrical wiring specified herein.
- (6) "Ring out" and tag all conductors.
- (7) Construct the stage loudspeaker rack or platform and mount the loudspeaker baffles (MI-9457 and MI-9485-6- or 7).

The suggested locations of these units are shown in Figure 1.

It must be borne in mind that while the equipment is of sturdy construction, it is, nevertheless, sensitive electrical apparatus, and care must therefore be taken that unpacked equipment is not left exposed to damage during installation.

MATERIAL

A list of suggested material, which the electrical contractor will be required to furnish is shown in the following tabulation. This list is approximate only and should merely serve as a guide in determining the actual material needed.

Electrical contractors use a variety of fittings, such as junction boxes, condulets, etc.; therefore, the type and number of fittings, conduits, etc., is entirely optional, and should be estimated from the installation plans and suggested material list.

TO BE FURNISHED BY EXHIBITOR

ITEM	QUANTITY	MATERIAL
1	1	30-ampere, double pole, single throw switch with pilot lamp such as Trumbull No. 5791 or similar.
2	1	30-ampere, double pole, single throw switch with pilot lamp such as Trumbull No. 13640 (no fuse) or similar.
3	1	Steel cabinet, Type "A," 6" x 9" x 4" for mounting fuse cutout.
4	1	G.E. 62587 two-wire, double branch fuse plug cutout, or similar,
5	1	DPDT switch, such as G.E. 289739 or similar.
6	1	G. E. Fuse Block 62965 or similar.
7	1	Conduit box suitable for Items 5 and 6..
***8	6	15-ampere plug fuses,
9		Miscellaneous 3-1/4" or 4" junction boxes and covers or fittings.
*10		Conduit - 10 ft. lengths,
*11		1/2" and 3/4" Greenfield (flexible conduit).
12		Miscellaneous locknuts and bushings for conduit and Greenfield connectors.
**13		Condulets.
*14		No. 14 single conductor - rubber covered - braided wire (BRC).
*15		No. 12 single conductor - rubber covered- braided wire (BRC).
*16		No. 14 flame-proof wire (for exciter lamp supply).
*17		4-wire No. 14 Tirez stage cable or similar.
*18		5-wire No. 14 Tirez stage cable or similar.
19		Lumber for stage loudspeaker rack or platform.
20		1/4" bolts for mounting amplifier on wall.
21	1	Oval pipe floor flange for 3/4" pipe for mounting monitor speaker, G.E. Cat. No. 14C3578 or similar.
22	1	Length of 3/4" pipe for mounting monitor speaker.
23	1	Type "C" condulet for 1/2" conduit with one hole porcelain cover.
24	1	Sound screen (see list of approved screens).

*NOTE No. 1 - The number of lengths of conduit and the amount of wire required will depend on the size of projection room and theatre, and the location of the equipment. Before ordering any material, study carefully the drawings and sketches in this instruction booklet and then determine just how much material will be necessary.

**NOTE No. 2 - The number of condulets will depend on the number of bends required in the various conduit runs. While the use of condulets is recommended so that wires may be more readily pulled through conduit, it is permissible to make bends in the conduit, providing no more than four 90-degree bends are made in a single run.

***NOTE No. 3 - "Fusetron" fuses are recommended for protection of the sound-head drive motors. 4-ampere "Fusetrons" should be used in the motor circuit if used in place of the standard fuse sizes shown in the drawings.

THEATRE ACOUSTICS

Sound reproduction is directly affected by the acoustical conditions of the theatre auditorium. Therefore, to obtain the optimum results from the equipment, it is important that the theatre have the proper reverberation time for its size and have all reflecting surfaces constructed or treated to reduce possibility of echo.

The services of the Engineering Division of RCA Manufacturing Company, Inc., are available to architects, for acoustic analysis and recommended treatment of proposed new theatres and theatres under construction. Requests for this service should be made through the local RCA District Office, and should be accompanied by a complete set of building plans.

APPROVED SOUND SCREENS

The following manufacturers have submitted samples of sound screens which have been tested and found satisfactory (for acoustic qualities only) in accordance with the S.M.P.E. standards, and are therefore approved by the RCA Photophone Engineering Department for use with RCA Photophone High Fidelity Reproducing Equipment:

Dalite Datone	Dalite Datone Z	Dalite Screen Co., 2715 N. Crawford Ave., Chicago, Ill
*Ortho-Krome		Ortho-Krome Screen Co., Salisbury, Md.
*Raven Metatone	*Raven Transtone A	Raven Screen Corp., 1476 Broadway, New York, N.Y.
Raven Transtone	*Raven Flameproof	
Raytone Flameproof		Raytone Screen Company, 73 Park Ave., Brooklyn, N.Y.
Pearl Screen		
*Perma-Lite	*Audio-Lite	Theatre Screen Corp., Roosevelt, N.Y.
*Chromolite	*Super Vocalite	
Walker Silversheet		Walker-American Corp., St. Louis, Mo.
Walker (Gray Back)		
*Evenlite		Hurley Screen Co., 24-15 43rd Ave., Long Island City, N.Y.
*New Standard		
*WS-15		

To obtain maximum sound quality it is important that only an approved sound screen in good condition be used. Screens marked with asterisk have an attenuation less than 2 decibels at 6000 cycles per second.

NOTE - Since fire regulations vary considerably in the different sections of the country, RCA Manufacturing Company, Inc., does not assume responsibility regarding the flameproof qualities of a particular approved screen. Communicate with your local fire inspector to determine whether or not the chosen sound screen conforms with local fire ordinances.

INSTALLATION

In conjunction with the electrical contractor, check very carefully the installation diagrams in Figures 1 and 2, and plan the equipment locations best suited for the projection room.

The layout shown on the installation diagrams should be followed as closely as possible; however deviation from this layout may be necessary due to existing theatre construction, etc. This is permissible provided the general plan is followed.

In those instances where a new reproducing equipment is to replace an equipment already existing, the exhibitor should check the existing conduit and wiring with the installation drawing, to determine how much of this conduit and wiring can be used again and how much additional wiring is required.

In this connection, we suggest the following items be checked carefully:

- (1) Power supply wiring.
- (2) Conduit and wiring for projector drive motors.
- (3) Conduit and wiring to monitor speaker.
- (4) Conduit and wiring between projection room and stage.

As soon as the equipment arrives at the theatre, check the shipment against the complete packing list which will be received at the same time. Any missing items or discrepancies not noted on the packing list should immediately be brought to the attention of the RCA District Service Supervisor.

Set aside those Master Items or units listed above which the exhibitor is required to install and proceed with the preliminary installation work. **DO NOT WAIT FOR THE RCA PHOTOPHONE ENGINEER TO ARRIVE AT THE THEATRE.** Notify the District Service Supervisor as soon as this preliminary work has been completed.

The work which the exhibitor is called upon to do without supervision does not include the installation and wiring of the soundheads, the installation and wiring of the stage loudspeaker mechanisms and the placing of Radiotrons in the amplifiers and soundheads. This work will be done under the supervision of the RCA Photophone Engineer only.

The major portion of the time allotted to the RCA Photophone Engineer for completion of the installation, should be available for final testing and adjustment of the sound equipment. This is necessary if the final installation is to be satisfactory. Therefore, the importance is again stressed of having all preliminary installation work completed in accordance with the foregoing instructions before the RCA Photophone Engineer arrives on the job.

REAR WALL

NOTE - LOCATION OF POWER SUPPLY UNIT AS SHOWN IS APPROXIMATE. THIS MAY BE RELOCATED TO SUIT PARTICULAR INSTALLATION PROVIDING THERE IS AMPLE VENTILATION.

MI-9520
FIELD & EXC. LAMP SUPPLY

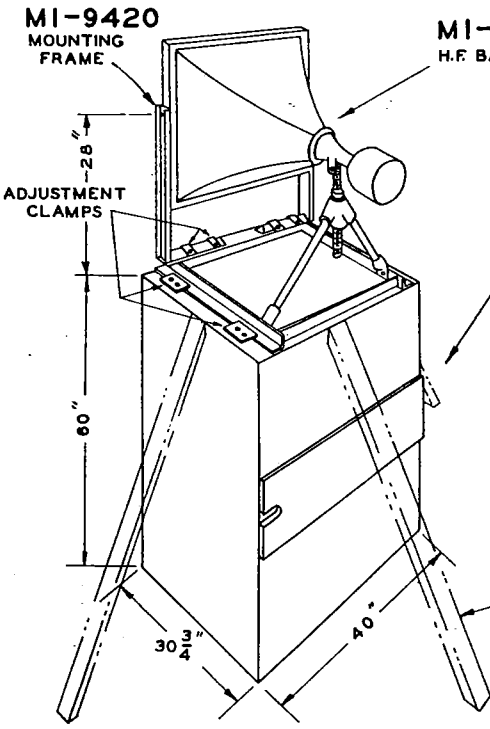
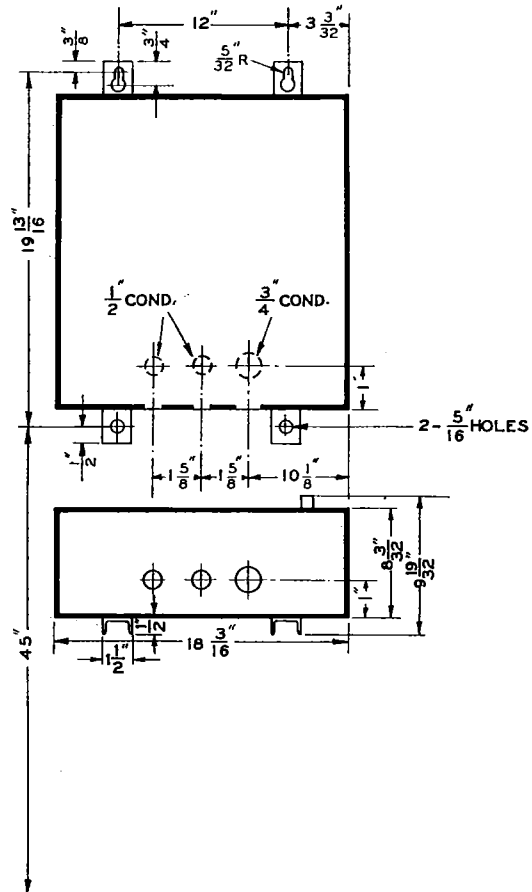

MI-9485-6-7
H.F. BAFFLE

MI-9457
L.F. BAFFLE

NOTE - THE CENTER AXIS OF THE H.F. BAFFLE SHOULD BE 2/3 PICTURE HEIGHT. A PLATFORM TO SUPPORT THE ENTIRE ASSEMBLY AT THIS HEIGHT SHOULD BE CONSTRUCTED BY THE EXHIBITOR.

NOTE - SOME MEANS OF SUPPORTING L.F. BAFFLE STRUCTURE SHOULD BE SUPPLIED BY EXHIBITOR.

PROJECTION ANGLE IN DEGREES	DISTANCE FROM FLOOR TO CENTER LINE OF PROJECTION PORTS FOR VARIOUS ANGLES OF PROJECTION							DISTANCE FROM FLOOR TO CENTER OF OBSERVATION PORT
	DIMENSION "U" INCH							
	SIMPLEX RCA TYPHER PEDESTAL	SIMPLEX ACME	SIMPLEX RCA STANDARD TYPHER	SIMPLEX TELETYPE PEDESTAL	MOTOGRAF	SIMPLEX TELETYPE L & M PEDESTAL		
- 6	51 1/2	51	51	51 1/2	52	51	64	
- 4	50	50	50	50	50	50	63	
- 2	49 1/2	49	49	49 1/2	49	49	62	
0	48	48	48	48	48	48	61	
2	47 1/2	47	47	47 1/2	47	47	60	
4	47	47	46	47	46	46	59	
6	45 1/2	45	45	45 1/2	45	45	58	
8	44	44	44	44	44	44	57	
10	42	43	43	42	42	43	56	
12	40	42 1/2	42	40	41 1/2	42	55	
14	39	41 1/2	41	39	40	41	54	
16	37 1/2	40 1/2	40	37 1/2	38 1/2	40	52	
18	35 1/2	39 1/2	38 1/2	35 1/2	37	38 1/2	51	
20	34	38 1/2	37 1/2	34	35 1/2	37 1/2	50	
22	33	37 1/2	36 1/2	33	33 1/2	36 1/2	50	
24	32	37	35 1/2	32	31	35 1/2	50	
26	31 1/2	36	34	31	30	34	49	

SIDE WALL

FRONT

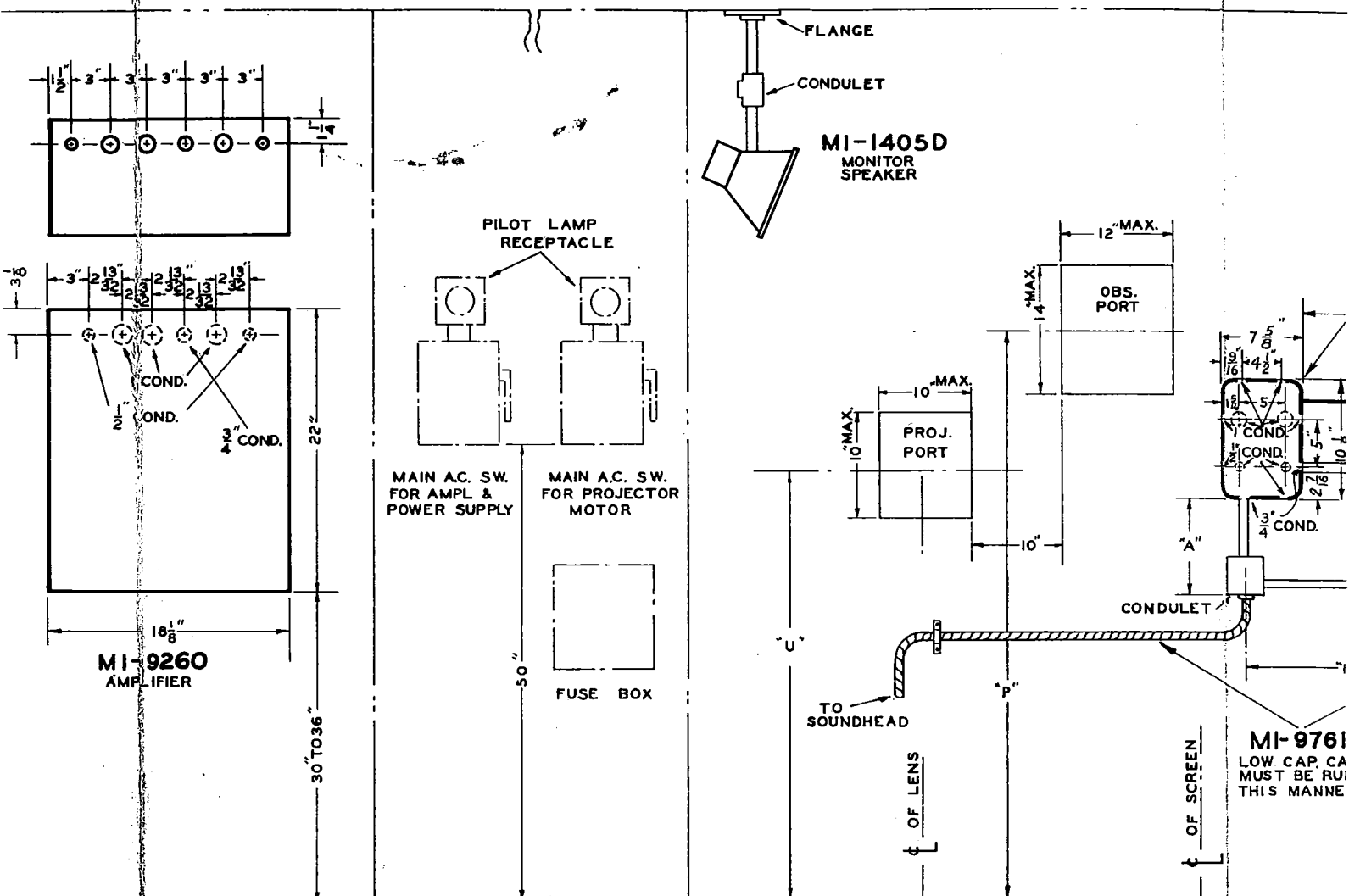

MOTI GRAPH	SIMPLEX SELECT. L & M PEDESTAL	DISTANCE FROM FLOOR TO C. OF OBSERVATION PORT. IN FEET	C. OF OBSERVATION PORT. IN FEET
52	51	64	
50	50	63	
49	49	62	
48	48	61	
47	47	60	
46	46	59	
45	45	58	
44	44	57	
42	43	56	
41 1/2	42	55	
40	41	54	
38 1/2	40	52	
37	38 1/2	51	
35 1/2	37 1/2	50	
33 1/2	36 1/2	50	
31	35 1/2	50	
30	34	49	

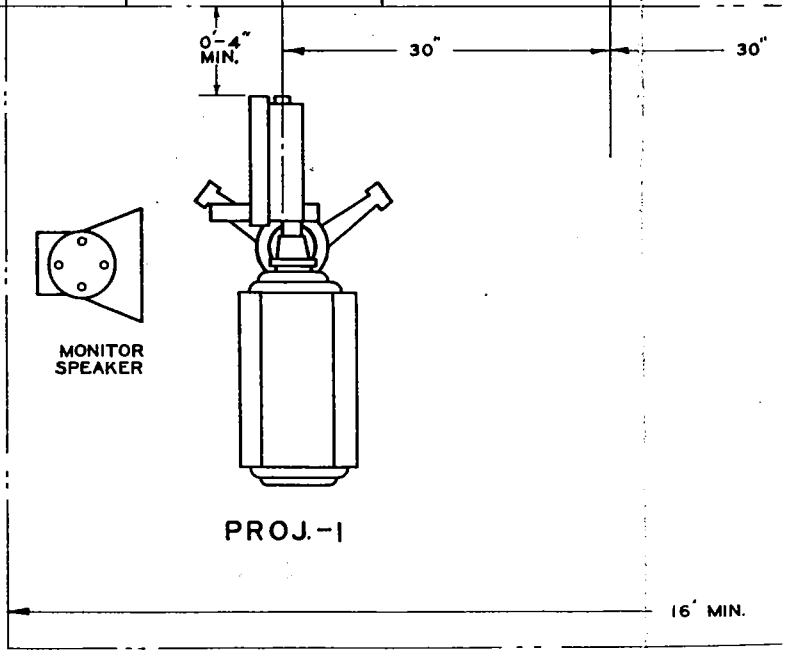
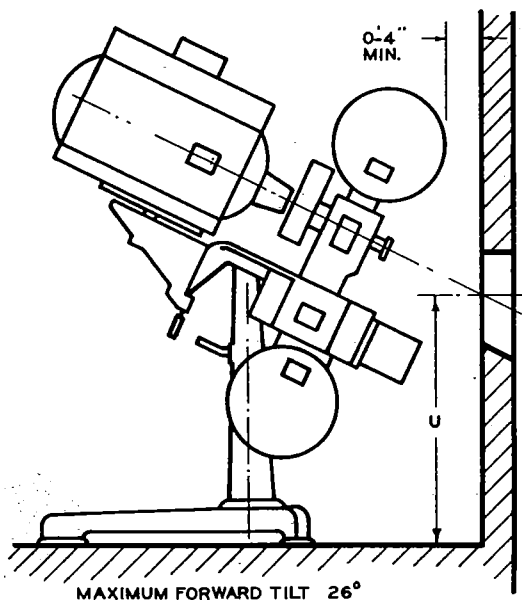

FLOOR PLAN

FRONT WALL

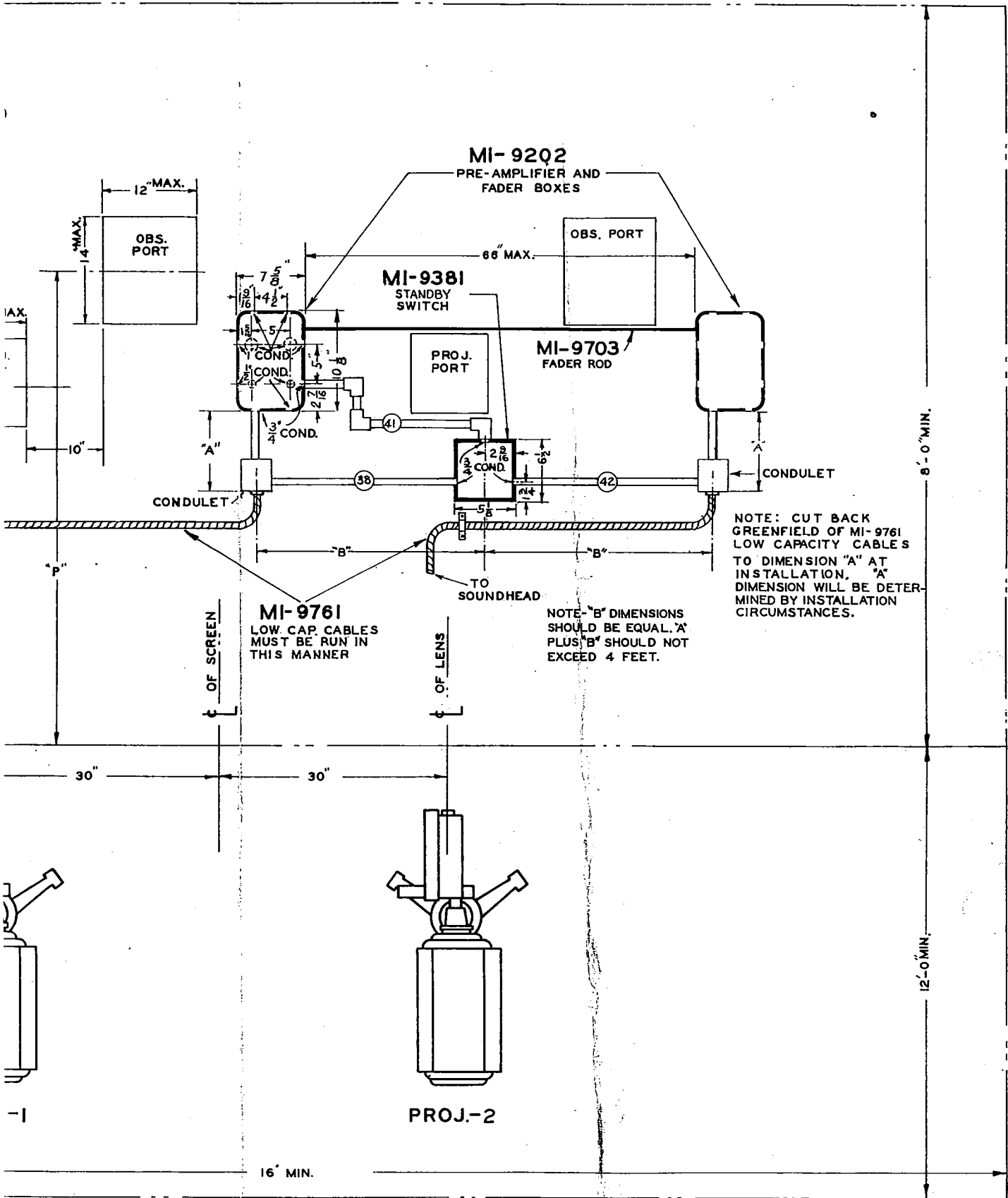

FLOOR PLAN

TT-613059-2

Figure 1 - PG-139 Series Equipment Unit Layout

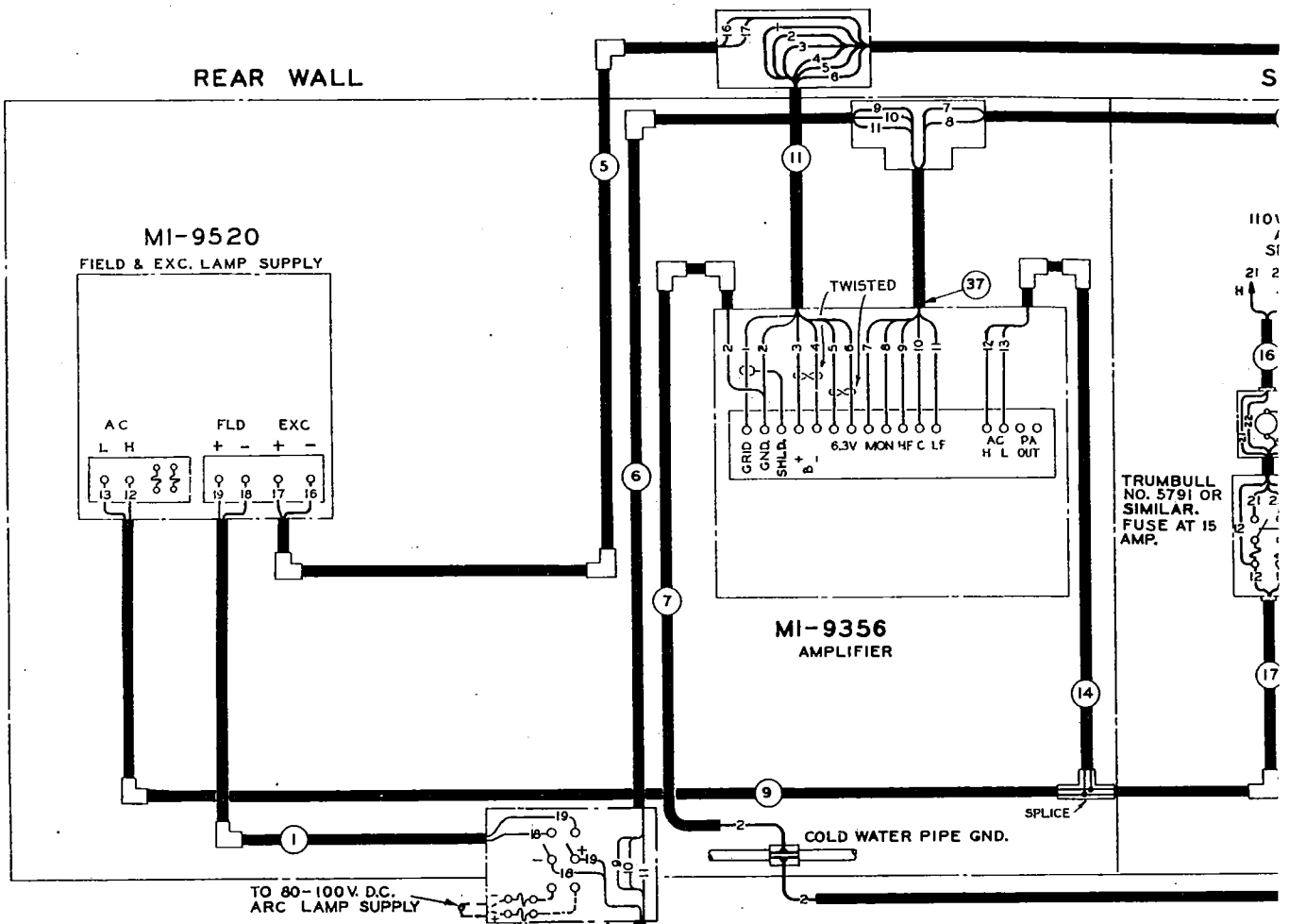

D.P.D.T. SWITCH G.E. NO. 289739, AND FUSE BLOCK G.E. NO. 62965, OR SIMILAR, WITH SUITABLE CONDUIT BOX TO BE SUPPLIED BY THE EXHIBITOR. FUSE 5 AMP.

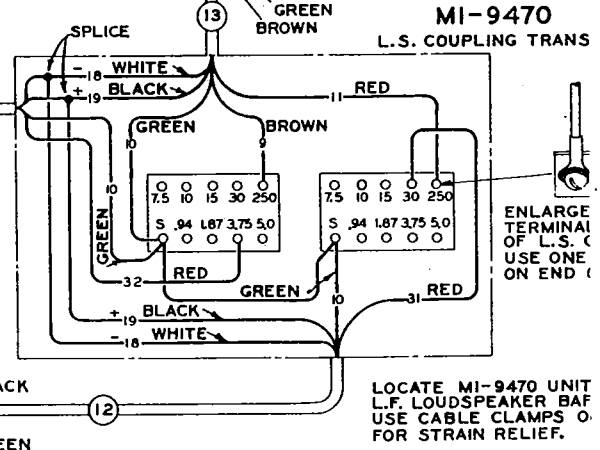
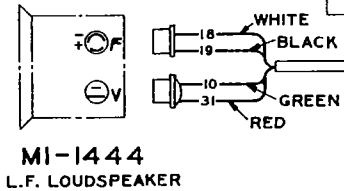
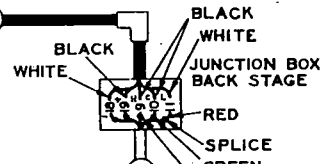
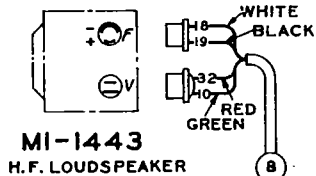

TWO TWO-CONDUCTOR TIREX CAN BE USED IN PLACE OF ONE FOUR-CONDUCTOR CABLE AS SHOWN.

LOCATE MI-9470 UNIT L.F. LOUDSPEAKER BAF USE CABLE CLAMPS OR FOR STRAIN RELIEF.

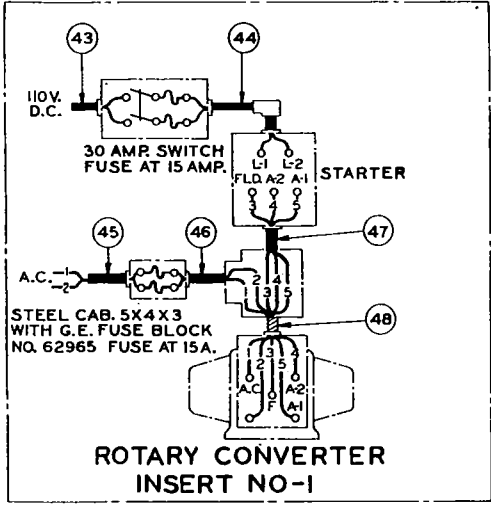
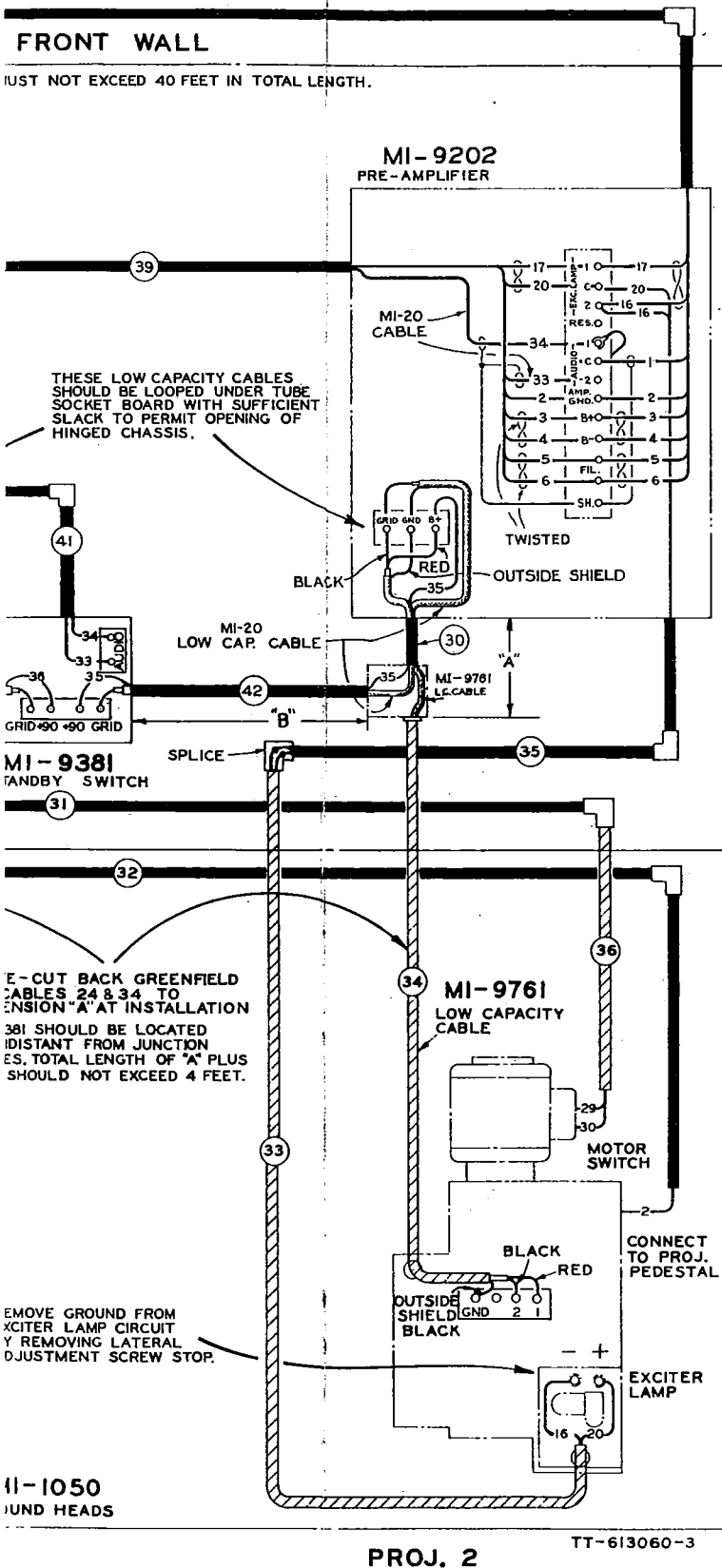

- NOTES**
- MI-20 LOW CAPACITY CABLE FURNISHED BY RCA.
 - B.R.C. INDICATES I-CONDUCTOR WITH RUBBER INSULATION AND SINGLE BRAID COVERING.
 - CONDUIT SIZES SHOWN ARE MINIMUM ALLOWED BY NATIONAL BOARD OF FIRE UNDERWRITERS USE LARGER SIZES IF REQUIRED BY LOCAL ORDINANCE.
 - GROUND ALL PROJECTION ROOM CONDUIT.
 - IF DESIRED FOR MOTOR CIRCUIT OMIT A.C. SWITCH SHOWN & RUN DIRECT TO MAIN A.C. DISTRIBUTION PANEL IN PROJ. ROOM BUT EACH MOTOR CIRCUIT MUST BE SEPARATELY FUSED.
 - POWER SUPPLY UNIT SHOULD BE LOCATED ON REAR OR SIDE WALL OF PROJ. ROOM.
 - SPLICES PERMITTED ONLY AT POINTS SHOWN.
 - CONDUIT FITTINGS ARE SHOWN MERELY TO ILLUSTRATE SUGGESTED METHODS OF CONNECTING. THE ACTUAL NUMBER AND TYPE WILL BE DETERMINED BY PROJ. ROOM CONSTRUCTION AND INSTALLATION CIRCUMSTANCES AND IS LEFT TO THE ELECTRICAL CONTRACTORS DISCRETION.
 - UNDER NO CIRCUMSTANCES SHOULD THE LOW CAPACITY CABLES, MI-9761, BE CUT OR SHORTENED. TAKE UP EXCESS LENGTH BY LOOPING.

CONDUIT TABULATION	
CONDUIT NO.	WIRE AND CONDUIT SIZE
(18)(19)(31)	2 NO. 10 B.R.C. 1/2" COND.
(21)	4 NO. 10 B.R.C. 3/4" COND.
(17)(16)(43)(44)(45)(46)	2 NO. 12 B.R.C. 1/2" COND.
(47)	3 NO. 12 B.R.C. 1/2" COND.
(48)	5 NO. 12 B.R.C. 1" GREENFIELD
(7)(20)(28)(32)	1 NO. 14 B.R.C. 1/2" COND.
(1)(5)(9)(27)(35)	2 NO. 14 B.R.C. 1/2" COND.
(14)(15)	
(6)	3 NO. 14 B.R.C. 1/2" COND.
(10)(37)	5 NO. 14 B.R.C. 3/4" COND.
(23)(33)	2 NO. 14 FLAMEPROOF 1/2" GREENFIELD
(28)(36)	2 NO. 10 B.R.C. 1/2" GREENFIELD
(22)	1 PR. NO. 14 RUBBER COVERED FLEXIBLE
(25)(30)	1 MI-9761 LOW CAPACITY CABLE 1 MI-20 LOW CAPACITY CABLE, SEE NOTE-1 1 NO. 14 B.R.C. FLEXIBLE 3/4" COND.
(41)	2 MI-20 LOW CAP. CABLES 3/4" COND.
(38)(42)	1 MI-20 LOW CAP. CABLE SEE NOTE-1 1 NO. 14 B.R.C. FLEXIBLE 3/4" COND.
(29)	1 MI-20 LOW CAP. CABLE 7 NO. 14 B.R.C. TWISTED IN PAIRS. } 1" COND.
(26)	2 MI-20 LOW CAP. CABLES 7 NO. 14 B.R.C. TWISTED IN PAIRS. } 1" COND.
(24)(34)	LOW CAP. CABLE MI-9761
(8)(12)	4 NO. 14 TIREX OR SIMILAR
(13)	5 NO. 14 TIREX OR SIMILAR
(11)	1 MI-20 LOW CAP. CABLE 5 NO. 14 B.R.C. TWISTED IN PAIRS. } 1" COND.

Figure 2 - PG-139 Equipment Conduit and Wiring Layout

REAR WALL

SD

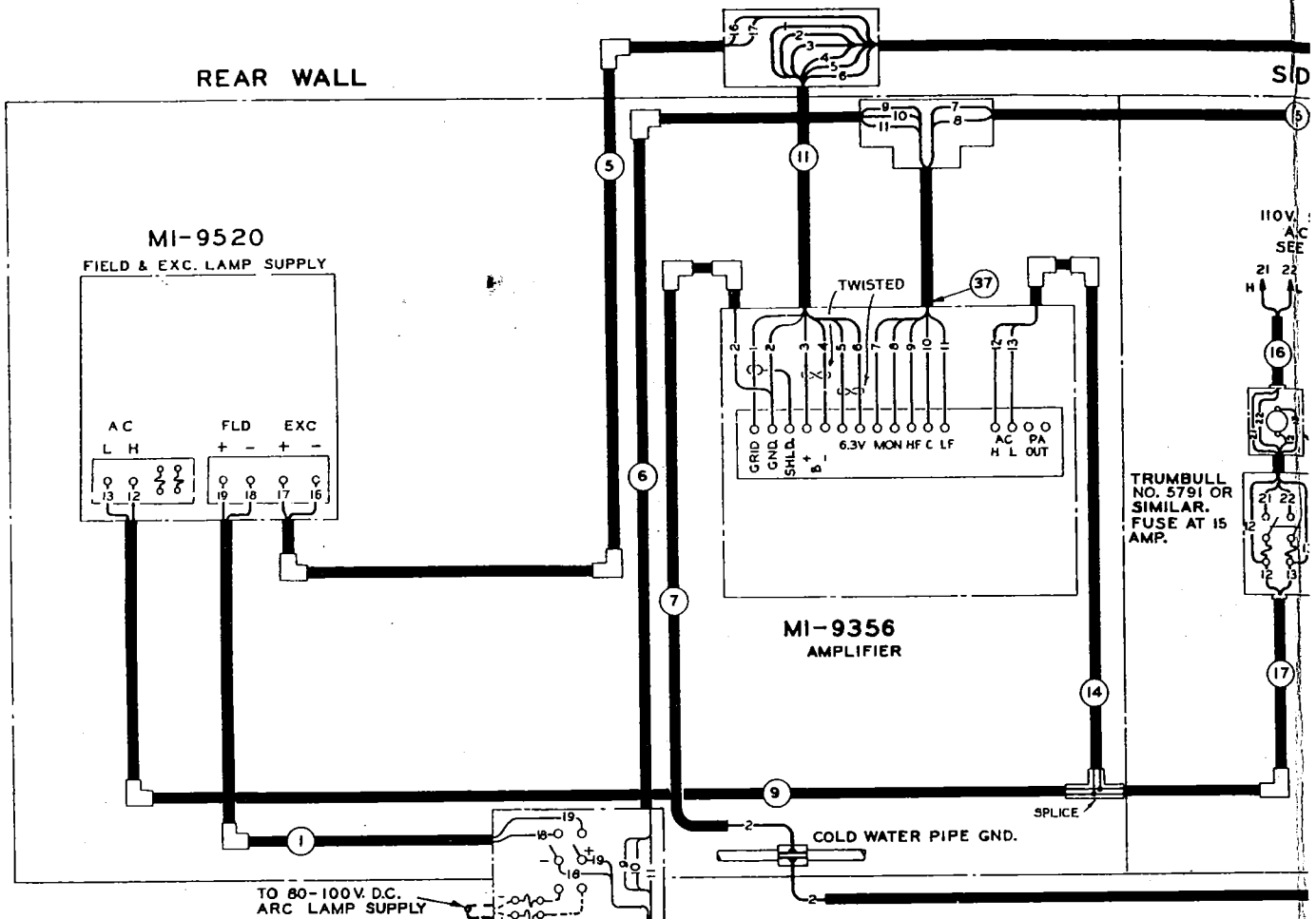

D.P.D.T. SWITCH G.E. NO. 289739, AND FUSE BLOCK G.E. NO. 62965, OR SIMILAR, WITH SUITABLE CONDUIT BOX TO BE SUPPLIED BY THE EXHIBITOR. FUSE 5 AMP.

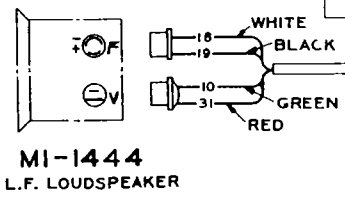
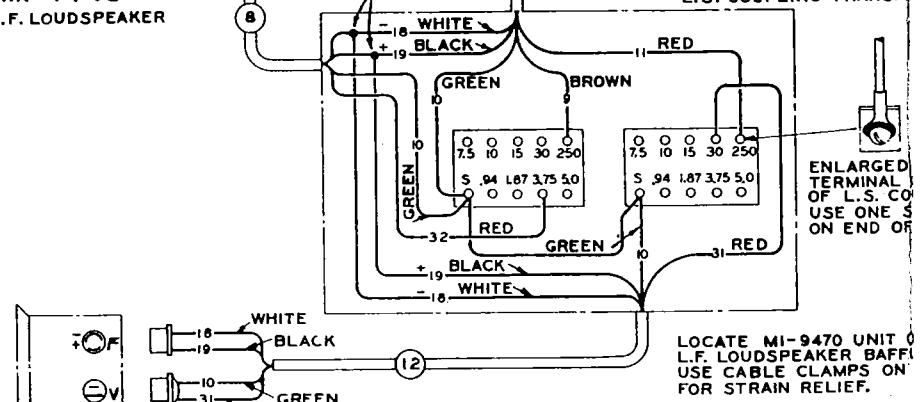
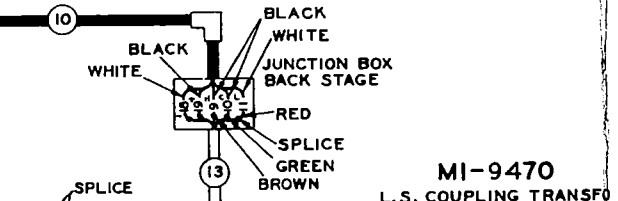
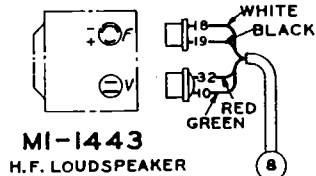

TWO TWO-CONDUCTOR TIREX CAN BE USED IN PLACE OF ONE FOUR-CONDUCTOR CABLE AS SHOWN.

ENLARGED TERMINAL OF L.S. CO USE ONE 5 ON END OF

LOCATE MI-9470 UNIT 0 L.F. LOUDSPEAKER BAFFLE USE CABLE CLAMPS ON FOR STRAIN RELIEF.

SIDE WALL

FRONT WALL

THIS CONDUIT RUN MUST NOT EXCEED 40 FEET IN TOTAL.

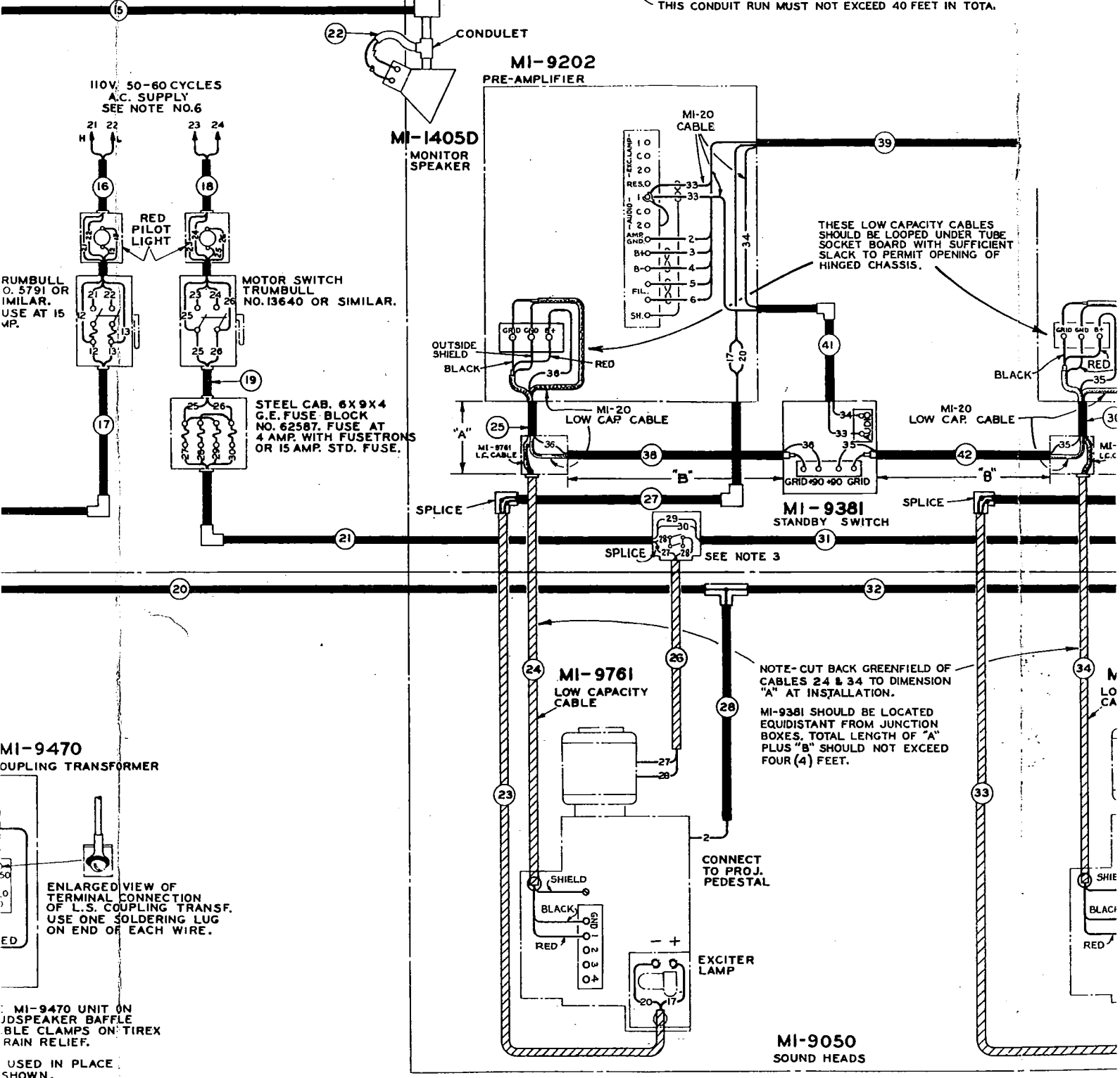

FLOOR PLAN

PROJ. 1

PROJ.

