

Film-Tech

The information contained in this Adobe Acrobat pdf file is provided at your own risk and good judgment.

These manuals are designed to facilitate the exchange of information related to cinema projection and film handling, with no warranties nor obligations from the authors, for qualified field service engineers.

If you are not a qualified technician, please make no adjustments to anything you may read about in these Adobe manual downloads.

www.film-tech.com

Wrap Detector Installation

PRODUCT INFORMATION BULLETIN #3510

The Wrap Detector provides a means of shutting down the platter/projector after a payout control malfunction causes 20-30 wraps of film around the control plate. It is installed at the top of the column and has two single pin connectors that connect to the column wiring harness.

The Wrap Detector can be configured to shut down the platter or projector by means of single pin connectors in the power supply. Unless specified, the factory configures the Wrap Detector to disconnect power to the platter. It can also be configured to wire directly into the projector's fail safe circuit by means of an external cable. This cable has two single pin connectors that connect to the wire harness in the power supply. The configuration of the single pin plugs for either mode of operation is shown in the Power Supply, Column\Arm schematic section of the Platter Operation Manual. (SWITCH SPECS: 15A 125, 250, 480 VAC \ 1/2A 125VDC, 1/4A 250VDC)

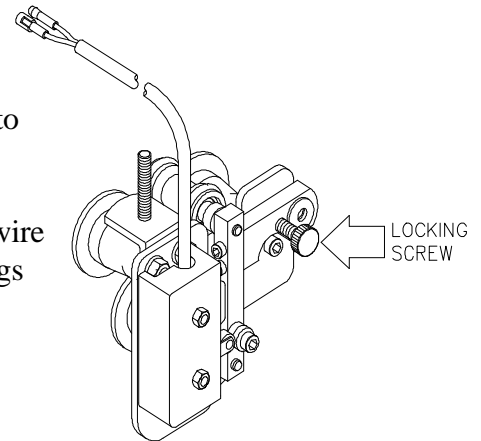
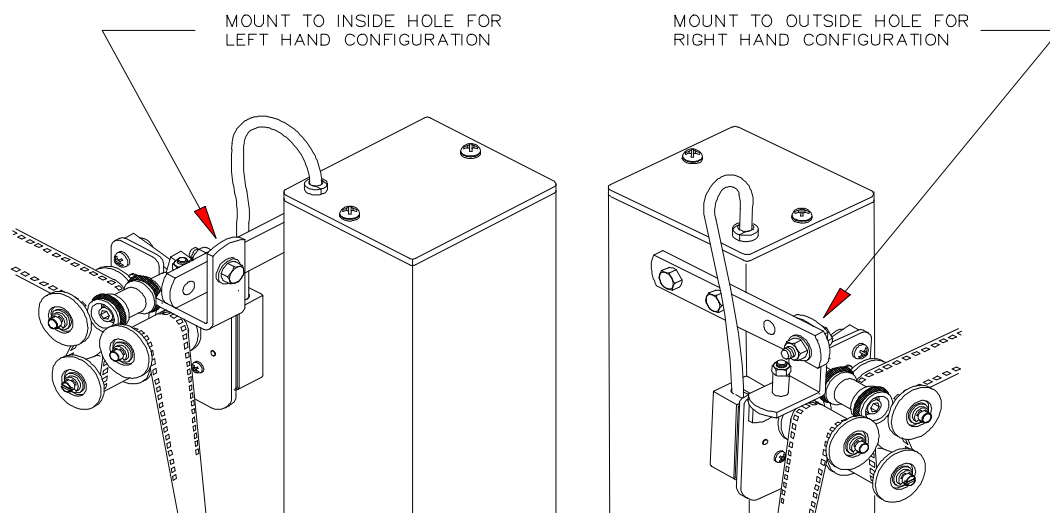

Figure 1

The Wrap Detector has a tensioning roller that provides enough film tension to allow a 12 foot free span of film between the platter and projector without support rollers. This tensioning roller can be removed if desired.

There is a locking screw located on the pivot bar as shown in Figure 1. This locking screw is used to lock the Wrap Detector in its normal operating position after it has tripped. The locking screw should only be tightened long enough to clear the malfunction. Once the malfunction has been cleared the locking screw should be loosened to allow the pivot bar to pivot freely.

The Wrap Detector is shipped as a left hand feed unit. If your platter installation requires right hand feed the Wrap Detector can be changed to a right hand feed unit as outlined on pages 2-3.



LEFT HAND

RIGHT HAND

Film paths for left and right handed Wrap Detectors are shown above

WRAP DETECTOR (LEFT HAND FEED)

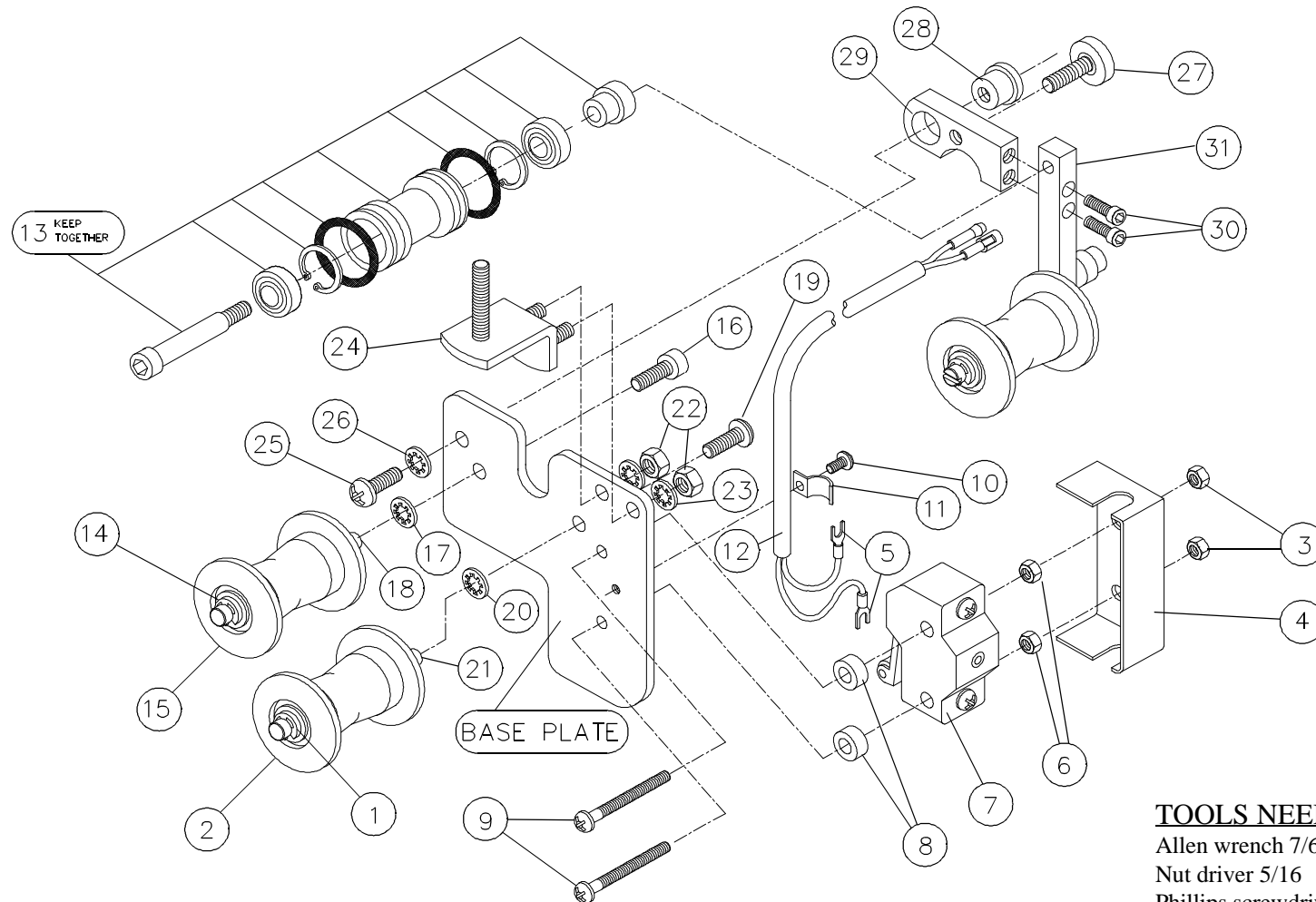

TOOLS NEEDED

Allen wrench 7/64, 1/8, 5/32

Nut driver 5/16

Phillips screwdriver (medium)

Straight blade screwdriver (small)

CONVERSION FROM LEFT HAND FEED TO RIGHT HAND FEED

1) Disassemble the left handed Wrap Detector in order from 1 to 30. Take the parts off and lay them in a straight horizontal line in front of you. See next page.

WRAP DETECTOR (RIGHT HAND FEED)

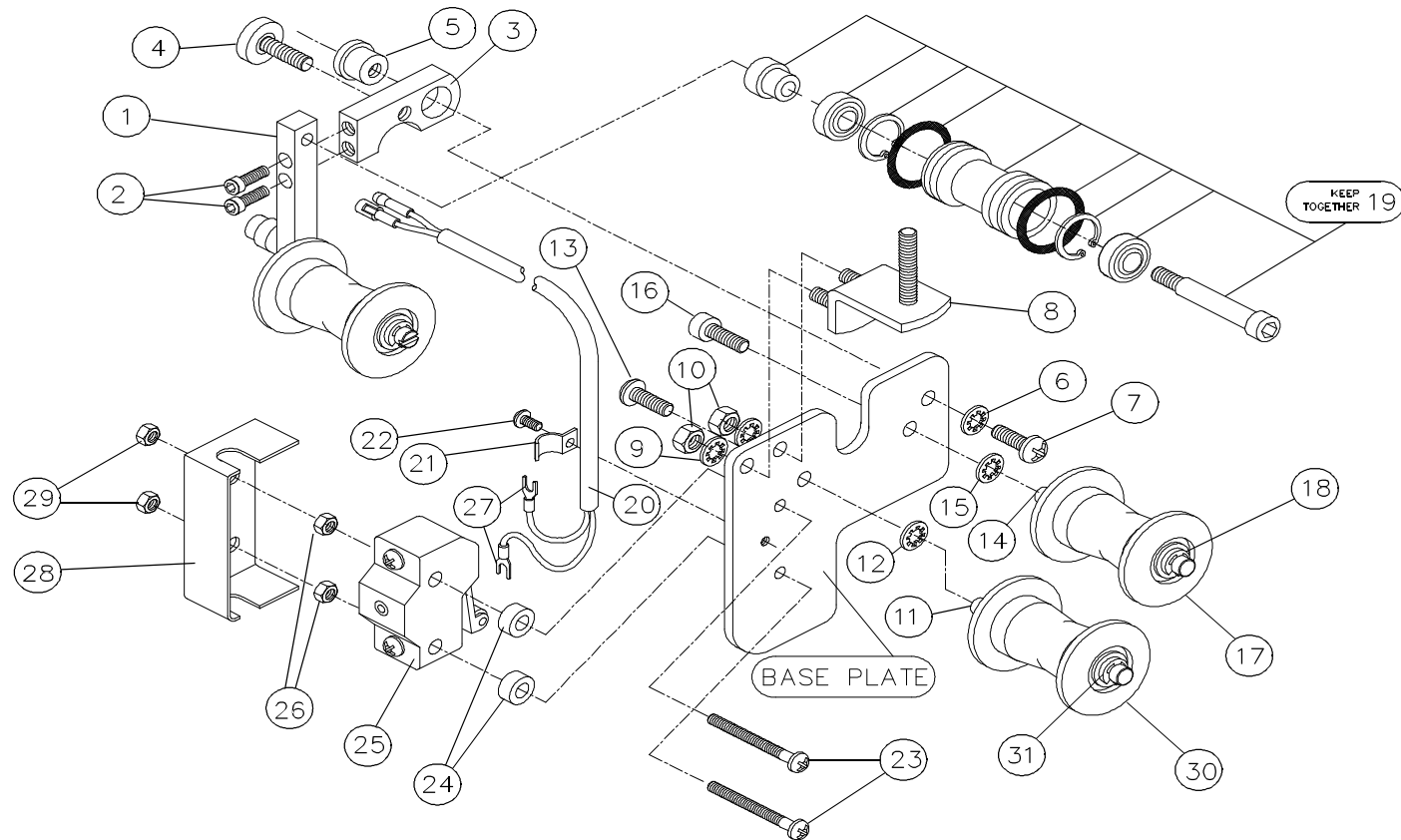

- 2) Assemble the parts in order from 1 to 30. Start with the last part taken off and work backwards through the line of parts.
NOTE: Lay pieces 1 & 3 on a flat surface before tightening the allen bolts (items 2). This will insure proper alignment.

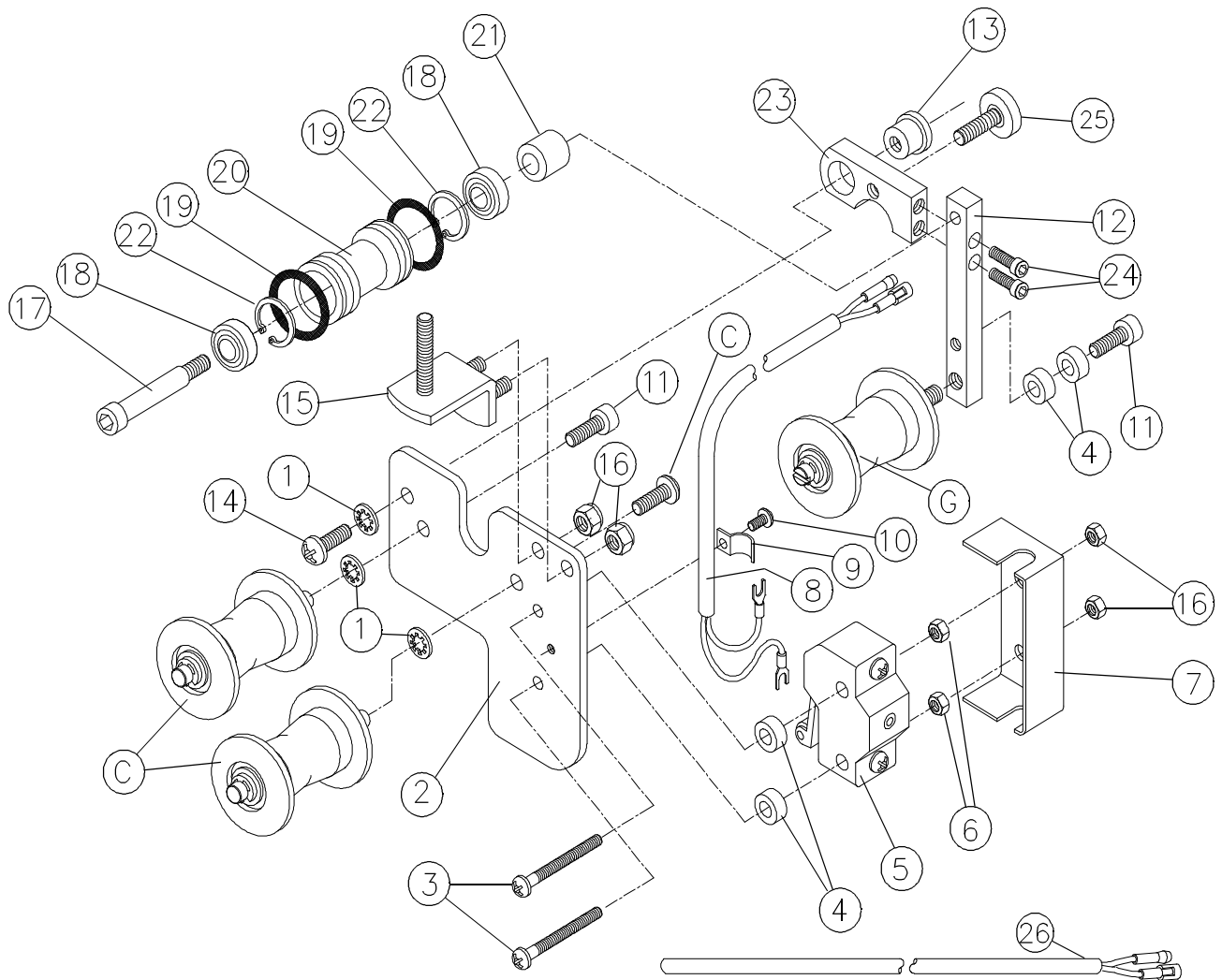

ILLUSTRATED PARTS BREAKDOWN

- | | |
|----------------------------------------------|-----------------------------------------------|
| C) 1447 Pulley Shaft #6 & Pulley Assy. 35mm. | 13) 3385 Wrap Detector Pivot Bushing |
| G) 1504 Column Shaft & Pulley Assy. 35mm. | 14) 1071 Screw PTH 10-32 X 3/8" |
| 1) 1078 Lockwasher #10 - Internal Tooth | 15) 3416 Wrap Detector Swivel Brkt. Assy. |
| 2) 3381 Wrap Detector Base Plate | 16) 1084 Locknut, Nylon Insert 6-32 |
| 3) 3388 Screw PPH 6-32 X 1 1/4" | 17) 3392 Shoulder Screw 1/4" X 1 1/2" |
| 4) 2400 Spacer - 3/8" Slum. Rnd. #10 X 1/8" | 18) 2407 Bearing 5/8" OD X 1/4" ID |
| 5) 2413 Micro Switch - Short Roller Arm - HD | 19) 3390 O-Ring 1/8" X 13/16" ID X 1 1/16" OD |
| 6) 1083 Nut Hex 6-32 | 20) 3386 Wrap Detector Tensioner Roller |
| 7) 3387 Wrap Detector Switch Cover | 21) 3453 Wrap Detector Roller Spacer |
| 8) 3394 Wrap Detector Plug Harness | 22) 3310 Retaining Ring Internal 5/8" Bowed |
| 9) 3393 Cable Clamp | 23) 3383 Wrap Detector Pivot Bar |
| 10) 1065 Screw PTH 6-32 X 1/4" | 24) 3397 SHCS 6-32 X 1/2" |
| 11) 1592 SHCS 10-32 X 1/2" | 25) 3735 Wrap Detector Locking Knob Assy. |
| 12) 3384 Wrap Detector Roller Bar | 26) 3746 External Hook Up Wire Harness 15' |