

Film-Tech

The information contained in this Adobe Acrobat pdf file is provided at your own risk and good judgment.

These manuals are designed to facilitate the exchange of information related to cinema projection and film handling, with no warranties nor obligations from the authors, for qualified field service engineers.

If you are not a qualified technician, please make no adjustments to anything you may read about in these Adobe manual downloads

www.film-tech.com

INSTRUCTION MANUAL

X-90

Xenon Projection Console

Type 31000, 31002

Rev. January 2000



STRONG INTERNATIONAL

a division of Ballantyne of Omaha, Inc.

4350 McKinley Street

Omaha, Nebraska 68112 USA

Tel 402/453-4444 • Fax 402/453-7238

PREFACE

THE STRONG X-90 is a projection console using a horizontally mounted xenon bulb as the light source. The reflector is an 11 inch deep ellipse type designed to operate at 25-3/4 inches from the film plane. The standard reflector is dichroic ("cold") coated to reduce heat at the film plane and prolong bulb life.

THE CONSOLE LAMPHOUSE is designed to incorporate xenon bulbs ranging from 1000 to 2500 watts. The standard switching xenon power supply is adjustable to operate these wattages throughout their current ranges. Bulb Adapter Kit No. 31934 is supplied with each X-90 console, and will accommodate all bulbs approved for used in the X-90.

TWO BULB SEAL BLOWERS are wired to the lamphouse control circuit to maintain the bulb seals at a safe operating temperature. An air vane switch, located at the rear blower outlet, will interrupt lamphouse operation in the event of a main blower failure, or if the main blower is not moving adequate air. The blower motors are protected by a circuit breaker on the xenon power supply.

INTERLOCK SWITCHES on both the rear and operator side lamphouse access doors prevent operation of the lamphouse if either door is opened. These switches insure operator safety and must not be bypassed. The off-operator side door may be opened during operation to permit adjusting the xenon power supply. Key locks on all doors assure access to authorized personnel only.

THE STANDARD ANALOG INSTRUMENT PANEL includes an elapsed time meter to record the number of hours the bulb has operated. These hours should be recorded on the XENON BULB RECORD on the inside back cover of this manual in the event of a warranty adjustment. The ammeter indicates the operating current of the bulb; see the warranty information packed with the bulb to determine the correct current setting for the bulb in use. Pressing the VOLTAGE switch will change the meter to display the DC voltage at the arc. Volts times amperes will indicate exact wattage.

AN OPTIONAL DIGITAL INSTRUMENT PANEL employs a backlit LCD screen which continuously displays the bulb current (amperes), arc voltage, operating wattage, and elapsed hours. The Bulb Hours display (BLB) can be re-set upon installation of a new bulb, while the actual elapsed hours of the X-90 console are accumulated by the Total Hour (HR) display. To establish and maintain an accurate history of xenon bulb usage, the Total Hour (HR) figures should be entered on the Xenon Bulb Record.

A POWER DISTRIBUTION CENTER is standard on the X-90. The input power requirement is a four-wire, three phase AC line, voltage as specified on the equipment Data Plate. An adequate earth ground is also required. See the INSTALLATION INSTRUCTIONS following.

ALL BRANCH CIRCUITS are individually protected by means of circuit breakers wired to the distribution panel. A ten ampere, 115 V.AC feed for the lamphouse exhaust blower is provided, and includes an interlock circuit to disable lamphouse operation if the exhaust blower is not energized. A MASTER contactor energizes all branch circuits simultaneously.

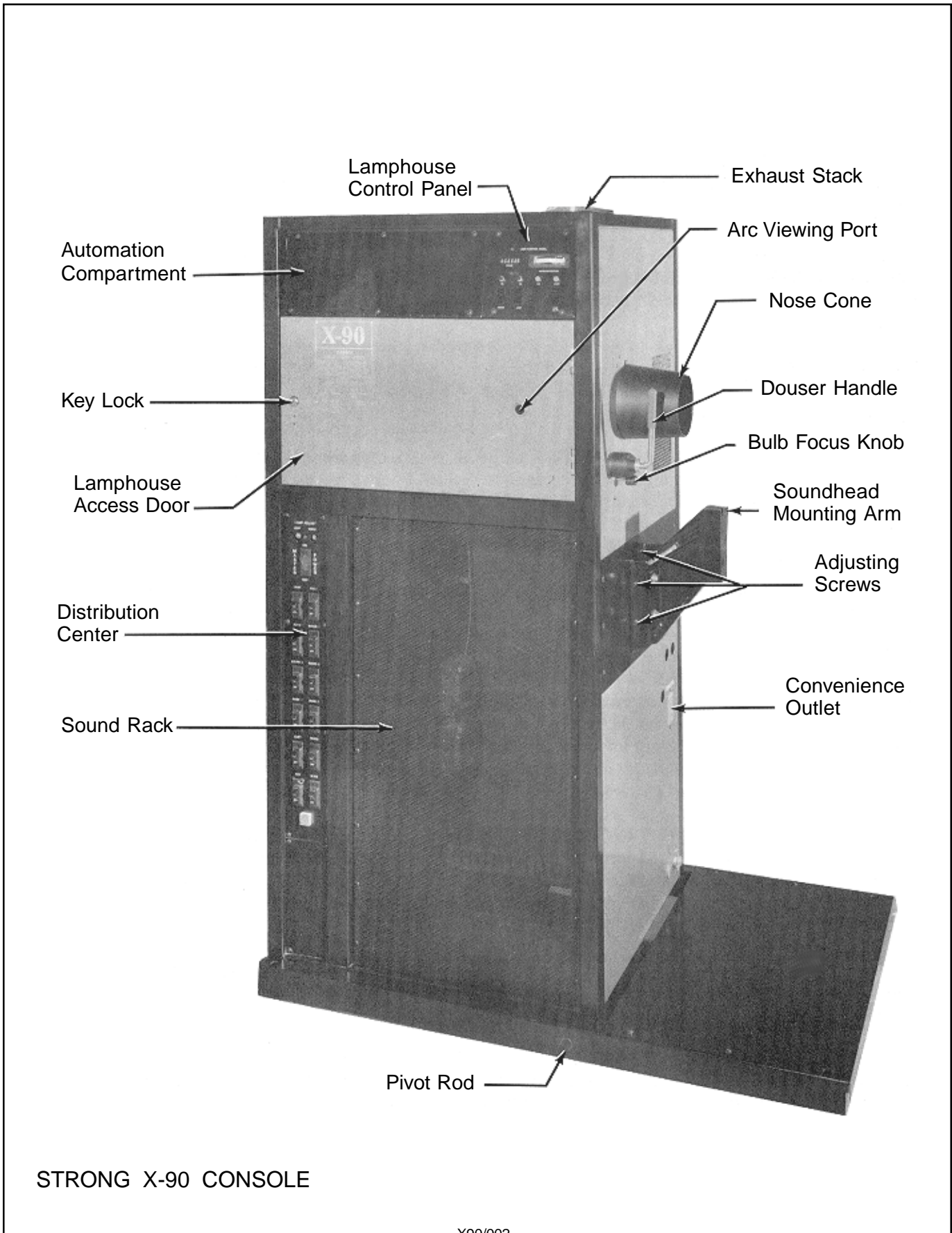

INSTALLATION

INSPECT THE SHIPMENT immediately on arrival and report any damage to the freight carrier. It is the responsibility of the consignee, not the shipper, to file these claims.

MOVE THE CONSOLE as close as possible to its installed position in the booth before removing it from the shipping pallet.

WHEN ORDERED less the pre-wire option, the console can be disassembled to accommodate narrow doorways and passages. The xenon power supply may be disconnected and dismantled to further reduce weight. Current models feature twistlock connectors on both AC input and lamphouse outputs.

TO DISASSEMBLE THE CONSOLE, remove the (2) hex head screws from the tilt adjust locks at the rear of the console. Both screws are accessible through the rear door. Remove (1) snap ring from the end of the pivot rod at the front upright portion of the console, and slide the pivot rod out. The upright portion of the console can then be lifted from the base.

IF REMOVING the xenon power supply from an earlier model X-90, note carefully the wire numbers and/or colors to enable correct re-connection. The output side of the power supply contains the DC leads, positive (red) and negative (black), (5) numbered control leads, and a ground lead (green). The input side includes (3) AC leads (L1, L2, L3), and a ground lead (green). Observe correct polarity and control wire numbering when replacing these leads.

REASSEMBLE THE CONSOLE by reversing the above sequence. The angle of tilt will be set at a subsequent point of the installation.

ASSEMBLE THE FOUR LEVELING FEET to the base of the console before or when removing the console from the shipping pallet. Position the console in front of the projection port as required.

THE AC SUPPLY to the X-90 must be a four-wire three phase line, plus ground, installed in conformance to local codes by a qualified electrician. Voltage requirement is stamped on the equipment Data Plate. These AC connections are made to the bottom terminals (as marked) of terminal board TB1, located behind the rear access door and below the master contactor enclosure. Wire connections are as follow:

AC Phase	TB1-1,2,3
Ground	TB1-4
AC Neutral	TB1-5

WHEN ORDERED with Strong automation, all automation terminals are factory prewired. See the installation manual for the correct automation system for the interconnections to house functions.

CONSOLES SHIPPED without automation controllers can be wired for automatic or remote lamphouse ignition by connecting a sustained 5 ampere dry contact between terminals 3 & 6 in the xenon power supply. These terminals are located behind the access panel above the data plate on the power supply cabinet. DO NOT apply voltage to these terminals.

IF A STRONG or other manufacturer's automation is installed subsequent to the installation of the X-90 console, the wires and/or cables must be routed through proper wire paths such as inside the upright console frame channels or the stainless steel wire channel (Figure 1, Item 68) provided. Self-adhesive mounts for standard plastic tie wraps are supplied inside the wire channels of the X-90. Terminal 13 of TB1 provides a five ampere 115 V.AC feed to power an automation controller. To comply with the listing requirements of Underwriters Laboratories, the AC input to any automation controller must be hard-wired to a barrier strip or solder posts supplied by the manufacturer of the automation. Do not use plug-in connectors for the AC input.

ADDITIONAL PROTECTED AC FEEDS for booth and house functions (Masking, Curtain, etc.) are available on the upper terminals of TB1 (Figure 1, Item 48). Connecting the ceiling exhaust blower motor to TB1-11 will enable switching the exhaust blower directly from the console.

X-90 DISTRIBUTION CENTER
 Assembly No. 25266

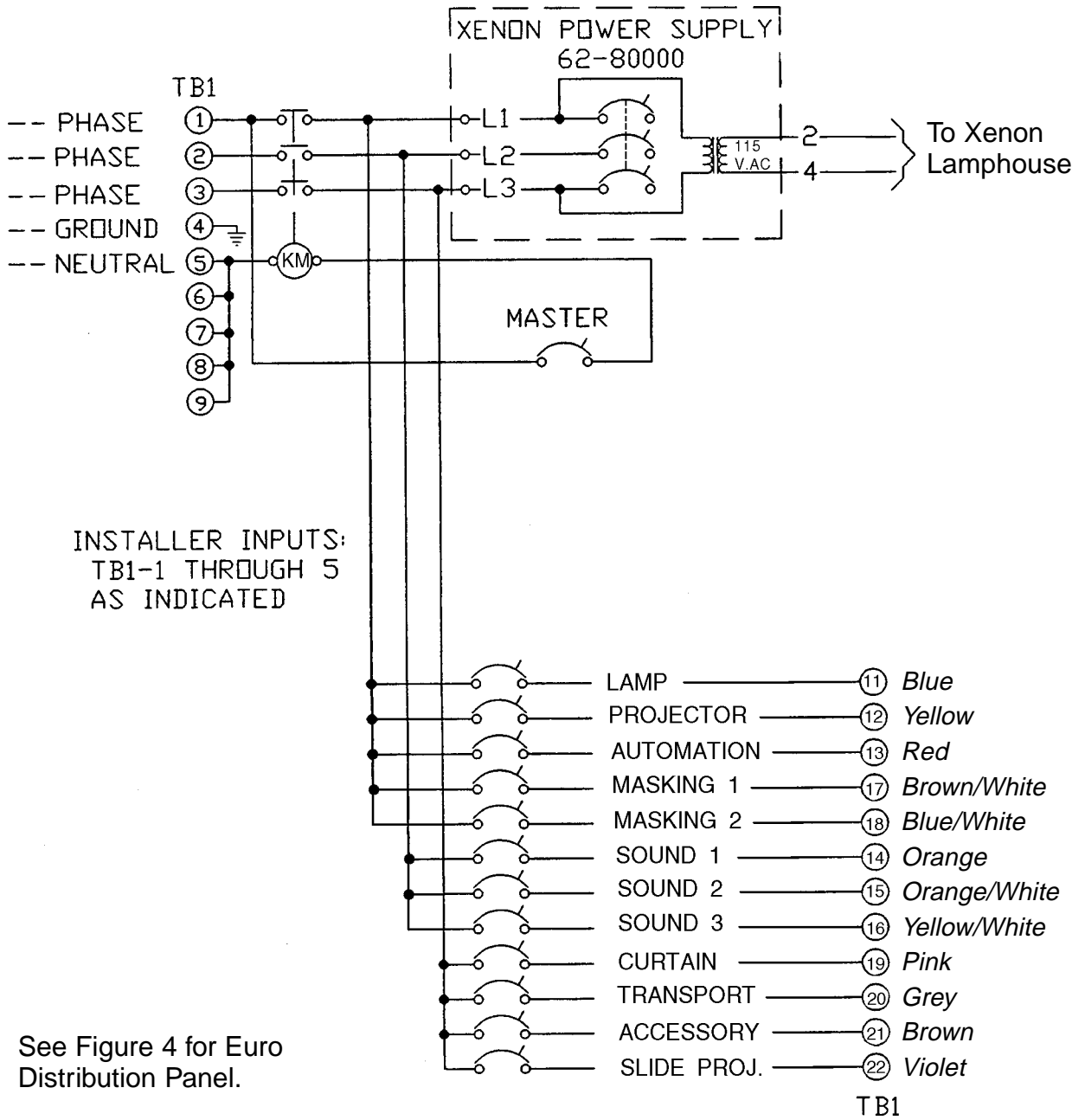

EXHAUST SYSTEM INSTALLATION

THE EXHAUST STACK of the X-90 console lamphouse is designed to fit a six inch (15.25cm) diameter duct. This size ducting (rigid or flexible) must be used throughout the entire system and installed to eliminate any possibility of downdraft or rain dripping into the lamphouse. The exhaust blower must be capable of removing 300 cubic feet of air per minute (cfm) from the lamphouse.

A CIRCUIT (TB1-6 & 11) is wired to the X-90 distribution panel to allow interconnecting a 115 V.AC ceiling exhaust blower. This circuit is protected by the 10 ampere circuit breaker marked LAMP. An advantage to wiring the external exhaust blower to the X-90 is that it can be energized simultaneously with the other booth circuits through the MASTER contactor.

EXHAUST AIR FLOW is to be measured at the exhaust stack and not determined by the rating of the blower. Static pressure caused by bends and long duct runs reduces actual air flow at the end of the run. If more than one console is installed in a common projection booth, the exhaust air flow must be measured at *each* individual console.

EXCESSIVE EXHAUST DRAFT, such as 600 cfm or more, should be avoided. Excessive air flow alters the overall cooling pattern of the xenon bulb. Should it be necessary to limit the air flow through the exhaust system, install bypasses rather than dampers. See the illustration below.

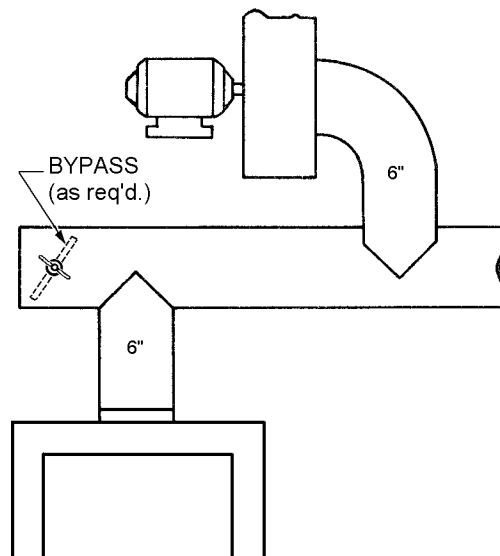

IF THE CONSOLE is replacing a carbon arc lamphouse, make certain that the exhaust system is thoroughly cleaned of all carbon ash or residue. Carbon ash, falling on a xenon bulb, will rapidly burn into the quartz bulb envelope and possibly shorten bulb life.

PROJECTOR MOUNTING & ALIGNMENT

THE SOUNDHEAD MOUNTING ARM is drilled for the standard four-hole configuration common to all currently manufactured soundheads and combined soundhead/projector units. The arm casting is designed to locate the projector aperture at the correct 25-3/4 inch working distance from the lamphouse reflector. The Ballantyne Model VII soundhead requires a .75 inch spacer block (Part No. 31556) between the soundhead casting and the mounting arm to correctly position the aperture. This block is supplied with the X-90 console when ordered for use with a Ballantyne projection system.

LEVEL THE CONSOLE BASE to the floor of the projection booth. Level the machined top surface of the soundhead before securing the mounting bolts. Mount the projector to the soundhead according to the manufacturer's instructions.

CLEAR THE SHUTTER BLADES and changeover/fire shutter douser(s) as required and install the alignment kit as illustrated. Insert the aligning cord through the CinemaScope aperture plate, and use an object of sufficient weight to keep the cord taut. Close the film gate to retain the test aperture plate.

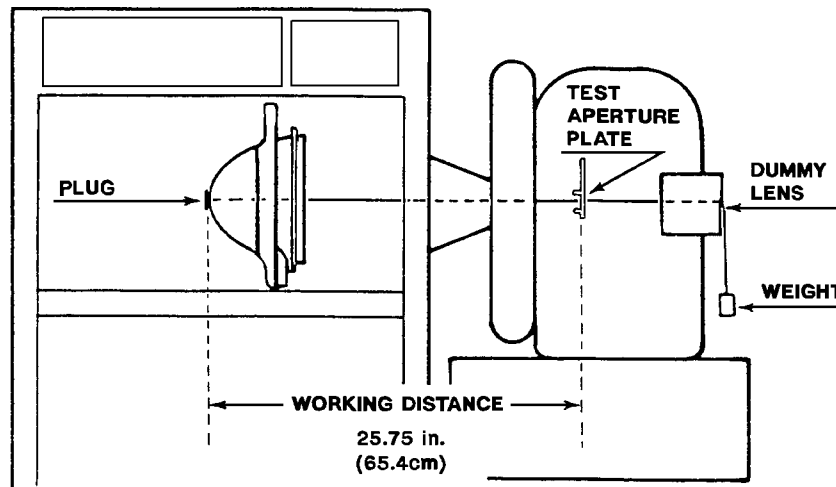

LOOK THROUGH THE LAMPHOUSE ACCESS DOOR and locate the reflected image of the aligning cord on the reflector. If the reflected image of the cord is not superimposed on the cord, that is, if it appears above or below the cord, the projector is not aligned to the lamphouse reflector.

THE REFLECTOR is factory prealigned to the approximate optical center of the picture aperture in the projector. Fine adjustment, to center the aligning cord in the test aperture, is done by loosening the (4) hex head bolts securing the projector mounting arm and alternately tightening and loosening the (6) allen head positioning screws. Retighten the (4) hex head mounting bolts after positioning the projector.

BECAUSE OF MANUFACTURING TOLERANCES, it may be necessary to reposition the reflector after having centered the aligning cord in the test aperture. To do so, loosen the #8 screws (Figure 2, Item 54) from the back of the reflector flange and alternately tighten and loosen the spring-loaded allen head reflector mounting screws (Figure 2, Item 8) to achieve the desired "single string" image on the reflector. Retighten the #8 screws, and secure the locknuts, after completing the alignment. DO NOT overtighten to the point where the lockscrews can warp the reflector flange.

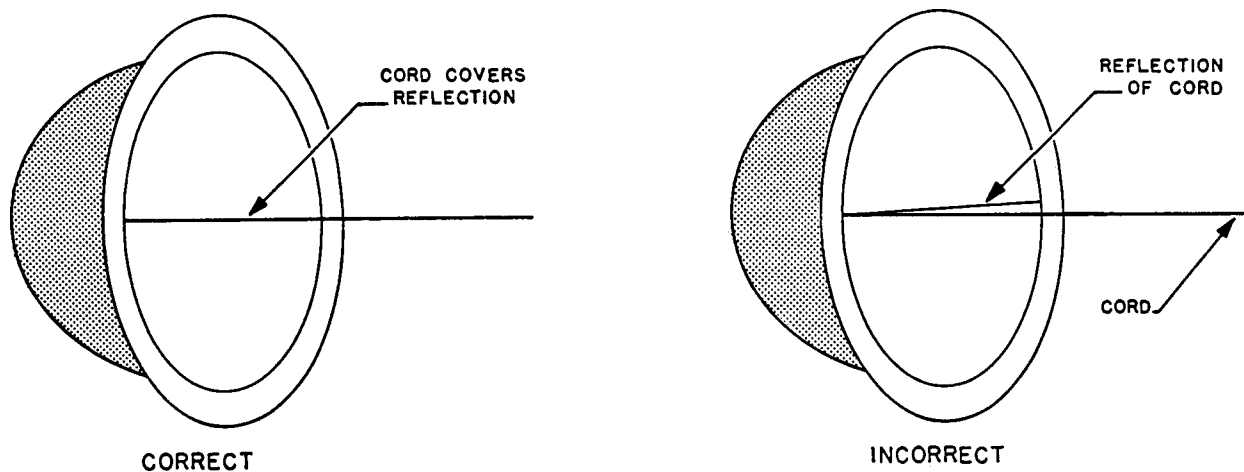

ILLUSTRATIONS showing the correct and incorrect aligning cord images appear above. The "CORRECT" illustration shows the cord covering its reflected image. The "INCORRECT" drawing, showing the cord and its reflected image, denotes a small degree of misalignment. Observe the results of the above adjustments by carefully watching the shifting position of the cord's reflection.

UPON COMPLETION of the alignment procedure, remove the cord and its associated fixtures, and restore operation of the changeover/fire shutter douser. Store the alignment kit parts in a secure location in the booth; replacement of a reflector will require a second alignment. Rotate the focus control knob to center the anode support column in its travel path prior to installing the xenon bulb.

SAFETY PROCEDURES

THE XENON BULB is highly pressurized. When ignited, the normal operating temperature of the bulb increases the pressure to a level at which the bulb may explode if not handled in strict accordance to the manufacturer's operating instructions. The bulb is stable at room temperature, but may still explode if dropped or otherwise mishandled.

REFER BULB REPLACEMENT and service to *qualified personnel* with adequate protective clothing (face shield, clean cotton gloves, welder's jacket). For routine lamphouse service, observe the following procedures:

1. Allow the bulb to cool to room temperature before opening the lamphouse. Put on protective clothing described above.
2. De-energize the xenon power supply at the AC source before opening the lamphouse compartment.
3. When possible, encase the bulb in its protective cover when cleaning or servicing the lamphouse interior. The bulb, when outside the lamphouse, must be encased in the cover.
4. Clean the bulb after it has cooled to room temperature. Do not touch the quartz envelope of the bulb; fingerprints will burn in and create hot spots which may shorten bulb life. If fingerprints are made, they should be carefully removed with methyl alcohol and cotton prior to bulb operation.
5. Never view an ignited xenon bulb directly. **BLINDNESS OR PERMANENT EYE DAMAGE MAY BE INCURRED.**
6. Use only xenon bulbs designated as OZONE FREE. When possible, vent the lamphouse exhaust to outside atmosphere.
7. Maintain the lamphouse blower(s) in good operating condition. Keep the blower inlet(s) clean for unrestricted air flow.
8. To insure maximum bulb life, operate the lamphouse blower and the exhaust system for **at least** ten minutes after extinguishing the bulb.
9. If returning a bulb for warranty adjustment, pack it in its original shipping container. Complete and return all required warranty information.
10. Dispose of expired bulbs that are beyond warranty in the following manner: Wrap the bulb tightly in several layers of canvas or heavy cloth. Place it on a hard surface and shatter the envelope with a sharp hammer blow. **DO NOT** place an unshattered bulb in an ordinary refuse container.
11. **DO NOT PERMIT UNAUTHORIZED PERSONNEL TO PERFORM OR ATTEMPT ANY PHASE OF XENON BULB HANDLING OR SERVICE.**

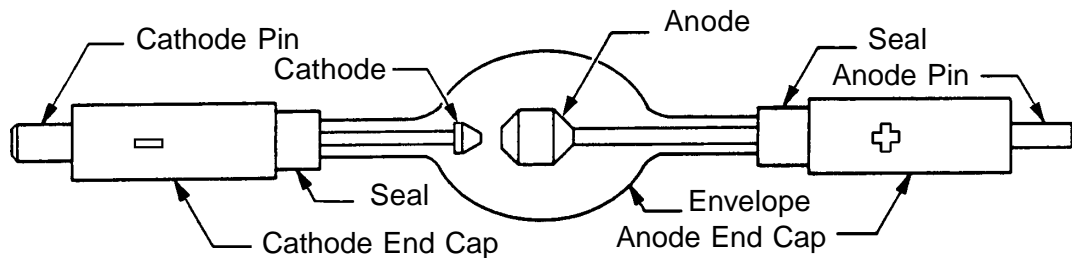

X-90 BULB ADAPTERS

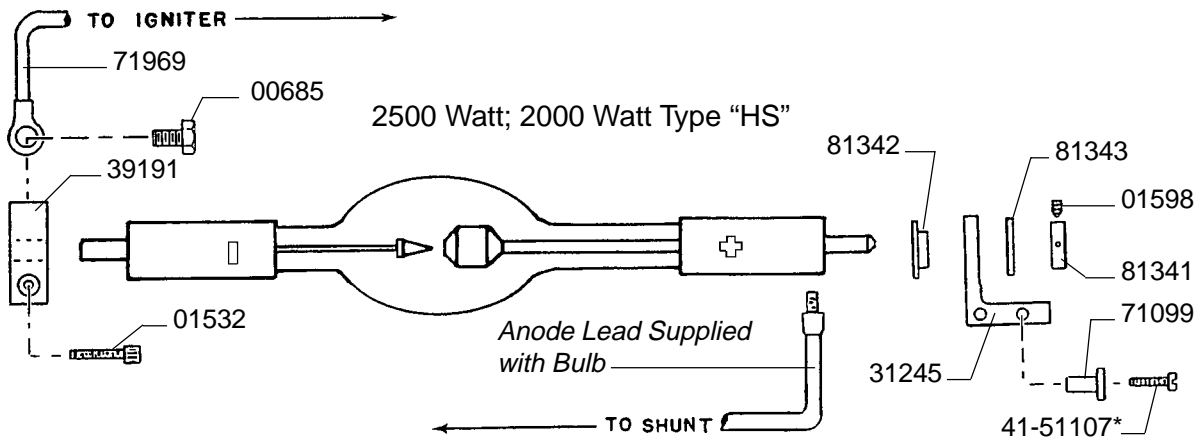
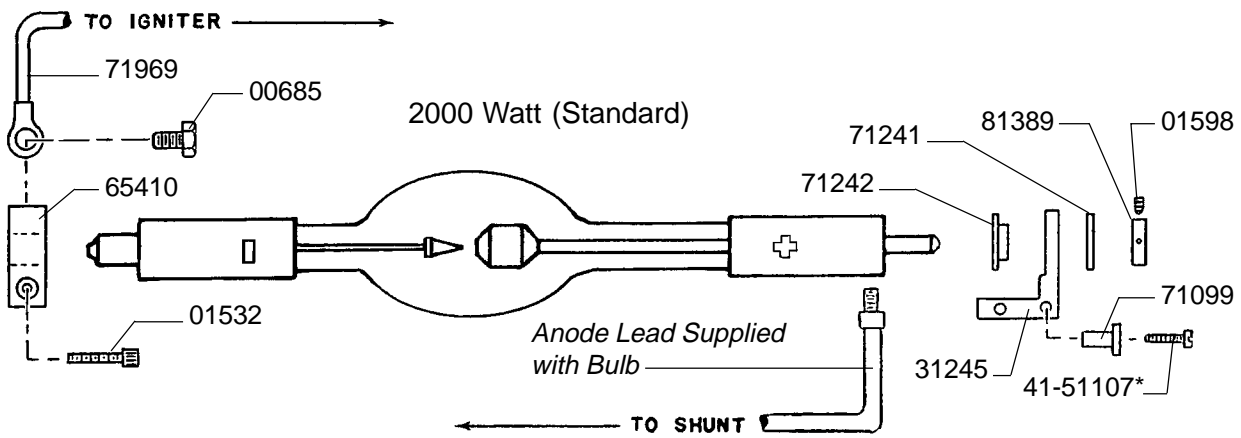
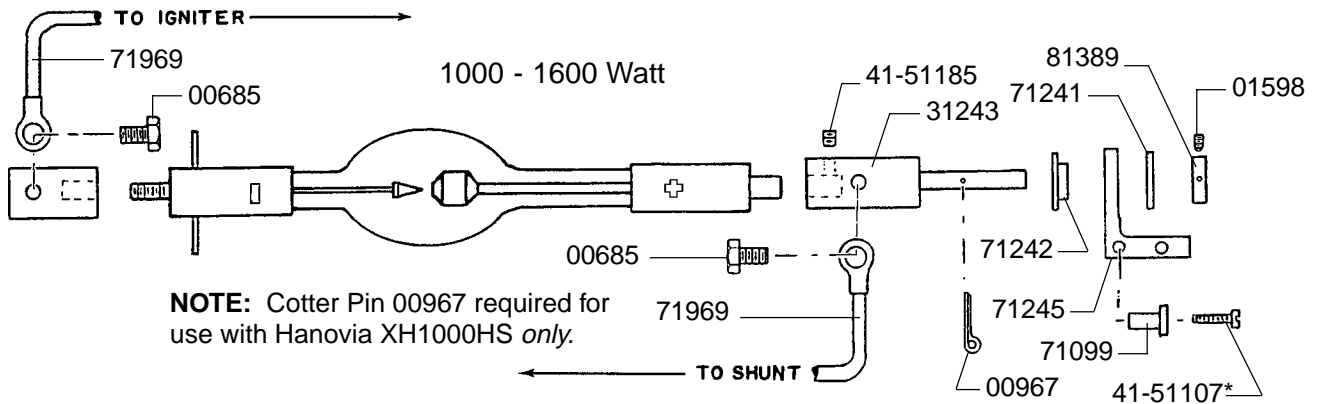

* Do Not Deform 31245 Support Casting by overtightening 41-51107 Screw. Tighten Screw *snug only*

XENON BULB INSTALLATION

THE X-90 CONSOLE is designed for operation with the following xenon bulbs ONLY. Bulbs not listed below must be certified by their manufacturer as being 100% interchangeable with the listed bulbs, and designated as ozone free. Refer to the SAFETY PROCEDURES before handling the xenon bulb.

<u>WATTAGE</u>	<u>HANOVIA</u>	<u>OSRAM</u>
1000	XH1000HS	XBO1000W/HS OFR
1600	XH1600HS	XBO1600W/HS OFR
2000	XH2000HW	XBO2000W/H OFR
2000	XH2000HS	XBO2000W/HS OFR
2500	XH2500HS	XBO2500/HS OFR

BULB ADAPTER KIT 31934 is included with each X-90 console, and includes all adapters and hardware required to mount any of the above bulbs. Parts shown for use with the 2500 watt bulb are also used on 2000 watt "HS" bulbs now offered by numerous suppliers. It is recommended to store the unused components of the kit in a secure location in the projection booth. They will then be available in the event of a decision to change to a higher or lower lamp wattage.

THE SPLIT CATHODE V block behind the reflector is factory set to accommodate the 1.25" (35mm) diameter of a standard 2000 watt bulb end cap. Sliding the segments closer together will raise the center of the V to allow for the smaller diameter of a 1000 or 1600 watt bulb end cap and cathode adapter 31244. Each segment mounts to the base using a single socket head screw; moving the segments equal distances will maintain the optical center. The shorter overall length of the 2500 watt and 2000 watt "HS" bulb requires the addition of a spacer block (81336) and use of a one-piece cathode support 71675. These components are factory-installed when the X-90 is ordered for use with a 2500 watt bulb.

ASSEMBLE ALL BULB ADAPTERS as illustrated on the X-90 XENON BULB ADAPTERS page to the bulb prior to insertion into the lamphouse. DO NOT apply torque pressure to the quartz vessel of the bulb in this operation; handle the bulb by the metal end caps only. If possible, leave the bulb in its protective enclosure when installing adapters. Do not touch the quartz vessel material with bare fingers.

NOTE CAREFULLY the position of the 31245 Anode Support Casting. It will assemble to the bulb in (1) of (2) positions, with the horizontal portion either directed toward the bulb, or away from the bulb, depending on the desired bulb wattage. This adapter must be correctly positioned to enable bulb focus. Note also the correct hole location for the 71099 Bushing and mounting screw. The bushing must be in the correct hole for proper bulb focus. Do not overtighten the mounting screw.

TWO 71969 LEAD ASSEMBLIES are supplied with the bulb kit. One lead assembly is needed to connect the cathode contact clamp or adapter to the igniter post; the second lead is required as an anode lead for 1000 and 1600 watt bulbs. The lead assemblies have two different size terminals; attach the smaller terminal to the bulb clamp or adapter.

BULB INSTALLATION (continued)

DISMOUNT THE UPPER COVER of the stainless steel bulb enclosure by removing the (2) thumbscrews. Center the front bulb support pedestal by rotating the bulb focus knob adjacent to the douser handle. Insert the bulb, with adapters mounted, into the lamphouse. Pass the cathode (-) end of the bulb through the center hole in the rear of the reflector. *Take care not to dent or scratch the surface of the reflector.* Rest the cathode end cap of the bulb in the V block behind the reflector, and mount the anode support casting to the anode pedestal using the 71099 Bushing and 41-51107 Screw. Again, insert the bushing through the correct hole. Do not overtighten the mounting screw; excessive torque may deform the 31245 casting.

RUN THE CATHODE LEAD through the insulated bushing at the back of the bulb enclosure and connect it to the left (output) terminal post of the igniter. Connect the anode (+) lead to the rear terminal of the shunt. Dress the anode lead close to the upright pedestal to minimize the shadow. Make certain all DC connections are tight, and replace the stainless steel bulb enclosure cover.

REFER TO THE DOCUMENTATION packaged with the xenon bulb. It contains important information prepared by the manufacturer of the bulb, including the recommended nominal current level at which the bulb will begin operation. The current output adjustment for the X-90 power supply is located above the ammeter. Do not exceed the maximum current level specified by the bulb manufacturer; the X-90 power supply is capable of overdriving the xenon bulb.

STORE THE BULB PACKAGING and the warranty documentation in a secure location in the projection booth. Record the installation date and lamphouse hours on the Bulb Record card on the back of the console, or on the Xenon Bulb Record on the back cover of this manual.

TYPICAL CURRENT LEVELS

<u>Wattage</u>	<u>Nominal Current</u>	<u>Do Not Exceed</u>
1000	50 A.	58 A.
1600	65 A.	70 A.
2000	75 A.	90 A.
2500	90 A.	100 A.

BULB ALIGNMENT AND OPERATION

CLOSE AND LOCK the lamphouse access doors. Turn on the exhaust system. Close the douser. Energize the distribution panel by turning the MASTER circuit breaker to the ON position (light ON). When the LAMP circuit breaker is closed, the indicator lights for "POWER," "AIR," and "DOOR" will light.

IN NORMAL MODE, the LAMP "ON" indicator and the xenon bulb will not light until cued by the automation controller. For test purposes, select "MAN." mode (upper position). The LAMP "ON" indicator will light, and the xenon bulb will ignite.

CHECK THE BULB CURRENT at the ammeter. If not operating within specified range, adjust the xenon power supply to obtain the correct output. The operating current range is noted in the xenon bulb warranty information. Do not exceed the maximum current specified by the bulb manufacturer.

A NEW XENON BULB is normally operated at or near its nominal current. As the bulb ages, the quartz envelope normally will darken. The current can then be gradually increased to compensate for the light loss caused by the darkening envelope.

PRESS THE "LAMP VOLTS" switch to change the ammeter to display arc voltage. To determine exact wattage, multiply volts time amperes.

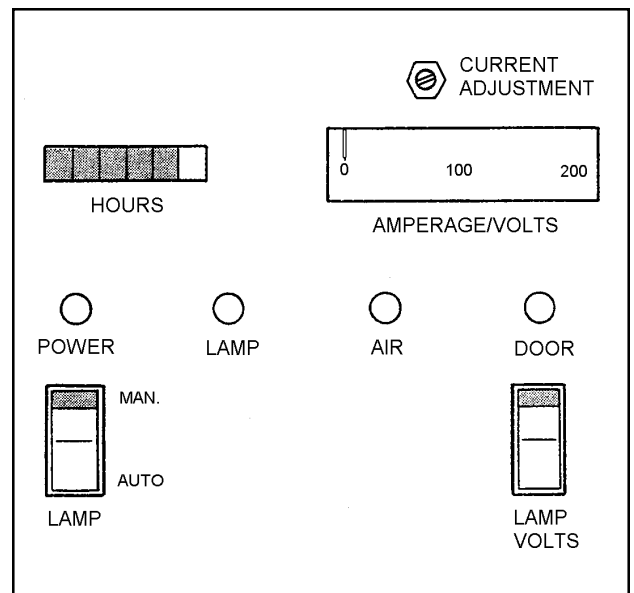

THE ANALOG ELAPSED TIME METER (as illustrated) will record the hours of bulb operation. The meter runs only when the xenon bulb is operating.

THE OPTIONAL DIGITAL INSTRUMENT PANEL continuously displays the bulb current (A), arc voltage (V), wattage (W), and elapsed hours. Elapsed hours are displayed as Bulb Hours (BLB) and Total Hours (HR). Bulb hours can be re-set to zero after replacing the xenon bulb. Prior to bulb ignition, electrical data is displayed as zeros, but the backlighting of the display screen indicates that power is ON.

ADJUSTMENT CONTROLS are provided to correctly position and focus the xenon bulb. Bulb adjustment controls, located on the distribution panel immediately above the MASTER circuit breaker, position the bulb inside the reflector on the horizontal and vertical planes. The focus control knob, located adjacent to the douser handle, moves the bulb in and out of the reflector on the horizontal plane.

REMOVE THE PROJECTION LENS, turn on the projector motor, and open the douser. A black spot should appear in the center of the screen. Adjust, tilt, or reposition the console as required to center the spot on the screen.

A SCISSORS JACK is mounted to the rear of the console base to permit setting the projection angle. To adjust, open the rear access door and loosen the (2) lock nuts on the inside of the upright frame. Tilt the console to the desired projection angle by operating the jack with a 3/4 inch socket or box end wrench. When set to the correct angle, retighten the lock nuts.

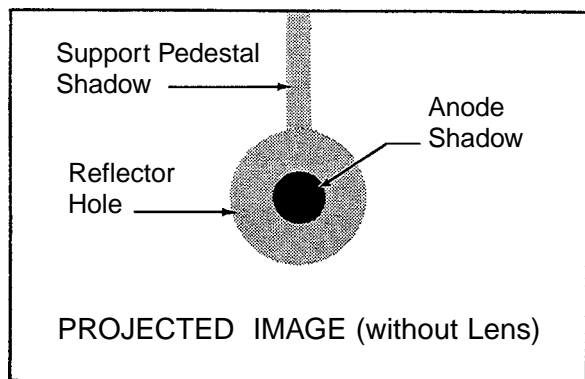

AN IMAGE similar to that illustrated on the left should appear on the screen. Adjust the focus control knob to sharpen and define the spot inside the shaded projection of the reflector center hole. Using a flat bladed screwdriver, rotate the VERT and HORIZ adjustments until the black spot is centered in the shadow as illustrated.

IF THE SHADOW of the bulb anode cable is pronounced, shut off the lamp, allow the bulb to cool, and open the access door. Dress the anode cable closer to the bulb support pedestal.

THE SPLIT CATHODE V block behind the reflector is factory set to accommodate the 1.25" (35mm) diameter of a standard 2000 watt bulb end cap. Operate the focus control knob adjacent to the douser handle and observe the anode shadow as it moves inside the reflector center hole. The dark spot should remain centered inside the shaded area. If the anode shadow raises or lowers as the bulb tracks forward or back, the split cathode V block must be adjusted.

SLIDING THE V BLOCK SEGMENTS closer together or farther apart will raise or lower the center of the V. Each segment mounts to the base using a single socket head screw; moving the segments equal distances will maintain the optical center. The one-piece cathode support 71675 used with 2500 watt and 2000 watt "HS" bulbs requires no such adjustment.

WHEN THE ANODE SHADOW is centered in the reflector center hole, insert the CinemaScope aperture plate into the projector and install the projection lens. Adjust the focus control knob until the light field on the screen is uniform. Close the lamphouse douser *frequently* during this operation to allow the lens to cool. Prolonged lamphouse operation without film will damage the projection lens. After a uniform field is achieved, file aperture plates to fit the screen and masking.

ALLOW THE BLOWER AND EXHAUST SYSTEM to operate for (10) minutes after extinguishing the bulb. This measure will prolong bulb life, and is required by the bulb manufacturer.

DAILY OPERATION

1. Turn all circuit breakers ON; close the lamphouse douser. Turn on the exhaust system (if not wired through the console distribution panel). Place the LAMP switch in the ON position to ignite the xenon bulb. Open the lamphouse douser only after the projector is running. DO NOT operate the xenon bulb for over twenty (20) minutes with the lamphouse douser closed.

2. If using a booth automation system, leave the lamphouse douser OPEN. The automation controller will switch the xenon bulb ON after starting the projector motor. At the shut-down cue, or in the event of a film break or other automation failsafe fault, the xenon bulb will extinguish. All blowers will continue to operate and cool the bulb and power supply. The automation controller will re-ignite the bulb upon the next show start cue, or after restoration of the fault. The LAMP switch overrides automation control.

CAUTION: If operating the lamphouse in the manual mode (by use of the LAMP switch), as an override to a faulty lamphouse ignition circuit in an automation controller, DO NOT leave the console unattended. In the event of a film break, platter head wrap, or other automation fault, the bulb will *not* extinguish, resulting in possible print and/or projector damage.

3. At the end of the day, allow the console and exhaust blowers to continue operating for at least ten minutes after extinguishing the xenon bulb. This measure assures proper bulb cool-down, and is required by most bulb manufacturers to comply with warranty requirements.

BULB ROTATION

MOST XENON BULB MANUFACTURERS recommend and/or require rotation of horizontal bulbs at 50% warranty life. Refer to the warranty information packaged with the xenon bulb for specific user requirements.

TO ROTATE THE BULB, loosen the socket head screw in the cathode clamp and remove the anode lead terminal from the shunt. Rotate the bulb 180 degrees, re-attach the anode lead terminal, and securely tighten the cathode clamping screw.

ADJUST THE XENON POWER SUPPLY to increase bulb operating current to or just below the maximum level specified for the bulb. Project a white light to the screen to check for an even field and correct the bulb positioning as required. Operate the xenon bulb at this higher current level for one or two performances, and then return the power setting to its previous level. Temporary operation of the bulb at high current following bulb rotation will restore the cathode tip and enhance ignition at the new arc position.

BULB WARRANTY RETURNS

RETURN BULBS upon which a warranty claim is being made to the theatre equipment dealer through whom the bulb was purchased. Pack the bulb in its original shipping carton with the protective cover over the bulb. Complete and enclose all warranty forms supplied by the bulb manufacturer.

WARRANTY CREDIT will not be allowed if the bulb failure is related to mishandling, improper installation, faulty supporting equipment, or abuse.

REFLECTORS damaged by a xenon bulb explosion should be forwarded to the *bulb* supplier for warranty adjustment. Include an invoice copy authenticating the cost of the replacement reflector.

DIGITAL DISPLAY

UPON ENERGIZING the LAMP circuit, the backlighting will illuminate the LCD screen. When all blowers are operating and all access doors are closed and correctly secured, the display will appear as shown:

000V 000A 0000W
1234BLB 12345HR *

FOR PURPOSES OF ILLUSTRATION, the above display indicates a non-operating bulb with 1,234 hours of use installed into a console with 12,345 hours of operation. The asterisk (*) at the end of the second line, when flashing, indicates that the display is active and awaiting input. Upon bulb ignition, the upper line will display the arc voltage (V), the DC current (A), and the operating wattage (W) of the bulb; the asterisk symbol will be replaced by a plus (+) sign. The figures will shift for the first few moments of xenon bulb operation, but will stabilize after the bulb reaches operating temperature and pressure.

IN THE EVENT of an open interlock switch, the lower line will display an appropriate diagnostic measure, i.e. CHECK REAR DOOR or CHECK BLOWER. Diagnostic messages are defined as follows:

CHECK REAR DOOR: Make certain the rear console access door is closed and locked.
CHECK FRONT DOOR: Make certain the operator's lamphouse access door and locked.
CHECK BLOWER: Make certain the squirrelcage blower below the igniter is energized and operating, and that the ducting to the bulb compartment is secure.

THE OPTIONAL 31902 EXHAUST AIR VANE SWITCH, if used, is wired in series with the air flow switch mounted to the base plate below the reflector. Check both switches in the event of a CHECK BLOWER error message.

WHEN THE INTERLOCK CIRCUIT is complete, closure of the LAMP switch, or the automation closure (3 & 6), will energize the contactor of the xenon power supply. The high open circuit ("no load") DC voltage will be displayed. When the open circuit voltage reaches 140 V.DC, the igniter will generate a RF pulse to bridge the gap between the bulb electrodes. This pulse, coupled with the high open circuit DC voltage, will ignite the bulb. The voltage reading will then fall to the bulb's sustaining level, and the DC amperes (A) and wattage (W) will be displayed continuously until the bulb is extinguished.

FAILURE of the xenon power supply to generate the high open circuit voltage will not cause an error message to appear, but will be apparent by the *zero* voltage and current reading displayed on the LCD screen. Make certain the (2) circuit breakers on the power supply cabinet are ON and not tripped, and check the line fuse. These components are accessible through the off-operator side door of the X-90.

THE STRONG SWITCHING POWER SUPPLY also includes Phase Loss Detection and Brown-Out Protection which will disable the power supply in the event of problems in the AC supply line. See the power supply Instruction Manual for detailed information.

ELAPSED HOURS will begin counting upon bulb ignition. Bulb hours (BLB) are limited to four digits, and are re-set when the xenon bulb is replaced. To re-set bulb hours, press the RESET button accessible through marked hole below the LCD screen. The 5/64" allen wrench used to tighten the front bulb collar set screw is the correct diameter to clear the hole. NOTE: when recording start-up and removal hours on the Xenon Bulb Record, use the total elapsed hours (HR) figures. The (BLB) figure, re-set upon installation of the bulb, is a convenience feature ONLY. Basing records of the lamp system on the total hours (HR) figures permits an accurate and ongoing history of bulb usage.

IF THE XENON BULB fails to ignite after several igniter pulses, additional diagnostic messages will display on the LCD screen:

CHECK PWR SUPPLY: If no DC current is sensed, and voltage does not exceed 125 V.DC, check the xenon power supply. Repair or replace as required.

CHECK IGNITER: If the DC open circuit voltage reaches and exceeds 140 V.DC and the igniter fails to pulse, replace the igniter.

DIAGNOSTIC MESSAGES serve as prompts and suggestions but do not replace traditional troubleshooting procedures. If an access door is closed and secured but transmits an error message, check the subject door interlock switch with an ohmmeter and replace if defective. Dirt or dust fouling an air vane switch will cause a "blower" error message. A "power supply" or "igniter" error message might be caused by a loose or oxidized connection.

MAINTENANCE

VERY LITTLE MAINTENANCE, aside from routine cleaning, is required for the X-90. The cleaning intervals must be determined by the dirt and dust conditions at each installation.

ALLOW THE BULB to cool to room temperature before opening the lamphouse compartment. Observe all safety procedures when working around the xenon bulb.

CLEAN THE REFLECTOR with a clean, dust-free soft cloth. If excessively soiled, the reflector may be cleaned with a commercial liquid glass cleaner. DO NOT use abrasive cleaners of any kind.

LUBRICATE THE SQUIRRELCAGE BLOWER MOTOR periodically using an all-purpose, non-detergent oil. Clean the air inlet screen and inspect the impeller vanes for dust build-up. The front bulb seal blower is permanently lubricated and requires no oiling, but the blower grille should be cleaned.

VACUUM the air intake and exhaust grilles on the xenon power supply cabinet. The intake grille is easily accessible through the back door of the console. It may be necessary to loosen the 1/4-20 fasteners securing the power supply retaining strap, and slide the power supply slightly toward the back, to thoroughly clean the outlet grille. Power supply blowers are permanently lubricated and require no oiling.

DO NOT allow dust build-up to collect on the surface of the xenon bulb. Foreign material will rapidly burn into the quartz envelope and can shorten bulb life. Clean the bulb envelope periodically using a clean cloth and alcohol. Rinse with distilled water.

CHECK ALL ELECTRICAL CONNECTIONS for tightness. Inspect DC termination points for discoloration; re-attach loose connections. Clean or replace oxidized terminals.

X-90 LAMPHOUSE SCHEMATIC (Analog Controls)

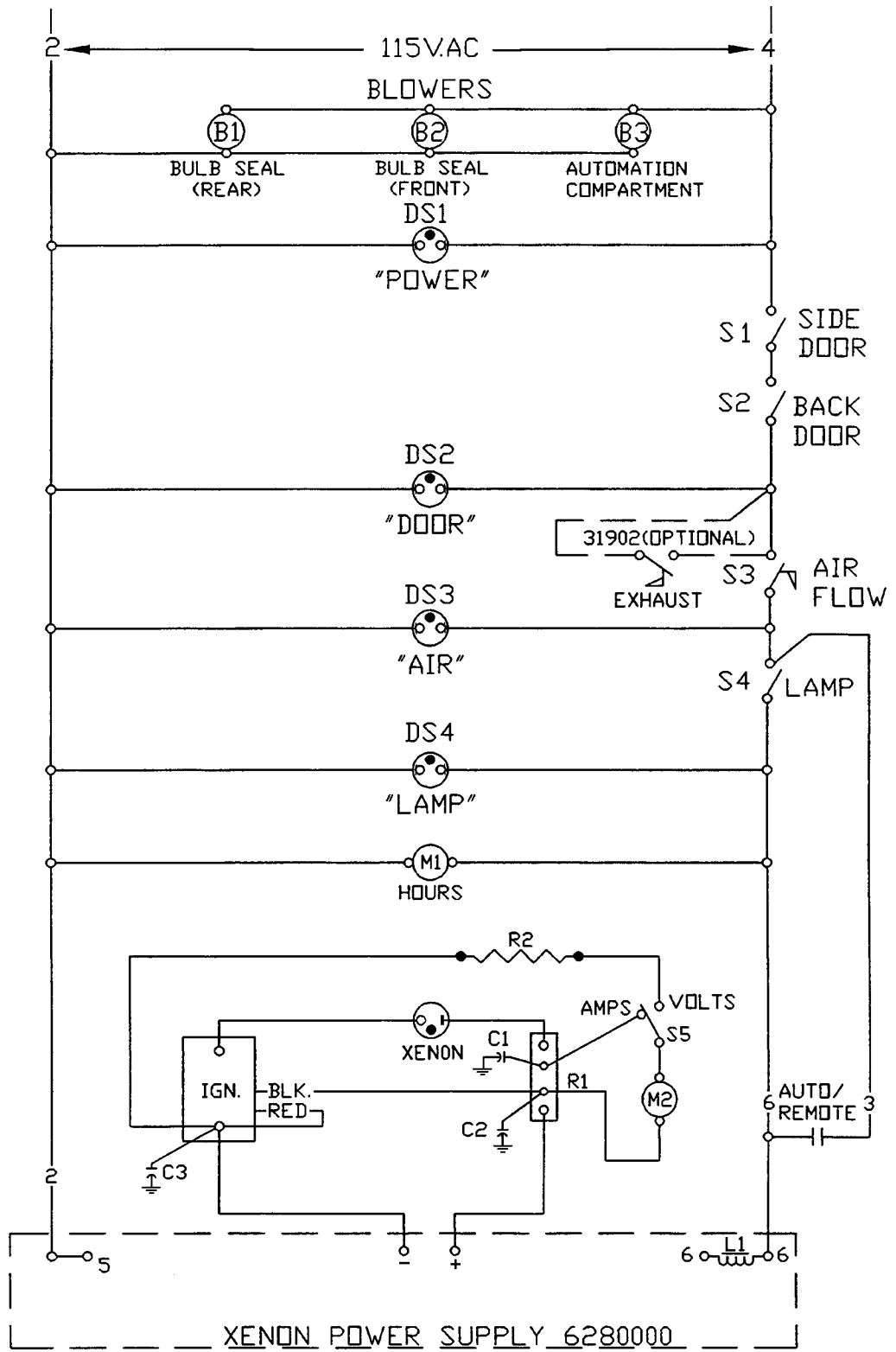

PARTS LIST
Wiring Diagram

Ref.

<u>Desig.</u>	<u>Part No.</u>	<u>Description</u>
B1	31206	Squirrelcage Blower, 115 V.AC, 50/60 Hz.
B2	61-98002	Muffin Fan, 115 V.AC, 50/60 Hz.
B3	61-98002	Muffin Fan, 115 V.AC, 50/60 Hz.
C1	31909	RF Suppression Capacitor, .01 µf, 1000 V.DC
C2	76323	RF Suppression Capacitor, 2 x 1.0 µf, 600 WVDC
C3	76323	RF Suppression Capacitor, 2 x 1.0 µf, 600 WVDC
DS1	81-30002	POWER ON Indicator Light
DS2	81-30002	DOOR Indicator Light
DS3	81-30002	AIR Indicator Light
DS4	81-30002	LAMP ON Indicator Light
-	7056-0007	Lens Cap, Green
IGN	39862	DC Pulse Igniter Assembly
L1 *	25112	Choke Assembly (located in Power Supply cabinet)
M1	2479-1216	Elapsed Time Meter, 60 Hz. (81-32001)
-	2479-1214	Elapsed Time Meter, 50 Hz. (81-32004)
M2	40191	Ammeter, 0-200 A.
R1	82167	Shunt, 150 A. 50 mV.
R2	21-46059	Resistor, 150k Ohm, ½ Watt
S1	24406	Magnetic Interlock Switch Assembly
S2	24406	Magnetic Interlock Switch Assembly
-	21-61007	Magnetic Actuator (for 24406)
S1,2	39260	Pushbutton Interlock Switch (Euro models)
S3	85109	Air Flow Switch
-	12-30538	Mounting Bracket, Air Flow Switch
-	39188	Air Paddle, Actuator Arm
S4	23869	Rocker Switch, LAMP
S5	23868	Rocker Switch, Momentary

S4, S5, and DS1-4 included with 24236 Printed Circuit Board Assembly.

* Required on older 62-80000 Power Supplies in Consoles with Analog Control Panels & 24406 Interlock Switches. Not Required on newer 62-80100 Power Supplies, or on older units with Digital Controls and/or 39260 (pushbutton) Interlock Switches.

See Figure 3 for optional Digital Control Panel Assembly (24088) Parts List.

ANALOG CONTROL PANEL PRINTED CIRCUIT BOARD

Assembly No. 23239

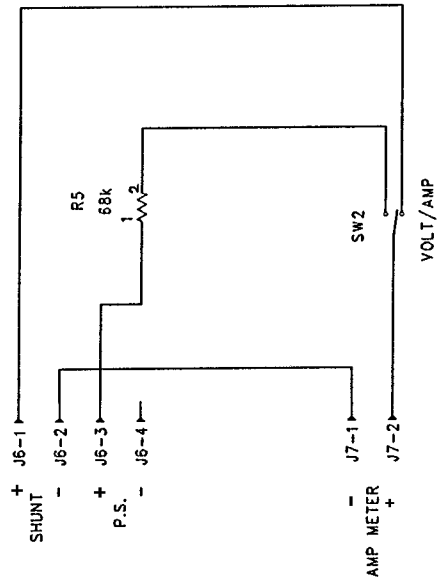
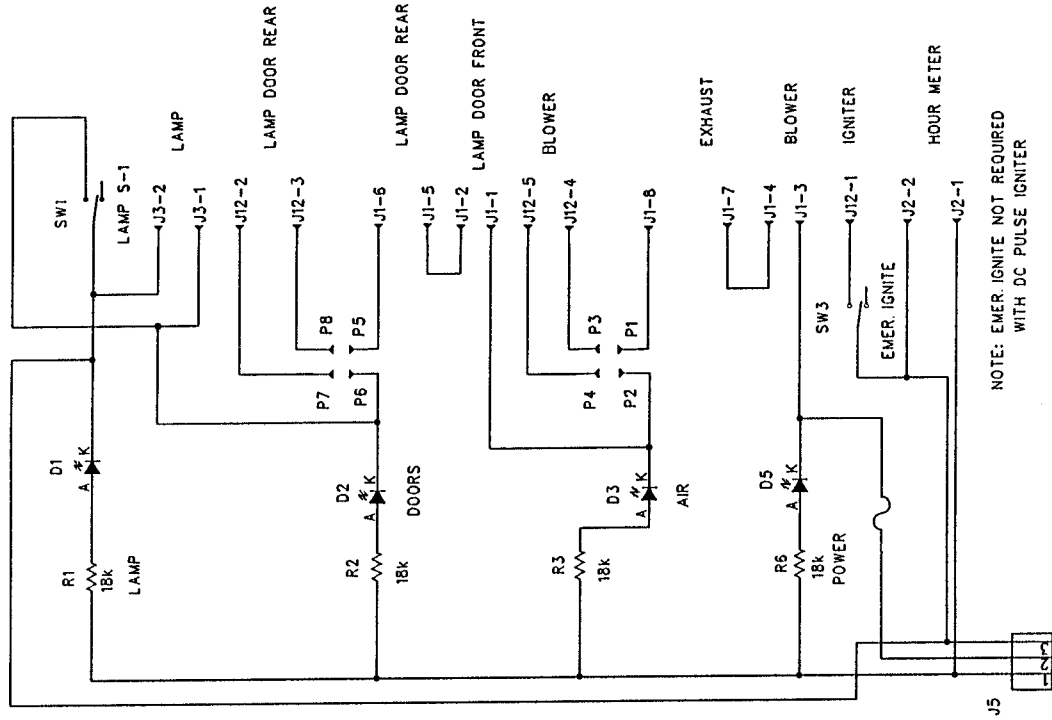

NOTE: EMER. IGNITE NOT REQUIRED
WITH DC PULSE IGNITER

DIGITAL CONTROL PANEL PRINTED CIRCUIT BOARD

Assembly No. 23976 (Wiring Diagram 1 of 3)

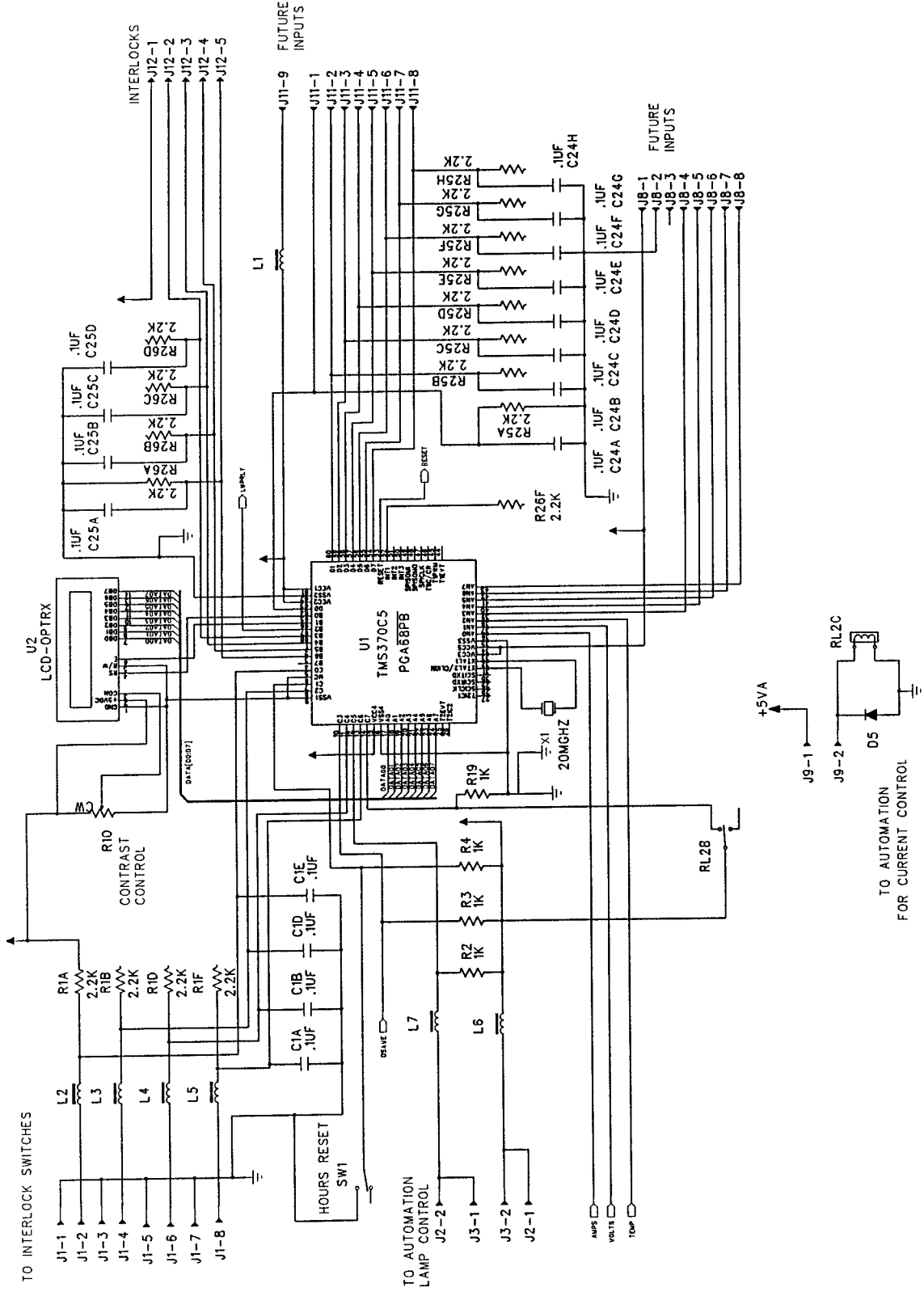

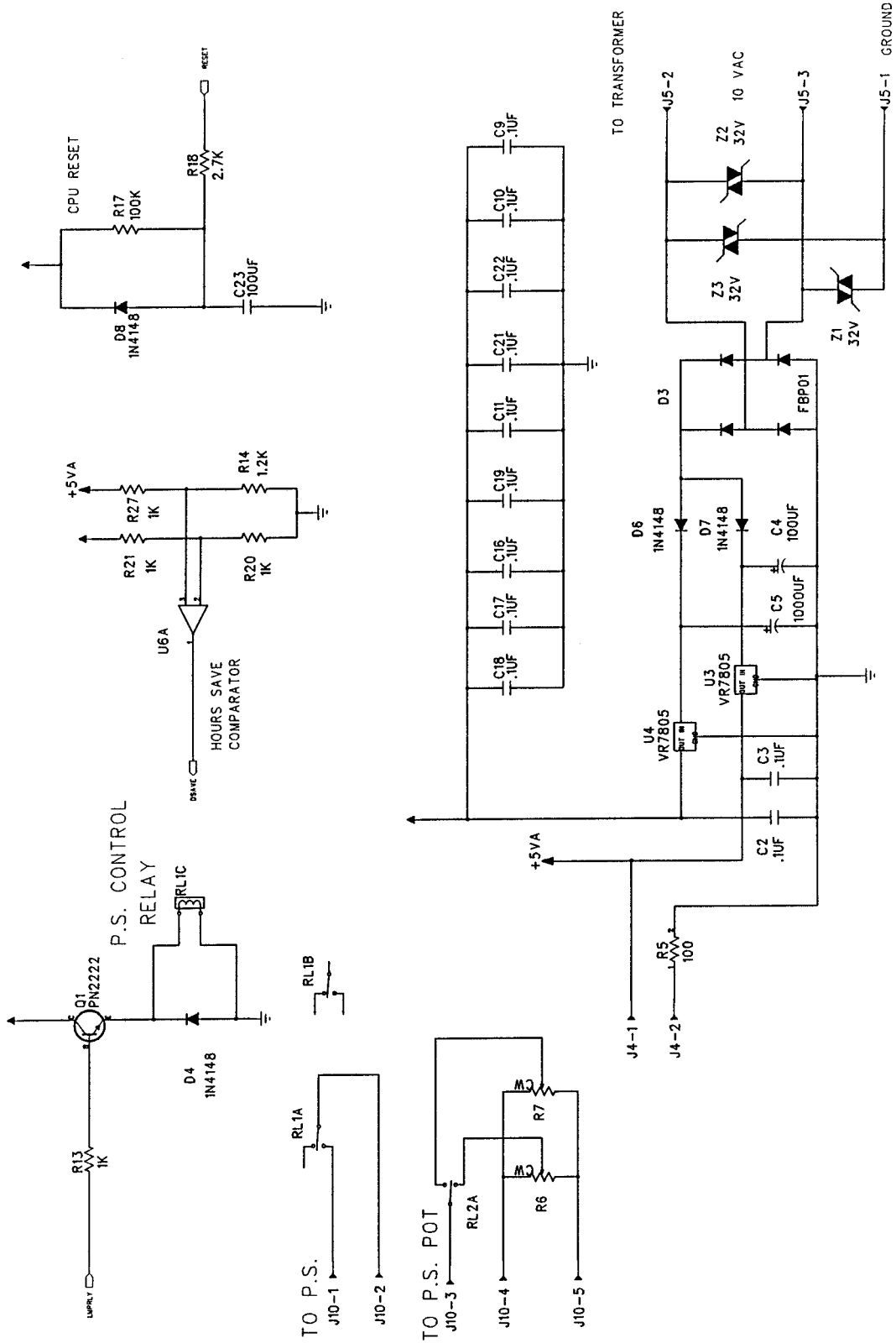

DIGITAL CONTROL PANEL PRINTED CIRCUIT BOARD
 Assembly No. 23976 (Wiring Diagram 2 of 3)

DIGITAL CONTROL PANEL PRINTED CIRCUIT BOARD

Assembly No. 23976 (Wiring Diagram 3 of 3)

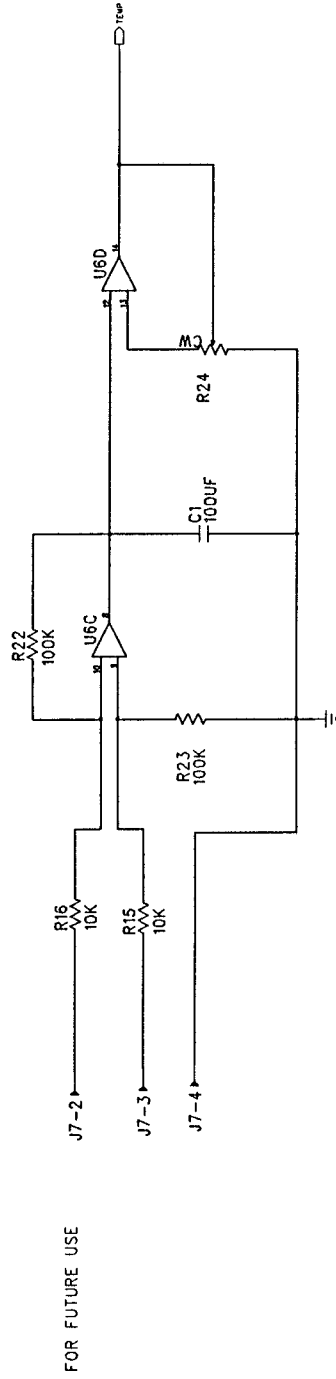
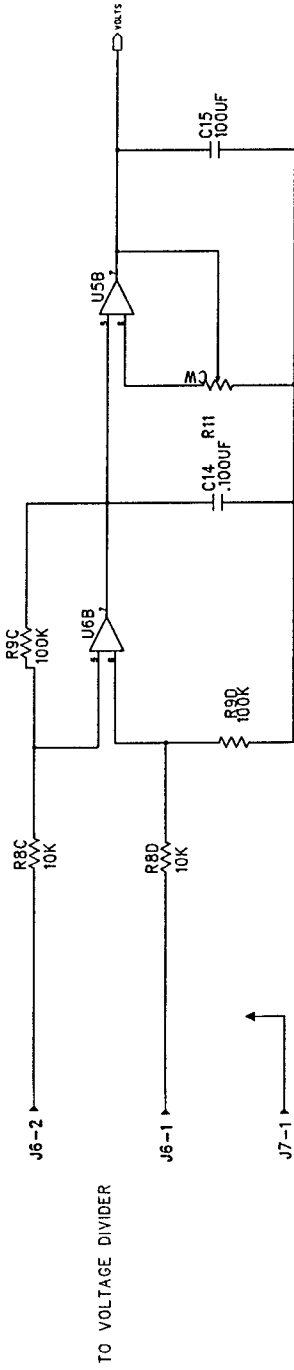
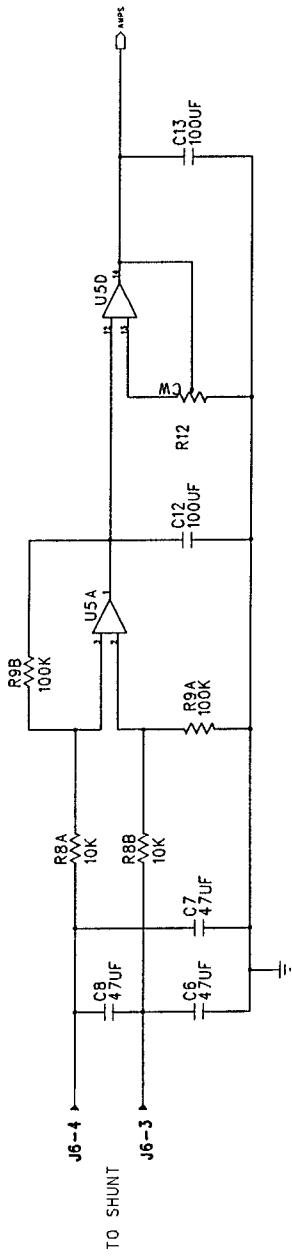

25275 VOLTAGE DIVIDER PRINTED CIRCUIT BOARD

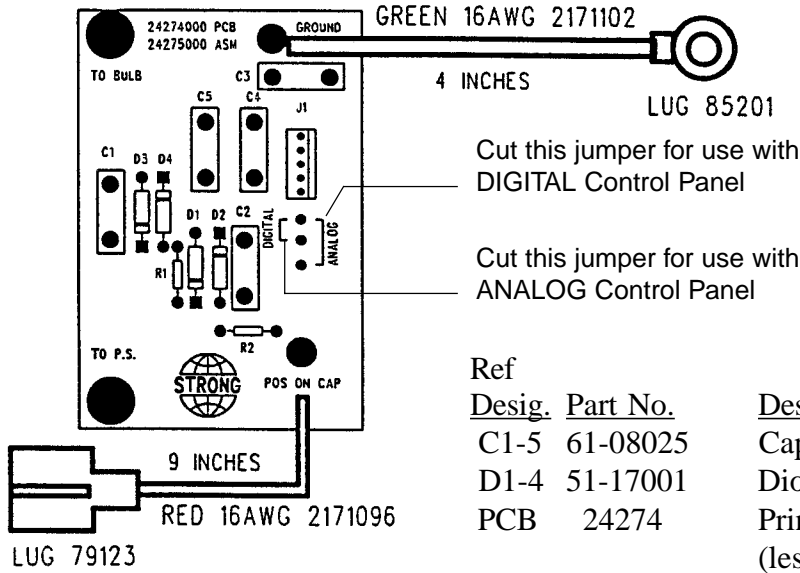

NOTE: (1) Jumper *must* be cut or PCB will not operate!

Ref

Design.	Part No.	Description
C1-5	61-08025	Capacitor, .005 μ f, 3 kV.
D1-4	51-17001	Diode, 1N4007
PCB	24274	Printed Circuit Board (less Components)
R1	61-46002	Resistor, 100 Ohm, 1/4 W. 5%
R2	61-46043	Resistor, 100k Ohm, 1/4 W. 5%
J1	21-37051	Connector, (5) Position

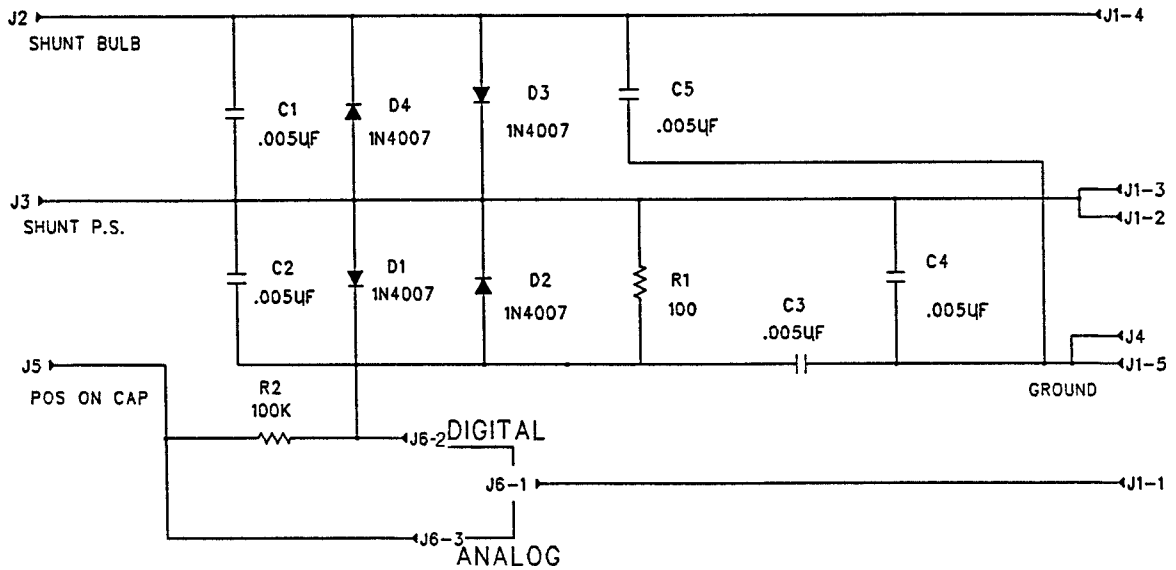

TROUBLESHOOTING

IN A NORMAL OPERATIONAL MODE, the MASTER circuit breaker at the top of the power distribution panel will be ON and lighted, and all branch circuit breakers in use will be energized. In the event of a bulb ignition failure, check first the indicator lights mounted to the (Analog) Lamp Control Panel, or the error message displayed on the (Digital) LCD screen. See the preceding DIGITAL DISPLAY section for definitions of the error messages.

INDICATOR LIGHT FUNCTIONS (Analog Controls):

- POWER “ON”** When lit, AC power is being supplied through the MASTER contactor to all branch circuits of the console. The interlock relay KI is closed, and applying voltage to wires 2 & 4. The lamphouse blowers will operate.
- LAMP “ON”** This indicator lights only when the control circuit is complete, meaning all access doors are closed and locked, the rear bulb seal blower is operating and supplying adequate air flow across the xenon bulb, and that a contact across 3 & 6 has been completed through the automation circuit. This indicator lights also when operating the lamphouse in the MANUAL mode (LAMP switch in the upper position). This light indicates that the xenon bulb is ON.
- “AIR”** Closure of the air flow switch, indicating adequate ventilation, will light this bulb. The optional 31902 Exhaust Air Vane Switch (if used) is wired to this circuit.
- “DOOR”** The (2) interlock switches, at the operator lamphouse access door and the rear door, must be closed to actuate this light. Make certain both of these doors are closed and locked.

The POWER “ON,” “AIR,” and “DOOR” indicators must all be lighted to permit ignition of the xenon bulb. LAMP “ON” lights only when the circuit for bulb ignition is complete.

The xenon power supply includes a three-pole circuit breaker, a line fuse, and a control circuit breaker not included in the lamphouse control circuit. These components are accessible through the rear door. A tripped breaker or open line fuse will also prevent xenon bulb ignition. Phase loss and/or instability in the AC supply line will also disable the xenon power supply. See the TROUBLESHOOTING section of the Xenon Power Supply Manual (Phase Loss Detection & Brown-Out Protection).

The Elapsed Time Meter records running time only when the xenon bulb is operating. This permits an accurate record of bulb life. A defective elapsed time meter will not prevent bulb ignition.



The control circuit of the X-90 operates on 115 V.AC. Exercise extreme caution when taking readings inside the console enclosure. Do not open the lamphouse enclosure until the bulb has cooled to room temperature and the power supply and igniter capacitors have drained for (10) minutes.



NORMAL OPERATION:

The 115 V.AC control circuit (2 & 4), derived through the stepdown transformer in the xenon power supply, is supplied to the lamphouse through the LAMP circuit breaker on the main distribution panel.

Control voltage must complete its circuit through all lamphouse interlock switches. Interlock switches are mounted to the lamphouse access door and the rear console doors. These doors must be closed and locked to insure switch closure. Domestic X-90 consoles utilize magnetic door switches; mechanical (pushbutton) switches are used on export models. An air vane switch, mounted to the blower outlet below the reflector, requires adequate air flow to actuate. An optional Exhaust Draft Air Vane Switch (31902), if installed, is wired in series with the standard air vane switch, and is actuated by the external exhaust system.

Two additional blowers, installed to cool user-selected accessories, are located above the lamphouse (automation compartment) and below the lamphouse (sound compartment). The four-inch blower in the automation compartment is powered by control circuit 2 & 4, and the six-inch blower in the sound compartment is wired through the ACC circuit breaker. No interlock switches are supplied for these blowers.

Xenon bulb ignition is effected by the high DC open circuit voltage generated by the xenon power supply upon start-up, and an arc supplied by the DC pulse igniter. Closure of the contactor in the xenon power supply, caused by the application of 115 V.AC by wires 5 & 6, generates the high DC open circuit voltage. Wire #2 of the lamphouse control circuit is jumpered to terminal #5 in the xenon power supply, and control wire #4, after completing the interlock switch circuit, becomes wire #6. The 115 V.AC circuit to the xenon power supply contactor is then completed by applying a dry contact closure between wires 3 & 6 (from automation or remote switching), or by placing the instrument panel LAMP switch in its ON position (manual mode).

Consoles with the older Type 62-80000 power supply using both an Analog control panel and Magnetic door interlock switches include a choke assembly (L1) on wire #6. The choke protects the magnetic switches from the current drawn by the power supply contactor. This choke is *not required* on units with Digital Controls and/or mechanical (pushbutton) interlock switches.

When the DC open circuit voltage reaches 130-140 V.DC, the DC pulse igniter assembly generates a high RF voltage arc which bridges the gap between the electrodes in the xenon bulb. One arc pulse is generally needed to initiate bulb ignition, but a "warm" or aged bulb may require two or more pulses. A delay between ignition pulses is normal; power supply capacitors require a few seconds to recharge. Once the xenon bulb has ignited, the DC voltage automatically drops to the bulb's sustaining level (20-26 V.DC), and the igniter assembly turns off.

RF suppression capacitors (C1, C2, C3) prevent the ignition pulse from interfering with sound inputs. RF suppression also prevents false cue detection by computerized automation controllers. Units with Digital Control Panels also incorporate a Voltage Divider PC Board (24275) mounted to the shunt. The RF suppression capacitors, and those on the Voltage Divider Board, do not contribute to the open circuit voltage required for xenon bulb ignition.

The xenon bulb will continue to operate until DC current is turned off by opening the connection between wires 3 & 6 or by placing the LAMP switch in the OFF position. The automation controller will open the 3 & 6 circuit upon completion of the program, or if a film break or other fault actuates its interlock protection.

Lamphouse blowers will continue to operate until turned off manually. To insure maximum bulb life, and to comply with bulb manufacturer's warranty requirements, allow lamphouse and exhaust blowers to run for at least ten minutes after extinguishing the xenon bulb.

Visible Indications of Malfunction (Analog Controls)

1. No POWER "ON" light. Check MASTER and LAMP circuit breakers. Measure AC supply at source.
2. No AIR light. Check squirrelcage blower; replace, repair, clean or lubricate as required.
3. No DOOR light. Side or rear access door open or unlocked. Defective interlock switch; check with ohmmeter for complete switch closure.
4. No LAMP "ON" light. Assuming all other indicator lights are ON, check for loose or missing connection in the 5 & 6 circuit.
5. Failure in automation circuit. Manual control, by means of placing the LAMP switch in its ON position, will override automation control.

Bulb Fails To Ignite

1. Defective xenon bulb. Check for damaged or scorched electrodes, discolored envelope or end caps. Replace if defective.
2. Xenon power supply DC output set too low. Increase DC output to bulb manufacturer's recommended nominal current level.
3. Low DC open circuit voltage from xenon power supply. Check no load voltage by holding PRESS FOR VOLTAGE switch and pressing LAMP "ON" switch. Repair or replace power supply if no load voltage does not reach 140 V.DC.
4. Faulty igniter. Arc at spark gap should be audible, and arc across bulb electrodes should be visible through arc viewing port. Repair or replace.
- 4a. Defective spark gap. Arc should produce a sharp "ping." A "hissing" sound denotes a defective spark gap. Repair or replace igniter printed circuit board.
5. Faulty automation contact. If lamp ignites by means of the LAMP "ON" switch, but fails to ignite when cued automatically, check automation controller.
6. Loose or faulty terminal connection. Visually inspect connections, particularly in AC circuit (5 & 6) and all DC connections.
7. Ignition pulse arcing to ground. Dress all igniter and bulb leads at least one-half inch (1 cm) away from grounded lamphouse components.

Bulb Goes Out During Operation

1. Blocked bulb seal blower intake or defective blower motor; flexible air duct disconnected from nozzle. Correct or replace. If optional 31902 Exhaust Air Vane Switch Assembly is installed, check for adequate exhaust draft.

Bulb Goes Out During Operation (continued)

2. Overheated thermal switch in xenon power supply. Check for unobstructed air flow through power supply; loose DC connection(s).
3. Phase loss or unstable AC input to xenon power supply. See power supply manual (Phase Loss Detection and Brown-Out Protection).
4. Faulty automation contact. If lamp operates normally in MANUAL mode, check automation controller.
5. Faulty xenon bulb. Check for darkened or damaged electrodes, discolored envelope, instability in operating current or voltage. Replace if defective.

Excessive Light Flicker

1. Defective xenon bulb. Check for cracked and/or sagging electrode.
2. Arc stabilization magnet missing or reversed. Replace or correct; painted end of magnet should point toward operator's side access door.
3. Projector shutter mis-timed. See projector manual.
4. Excessive ripple in DC current. See power supply manual.

Reduced Light Output

1. Normal bulb aging. Increase current. Do not exceed the maximum current rating specified by the xenon bulb manufacturer.
2. Defective bulb. Check for premature darkening of envelope; subnormal arc voltage.
3. Bulb defocused or misaligned. Repeat bulb alignment procedure.
4. Reflector coating peeled or discolored. Replace reflector.

Noise in Theatre Sound System During Bulb Ignition or Operation

1. Defective suppression capacitor(s) C1, C2, C3. Check with capacitor tester; replace capacitor or assembly if defective.
2. Console, power supply, or sound system improperly grounded. Connect to adequate earth ground.



NOTICE



The Strong DC Pulse Igniter stores energy in its capacitors *after* the console has been de-energized. To prevent shock, this energy can be discharged by placing the blade of an insulated-handle screwdriver across the metal end caps of the spark gap.

The Strong switching-type Xenon Power Supply employs solid state circuitry requiring sophisticated diagnostic equipment not generally available to field service personnel. If an ignition problem in the TROUBLE CHART section is traced to this unit, contact an authorized Strong International Dealer for further information.

FIGURE 1

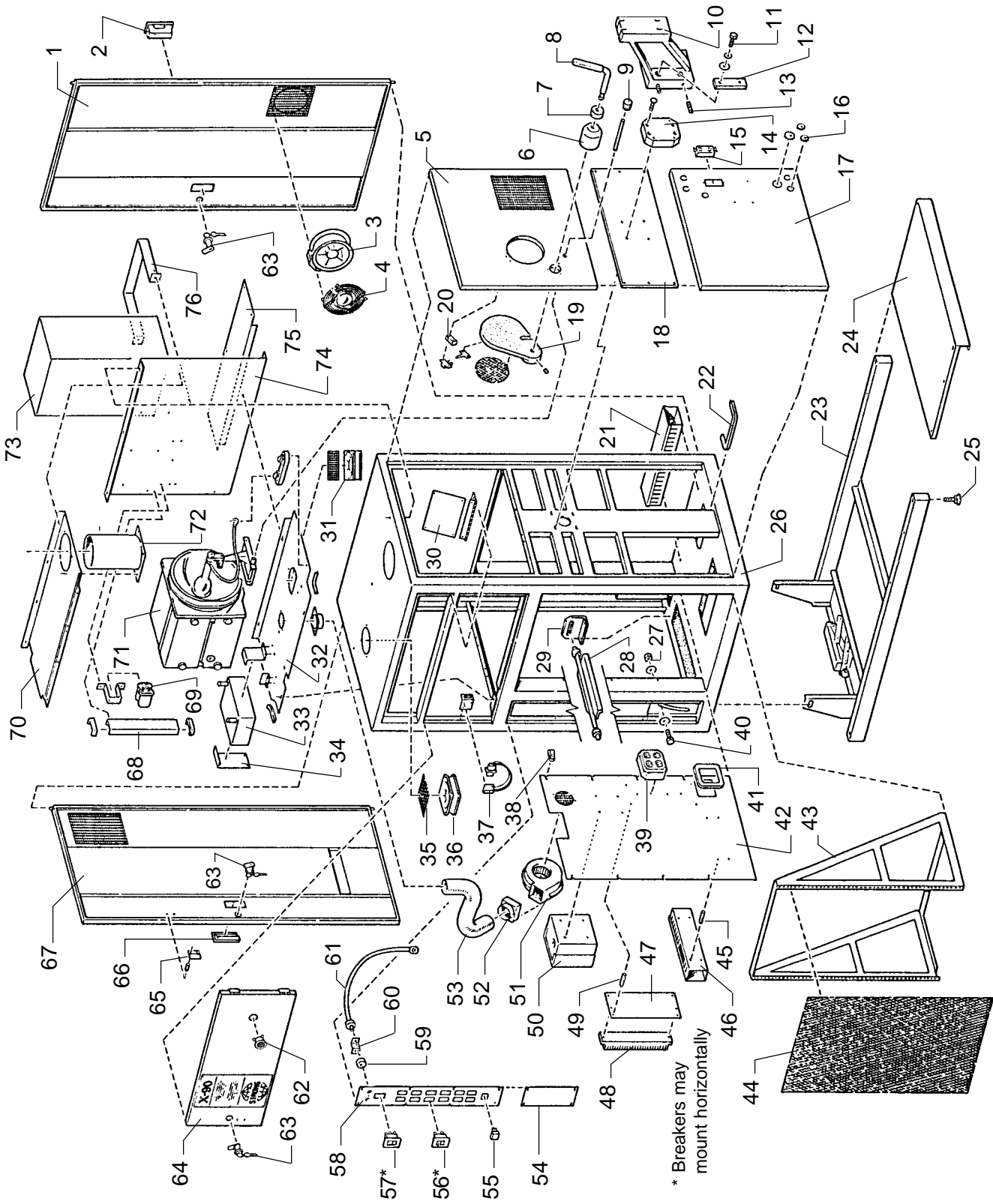

FIGURE 1
Parts List

<u>Item</u>	<u>Part No.</u>	<u>Description</u>
1	31988	Off-Operator Side Door & Hinge, Welded Assembly
2	25214	Door Handle, Recessed
3	71220	Blower, 115 V.AC, 50/60 Hz.
-	71627	Blower, 230 V.AC, 50/60 Hz. (Euro)
-	88253	Power Cord,. Blower
4	71307	Blower Grille, 6" Diameter
5	31989	Lamphouse Front Panel (Douser not included)
-	01737	Mounting Screw, 10-32 x 5/8" Hex Head
-	41-70014	Lockwasher, #10
-	41-70003	Flatwasher, #10
6	31209	Hub, Douser Shaft
7	31183	Collar, Douser Shaft
8	31184	Handle Grip, Red Plastic
-	31184	Douser Handle & Shaft
9	80193	Knob, Bulb Focus Control
-	31218	Shaft Extension, Bulb Focus
10	71226	Soundhead Mounting Arm
11	01785	Mounting Screw, 3/8-16 x 1-3/8" Hex Head (4 req'd.)
12	71240	Slide Bar (2 req'd.)
13	01784	Arm Positioning Set Screw, 3/8-16 x 1-1/2" (6 req'd.)
14	71221	Nut Plate, Soundhead Arm
-	01778	Nut Plate Mounting Screw, 5/16-18 x 1-3/4" (4 req'd.)
15	21-40240	Duplex Receptacle, Convenience Outlet
16	71202	Hole Plug, 3/4" (2 req'd.)
-	71203	Hole Plug, 1-1/4"
17	31148	Lower Front Cover
-	01737	Mounting Screw, 10-32 x 5/8" Hex Head
-	41-70014	Lockwasher, #10
-	41-70003	Flatwasher, #10
18	31151	Soundhead Arm Mounting Plate
-	01544	Mounting Screw, 1/4-20 x 1" Socket Head (6 req'd.)
-	00805	Hex Nut, 1/4-20 (6 req'd.)
19	31186	Douser Plate, Cast Aluminum
-	41-51188	Set Screw, 1/4-20 x 5/8" (2 req'd.)
-	31259	Screen. Douser Plate Heat Sink

FIGURE 1, Parts List (continued)

<u>Item</u>	<u>Part No.</u>	<u>Description</u>
20	31217	Spacer Block, Douser Catch
-	31890	Douser Catch Assembly
21	71384	Cover, Wiring Trough
-	31239	Wiring Trough, Panduit
22	21-98489	Rubber Edge Protector (Order by Foot)
23	31949	Console Base & Legs, Welded Assembly
24	31155	Cover, Base Legs
25	71184	Leveling Foot (4 req'd.)
26	31981	Console Frame, Welded Assembly
-	31129	Pivot Shaft (not shown)
27	00992	Hex Nut, 1/2-13 (2 req'd.)
-	00856	Flatwasher, 1/2" I.D. (2 req'd.)
28	31993	Jack Swivel, Welded Assembly
29	31135	Jack Swivel Mounting Bracket (2 req'd.)
30	---	Control Panel (see Figure 3)
-	31953	Control Panel Hinge Assembly
31	61-98002	Front Bulb Seal Blower (B2), 115 V.AC, 50/60 Hz.
32	31417	Lamphouse Base Plate (see Figure 2)
33	39862	DC Pulse Igniter
-	39875	Igniter Case & Coil, Potted Assembly
-	62-87004	Igniter Printed Circuit Board Assembly
34	31411	Igniter Clamping Bracket, Rear
35	83131	Blower Grille, 4" Square (2 req'd.)
36	61-98002	Automation Compartment Blower (B3), 115 V.AC, 50/60 Hz.
37	24406	Door Interlock Switch Assembly (S1), Magnetic
-	39260	Door Interlock Switch, Pushbutton (Euro)
38	41-10011	Nylon Cable Clamp, 3/4" (7 req'd.)
39	31944	AC Receptacle Assembly, Sound/Accessory Compartment (2 req'd.)
40	01472	Tilt Lock Screw, 1/2-13 x 1" Hex Head (2 req'd.)
-	00856	Flatwasher, 1/2" I.D. (2 req'd.)
41	21-98489	Rubber Edge Protector (Order by Foot)
42	31937	Divider Plate
43	31999	Sound & Accessory Rack, Welded Assembly
44	71462	Filler Panel, Perforated Steel
45	41-56001	Hex Spacer, 1" Threaded 8-32 (4 req'd.)
46	31205	Wire Trough, Panduit
-	31207	Cover, Wire Trough
47	31132	Terminal Board Mounting Plate

FIGURE 1, Parts List (continued)

<u>Item</u>	<u>Part No.</u>	<u>Description</u>
48	31868	Terminal Block Assembly (TB1)
49	41-56001	Hex Spacer, 1" Threaded 8-32 (4 req'd.)
50	21-14001	Master Contactor (KM), 115 V.AC Coil
-	71775	Master Contactor (KM), 230 V.AC Coil (Euro)
-	71776	Enclosure Box for 71775
51	31206	Rear Bulb Seal Blower (B1), 115 V.AC, 50/60 Hz.
52	31987	Blower Outlet Nozzle
53	31213	Flexible Air Duct, 2" Diameter x 18" Long
54	31163	Filler Plate
55	21-21044	Cap, Fuseholder (early models)
-	21-21043	Fuseholder (early models)
-	21-21016	Fuse, 1 Amp. Standard (as required)
56*	24348	Switching Circuit Breaker, MASK 1; 15 Ampere
-	24347	Switching Circuit Breaker, LAMP; 10 Ampere
-	24347	Switching Circuit Breaker, PROJ; 10 Ampere
-	24245	Switching Circuit Breaker, AUTO; 5 Ampere
-	24346	Switching Circuit Breaker, SND 1; 20 Ampere
-	24346	Switching Circuit Breaker, SND 2; 20 Ampere
-	24346	Switching Circuit Breaker, SND 3; 20 Ampere
-	24348	Switching Circuit Breaker, MASK 2; 15 Ampere
-	24348	Switching Circuit Breaker, CURT; 15 Ampere
-	24347	Switching Circuit Breaker, TRANS; 10 Ampere
-	24347	Switching Circuit Breaker, ACC; 10 Ampere
-	24347	Switching Circuit Breaker, SLIDE; 10 Ampere
57*	24245	Switching Circuit Breaker, MASTER; 5 Ampere
58*	25265	Panel, Silk Screened (less Components)
-	25266	Distribution Center Assembly (Items 56-58), Current Production
-	31936	Distribution Center Assembly (Items 56-58), Old Style (as shown)
-	31326	Distribution Center Assembly (Euro model; see Figure 4)
59	71400	Collar, Remote Control Cable (2 req'd.)
60	31248	Angle Bracket, Cable Mount (2 req'd.)
61	71937	Remote Control Cable Assembly (2 req'd.)
62	48930	Arc Viewing Port
63	71284	Cam Lock & Keys
64	31991	Lamphouse Access Door & Hinge, Welded Assembly
-	31238	Name & Data Plate
65	21-61007	Magnetic Actuator, Door Interlock Switch
-	31-98002	Hex Spacer (2 req'd.)
	*	Breakers mounted <i>horizontally</i> on 25266 Panel Assembly

FIGURE 1, Parts List (continued)

<u>Item</u>	<u>Part No.</u>	<u>Description</u>
66	25214	Door Handle, Recessed
67	31992	Rear Door & Hinge, Welded Assembly
68	31278	Wire Channel, Stainless Steel
69	76323	RF Suppression Capacitor (C2,C3); 2 req'd.
-	76208	Capacitor Mounting Strap
70	31942	Automation Shelf, Welded Assembly
-	31893	Hinge, Automation Panel (not shown)
71	---	See Figure 2
72	31928	Exhaust Stack, 6" Diameter; Welded Assembly
73	62-80100*	Xenon Power Supply
74	31118	Lamphouse/Power Supply Partition Plate, Stainless Steel
75	31108	Power Supply Floor Plate, Stainless Steel
76	25350	Power Supply Restraining Strap Assembly
	*	Order Replacement by <i>Equipment Type Number</i> on Data Plate
		NOT SHOWN
	31433	Nose Cone, Welded Assembly

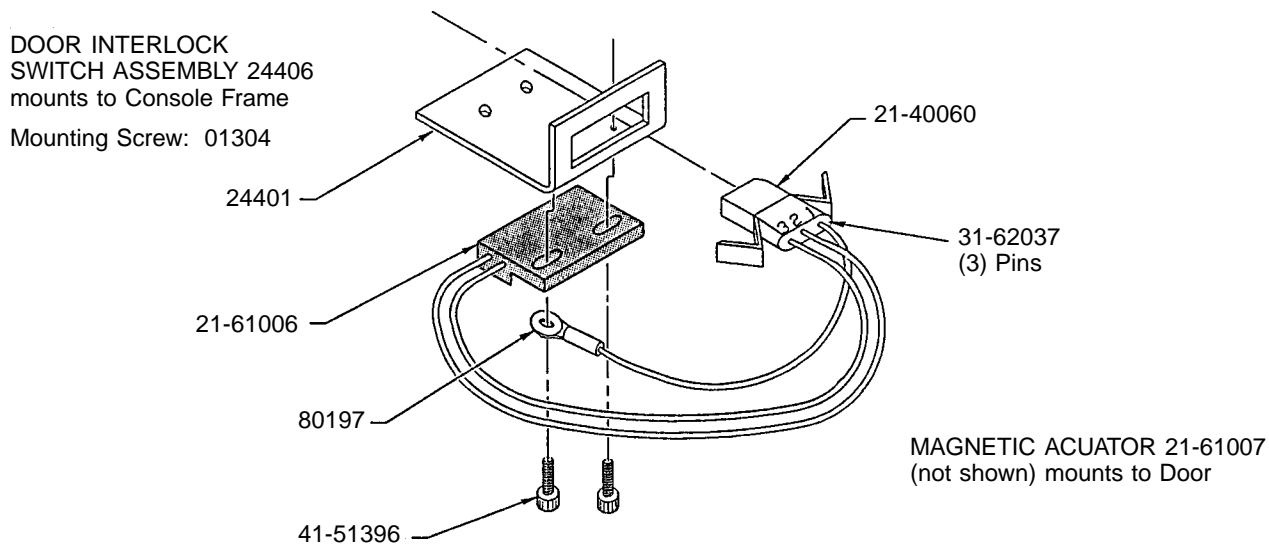

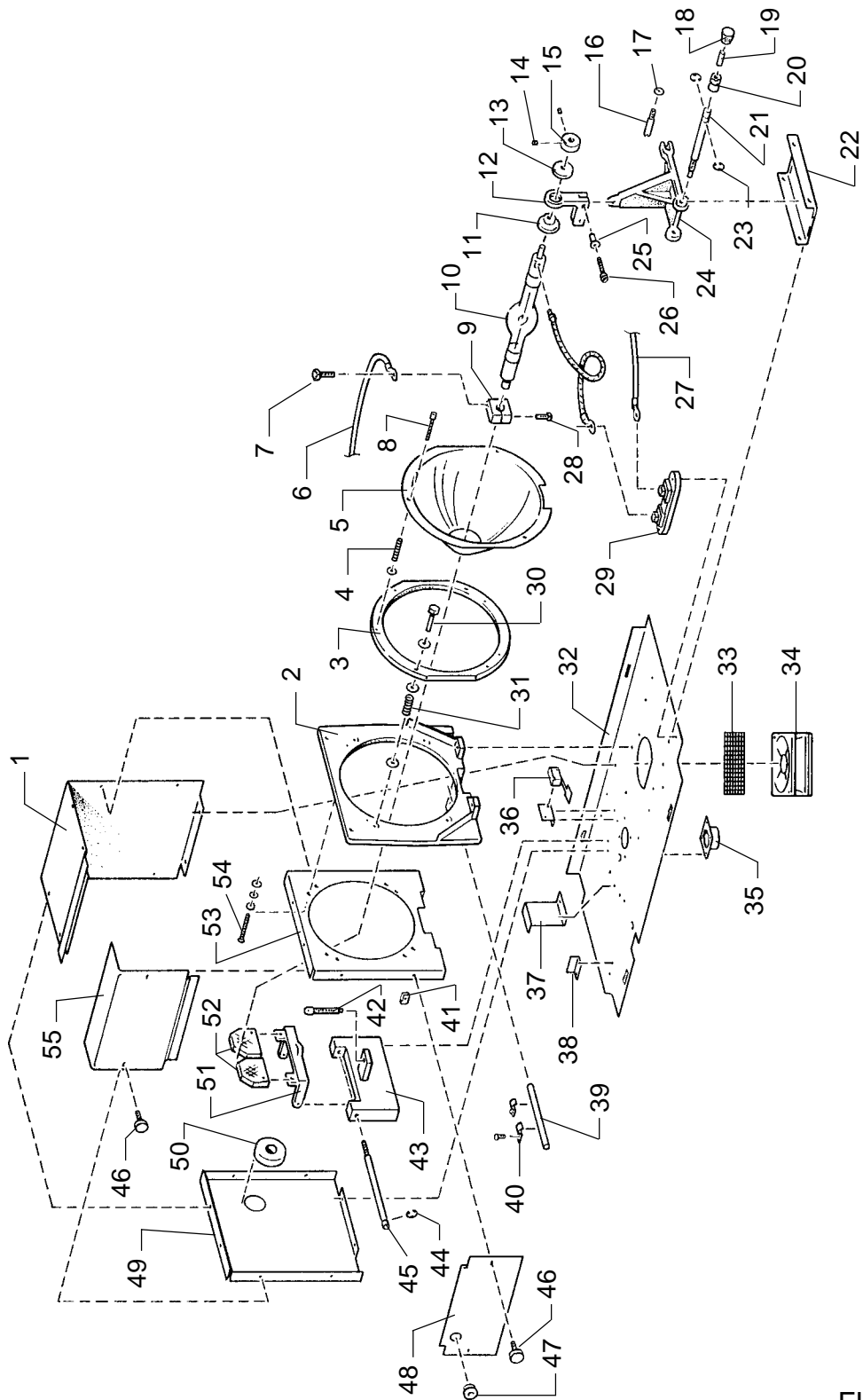

FIGURE 2

FIGURE 2
Parts List

<u>Item</u>	<u>Part No.</u>	<u>Description</u>
1	31982	Bulb Enclosure, Top & Inner Side
2	31369	Reflector Bulkhead Casting
3	65435	Reflector Adapter Ring
4	21-58001	Compression Spring (3 req'd.)
-	41-70003	Flatwasher, #10 (3 req'd.)
5	23755	Flanged Reflector, 11" Dichroic Coated
6	31865	DC Wire Harness Assembly (ref. Item 27)
7	00685	Screw, 1/4-20 x 3/8" Hex Head
8	18194	Shoulder Bolt (3 req'd.)
9	65410	Contact Clamp, 2 kW (as shown*)
10	---	Xenon Bulb (by Customer)
11	71242	Flanged Insulator Washer, 2 kW (as shown*)
12	31245	Anode Support Casting
13	71241	Insulator Washer, 2 kW (as shown*)
14	01598	Set Screw, 8-32 x 1/4"
15	81389	Collar, 2 kW (as shown*)
16	71214	Outrider Shaft, Support Pedestal
17	00889	Lockwasher, 1/4" Internal Tooth
18	80193	Knob, Bulb Focus Control
19	31218	Focus Shaft Extension
20	51-16002	Flexible Coupler
21	71636	Bulb Focus Shaft, Threaded
22	31368	Front Pedestal Support Bracket
23	94129	External Snap Ring (2 req'd.)
24	31322	Front Bulb Support Pedestal
25	71099	Pivot Bushing, Support Casting
26	41-51107	Screw, 10-32 x 7/8" Fillister Head
27	31865	DC Wire Harness Assembly (ref. Item 6)
28	01532	Clamping Screw, 8-32 x 7/8" Socket Head
29	82167	Shunt (R1)
30	41-51125	Ring Mounting Screw, 1/4-20 x 7/8" Hex Head (3 req'd.)
31	P-3055	Compression Spring (3 req'd.)
-	41-70004	Flatwasher, 1/4" (6 req'd.)

* 2000 Watt Bulb & Adapters shown; see XENON BULB ADAPTERS (page10) for other sizes.

FIGURE 2, Parts List (continued)

<u>Item</u>	<u>Part No.</u>	<u>Description</u>
32	31417	Lamphouse Base Plate
33	31367	Blower Grille
34	61-98002	Front Bulb Seal Blower (B2), 115 V.AC, 50/60 Hz.
-	83131	Blower Grille, Plastic (not shown)
35	31948	Blower Inlet Nozzle
36	85109	Air Flow Switch (S3)
-	39188	Air Paddle, Switch Actuator Arm
-	12-30583	Switch Mounting Bracket
37	31173	Igniter Clamping Bracket
38	31412	Igniter Retaining Bracket
39	39215	Arc Stabilization Magnet
40	41-10004	Magnet Clamp (2 req'd.)
41	01507	Tinnerman Nut, #10 (4 req'd.)
42	81134	Threaded Stud, Vertical Adjustment
43	31877	Rear Bulb Support Pedestal
44	94129	External Snap Ring (2 req'd.)
45	81133	Threaded Shaft, Horizontal Adjustment
46	31875	Thumb Screw, 10-32 (4 req'd.)
47	31-07001	Heyco Bushing
48	31409	Bulb Enclosure, Lower Cover
49	31406	Bulb Enclosure, Rear Panel
50	31410	Inuslator Bushing, Nylon
51	71247	Cathode Block Base Casting
52	71676	Cathode V Block Segment (2 req'd.)
-	71675	Cathode V Block, 2.5 kW, 2 kW "HS" (not shown)
-	81336	Spacer Block for 71675; 2.5 kW, 2 kW "HS" (not shown)
53	31405	Bulb Enclosure, Front Bracket
54	00265	Reflector Ring Stop Screw, 8-32 x 1-1/4" (4 req'd.)
55	31419	Bulb Enclosure, Access Panel

FIGURE 3

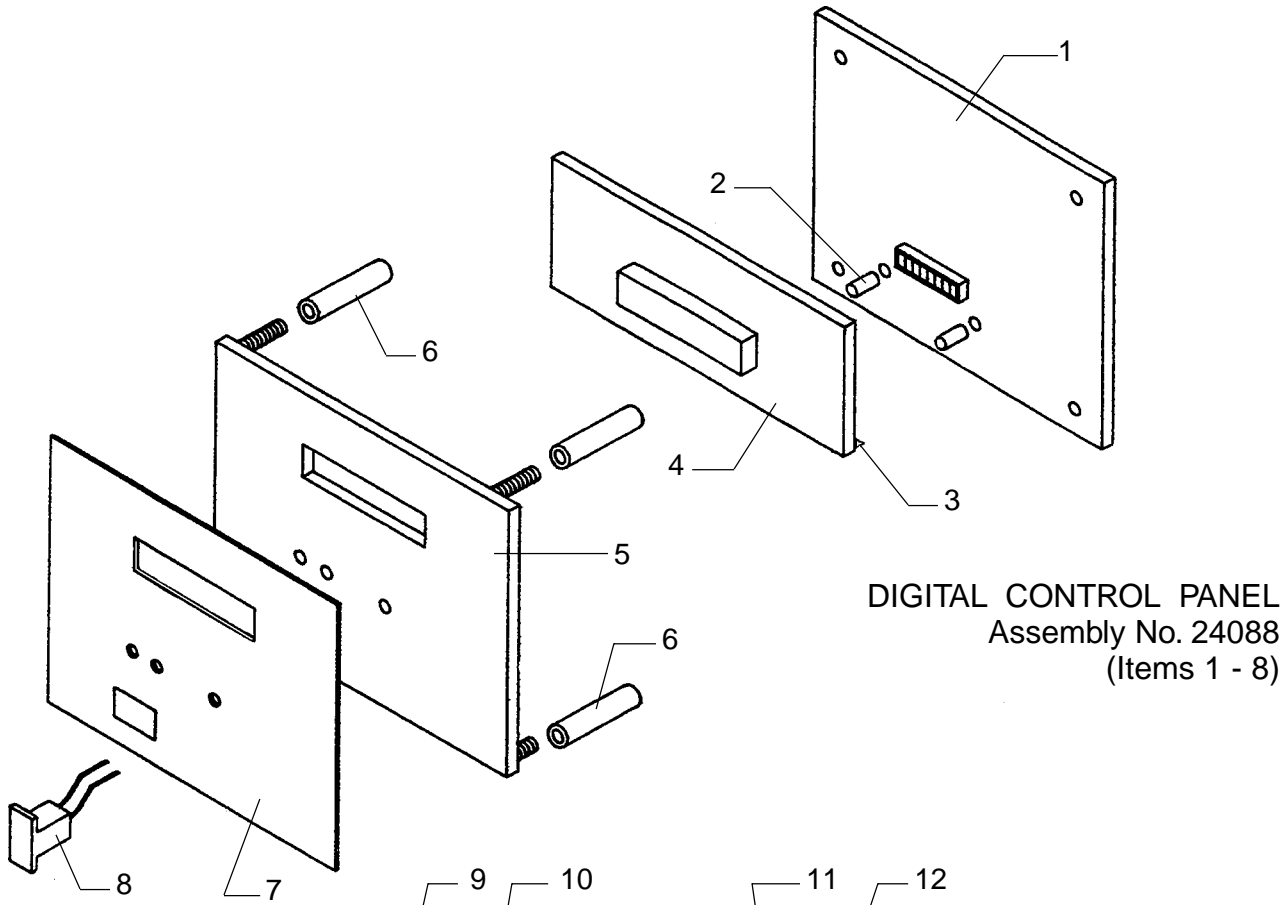

ANALOG CONTROL
 PANEL
 Assembly No. 31946
 (Items 9 - 15)

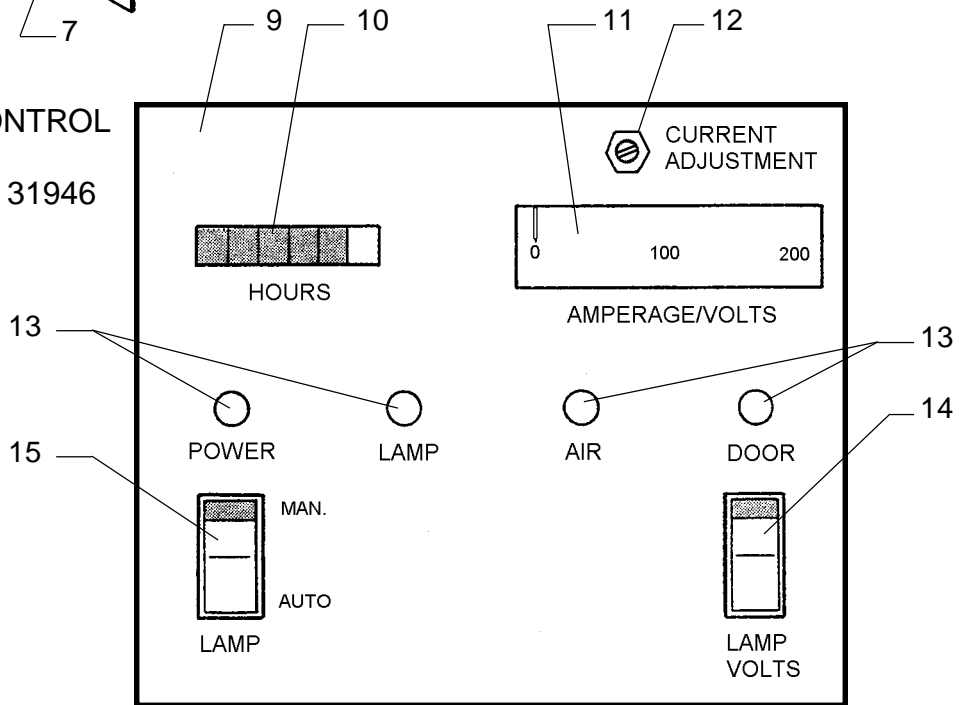
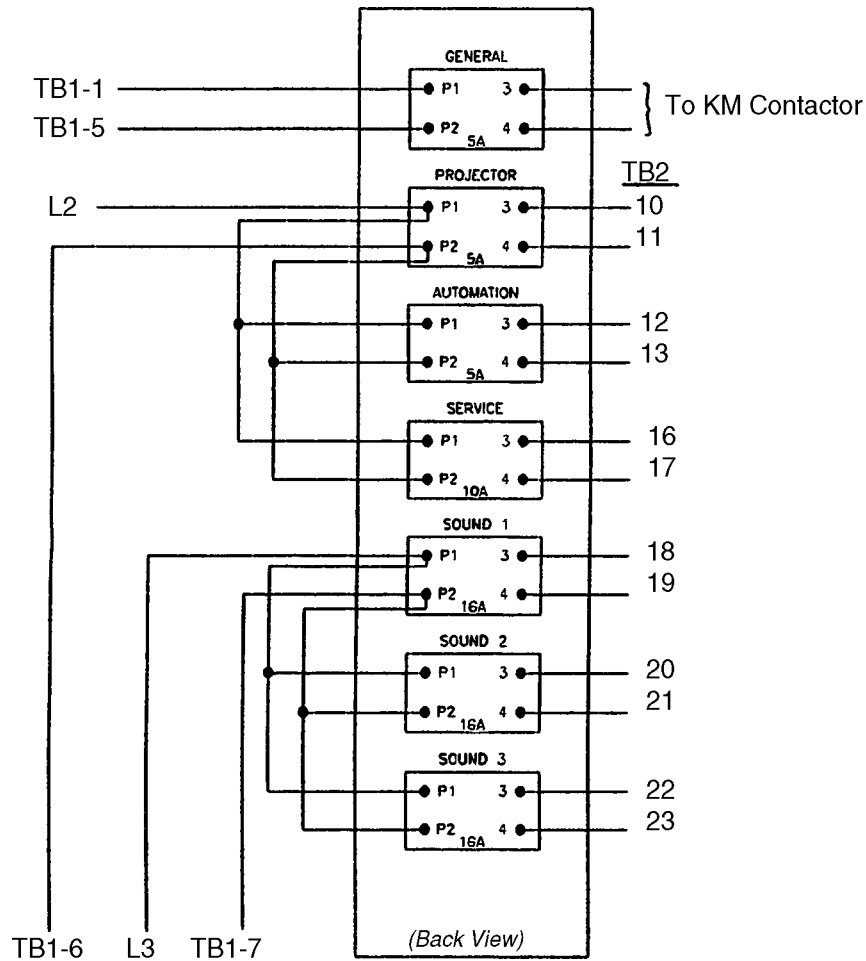

FIGURE 3
Parts List

<u>Item</u>	<u>Part No.</u>	<u>Description</u>
1	23976	Printed Circuit Board Assembly, Digital Control
2	61-98022	Standoff, 6-32 x 1/2" Brass (2 req'd.)
3	71-40019	Pin Header
4	24087	LCD Display Assembly
5	23975	Control Panel Plate (less Components)
6	21-98543	Standoff, 1-1/8" Aluminum (4 req'd.)
7	23927	Overlay, Adhesive Backed
8	24086	LAMP Switch Assembly
9	31122	Control Panel Plate (less Components)
10	2479-1216	Elapsed Time Meter, 60 Hz.
10	2479-1215	Elapsed Time Meter, 50 Hz. (Euro)
11	40191	Ammeter, 0-200 A. 50 mV.
12	62-70032	Current Control & Cable Assembly
-	61-69002	Potentiometer (only), 10k Ohm
13	81-30002	Light Emitting Diode (4 req'd.)
-	7056-0007	Green Cap
14	23868	Rocker Switch, Momentary
15	23869	Rocker Switch, LAMP
-	24236	Printed Circuit Board Assembly (incl. Items 13.14. & 15)

FIGURE 4



<u>Part No.</u>	<u>Description</u>
31326	Euro Distribution Panel Assembly
31343	Distribution Panel Plate (less Components)
71929	Switching Circuit Breaker, 5 Ampere
71630	Switching Circuit Breaker, 10 Ampere
71660	Switching Circuit Breaker, 16 Ampere
71775	Master Contactor (KM); see Figure 1, Item 50
71776	Contactor Enclosure (for 71775)
31338	Wire Harness, Door Interlock Switches
31869	Transformer Assembly, Euro X-90

