

Film-Tech

The information contained in this Adobe Acrobat pdf file is provided at your own risk and good judgment.

These manuals are designed to facilitate the exchange of information related to cinema projection and film handling, with no warranties nor obligations from the authors, for qualified field service engineers.

If you are not a qualified technician, please make no adjustments to anything you may read about in these Adobe manual downloads.

www.film-tech.com

INSTRUCTION MANUAL

ELECTRIC DOUSER KIT

for Strong Lamphouses

3-91



STRONG INTERNATIONAL, Inc.
4350 McKinley St. Omaha, NE 68112
402/453-4444 FAX 402/453-7238

CONTENTS

Installation Instructions	
Highlight Consoles	1
Super 80	1
Super Lume-X	2
X-90 Console	3
Figures A, B (Illustrations)	4
Figure C (Illustration)	5
Wiring Instructions	6
Wiring Diagram	7
Parts List	8

STRONG INTERNATIONAL, INC.

Engineering/Sales

March, 1991

ELECTRIC DOUSER KIT
Installation Instructions

THE ELECTRIC DOUSER is designed for use with the Strong Super Lume-X and Super 80 projection lamphouses, and all models of Strong projection consoles. The kit is factory mounted when ordered with new equipment, or available as a field retrofit for existing installations.

WHEN INSTALLED, the Electric Douser Kit automatically opens the lamphouse douser when the projector motor starts, and closes the douser when the projector motor shuts down. The Electric Douser Kit operates independently from the lamphouse control and ignition circuits. This circuit logic permits continuous operation of the xenon bulb during intermittent projection cycles, thus prolonging useful bulb life.

THREE KITS are available for the desired application. Figure A shows the kit for the Super 80 lamphouse and Highlight consoles. Figure B illustrates the Super Lume-X kit, and Figure C, the X-90 kit. The differences between the kits are mechanical, to permit mounting to the various lamps. Electrical wiring is very similar. Wiring instructions and a diagram follow on pages 6 and 7.

FIGURE A - Super 80, Highlight Consoles

Dismount the douser plate from the existing douser shaft by removing the set screw and the shoulder screw from the plate casting. Withdraw the existing douser shaft, and retain the torsion spring and mounting hardware. Insert the replacement douser shaft (Fig. A, Item 1) and reinstall the douser plate and torsion spring.

Remove the cover (Fig. A, Item 3) from the motor assembly (Fig. B, Item 4). **Retain the 3/16" mounting screw. Use of a longer screw will damage the motor.** Mount the bracket (Fig. A, Item 5) to the motor assembly (Fig. A, Item 4) using the hardware supplied (Fig. A, Item 6). Leave the fasteners fingertight in the bracket slots for adjustment.

Slide the motor assembly (Fig. A, Item 4) over the machined end of the douser shaft (Fig. A, Item 1). Align the coupler set screw (Fig. A, Item 7) to the flat machined in the end of the douser shaft. Press the motor assembly slightly against the shaft to compress the metal collars against the rubber. Temporarily tighten the coupler set screw.

Place the bracket (Fig. A, Item 5) against the front of the lamphouse to locate the mounting holes. Open and close the douser handle to make certain there is no bind in the operation. Mark the locations of the mounting holes, and remove the motor assembly. The mounting holes may then be drilled 5/32" and tapped 10-32, or drilled 3/16" for #10 screws and hexnuts.

Remount the motor assembly to the douser shaft, compress the coupler, and secure the coupler set screw to the flat on the douser shaft. Install the bracket mounting hardware to the front of the lamphouse, and open and close the douser. Secure all mounting fasteners at the point at which the douser operates without binding. Replace the motor cover (Fig. A, Item 3) after wiring using the original 3/16" screw. See WIRING INSTRUCTIONS.

FIGURE B - Super Lume-X Lamphouse

Dismount the douser plate from the existing douser shaft, keeping all mounting hardware and spacers. Remove and discard the catch assembly. Replace the screws and nuts in the front casting to prevent light leakage. Loosen the set screws in the shaft collars, and withdraw the existing douser shaft. Retain the collars and torsion spring.

Insert the replacement douser shaft (Fig. B, Item 1), passing it through the collar/torsion spring/collar in sequence. Remount the douser plate to the douser shaft. Center the douser plate covering the opening in the lamphouse snood, and secure the collars to the douser shaft. The collars should be located near the front casting to minimize end play, but should permit free operation of the douser handle in opening and closing the douser completely.

Remove the motor cover (Fig. B, Item 3) from the motor assembly (Fig. B, Item 4). **Retain the 3/16" mounting screw. Use of a longer screw will damage the motor.** Remove the nut plate (Fig. B, Item 6) from the mounting bracket (Fig. B, Item 5). Mount the bracket to the motor assembly using the mounting hardware (Fig. B, Item 7).

Mount the motor assembly (Fig. B, Item 4) to the machined end of the douser shaft (Fig. B, Item 1), aligning the coupler set screw (Fig. B, Item 8) to the flat on the machined end of the douser shaft. Press the motor assembly slightly into the douser shaft to compress the metal and rubber coupler collars. Temporarily tighten the set screw (Fig. B, Item 8).

Position the mounting bracket against the side of the lamphouse. Operate the douser open and closed, and locate the (2) bracket mounting holes at the point at which the douser operates freely. Remove the motor assembly, and drill (2) 3/16" holes at the hole locations marked.

Remount the motor assembly to the douser shaft, slightly compress the coupler collars, and secure the coupler set screw (Fig. B, Item 8) to the flat on the machined end of the douser shaft. Position the nut plate (Fig. B, Item 6) inside the lamphouse aligned to the mounting holes drilled, and secure the motor mounting bracket to the side of the lamphouse. Replace the motor cover (Fig. B, Item 3) after wiring using the original screw. See WIRING INSTRUCTIONS.

FIGURE C - X-90 Console

Loosen the (2) set screws in the hub of the douser plate and dismount the douser plate. Remove the (3) pan head screws and dismount the existing douser handle assembly. Retain the (3) screws.

Mount the douser drive assembly (Fig. C, Item 7) to the console in place of the former douser handle assembly. The lever should be on the operator's side of the console.

When shipped as a field retrofit kit, the motor assembly, the motor cover, and the gear train are preassembled (Fig. C, Item 1). Mount the gear train and motor bracket (Fig. C, Item 3) to the console using the mounting holes aligned to the top and center socket head cap screws (operator's side) securing the projector arm mounting plate to the console frame (See X-90 Manual, Fig. 1, Item 7). The knob (Fig. C, Item 2) should be on the operator's side. Mount the motor and drive train assembly to the bracket using the (2) mounting screws (Fig. C, Item 4), and connect the gear train to the douser lever using pin (Fig. C, Item 6).

Rotate the knob (Fig. C, Item 2) counterclockwise to the lower stop. Replace the douser plate and secure in the full closed (uppermost) position, with the catch engaged. Rotate the knob clockwise to the upper stop and make certain the douser plate is in the full open position. If not, adjust the operating shaft locknut (Fig. C, Item 5) to fully open the douser. Reverse knob rotation to recheck closed position. Remove the catch from the douser plate.

Remove pin (Fig. C, Item 6) to detach the douser drive. Loosen the collar set screw (Fig. C, Item 8). Rotate the collar to preload the internal torsion spring to balance the weight of the douser plate. When the douser plate is balanced, tighten the collar set screw, and reattach the pin.

See WIRING INSTRUCTIONS.

NOTE: When removing the motor cover, retain the 3/16" mounting screw. Use of a longer screw will damage the motor.

ELECTRIC DOUSER INSTALLATION

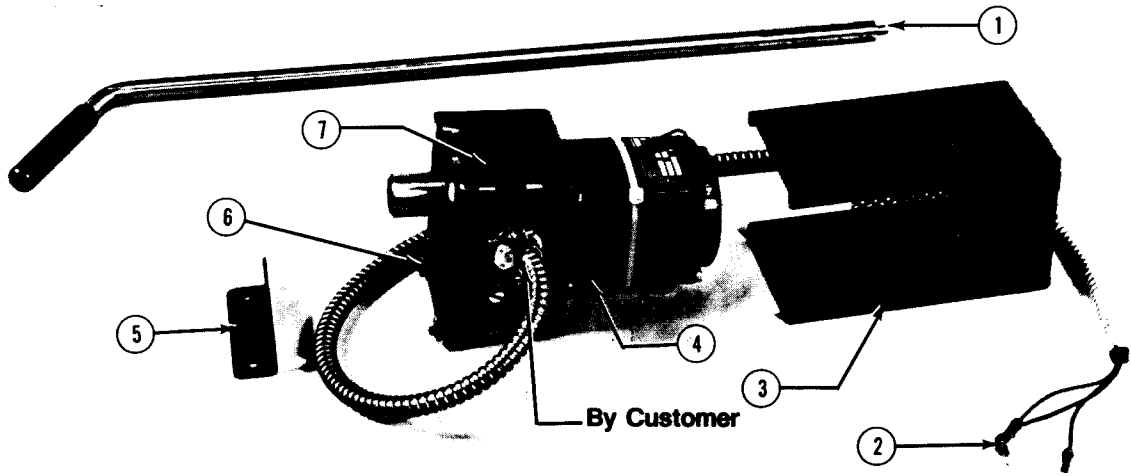

FIGURE A

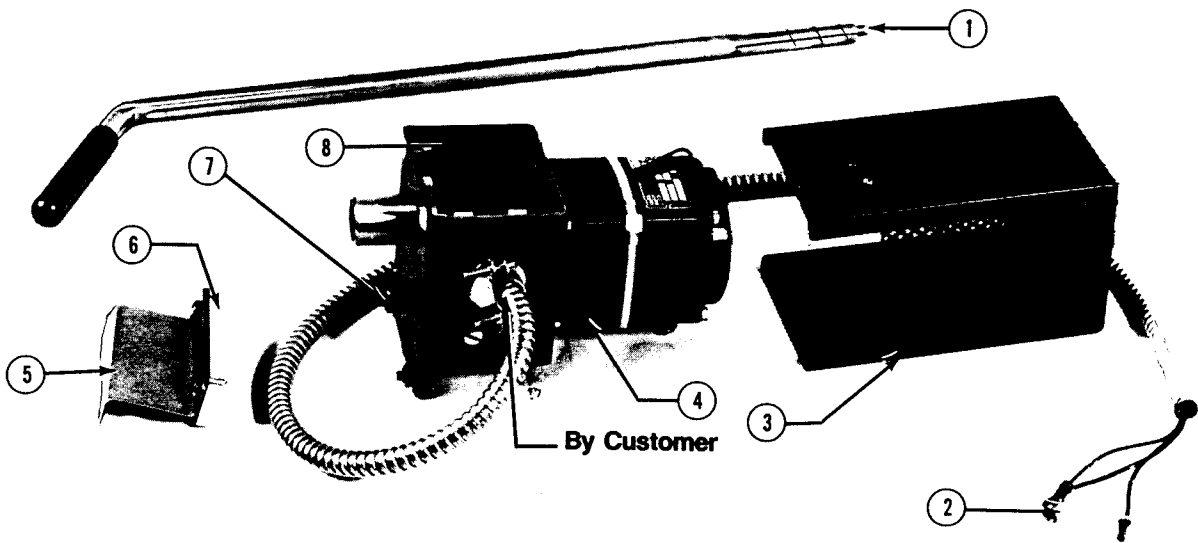

FIGURE B

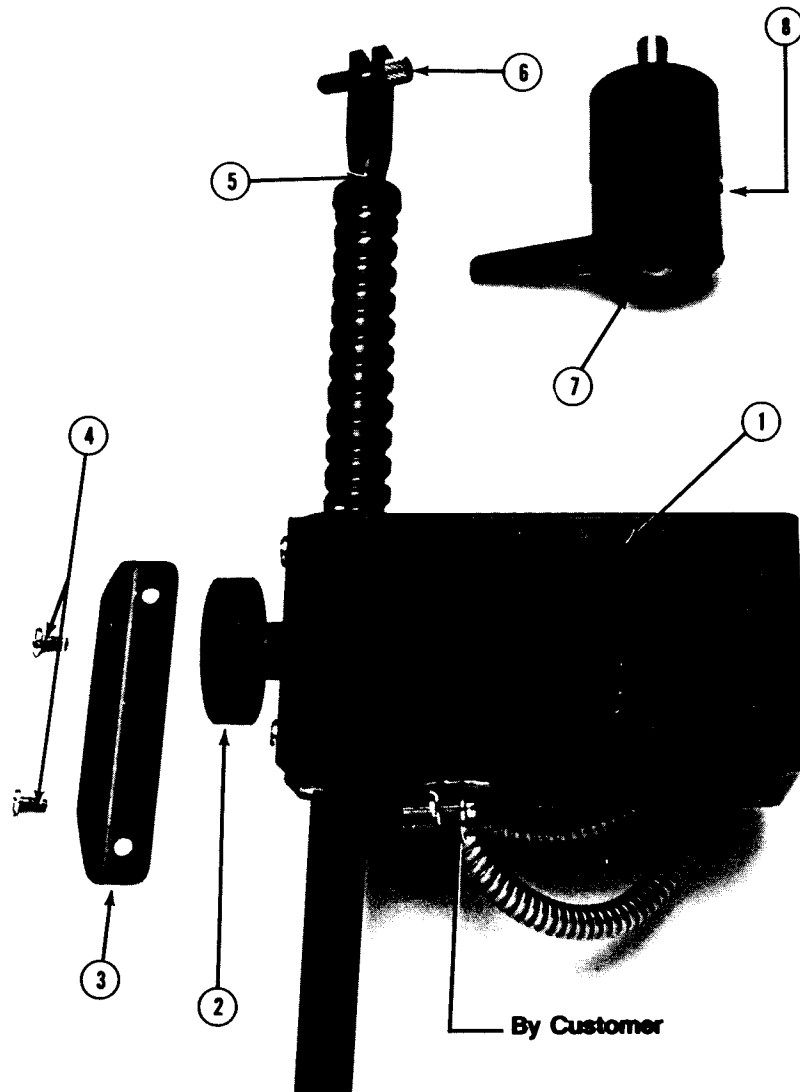

FIGURE C

STRONG INTERNATIONAL, Inc.
4350 McKinley St. Omaha, NE 68112
402/453-4444 FAX 402/453-7238

WIRING INSTRUCTIONS

Electric Douser Kit

Electrical connections to the electric douser motor are made to the terminal block exposed by removing the motor cover. **Use only the 3/16" screw supplied to mount the motor cover. Use of a longer screw will damage the motor.** The motor operates at 120 V.AC, single phase, 60 Hertz.

The drive motor is a constant stall torque type, and will hold the douser in either the OPEN or CLOSED position as long as the motor is energized. A prewired toggle switch, mounted to the motor assembly, permits turning the electric douser OFF for manual douser operation.

Control wires (and conduit, as required) are supplied by the installer, as wire lengths and routing are determined by the individual application. See the illustrations for a "By Customer" example. All wiring must comply with local codes.

The motor leads terminated at the terminal block are blue, black, and red. The blue lead must be connected to the neutral (white) wire of the douser control circuit. Connection of the douser circuit phase to the black or blue leads determine the rotation of the torque motor. When installing a Super Lume-X, Super 80, or Highlight console kit (Figures A or B), apply phase to the **black** lead for **douser OPEN**, and to the **red** lead for **douser CLOSE**. The X-90 kit (Figure C) requires phase on the **red** lead for **douser OPEN**, and on the **black** lead for **douser CLOSE**. A ground wire, if required, may be terminated at the terminal block mounting screw.

Switching provisions of the automation or a relay, supplied by the installer, can be used to establish the operating logic. It is recommended to fuse the phase side of the AC line at (1) ampere. See the attached wiring diagram.

MAINTENANCE

The torque motor is sealed and requires no lubrication. A slight heat rise is natural when the motor is operating; keep the cover grilles clean to permit adequate air exchange.

Periodically check all fasteners for tightness.

WIRING DIAGRAM

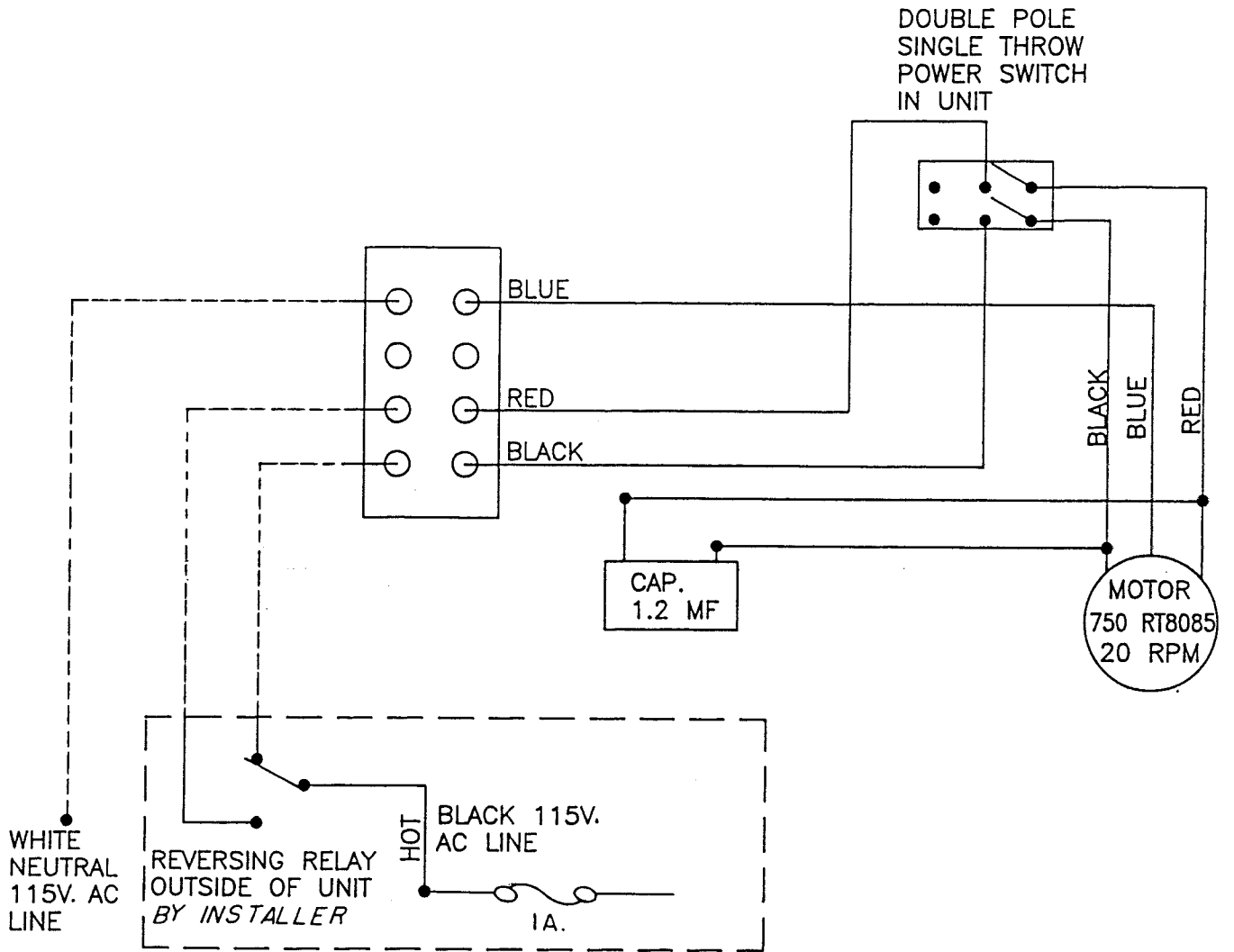

See WIRING INSTRUCTIONS, p. 6

PARTS LIST

<u>Part No.</u>	<u>Description</u>
71754	Electric Douser Kit, Highlight Consoles
40914	Electric Douser Kit, Super 80
39871	Electric Douser Kit, Super Lume-X
31871	Electric Douser Kit, X-90 Console
51-33008	Torque Motor, 120 V.A.C.
--	Coupler
22-21051	Coupler Collar
22-40862	Coupler Cushion, Rubber
21-37042	Coupler Pin, 3/16 x 7/8"
41-51187	Set Screw, 1/4-20
71794	Coupler Housing
21-61144	Toggle Switch
71752	Support Hub & Bearing Ass'y.
71793	Motor Cover, Welded Ass'y.
71623	Douser Shaft, Highlight Consoles
71645	Douser Shaft, Super 80
71644	Douser Shaft, Super Lume-X
71618	Motor Mounting Bracket, Highlight Consoles
71619	Motor Mounting Bracket, Super 80
71643	Motor Mounting Bracket, Super Lume-X
71624	Bracket Nut Plate, Super Lume-X
31308	Hand Knob (X-90 Kit)
21-04003	Ball Bearing
21-23013	Gear, 15 Tooth
31317	Mounting Block
31307	Douser Shaft
31309	Douser Shaft Hub
31311	Douser Spring Housing
31312	Torsion Spring
31313	Spring Housing Cover
31318	Mounting Bracket
71625	Rack Gear
31890	Upper Rack Cover
31895	Lower Rack Cover
31305	Stop Collar
31310	Pin, Douser Lever