

Film-Tech

The information contained in this Adobe Acrobat pdf file is provided at your own risk and good judgment.

These manuals are designed to facilitate the exchange of information related to cinema projection and film handling, with no warranties nor obligations from the authors, for qualified field service engineers.

If you are not a qualified technician, please make no adjustments to anything you may read about in these Adobe manual downloads.

www.film-tech.com

INSTRUCTION MANUAL

BALLANTYNE PRO-35

35mm Projector Mechanism

Rev. 2/98



**STRONG
INTERNATIONAL**

a division of Ballantyne of Omaha, Inc.
4350 McKinley Street
Omaha, Nebraska 68112 USA
Tel 402/453-4444 • Fax 402/453-7238

CONTENTS

Preface	1
Receiving & Installation	2
Threading	4
Projection Lens Installation	5
Maintenance	6
Operator Adjustments	
Pad Rollers	7
Shutter Timing	8
Framing Tension	9
Intermittent Sprocket Alignment	9
Intermittent Movement	10
Framing Coupler	11
Parts Catalog	12

PREFACE

THE PRO-35 is a modern mechanism, streamlined and designed for a long life of unequalled performance. The projector is designed to meet or exceed standards for film speed, picture stability, and film protection. Heavy-duty drive components insure reliable operation for extended periods of continuous duty.

THE MAIN FRAME is designed for ruggedness and simplicity. All driving gears are contained within the main frame and submerged in oil. No gears are visible on the drive side of the projector. The mechanism has been designed with roominess for ease of threading, operation, service, and cleaning. The projector, designed for long life, carries a one year warranty on the mechanism, including all film-bearing parts. As a result of the modern design, film-bearing parts can be removed and replaced with great ease.

HIGHEST EFFICIENCY is obtained by the unique conical shutter positioned close to the aperture for maximum light efficiency. Aperture plates are easily replaced for any screen ratio. The lens holder is designed to accept a four-inch lens, and reducers are supplied to accommodate 2-25/32 inch (72mm) lenses. The lens barrel allows complete prefocusing facilities. The lens mount is of heavy, cast iron construction to add weight and bulk for positive anchorage and elimination of any fragility. The lens carrier is mounted to its base with a double "V" lens slide with a microthread lens focus adjustment. A unique picture changeover system is a built-in part of the projector.

THE INTERMITTENT MOVEMENT is of heavy construction with a large cam and star. The starwheel is webbed for additional strength. Unlike commonly used drives, the fractional-horsepower motor drives the intermittent, which in turn drives the projector and soundhead. Framing is accomplished by moving the intermittent sprocket, independent of the shutter, by means of a Delrin spiral coupling. With this method, no other compensation is needed when the picture is framed, and shutter adjustment controls are not necessary.

THE FILM GATE AND TRAP are unique. They are made as an assembly and can be removed as a single unit, thereby eliminating the repeated adjustments required to keep the gate aligned with the trap. Although the film gate is a part of the trap assembly, the gate pressure pads is easily removed for cleaning by means of one screw. The film shoes on the gate pressure pad can be adjusted for tension while film is in motion. The opening and closing mechanism for the film gate incorporates a cam adjustment, allowing adjustment of the gate and trap spacing while the machine is running.

AN OIL DRAIN is easily accessible on the front of the projector main frame to permit draining the projector oil as a service routine. The oil level is indicated by a ring on the clear oil fill tube visible from the off-operator side of the mechanism. A can of Ballantyne Projector Oil is supplied with the projector; use *only* genuine Ballantyne Projector Oil (Part No. 21-98126) in the mechanism.

IN ORDER that all the many features of the Pro-35 may be fully realized, it is recommended that the following instructions be studied carefully to acquaint the operator thoroughly with the mechanism.

IF AT ANY TIME you have a question, or desire aid in securing anticipated results, write directly to STRONG INTERNATIONAL, 4350 McKinley Street, Omaha, Nebraska 68112.

RECEIVING & INSTALLATION

THE PRO-35 PROJECTOR is shipped in a sturdy wooden crate to minimize the possibility of damage in shipment. Remove first the top of the crate (as marked). Identify the operator's side of the projector and remove that side of the crate. The projector is secured to the crate with (2) 3/8-16 screws threaded into the projector base casting, and (2) 3/8-16 bolts with hex nuts. Remove all (4) of these fasteners. Inspect the projector and report any damage to the freight carrier immediately. It is the responsibility of the consignee, not the shipper, to initiate damage claims.

IF INSTALLING a Pro-35 to a VIP Base, the Model VII soundhead is factory-mounted to the base; otherwise, the soundhead must be mounted to a pedestal or projection console. Three holes, on the top surface of the Model VII main frame casting are tapped 3/8-16 and align with (3) clearance holes in the bottom casting of the Pro-35. Mount the projector to the soundhead and secure using the (3) 3/8-16 socket head screws provided. The locations of these clearance holes are held to a close tolerance, and no further projector-to-soundhead alignment is required.

INSTALL THE INTERMITTENT FLYWHEEL and pulley assembly to the intermittent camshaft as illustrated. Observe the assembly sequence of the components. *Do not add oil to the projector until first installing and securing the intermittent flywheel.*

INSERT THE PLASTIC FUNNEL into the oil fill cup on the top of the projector and add Ballantyne Projector Oil until the oil level reaches the ring on the oil fill hose. While adding the oil, periodically rotate the intermittent flywheel to turn the mechanism and eliminate air locks. **DO NOT OVERFILL.**

AN ALTERNATE METHOD of adding the projector oil is to remove the breather tube from the top of the projector and prop open the oil fill cup. Insert the funnel into the breather tube opening and add the oil, while periodically rotating the intermittent flywheel as above. After filling, replace the breather tube and reset the lid of the oil cup.

INSTALL THE DRIVE BELT between the motor pulley and the intermittent flywheel pulley. The standard 115 V.AC induction motor is mounted to the base casting of the projector in a pivoting support cradle. Apply belt tension by tightening the front-mounted socket head screw connected to the motor cradle until belt tension is adequate.

THE SYNCHRONOUS DRIVE MOTOR mounts to the top casting of the projector. Run the drive belt from the motor pulley to the intermittent flywheel pulley and apply belt tension by tightening the idler roller mounted to the inside of the top casting against the drive belt.

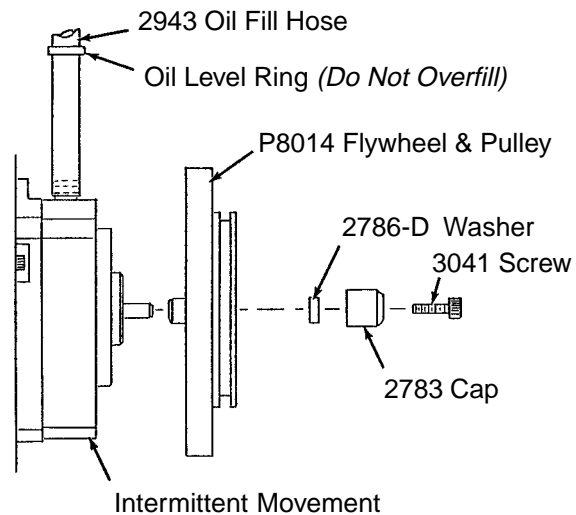

INSTALLATION (continued)

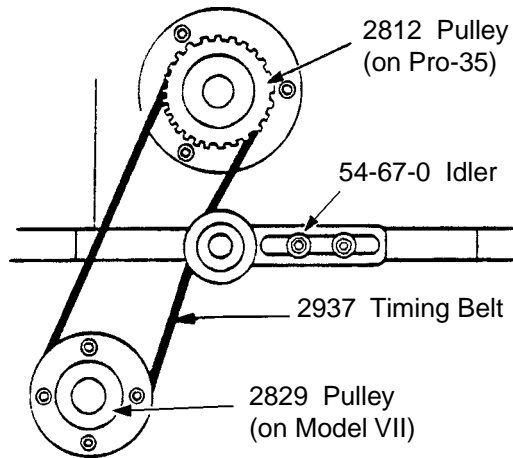

INSTALL THE SOUNDHEAD DRIVE BELT as illustrated. Slide the 54-67-0 idler pulley assembly against the belt to set the belt tension. Securely tighten the (2) socket head screws when belt tension is correct.

DO NOT OVERTIGHTEN either of the drive belts. Timing belt tension should be sufficient to allow the belt cogs to firmly engage the pulley teeth. Tightening beyond this point shortens belt life and may damage shafts and bearings.

CONNECT THE AC INPUT to the motor terminals. See the Data Plate on the motor to determine the correct voltage requirements. The motor line must be externally switched; no motor switch is provided with the Pro-35. Apply a second (unswitched) AC line to the Framing Lamp Power Supply/ Changeover Power Supply.

THREADING

THREADING THE PROJECTOR correctly is one of the operator's most important duties. Proper attention to detail in this operation pays off in improved performances and long print life.

IT IS RECOMMENDED to clean all film-bearing surfaces prior to each threading operation. The roomy interior of the Pro-35 simplifies this procedure. Open the film gate using the Gate Release Lever. Loosen, but do not remove, the Pressure Pad Retaining Screw, and dismount the gate pressure pad assembly. Wipe the gate pads and the trap shoes using a clean, dry cloth. Re-install the gate pressure pad assembly.

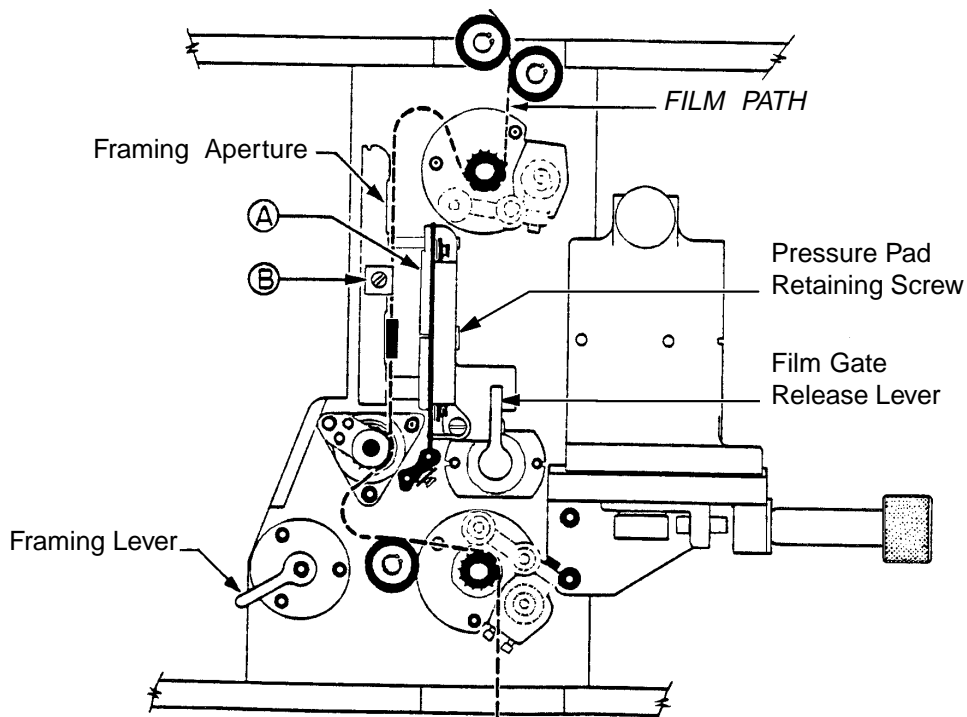

THREAD THE PROJECTOR following the film path illustrated above. Check for correct frame position at the Framing Aperture before closing the gate and engaging the intermittent sprocket shoes. After closing the gate, make certain that the gate pressure pad (Item A) is inside the lateral stabilizer plate (Item B). The lateral stabilizer should be resting on the outboard edge of the film.

INCH THE PROJECTOR by hand and carefully inspect the film path before turning on the projector motor. Run fingers over each sprocket to insure that the sprocket teeth are centered in the film perforations, and the film is centered between the pad roller flanges. Check again the position of the film in the framing aperture. A correct frame image in the framing aperture insures correct frame positioning on the picture aperture.

MISFRAMES can be corrected by rotating the Framing Lever up or down. This adjustment may be made when the projector is running.

PROJECTION LENS INSTALLATION

1. Adjust Focus Knob (E) to the center of its travel. The degree of torque required to operate the focus adjustment is controlled by tightening or loosening socket head screw (H). NOTE: too loose a setting may allow focus drift.
2. Insert Lens Reducer (A) into Lens Barrel (C) with Pin (B) seated in notch as shown. Secure the Lens Reducer by tightening Knob (D).

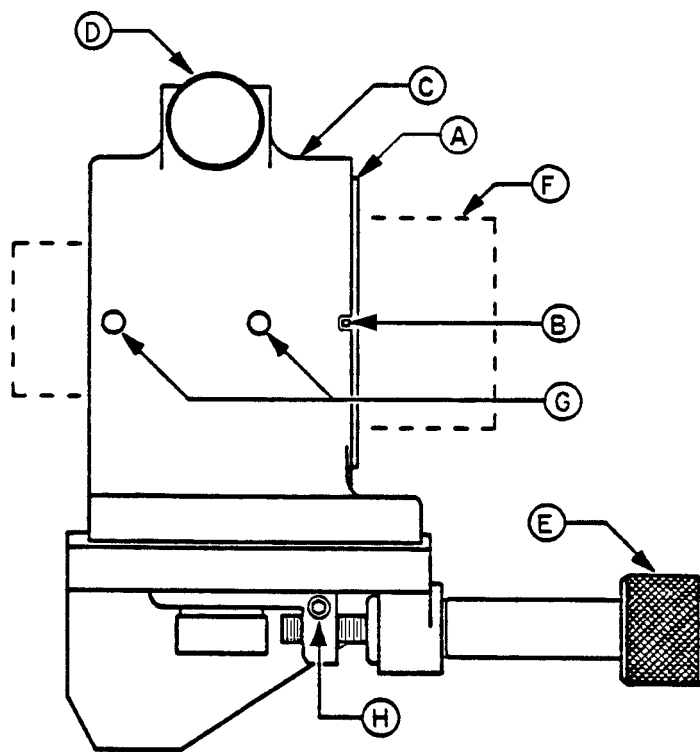

3. Install Projection Lens (F) into Lens Reducer and adjust for correct focus. When installing an anamorphic lens and adapter, observe proper horizontal anamorphic correction in addition to focus.
4. When the picture is correctly focused and positioned, lock the lens to the lens reducer by tightening the (2) nylon set screws through access holes (G).
5. With the lens mated to the reducer in this manner, little or no adjustment of focus control knob (E) will be required when changing projection format, i.e. CinemaScope to wide-screen (anamorphic to flat).

MAINTENANCE

CLEANLINESS is the most important element in maintaining the Pro-35 projector. It is advisable to thoroughly clean all film-bearing surfaces in the gate and trap, each sprocket, and all pad rollers prior to every performance.

USE A CLEAN, DRY CLOTH to clean the inner surfaces of the gate pressure pads, trap shoes, and studio guides. A toothbrush with soft to medium bristles is an excellent tool for cleaning sprocket teeth and pad rollers. Pad rollers must operate freely at all times; if unable to rotate, they will rapidly develop flat spots and require replacement.

THE LATERAL STABILIZER in the film trap must be removed and cleaned periodically. Remove the shoulder screw (A), coil spring (B), and stabilizer plate (C) as shown. Make certain area (D) is free of dirt and film debris. After replacing, make certain stabilizer plate (C) acts freely against spring (B).

THIS STABILIZER ASSEMBLY must be removed to gain access to the trap mounting screw in area (D). This captive, slot-headed screw must be loosened to permit dismounting the trap for cleaning or service.

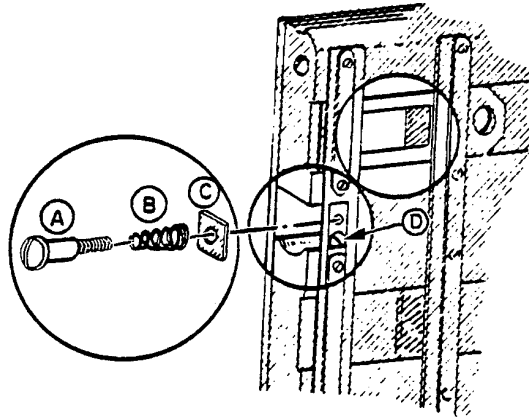

CHANGE THE OIL at least once every year of normal service. Remove the hex head screw from the end of the drain pipe and allow the old oil to drain. Inspect the O-ring below the head of the drain screw and replace if cracked or worn. Replace the drain screw and fill the projector with Ballantyne Projector Oil (Part No. 21-98126). Fill to the ring only; *do not overfill*.

CHECK THE DRIVE BELTS and adjust for proper tension if required. Inspect the belts and replace if cracked or worn.

PERIODICALLY INSPECT the entire mechanism and make certain all fasteners are securely tightened. Vibration from normal operation may cause fasteners to loosen after prolonged periods.

OPERATOR ADJUSTMENTS

THE FINE ADJUSTMENTS necessary to project the steadiest picture are made at the factory by skilled technicians prior to shipping. In time, these adjustments will change, and require the attention of the operator. Because of the advanced design of the Pro-35, these periodic adjustments can be made in a short time with a minimum of effort.

PAD ROLLER ASSEMBLIES

1. Place the pad roller assembly in the CLOSED position. Loosen set screw (A).
2. Loosen set screw (B) on the rear eccentric roller (C). Rotate pad roller (C) *away* from film sprocket (D).
3. Wrap TWO thicknesses of film around film sprocket (D). This spacing will permit the safe passage of film splices.
4. Position pad roller (E) so that it just touches the two thicknesses of film on film sprocket (D).
5. Tighten set screw (A).
6. Rotate the eccentric pad roller (C) so that it too just touches the film on sprocket (D).
7. Tighten set screw (C).

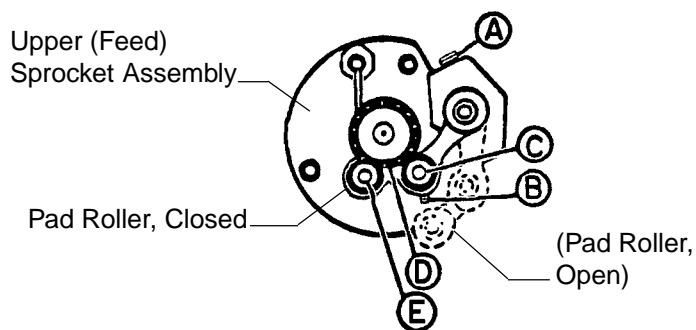
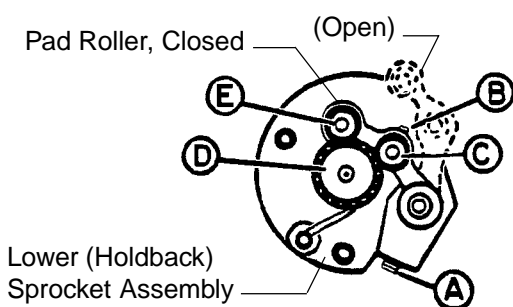

FILM GATE ASSEMBLY

Coarse adjustment of gate pressure pad tension is made at point (D). Adjust Eccentric Screw (D) while the machine is running. At the minimum setting, film transport noise will be excessive. Adjust the gate toward the trap until transport noise minimizes. Observe the projected picture on the screen.

Fine tension adjustments are made at points (A), (B), and (C). Observe the screen while making fine adjustments; maintain the lightest possible gate tension without affecting the quality of the picture.

The large (1/4-20) set screws at point (E) permit adjusting the vertical position of the film gate. Keep the gate pressure pads parallel with the trap studio guides. The small set screws at point (E) lock the settings of the 1/4-20 set screws.

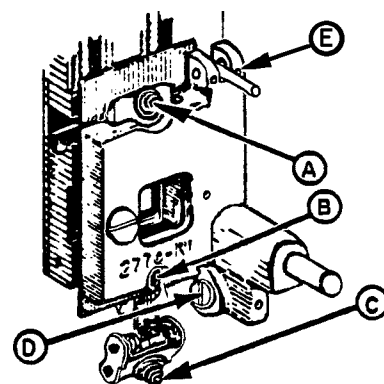

SHUTTER TIMING

A mis-timed shutter will cause noticeable flicker or ghosting of the projected picture. "Travel Ghost" is the term commonly applied to vertical streaking of lighter areas against a darker area, and is particularly apparent during opening or closing titles and credits.

To gain access to the shutter, remove the framing lever and rear quarter panel as shown:

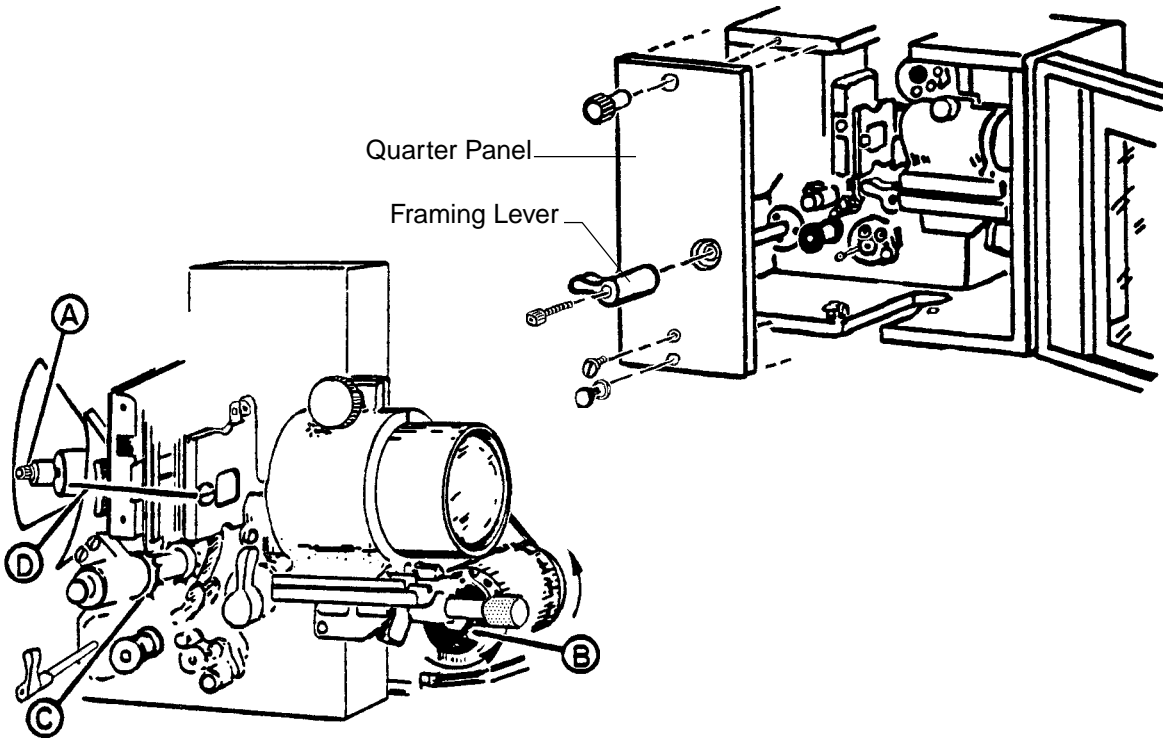

1. Loosen screw (A) to permit the shutter blade to rotate freely on its shaft.
2. Turn inching knob (B) to cycle the intermittent movement. With the movement at rest, select one intermittent sprocket tooth (C) and mark its position with a stationary object, like the tip of a screwdriver blade.
3. With the sprocket tooth position marked, turn inching knob (B) *slowly* in a counterclockwise direction until the intermittent sprocket (C) advances TWO teeth.
4. Hold the inching knob (B) to prevent the mechanism from moving, and rotate the loosened shutter blade until one of the blades is fully blocking the picture aperture. The center of the blade should align with the aperture centerline (D).
5. Firmly tighten screw (A). Repeat Step 3. After a (2) tooth advance, the center of the shutter blade should be at the aperture centerline (D) as shown.
6. Replace the quarter panel and the framing lever.

FRAMING TENSION

The amount of tension required to operate the framing lever (I) is adjustable, although a degree of tension is required to prevent the film from “creeping” out of frame. The adjustment screw (B), held in position by locknut (A), applies or relieves tension on the nylon tension plug (C). In turn, the tension plug (C) applies or relieves pressure against the vertical framing shaft (D), regulating the coupler assembly (E). Torque applied to framing lever (I) is transmitted through shaft (H) and gear (G). Rotation of the vertical framing shaft (D) moves the coupler assembly on a horizontal plane, changing the frame position of the intermittent sprocket (F).

Framing tension is adjusted as follows:

1. Remove the framing lever and the rear quarter panel (see “Shutter Timing”).
2. Remount the framing lever (I).
3. Loosen locknut (A) and tighten or loosen adjustment screw (B) as required. The framing lever (I) should move with relative ease, however, inadequate pressure on tension plug (C) will allow film to “creep” out of frame.
4. Re-tighten locknut (A); remove framing lever (I).
5. Replace the rear quarter panel and the framing lever.

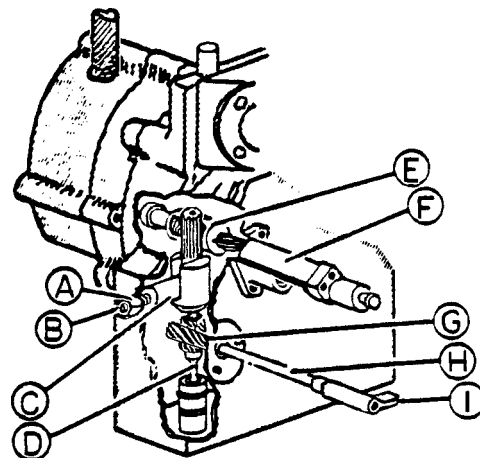

INTERMITTENT SPROCKET ALIGNMENT

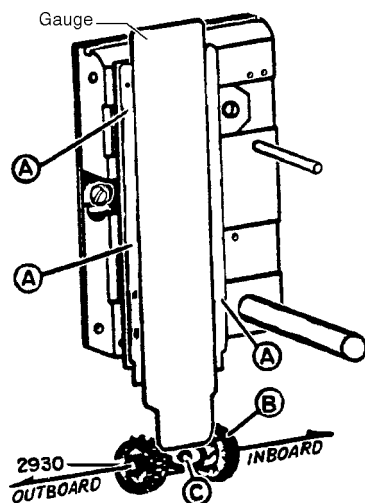

The intermittent sprocket is secured to the outboard intermittent sprocket shaft in a manner which permits a slight degree of horizontal adjustment of the sprocket. This adjustment is facilitated by use of a Studio Guide Gauge available from Strong International Dealers. Gauge 3567-F (as shown) is designed for Pro-35 projectors in current production; for older models (without the lateral stabilizer plate), order Gauge 3568-F.

Place the gauge between the studio guides (A) as shown. Loosen, but do not remove, screw (C). Slide the sprocket on its shaft until it is centered on the narrow portion of the gauge. Securely re-tighten screw (C).

NOTE:

3567-F = 1.377 in. wide

3568-F = 1.375 in. wide

INTERMITTENT MOVEMENT

The intermittent movement is the mechanical heart of the Pro-35. Components are machined to near-zero tolerances, and assembly, run-in, and testing are performed by trained personnel using special tools and fixtures. For this reason, operator adjustments performed in the field are very limited.

Factory Rebuilt intermittent movements are available under a Repair/Exchange program. Contact an authorized Strong International Dealer for details; do not return Pro-35 intermittent movements to the factory without first acquiring a Return Authorization Number.

The outboard bearing assembly is accessible at the end of the intermittent sprocket shaft on the threading side of the projector. The purpose of the outboard bearing adjustment bolt (A) is to keep the ends of the intermittent sprocket shaft (B) in contact with starwheel shaft (C), eliminating any end play at the intermittent sprocket. Adjustment bolt (A) is the *only* field-adjustable element.

Adjust bolt (A) *fingertight only*. Correctly set, bolt (A) will keep shaft (B) in contact with shaft (C) without end play or binding. **DO NOT USE PLIERS OR ANY OTHER FASTENING TOOL.**

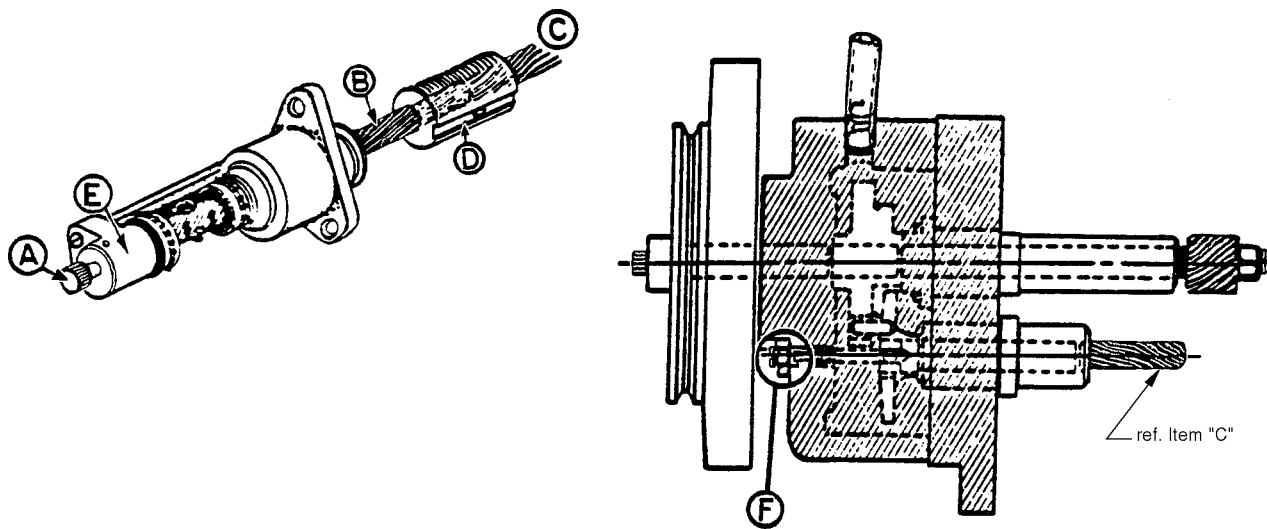

NOTE: Possibly because of its accessibility, operators sometimes overtighten bolt (A). This action causes **DAMAGE** in the bearing area (E) and applies stress on the starwheel bushing area (C) and coupling (D). Excessive tension for prolonged periods may damage the **ENTIRE MOVEMENT**.

On the drive (off-operator) side of the mechanism, beneath the intermittent flywheel, the cam stop pin and locknut assembly (F) is accessible. This assembly is considered field-adjustable only when the adjustment is performed by **QUALIFIED PERSONNEL**. Consult the factory before attempting to change the setting of the cam stop pin.

INTERMITTENT COUPLING

The intermittent coupling is not an integral part of the intermittent movement, and can be readily removed for repair, service, or replacement.

1. Drain the oil from the projector.
2. Remove the framing lever and the rear quarter panel (see “Shutter Timing”).
3. Replace the framing lever.
4. Remove the film gate and the lateral stabilizer plate (from the trap).
5. Loosen the trap mounting screw (exposed by removing the lateral stabilizer) and dismount the trap. The trap is located on (2) dowel pins, and requires reasonable force to unseat. DO NOT strike the intermittent sprocket teeth when removing the film trap.
6. Loosen the locknut and framing tension screw on the back of the main frame by 1/4 turn.
7. Remove the (3) socket head screws securing the intermittent sprocket assembly to the main frame. Rotate the framing lever while drawing the sprocket assembly out of the mechanism.

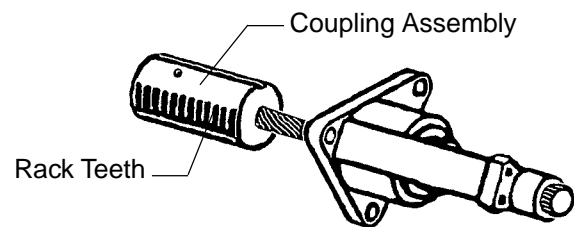
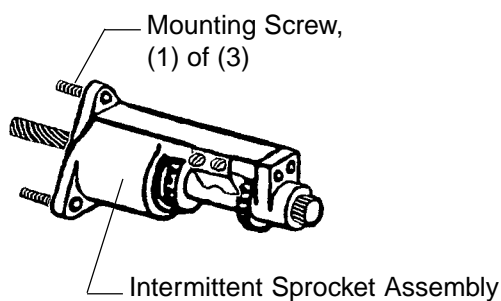

8. The coupler assembly may come out with the intermittent sprocket assembly. If not, rotate the framing lever to move the coupling forward, and remove by hand.
9. Take careful notice of the end of the coupler assembly and replace it onto the shaft exactly as it came off. Repeat this several times to observe the “feel” of the fit.
10. Replace the coupling on the sprocket shaft and align the rack teeth vertically as illustrated. Slide the coupling and the sprocket shaft assembly into the main frame with the rack teeth facing the shutter. Rotate the sprocket back and forth to align the coupling splines to the starwheel shaft splines. When correctly installed, it will fit on the shaft with the same “feel” as before.
11. Replace all parts and hardware removed prior.
12. Tighten the framing tension adjustment screw to apply correct pressure on the framing assembly. Tighten the locknut.
13. Secure the drain plug screw and replace the projector oil.

Pro-35 Parts Catalog

Ballantyne replacement parts are available through any authorized Strong International Dealer.

Please order by *Part Number* and *Description*.

All returned goods must display a **Return Authorization** Number issued to an authorized Strong International Dealer.

STRONG INTERNATIONAL

a division of Ballantyne of Omaha, Inc,
4350 McKinley Street
Omaha, Nebraska 68112 U.S.A.
Tel 402/453-4444 • Fax 402/453-7238

MAIN FRAME

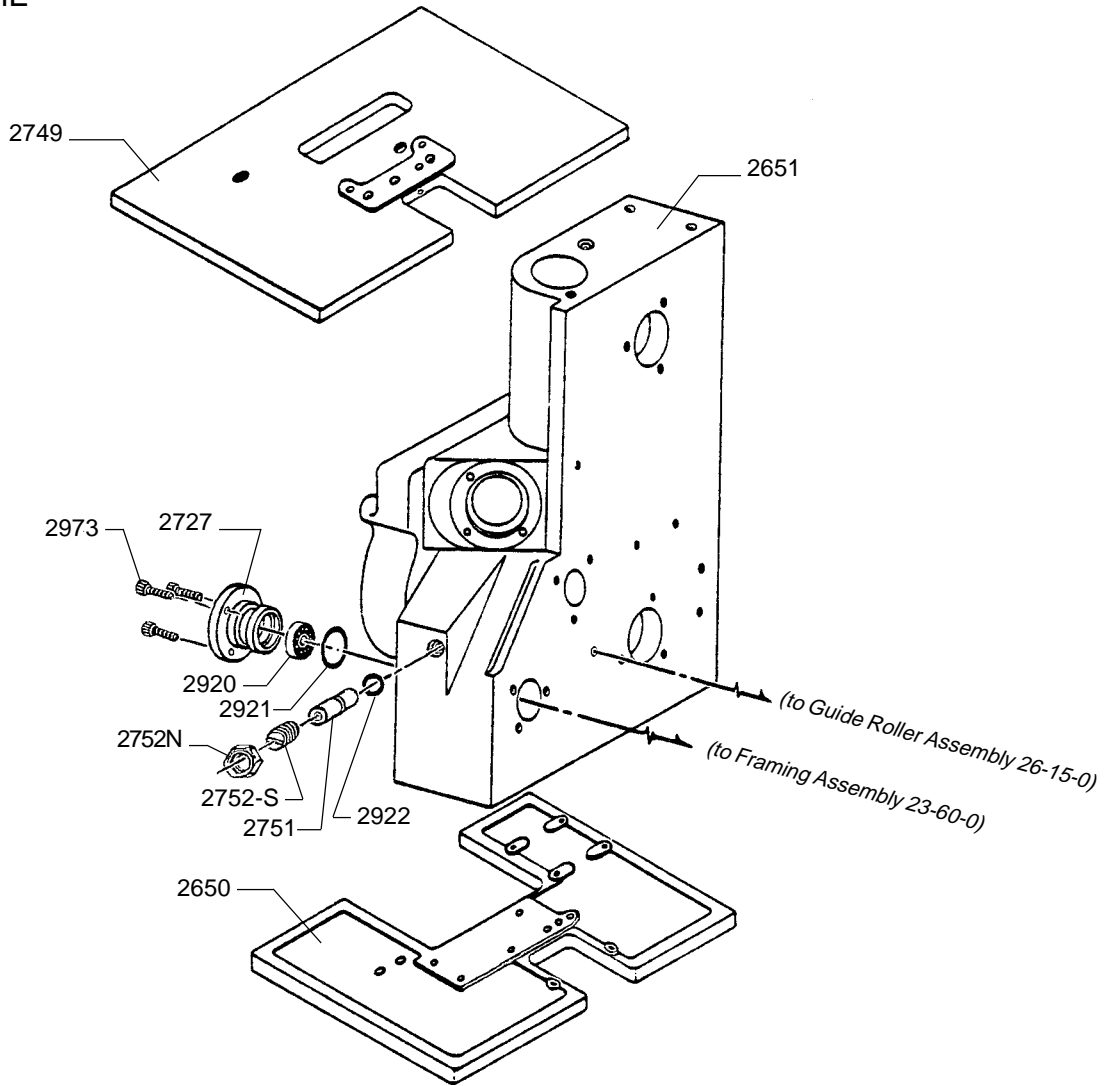

<u>Part No.</u>	<u>Description</u>
2650	Base Casting
2651	Main Frame
2727	Framing Shaft Cap, Rear
2749	Top Plate Casting
2751	Tension Plug, Nylon
2752-S	Tension Adjusting Screw
2752N	Lock Nut
2920	Ball Bearing
2921	O-Ring
2922	O-Ring
2973	Screw, 10-32 x 5/8" Socket Head

VERTICAL SHAFT ASSEMBLY

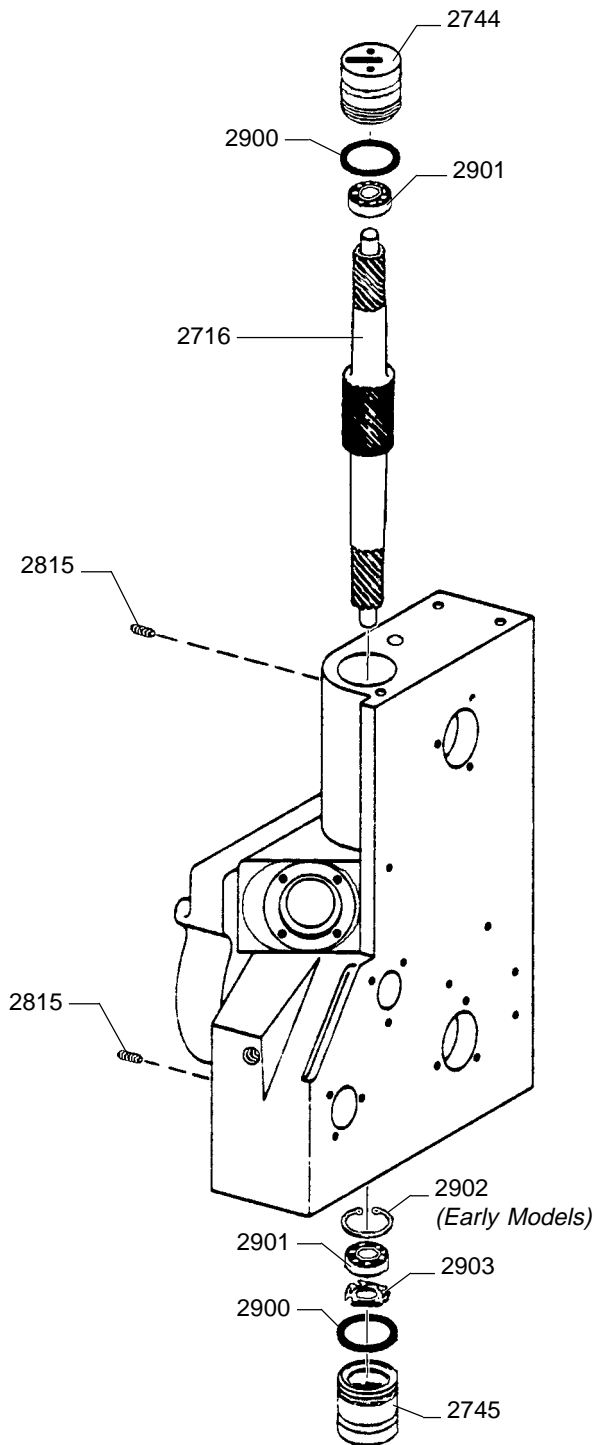

<u>Part No.</u>	<u>Description</u>
2651	Main Frame
2716	Vertical Shaft
2744	Top Cap
2745	Bottom Cap
2815	Cap Locking Screw (2 req'd.)
2900	O-Ring (2 req'd.)
2901	Ball Bearing (2 req'd.)
2902	Snap Ring (Early Models)
	<i>(2902 not used in Current Production)</i>
2903	Spring Washer

HORIZONTAL SHAFT ASSEMBLIES

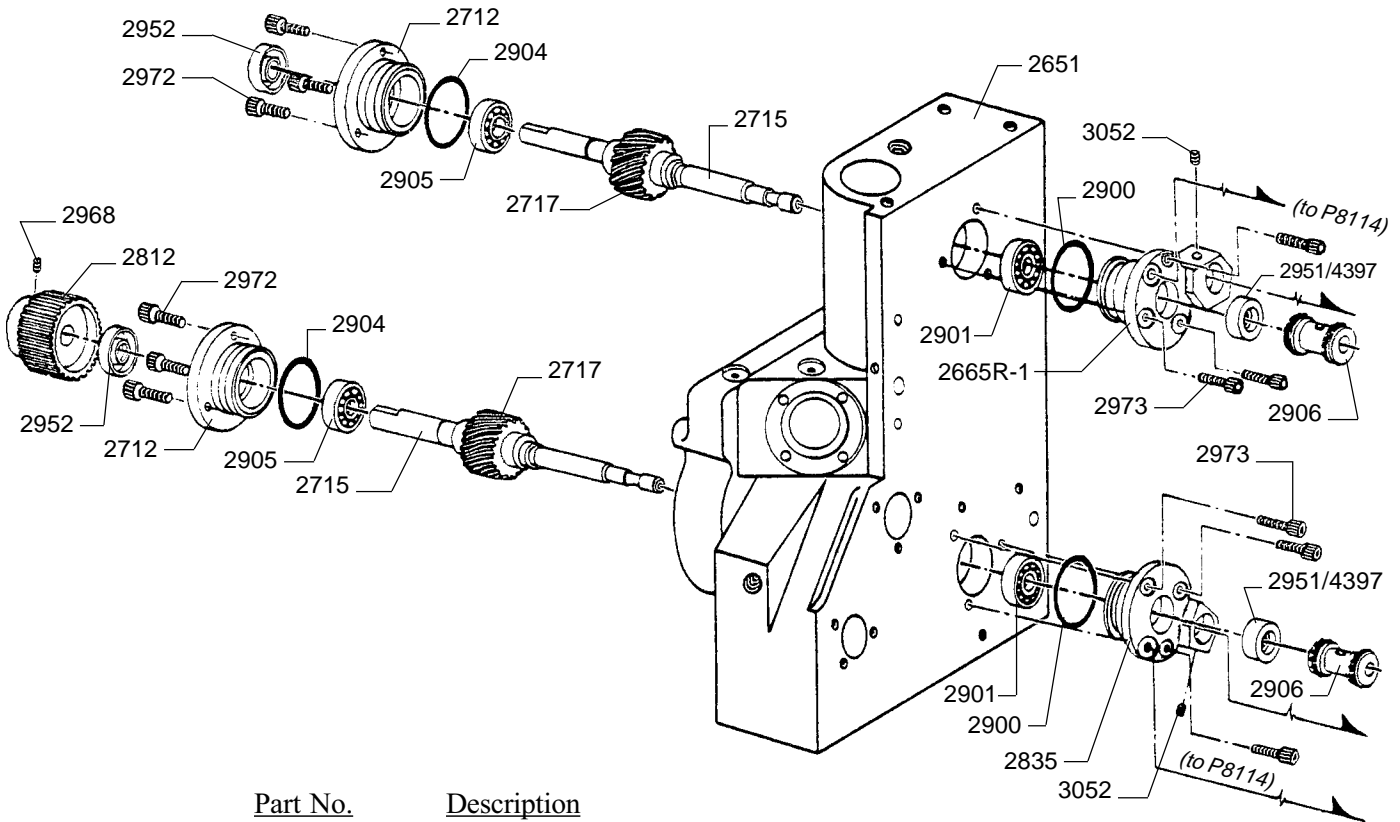

Part No.	Description
2651	Main Frame
2665R-1	Horizontal Shaft & Pad Roller Housing, Upper
2712	Horizontal Shaft Cap, Rear (2 req'd.)
2715	Horizontal Sprocket Shaft (2 req'd.)
2717	Helical Gear, Horizontal Shaft (2 req'd.)
2812	Drive Sprocket, Model VII Soundhead
2835	Horizontal Shaft & Pad Roller Housing, Lower
2900	O-Ring (2 req'd.)
2901	Ball Bearing (2 req'd.)
2904	O-Ring (2 req'd.)
2905	Ball Bearing (2 req'd.)
2906	Film Sprocket, 35mm VKF® (41GL37B)
2951	Oil Seal (before Serial Number 2448)
2952	Oil Seal
2968	Set Screw, 1/4-20 x 1/2"
2972	Screw, 10-32 x 1/2" Socket Head
2973	Screw, 10-32 x 5/8" Socket Head
3052	Set Screw, 1/4-20 x 3/8"
4397	Oil Seal (after Serial Number 2448)
P8114	Film Stripper Assembly (not shown)

SHUTTER SHAFT ASSEMBLY

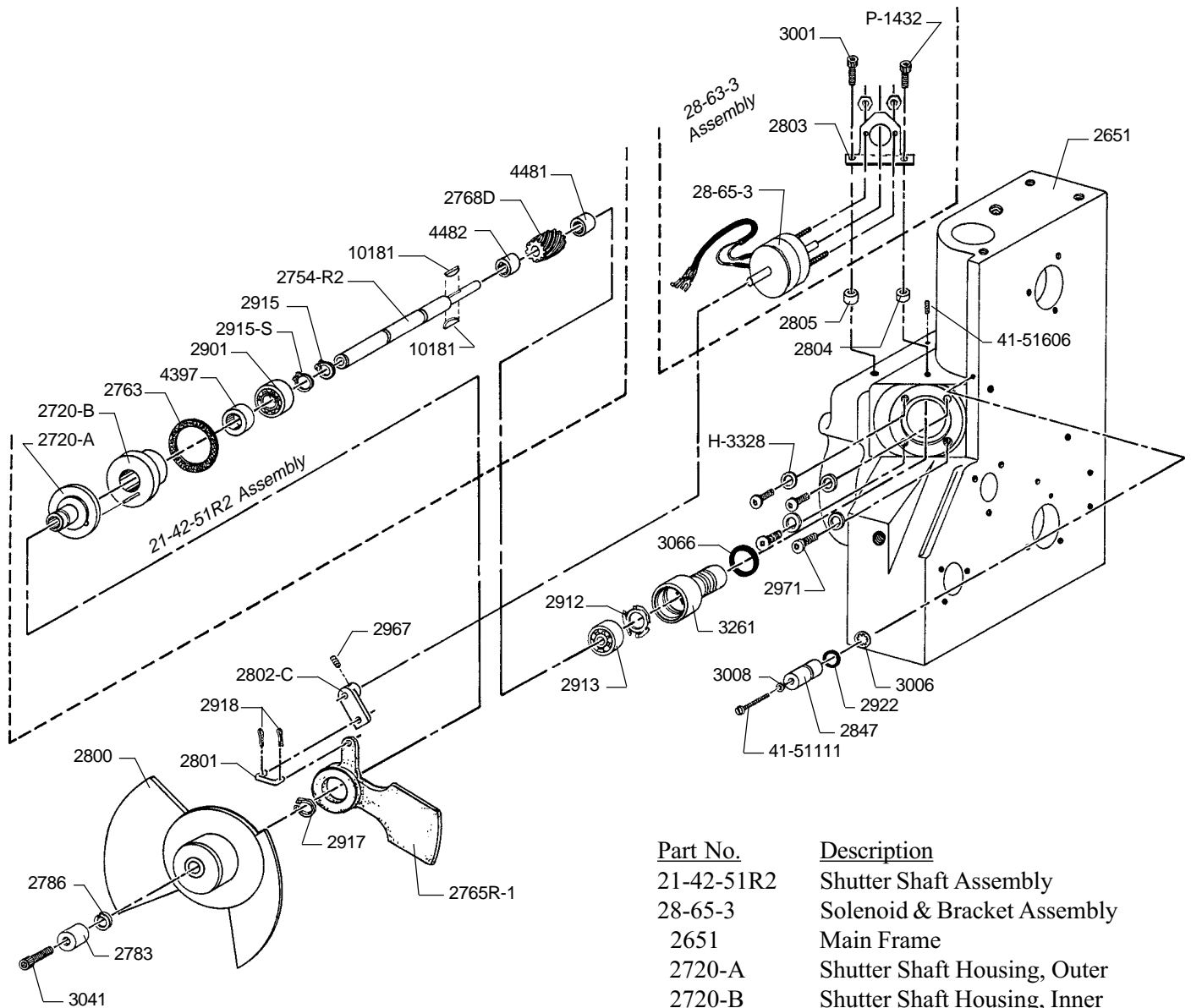

<u>Part No.</u>	<u>Description</u>
21-42-51R2	Shutter Shaft Assembly
28-65-3	Solenoid & Bracket Assembly
2651	Main Frame
2720-A	Shutter Shaft Housing, Outer
2720-B	Shutter Shaft Housing, Inner
2754-R 2	Shutter Shaft
2763	Gasket
2765R-1	Douser Blade
2768D	Gear, Shutter Shaft
2783	Shaft Cap
2786	Cap Washer, Brass
2800	Shutter Blade
2801	Connecting Link

SHUTTER SHAFT ASSEMBLY
Parts List (continued)

<u>Part No.</u>	<u>Description</u>
2802-C	Linkage Arm
2803	Solenoid Bracket
2804	Spacer, 1/4"
2805	Spacer, 7/16"
2847	Stop Pin, Teflon
2901	Ball Bearing
2912	Spring Washer
2913	Ball Bearing
2915	Snap Ring, Inner
2915-S	Snap Ring, Outer
2917	Snap Ring
2918	Cotter Pin
2922	O-Ring
2967	Set Screw, 8-32 x 1/8"
2971	Screw, 10-32 x 1/2" Button Head
3001	Screw, 8-32 x 7/8" Socket Head
3006	Lockwasher, 3/8"
3008	Lockwasher, #10
3041	Screw, 10-32 x 3/8" Socket Head
3066	O-Ring
3261	Shutter Shaft Eccentric Bushing
4397	Oil Seal
4481	Outer Spacer
4482	Inner Spacer
10181	Woodruff Key, #204
41-51111	Screw, 10-32 x 1-1/4" Fillister Head
41-51606	Set Screw, 1/4-20 x 1/2" Stainless Steel
H-3328	Flatwasher, #10
P-1432	Screw, 8-32 x 5/8" Socket Head

HORIZONTAL FRAMING ASSEMBLY

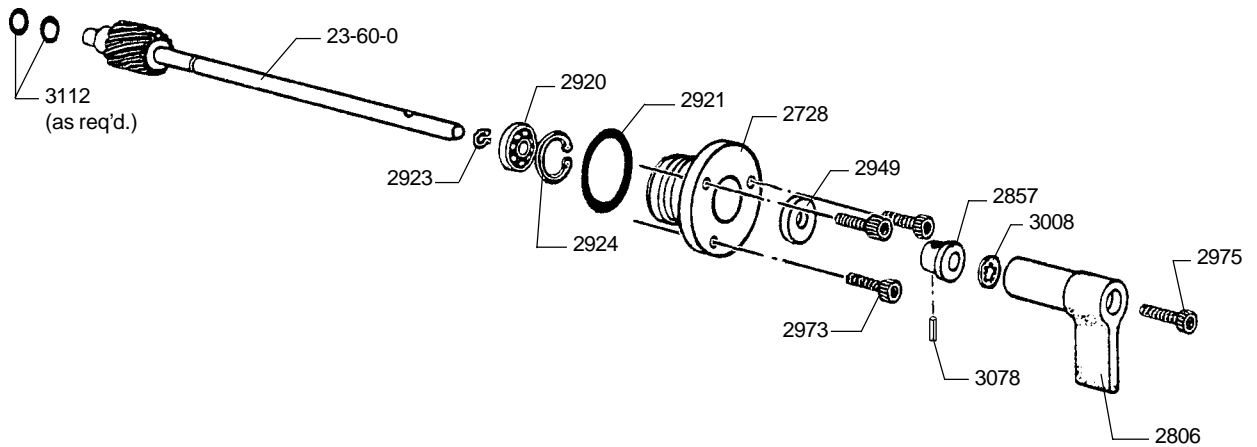

<u>Part No.</u>	<u>Description</u>
21-04-46	Horizontal Framing Assembly (complete as shown)
23-60-0	Framing Shaft & Gear Assembly
2728	Cap, Framing Shaft (Front)
2806	Framing Lever
2857	Framing Lever Flange
2920	Ball Bearing
2921	O-Ring
2923	Retaining Ring
2924	Snap Ring
2949	Oil Seal
2973	Screw, 10-32 x 5/8" Socket Head
2975	Screw, 10-30 x 1" Socket Head
3008	Lockwasher, #10
3078	Roll Pin, 1/8 x 9/16"
3112	Fibre Washer (quantity as req'd.)

VERTICAL FRAMING ASSEMBLY

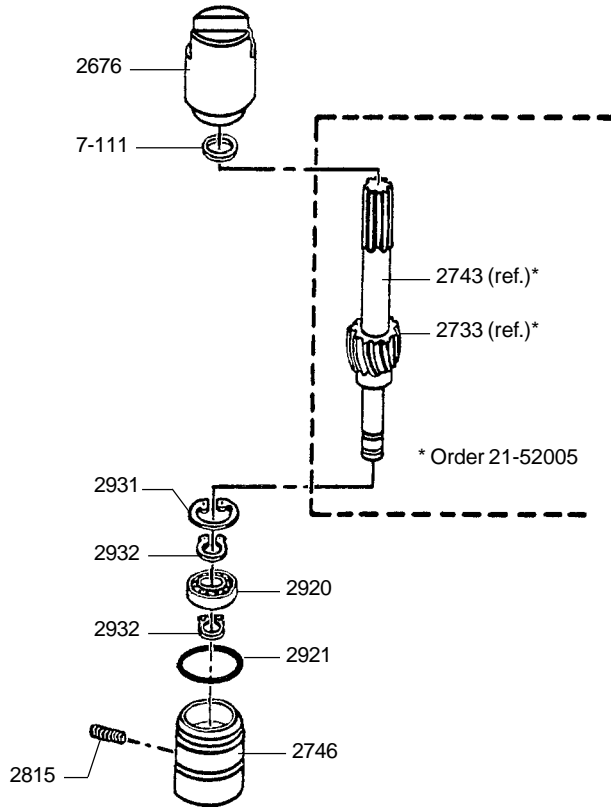

<u>Part No.</u>	<u>Description</u>
21-41-04	Vertical Framing Assembly (complete as shown)
2676	Framing Shaft Bushing
2733	Gear (Order 21-52005)
2743	Shaft (Order 21-52005)
2746	Bottom Cap, Framing Shaft
2815	Cap Lock Screw
2920	Ball Bearing
2921	O-Ring
2931	Snap Ring
2932	Snap Ring
7-111	Fibre Washer

LENS MOUNT ASSEMBLY

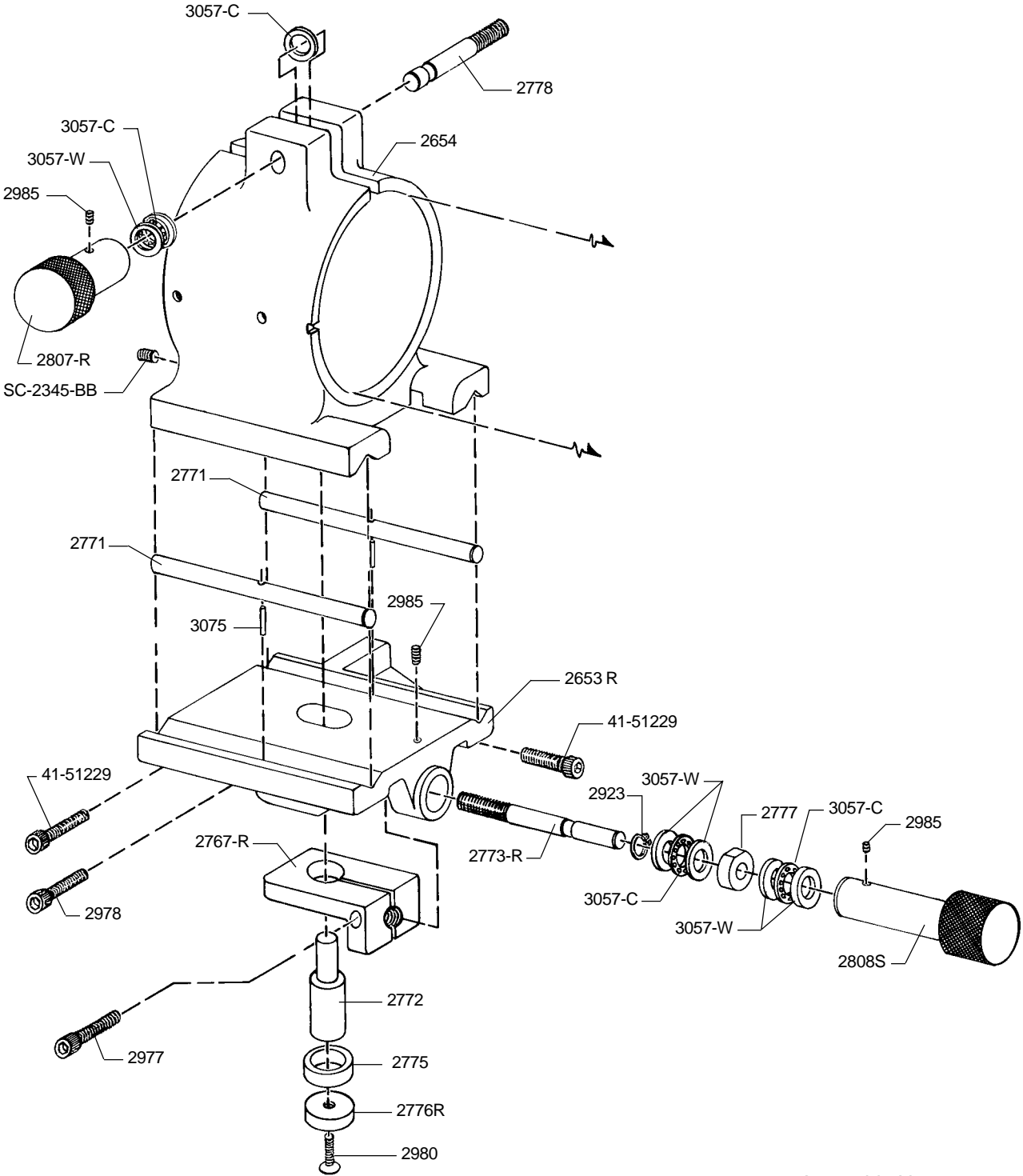

Assembly No. 24-42-09

PARTS LIST, Lens Mount Assembly

<u>Part No.</u>	<u>Description</u>	<u>Part No.</u>	<u>Description</u>
2653 R	Lens Barrel Mount	2808S	Lens Focus Knob
2654	Lens Barrel	2923	Snap Ring
2767-R	Focus Bracket	2977	Screw, 1/4-20 x 1" Socket Head
2771	Lens Barrel Slide Rod	2985	Set Screw, 1/4-20 x 1/4"
2772	Lens Mounting Stud	2978	Screw, 5/16-18 x 3/4" Soc. Head
2773-R	Lens Focus Screw	2980	Screw, 1/4-20 x 1/2" Flat Head
2775	Rubber Bushing	3057-C	Thrust Bearing
2776 R	Stud Washer	3057-W	Thrust Washer
2777	Bearing Spacer	3075	Roll Pin, 1/8 x 3/4"
2778	Lens Clamping Shaft	SC-2345-BB	Set Screw, 5/16-18 x 1/2"
2807-R	Lens Clamping Knob	41-51229	Screw, 5-16-18 x 1" Soc. Head

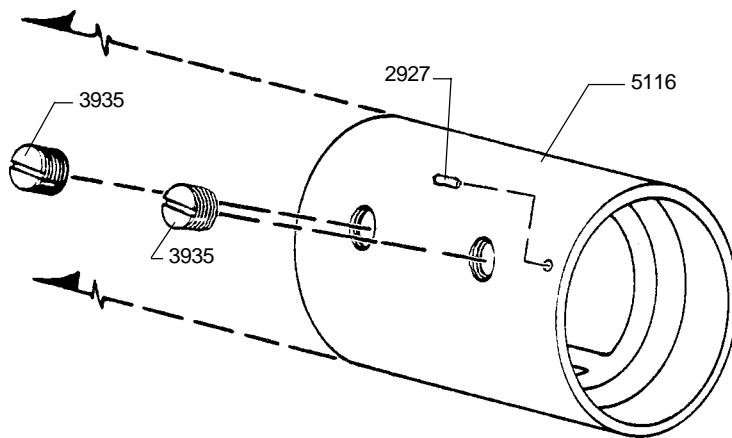

LENS REDUCER
 Assembly No. 28-13-5

<u>Part No.</u>	<u>Description</u>
2927	Roll Pin, 1/8 x 1/2"
3935	Lens Retaining Screw, Nylon
5116	Lens Reducer Casting

FILM TRAP ASSEMBLY

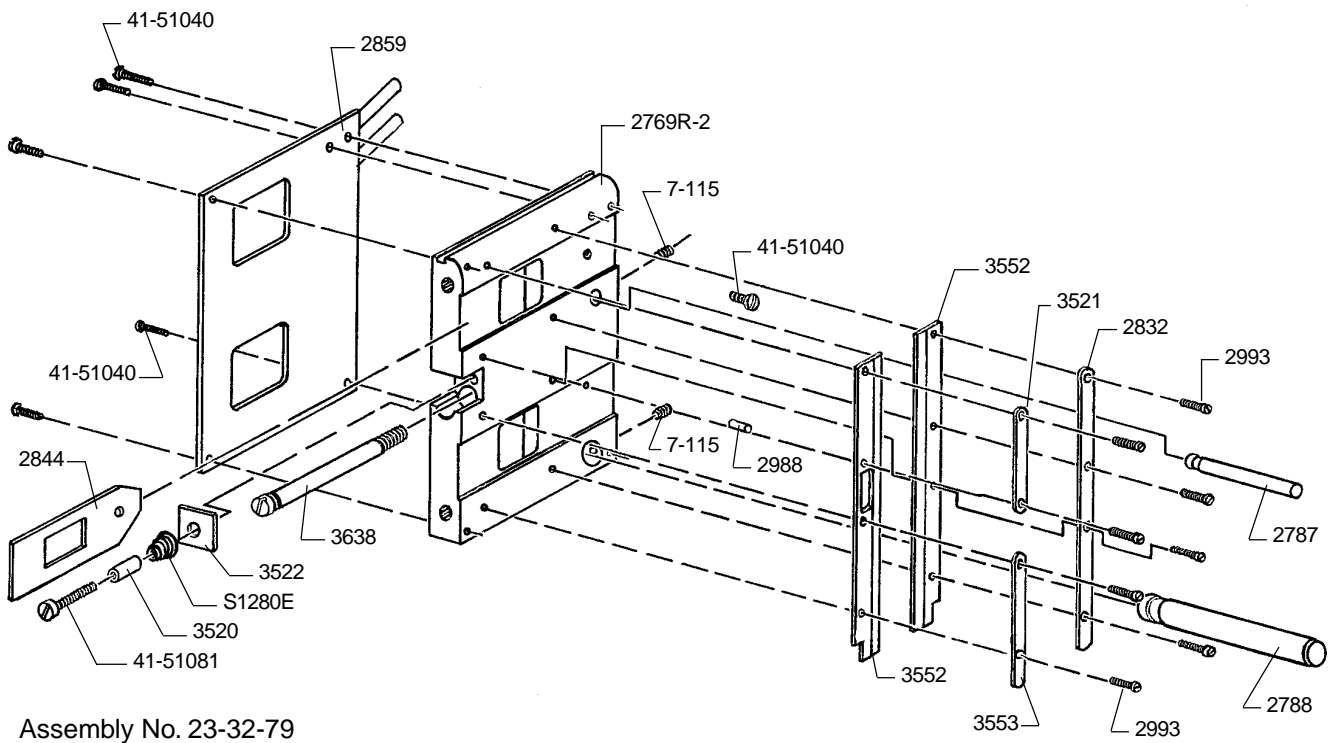

Assembly No. 23-32-79

<u>Part No.</u>	<u>Description</u>
S1280E	Coil Spring
2769R-2	Film Trap Plate
2787	Upper Slide Shaft
2788	Lower Slide Shaft
2832	Studio Guide, Inboard
2844	Framing Aperture
2859	Water Jacket, Film Trap
2988	Dowel Pin. 1/8 x 1/2"
2993	Screw, 3-48 x 3/8" Truss Head
3388	Aperture Plate, Flat (not shown)
3389	Aperture Plate, Scope (not shown)
3520	Spacer
3521	Upper Studio Guide, Outboard
3522	Lateral Guide Plate
3552	Trap Shoes (set of two)
3553	Lower Studio Guide, Outboard
3638	Trap Mounting Screw
7-115	Set Screw, 10-32 x 3/16"
41-51040	Screw, 6-32 x 3/8" Truss Head

FILM GATE ASSEMBLY

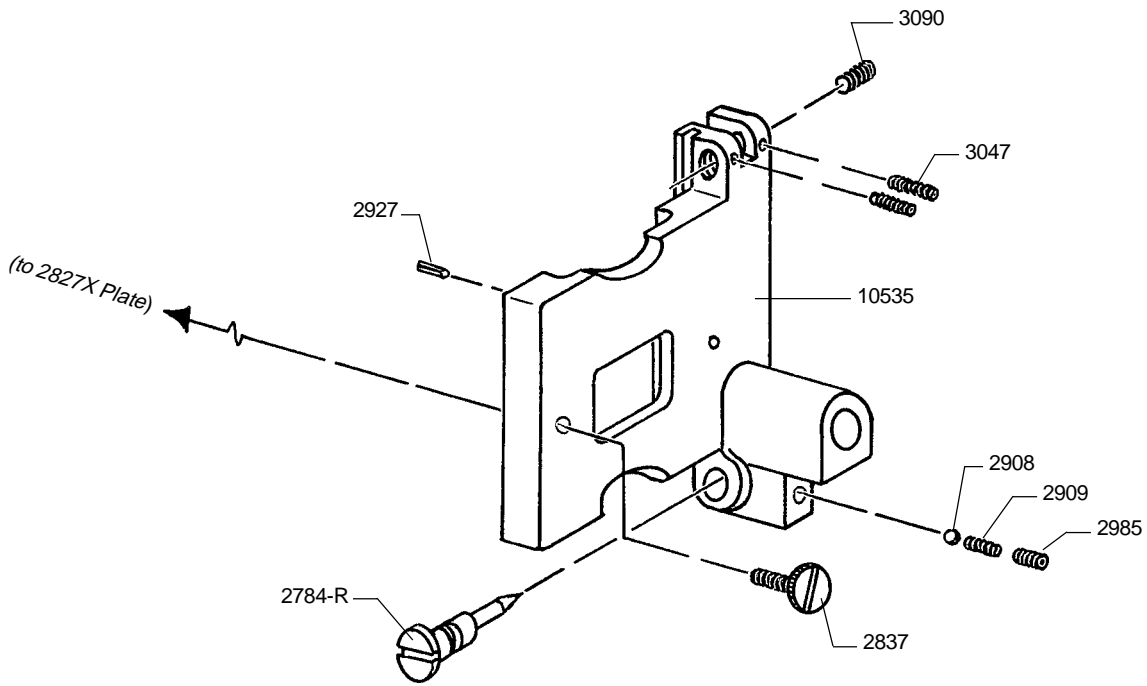

Assembly No. 29-88-4

<u>Part No.</u>	<u>Description</u>
10535	Gate Support Casting
2784-R	Eccentric Screw
2837	Pressure Pad Retaining Screw
2908	Steel Ball, 3/16"
2909	Compression Spring
2927	Roll Pin, 1/8 x 1/2"
2985	Set Screw, 1/4-20 x 1/4"
3047	Set Screw, 10-32 x 5/16" Nylon
3090	Set Screw, 1/4-20 x 3/4" Brass

FILM GATE PRESSURE PAD ASSEMBLY

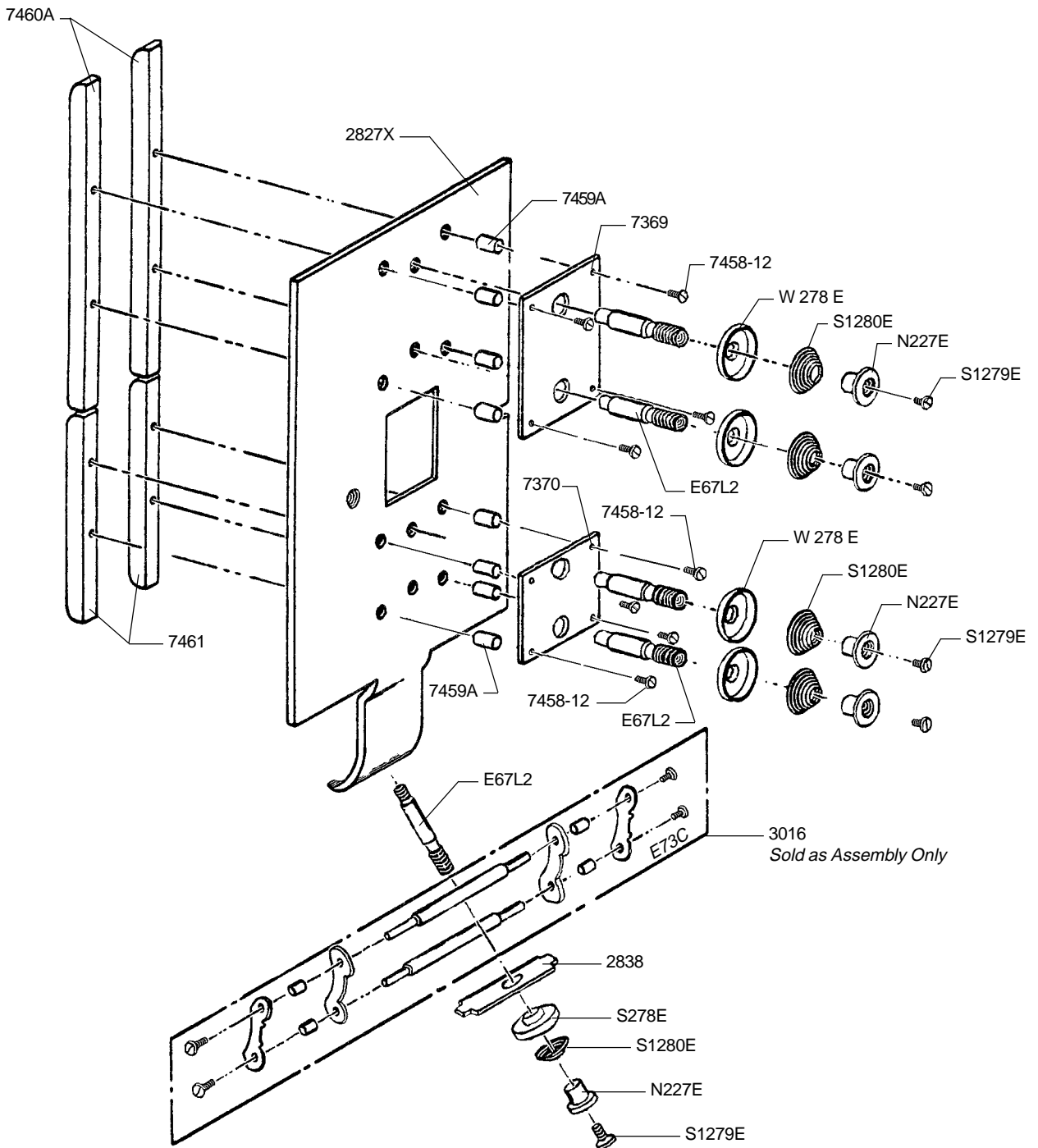

Assembly No. 7458

PARTS LIST, Pressure Pad Assembly 7458

<u>Part No.</u>	<u>Description</u>
2827X	Pressure Pad Plate
2836	Shoe Tension Plate
3016	Intermittent Sprocket Shoe Assembly
7369	Back Plate, Upper
7370	Back Plate, Lower
7458-12	Screw
7459A	Spacer
7460A	Pressure Pad, Upper
7461	Pressure Pad, Lower
E67L2	Stud
N227E	Tension Adjusting Nut
S1280E	Coil Spring
S1279E	Screw
W 278 E	Spring Cup Washer

GATE DETENT MOUNTING ASSEMBLY

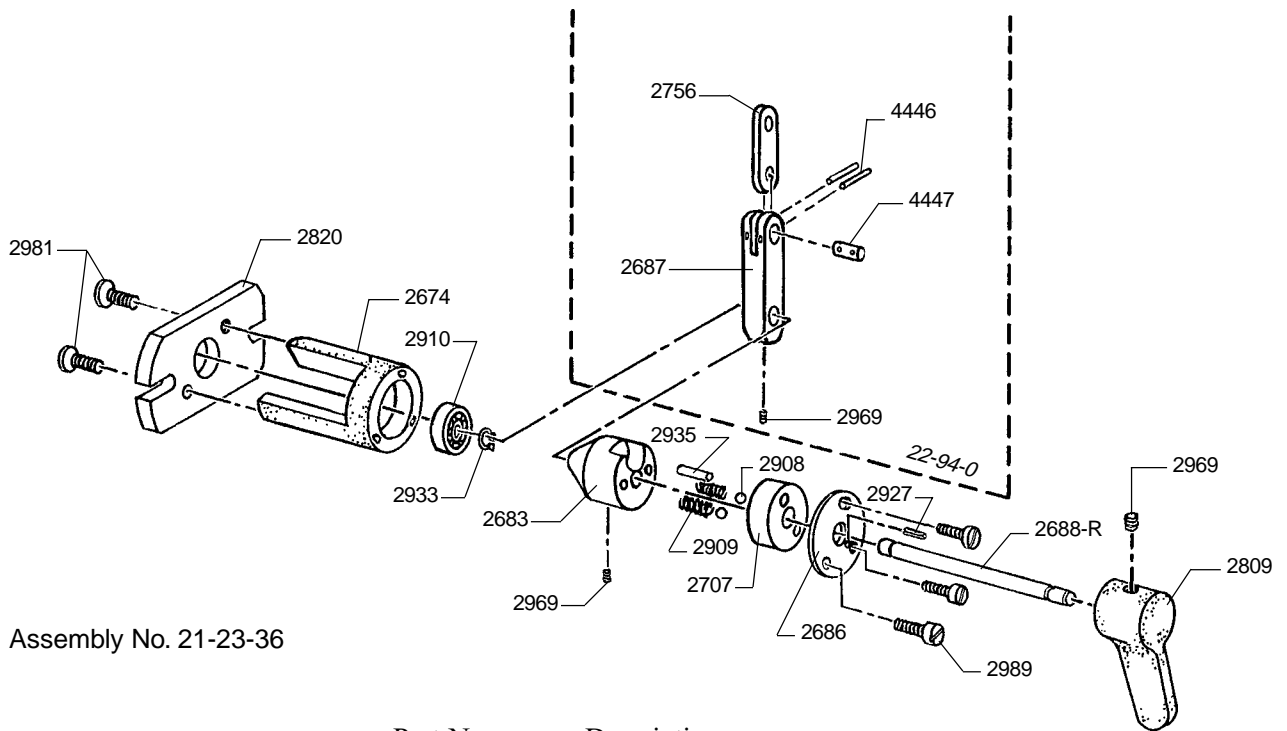

Assembly No. 21-23-36

<u>Part No.</u>	<u>Description</u>
22-94-0	Detent Elbow Assembly
2674	Detent Mount
2683	Idler Detent Mating Stud
2686	End Washer, Idler Detent Mount
2687	Order 22-94-0
2688-R	Detent Shaft
2707	Detent Stud
2756	Order 22-94-0
2809	Detent Lever
2820	Detent Plate
2908	Steel Ball, 3/16"
2909	Compression Spring
2910	Ball Bearing
2927	Roll Pin, 1/8 x 1/2"
2933	Snap Ring
2935	Dowel Pin, 3/16 x 5/8"
2969	Set Screw, 10-32 x 1/4"
2981	Allen Screw, 8-32 x 3/8" Flat Head
2989	Screw, 6-32 x 3/8" Fillister Head
4446	Roll Pin, 1/16 x 3/8"
4447	Connecting Pin, 13/64 x 3/8"

PAD ROLLER ASSEMBLIES

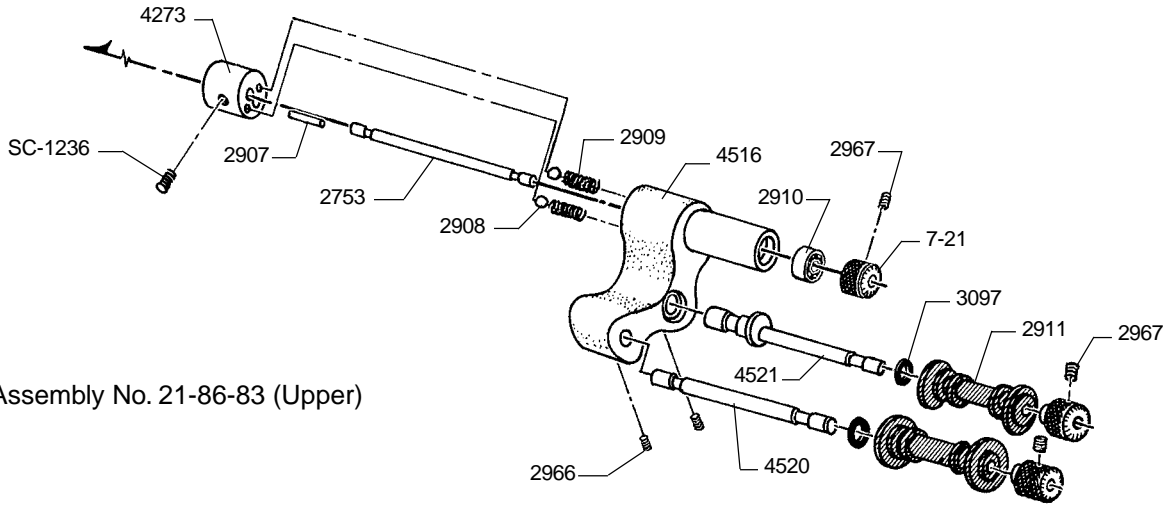

Assembly No. 21-86-83 (Upper)

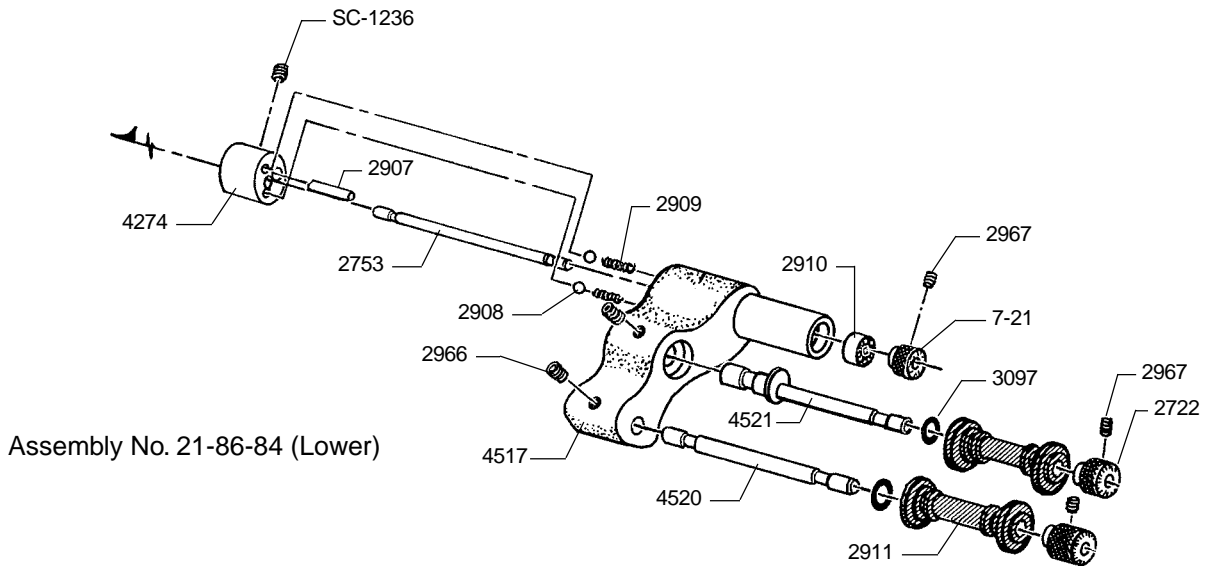

Assembly No. 21-86-84 (Lower)

PARTS LIST, Pad Roller Assemblies

<u>Part No.</u>	<u>Description</u>
2722	Knurled Collar, 7/32"
2753	Shaft, Pad Roller Arm
2907	Dowel Pin, Idler Detent; 3/16 x 7/8"
2908	Steel Ball, 3/16"
2909	Compression Spring
2910	Ball Bearing
2911	Pad Roller, Nylon (MNR-4-22)
2966	Set Screw, 10-32 x 1/8"
2967	Set Screw, 8-32 x 1/8"
3097	Fibre Washer, 1/94" Thick
4273	Upper Detent
4274	Lower Detent
4516	Upper Pad Roller Arm Casting
4517	Lower Pad Roller Arm Casting
4520	Pad Roller Arm Shaft, Straight
4521	Pad Roller Arm Shaft, Eccentric
7-21	Knurled Collar
SC-1236	Set Screw, 10-32 x 3/16"

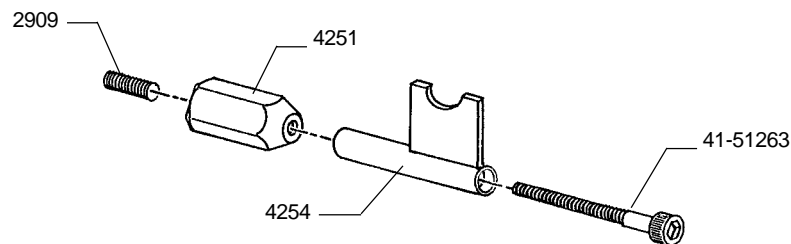

FILM STRIPPER
 Assembly No. P8114

<u>Part No.</u>	<u>Description</u>
2968	Set Screw, 1/4-20 x 1/2"
4231	Mounting Stud, Film Stripper
4254	Film Stripper
41-51263	Screw, 8-32 x 1-1/2" Socket Head

INTERMITTENT MOVEMENT

Assembly No. 82-02-84-6

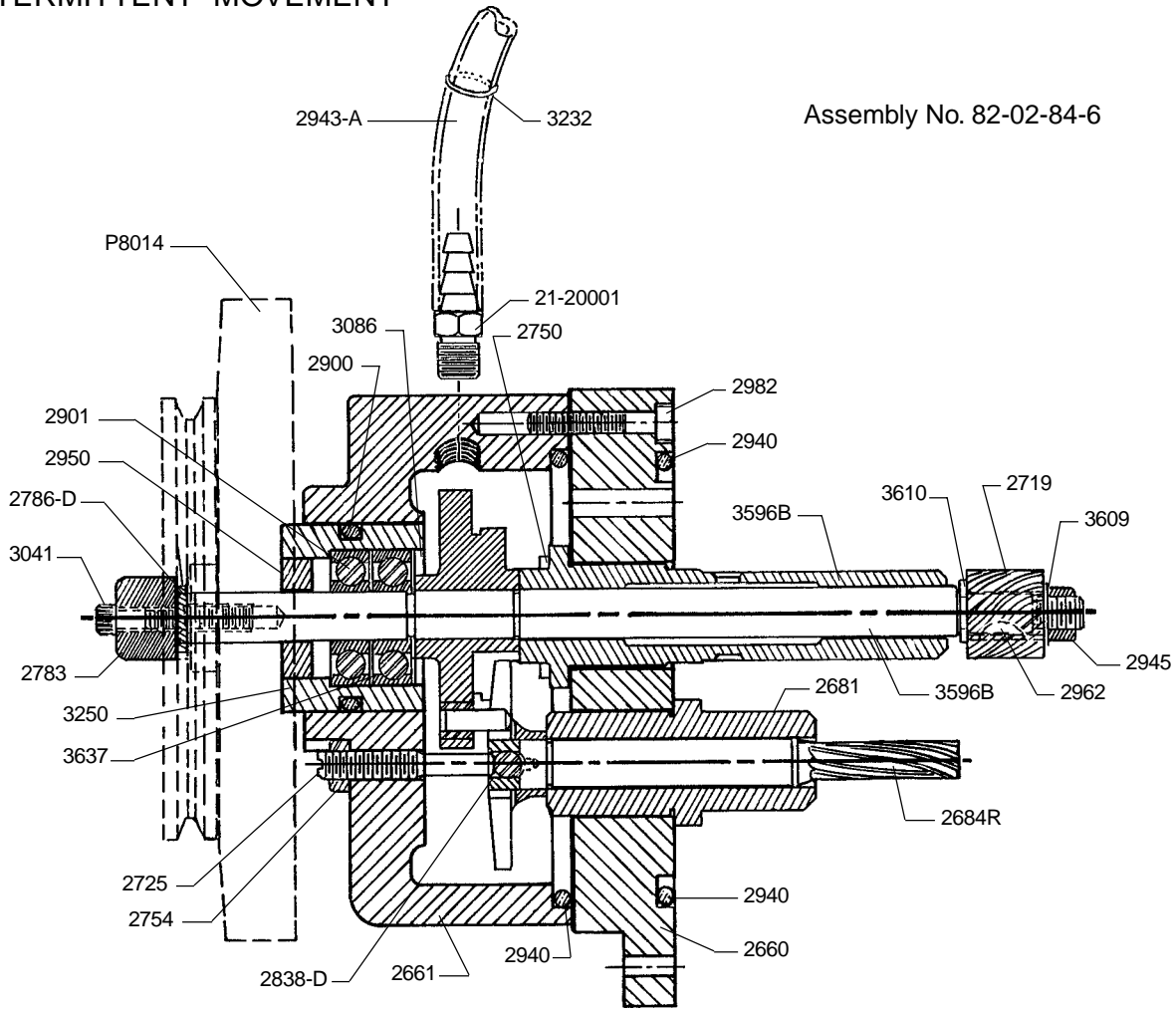

<u>Part No.</u>	<u>Description</u>
P8014	Flywheel & Pulley Assembly
2660	Intermittent Base Plate
2661	Intermittent Case
2698	Bushing, Starwheel Shaft
2684R	Starwheel Shaft
2719	Camshaft Drive Gear
2725	Stop Pin, Camshaft
2750	Locking Washer, Camshaft Bearing
2783	Cap, Flywheel Hub
2786-D	Nylon Washer (beneath Cap)
2838-D	Bushing, Nylon
2900	O-Ring

PARTS LIST, Intermittent Movement
(continued)

<u>Part No.</u>	<u>Description</u>
2901	Ball Bearing
2940	O-Ring
2943-A	Oil Fill Hose
2945	FlexLock Stop Nut
2950	Oil Seal
2954	Hex Nut, 1/4-28
2962	Woodruff Key, #203
2982	Screw, 10-32 x 1-1/4" Socket Head
3041	Screw, 10-32 x 3/4" Socket Head
3232	Oil Level Ring
3250	Bushing, Intermittent Case
3596B	Camshaft & Fitted Bushing
3609	Washer
3610	Slotted Washer
3637	Shim (.005"), Bearings

NOTE: Factory Rebuilt Intermittent Movements are available under a Repair/Exchange program. Contact an authorized Strong International Equipment Dealer for details. *Do not* return any goods to the factory without first requesting a **Return Authorization Number** from a Strong International Dealer. Strong International assumes no liability for products returned without a R.A. Number.

INTERMITTENT SPROCKET ASSEMBLY

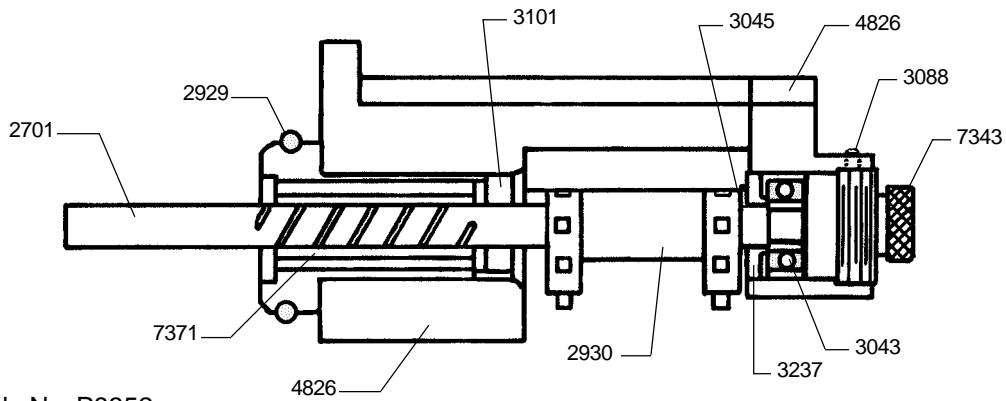

Assembly No. P8352

<u>Part No.</u>	<u>Description</u>
2701	Intermittent Sprocket Shaft
2929	O-Ring
2930	Intermittent Sprocket, 35mm VKF®
3043	Ball Bearing
3045	Felt Washer
3088	Set Screw. 10-32 x 1/4" Brass
3101	Oil Seal
3237	Bearing Bushing
4826	Sprocket Assembly Casting (Split)
5085	Film Stripper, Intermittent Sprocket (not shown)
41-51028	Stripper Mounting Screw (not shown), 6-32 x 1/4"
7343	Thumb Screw
7371	Bushing

FRAMING COUPLER

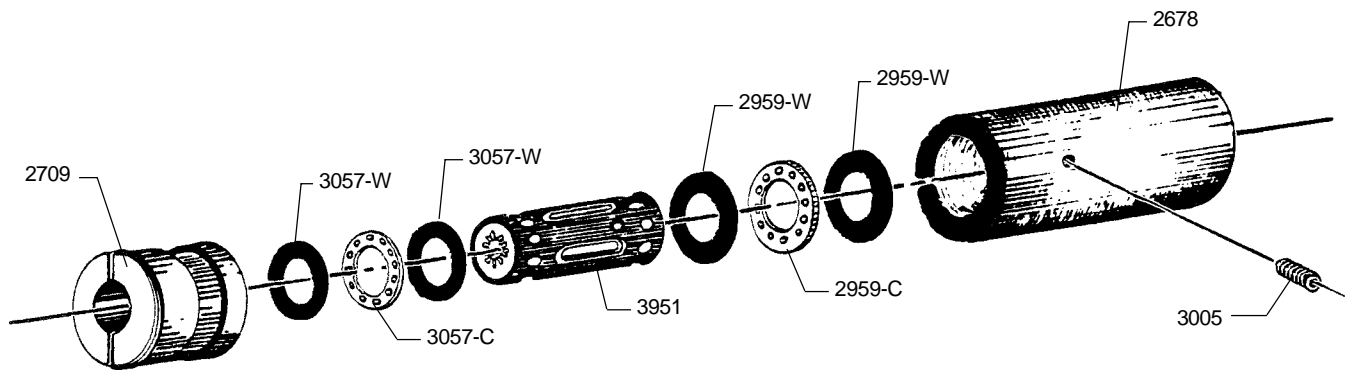

Assembly No. 62-31-59

<u>Part No.</u>	<u>Description</u>
2678	Housing, Framing Coupler
2709	Plug, Framing Coupler
2959-C	Cage Bearing
2959W	Thrust Washer
3005	Set Screw, 6-40 x 1/8"
3057-C	Cage Bearing
3057-W	Thrust Washer
3951	Spline

TOP PLATE SUB-ASSEMBLIES

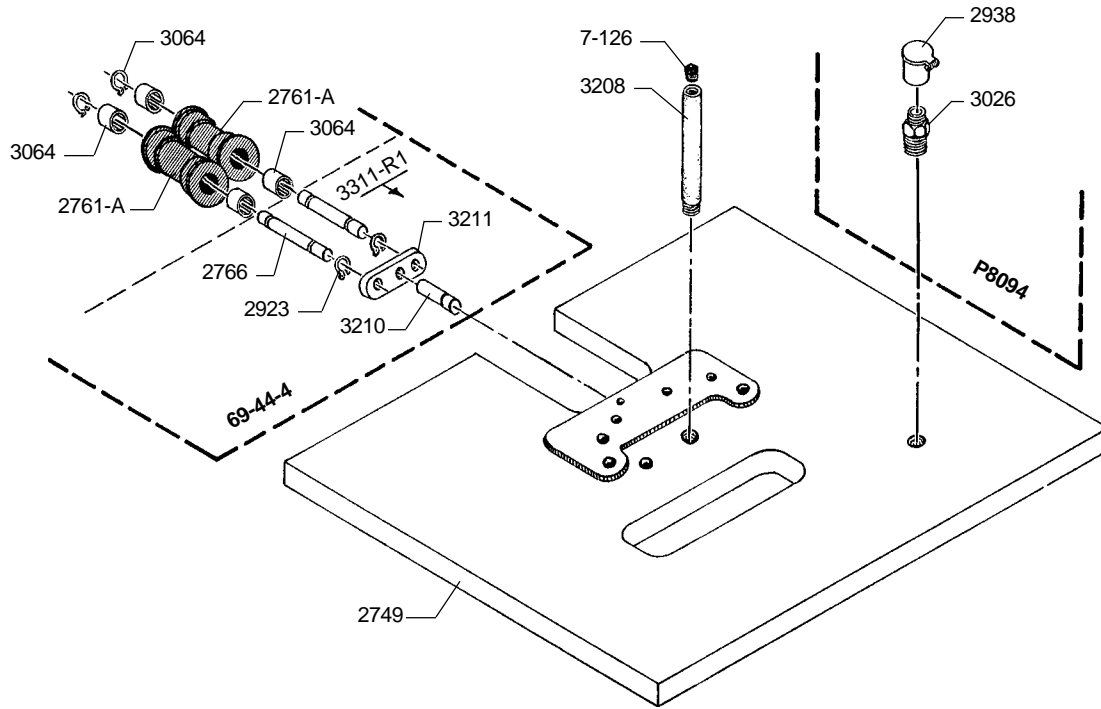

<u>Part No.</u>	<u>Description</u>
69-44-4	Double Roller Assembly, 35mm
P8094	Oil Filler Assembly
P8105	Roller & Bearing Assembly
2749	Top Plate Casting
2761-A	Roller (Order P8105)
2766	Roller Shaft
2923	Snap Ring
2938	Oil Cup
3026	Fitting, Oil Cup
3064	Needle Bearing
3208	Breather Tube
3210	Shaft (Order 3211-R1)
3211	Block (Order 3211-R1)
3211-R1	Block & Shaft Assembly
7-126	Pipe Plug, Nylon

BELT TENSION ROLLER

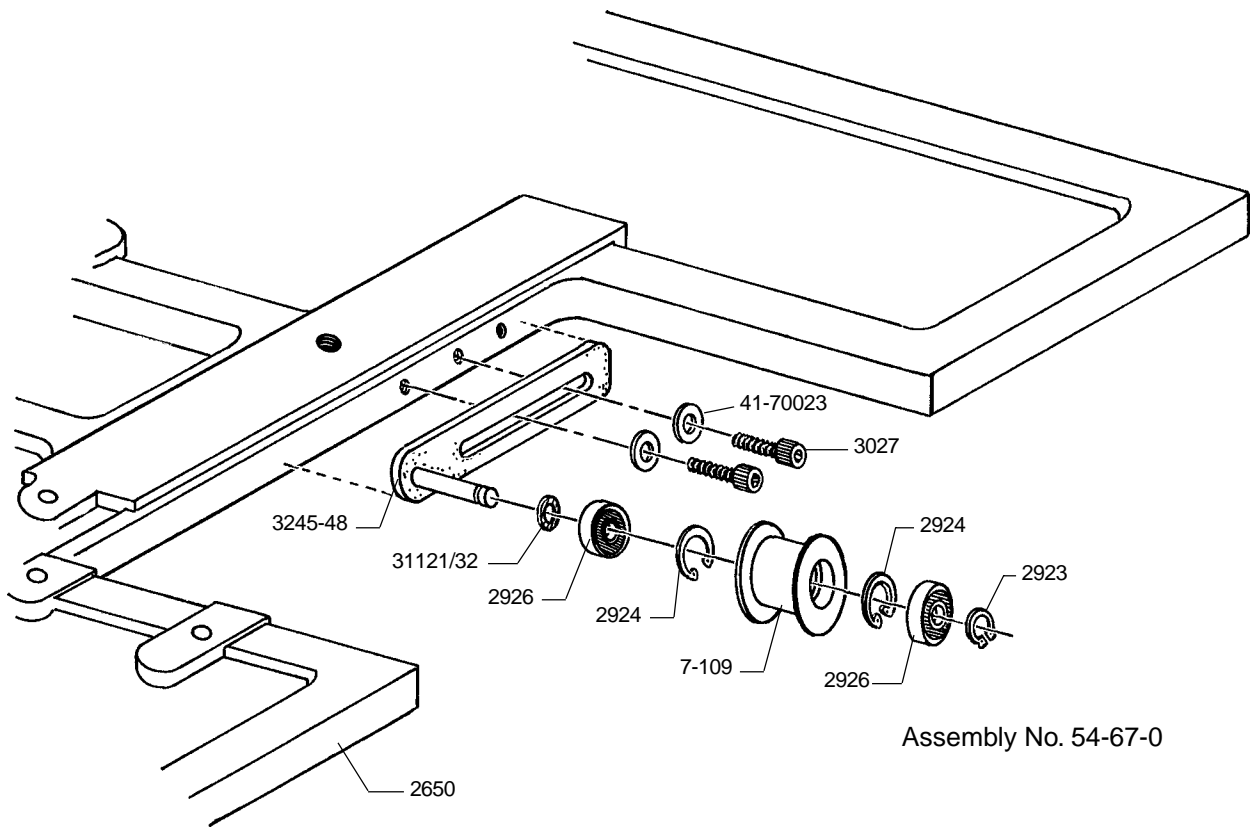

<u>Part No.</u>	<u>Description</u>
3245-48	Idler Arm & Shaft Assembly
7-109	Drive Belt Idler Pulley
2650	Base Casting
2923	Snap Ring
2924	Snap Ring
2926	Ball Bearing
3027	Screw, 1/4-20 x 3/4" Socket Head
31121/32	Fibre Washer
41-70023	Flat Washer, 1/4"

FILM GUIDE ROLLER

Assembly No. 26-15-0

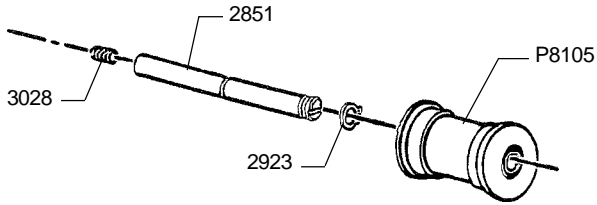

<u>Part No.</u>	<u>Description</u>
P8105	Roller Assembly
2851	Roller Shaft
2953	Snap Ring
3028	Set Screw, 10-32 x 3/8"

OIL DRAIN

Assembly No. 37-67-9

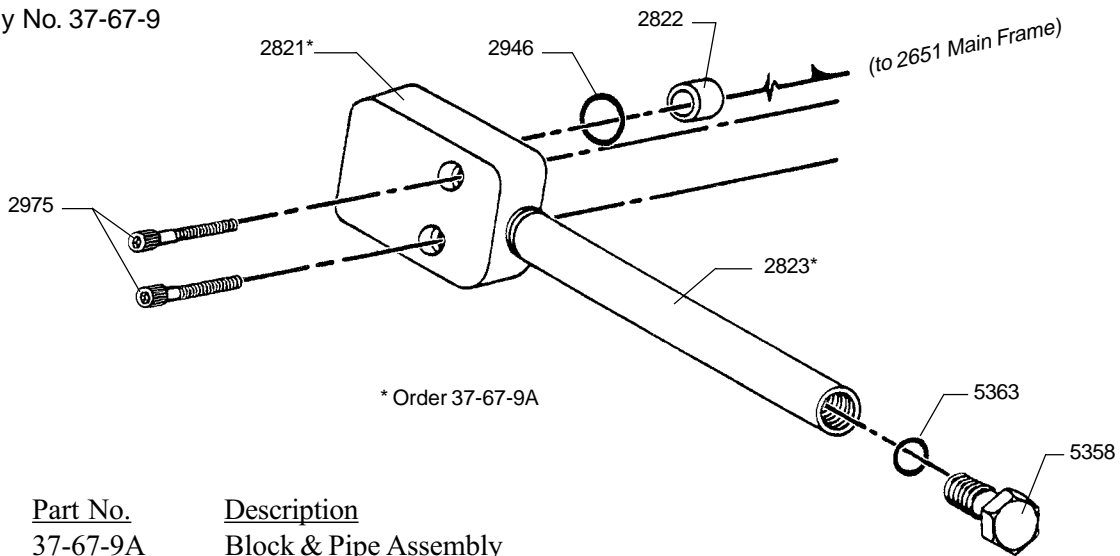

* Order 37-67-9A

<u>Part No.</u>	<u>Description</u>
37-67-9A	Block & Pipe Assembly
2821	Drain Block*
2822	Bushing
2823	Drain Pipe*
2946	O-Ring
2975	Screw, 10-32 x 1" Socket Head
5358	Pipe Plug
5363	O-Ring
*	Order 37-67-9A; Sold as Assembly Only

DRIVE MOTOR, 115 V.AC INDUCTION

Assembly No. P8236

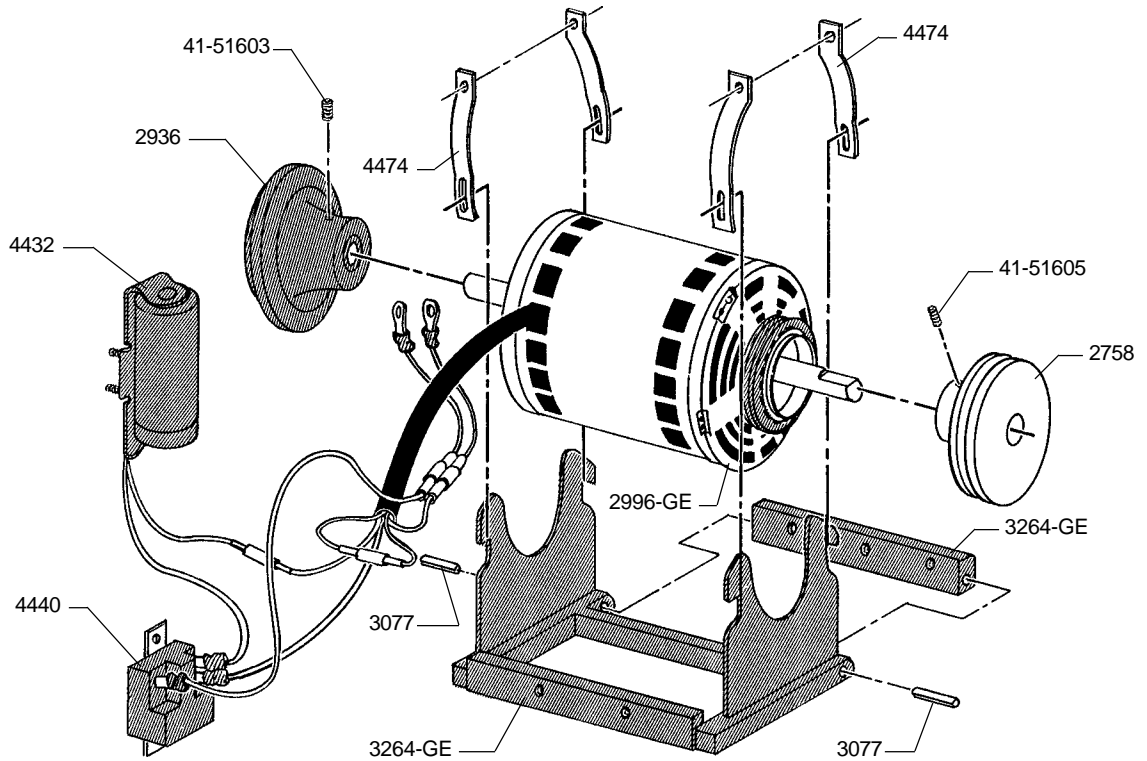

<u>Part No.</u>	<u>Description</u>
2758	Drive Pulley
2936	Inching Knob
2996-GE	Drive Motor, 115 V.AC, 60 Hz.
3044	Drive Belt, 2L300 (not shown)
3077	Roll Pin, 3/16 x 3/4"
3264-GE	Motor Cradle & Mounting Bar
4440	Order 21-45030 Relay
4432	Capacitor
4474	Strap
41-51603	Set Screw, 10-32 x 1/4"
41-51605	Set Screw, 1/4-20 x 3/8"

DRIVE MOTOR, 230 V.AC INDUCTION

Assembly No. P8237A

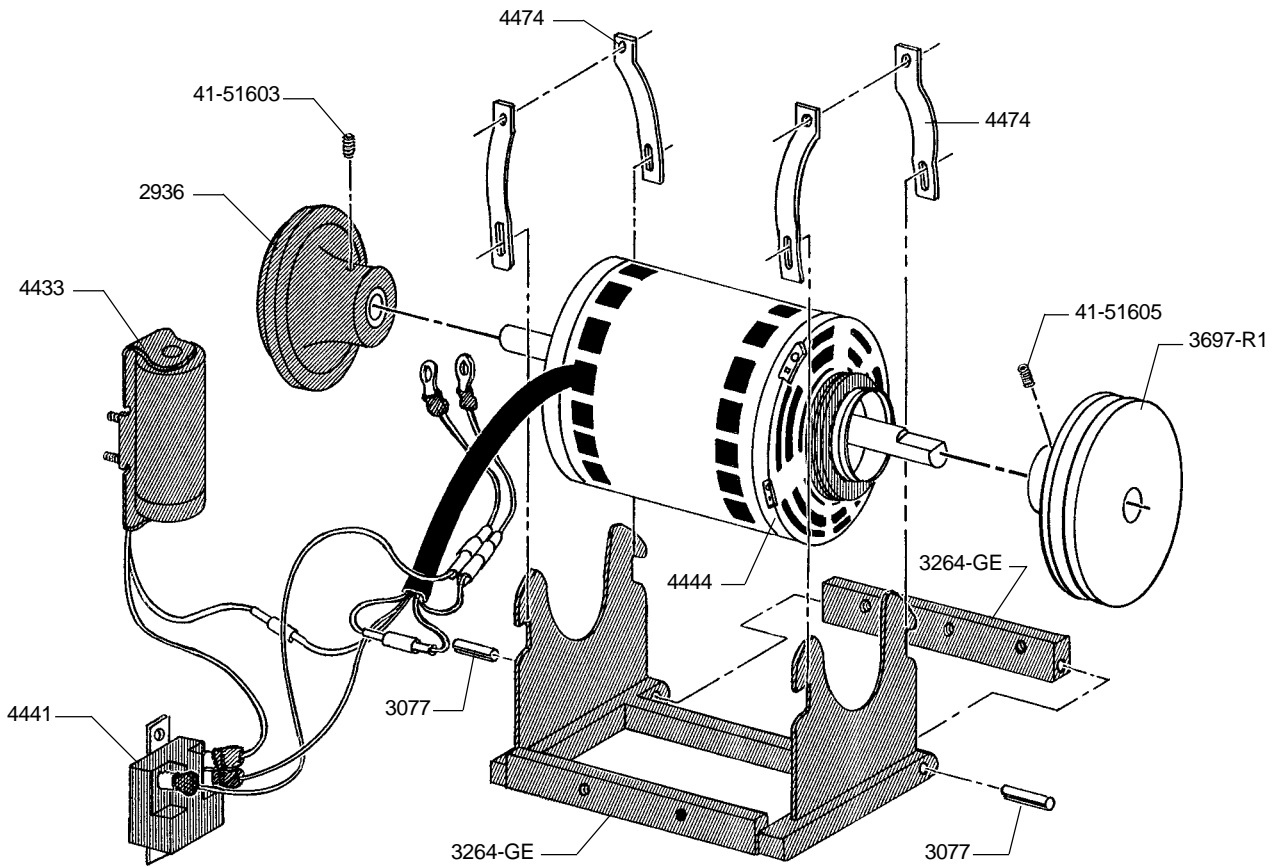

<u>Part No.</u>	<u>Description</u>
2936	Inching Knob
3044	Drive Belt, 2L300 (not shown)
3077	Roll Pin, 3/16 x 3/4"
3264-GE	Motor Cradle & Mounting Bar
3697-R1	Drive Pulley
4433	Capacitor
4441	Order 21-45031 Relay
4444	Drive Motor, 230 V.AC, 50 Hz.
4474	Strap
41-51603	Set Screw, 10-32 x 1/4"
41-51605	Set Screw, 1/4-20 x 3/8"

DRIVE MOTOR, 115 V.AC SYNCHRONOUS

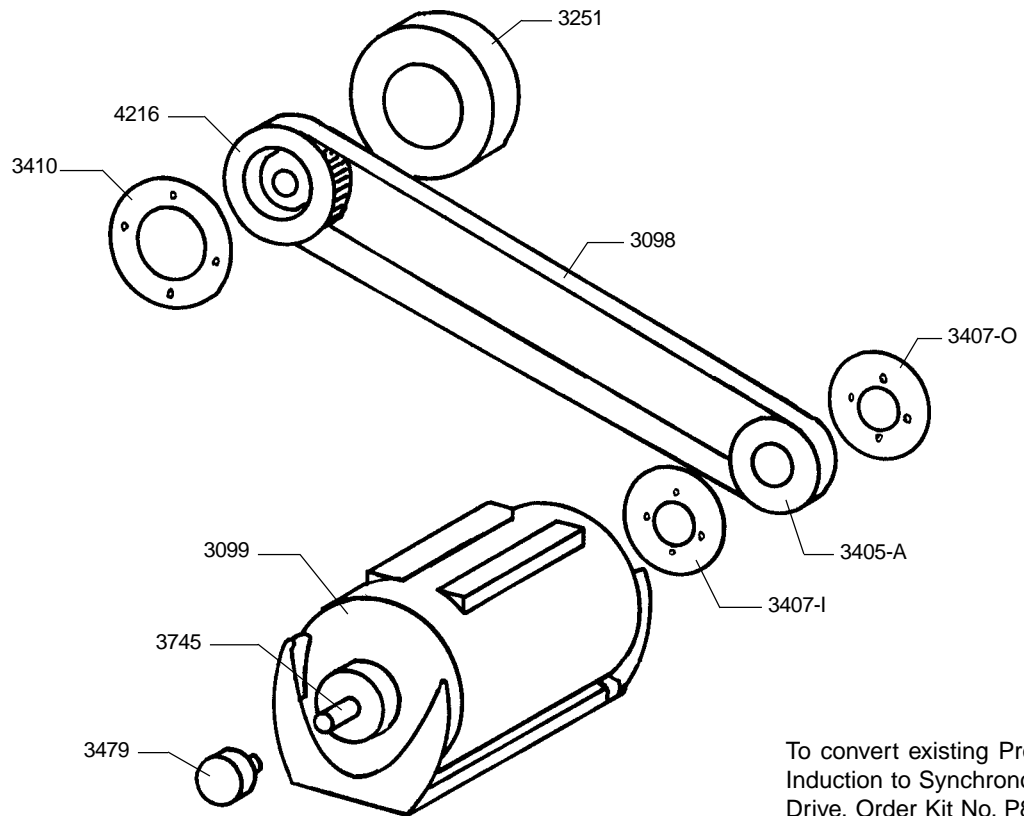

To convert existing Pro-35 from Induction to Synchronous Motor Drive, Order Kit No. P8021.

<u>Part No.</u>	<u>Description</u>
3098	Timing Belt, 274XL037
3099	Synchronous Motor, 115 V.AC, 60 Hz.
3251	Intermittent Flywheel
3405-A	Intermittent Drive Pulley
3407-I	Pulley Flange, Inner
3407-O	Pulley Flange, Outer
3410	Spacer
3479	Inching Knob
3745	Shaft Extension
4216	Intermittent Driven Pulley

PARTS NOT ILLUSTRATED

Projector Cabinet

<u>Part No.</u>	<u>Description</u>
C-D	Film Compartment Door & Hinge
2960	Door Glass
C-M	Glass Retaining Plate
C-N	Glass Retaining Angle
C-K	Door Strike
7-178	Door Handle, Film Compartment
C-E	Shutter Guard/Quarter Panel
C-C	Drive Compartment Door & Hinge
C-A	Rear Panel, Projector Cabinet
C-L	Door Strike (for C-C)
7-178	Door Handle
C-B	Front Panel, Projector Cabinet
C-H	Belt Tensioning Plate (early models)
SM1S	Cabinet Front Panel, early sync drive models

Aperture Plates

3387	Pinhole
3388	Flat (Wide Screen; non-anamorphic)
3389	Anamorphic (CinemaScope)

CHANGEOVER & FRAMING LIGHT POWER SUPPLY

Assembly No. 6968

<u>Term. No.</u>	<u>Function</u>
1	Changeover Coil
2	Changeover Coil
3	Framing Light
4	Framing Light
5	C/O Close (Pulsed)
6	C/O Close (Held)
7	C/O Common
8	C/O Open
9	Input 120 V.AC Phase
10	Input AC Neutral

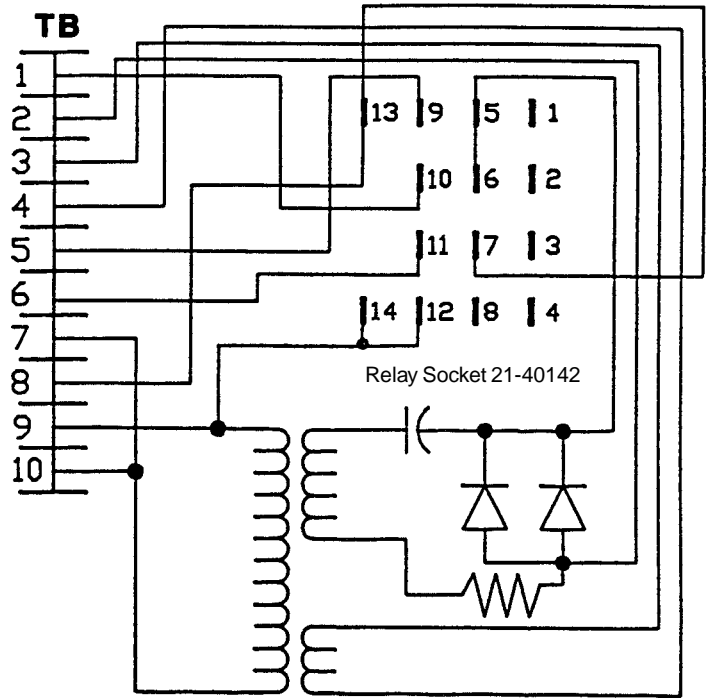

Pulsed Relay 21-45050 Installed

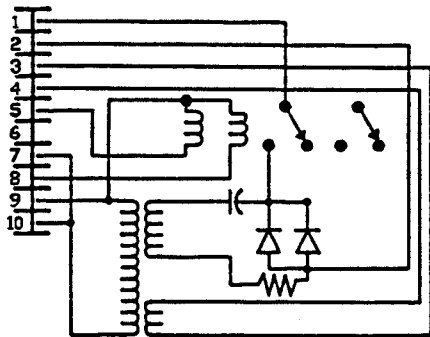

Held Relay 21-45038 Installed

