

Film-Tech

The information contained in this Adobe Acrobat pdf file is provided at your own risk and good judgment.

These manuals are designed to facilitate the exchange of information related to cinema projection and film handling, with no warranties nor obligations from the authors, for qualified field service engineers.

If you are not a qualified technician, please make no adjustments to anything you may read about in these Adobe manual downloads.

www.film-tech.com

THE POTTS PLATTER

WHAT MAKES IT BETTER?

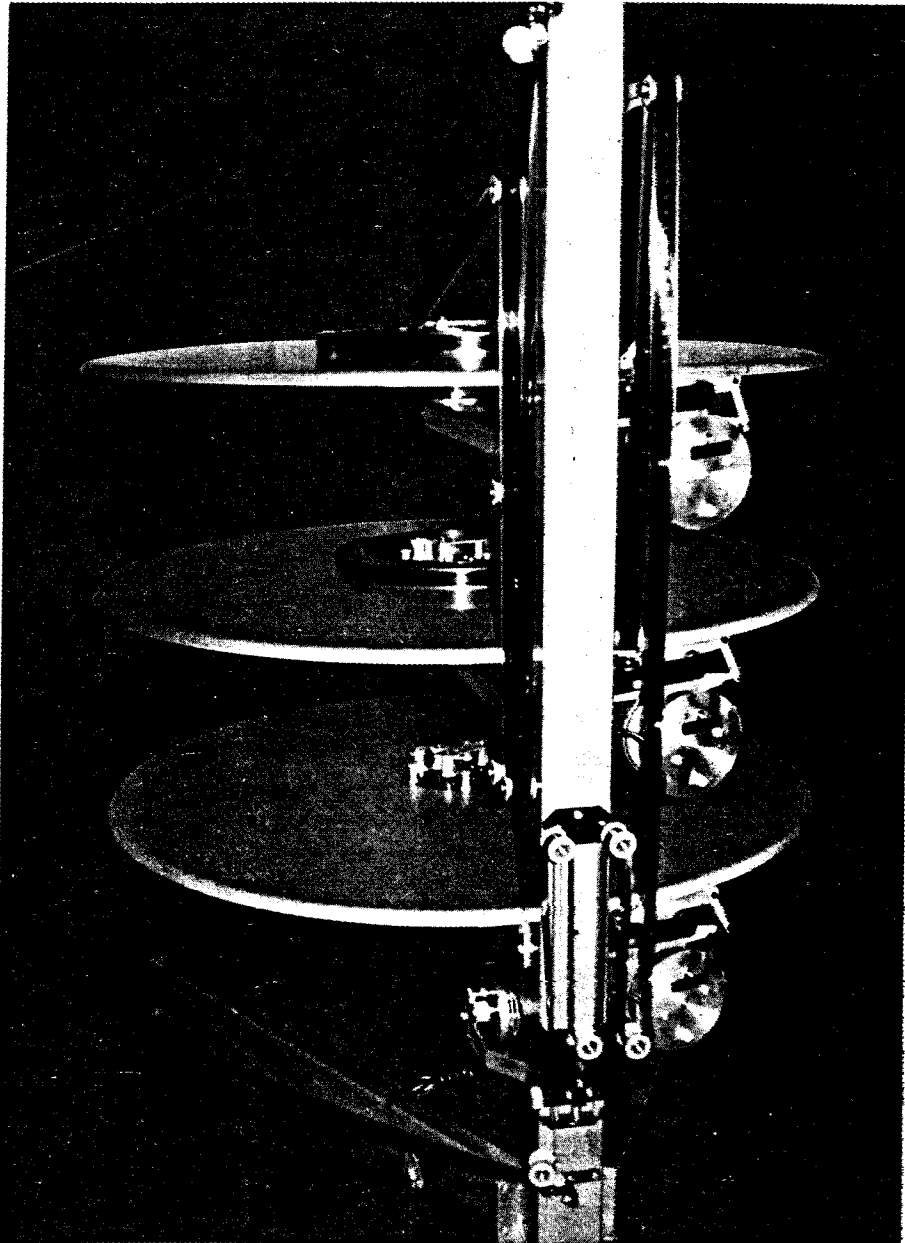

OUTSTANDING FEATURES

Ball bearing mounted nylon rollers

Built in fail-safe

Anodized and rolled aluminum platters

In excess of 1 hp. motors

Platter lighting

No swing arms to interfere

Make-up and take-down can be done at super fast speeds

Make-up table doubles as a rewind bench

All platter make-up for both 3 & 5 platter machines

Variable transformer control

Simple construction

Highly reliable

Very low initial and operating cost

THE POTTS PLATTER

GOOD DEALERS HAVE IT

For further information, call or write to Robert Potts
R. R. #2 Urbana, Illinois 61801 Ph. 217-469-7578

SUZIE
ILL

(217) 893-0443

DISC SPEED ADJUSTMENT

Turn switches on disc drive notors to the center (off) position. Put the speed control carriage in position with the spring loaded plunger in the hole in the upright post. Put a piece of tape on the outer edge of each disc. Turn the switch on the center disc drive notor to the take-up position. Time the center disc speed. It should make one revolution in from three to four seconds. Switch the top motor to take-up position also. Manually stall the top and center disc so that the pieces of tape are in line vertically with each other. Release the discs at the same time. After one revolution, the pieces of tape should be within six inches of being in line. Repeat stalling, release, and alignment of tape for center to bottom disc. Adjustment is made by tightening or loosening the two socket head cap screws on the drive motor mounting bracket. Tightening the screws decreases the speed of the disc. Both screws should be turned the same amount to prevent misalignment.

NOTE

The nuts on the asjstment screws are locking nuts and must be loosened before adjustment and retightened after adjustment.

On the five disc system, compare the speed of both of the discs above and below the center disc to the speed of the center disc. Both speed carriages must be in position with the spring plungers in the holes in the upright post. The switch on the side of the upright post above the center disc must be up to check the upper disc speeds and down to check the lower disc speeds.

NOTE

You will not get an accurate tune if more than two motors are on.

OPERATION OF THE PLATTER

Pull the knob on the expandable ring, this allows the ring to collapse. Gently lift the ring out of the center of the film, expand it and place it in the holes provided in another place.

The platter with the film left in it is called the feed-out platter. The one with the ring in it is called the take-up platter.

Lift the carriage at the rear of the machine and push the pin into the hole in the column, This turns the power on to the platter system and the failsafe outlet on the variable transformer.

Take the leader from the center of the feed-out platter and thread it through the "brain" (center control device). Next, throw the motor switch to the feed-out position. This will allow the film to be fed to you during the rest of the thread-up operation.

Finish threading up as shown in the diagrams. "Note", the sound track should be up when wound on to the platter and toward the column at the topmost rollers on the take-up side of the column.

Hook the film into the take-up ring and take up the excess film by turning the platter by hand until the pin pops out on the carriage at the back of the column.

Throw the switch for the motor driving the platter with the take-up ring in it, to take-up. You are now ready to start the projector.

Always double check your work and programming.

MAKE-UP

Before plugging the grounded outlet plug into a 110/120V AC power source, make sure that the speed control knob is turned clockwise until it stops. The control switch should be in the make-up position. Disconnect the motor on platter to be used by twisting the cord connector to the left and unplugging it. Pull on the extension cord from side of the table top and connect it to the platter that has just been disconnected twisting in a clockwise manner.

With the platter drive motor shift lever in the "drive" position, and the motor switch in "feed-out/make-up position, the speed of the platter can be controlled by the speed control knob in the front of the table.

Place an expandable ring onto the platter with the pins inserted into the holes provided. Make sure that the ring is in its expanded position.

Add necessary leader to the first reel. Place reel on extended arm spindle. Thread leader through table to platter.

Film should always be sound track up at take-up ring and make-up table reel.

Rotate the platter counterclockwise by hand for at least two revolutions to insure that the film is securely in place. Slowly turn the speed control knob counterclockwise. The film should now wind evenly and smoothly onto the platter. Near the end of the reel, reduce the speed by turning the control knob to the right in order to prevent damage to the film.

Remove the tail from the first reel and leader from the second reel, and splice to the first reel and continue winding until the entire feature is on the platter.

Reconnect drive motor to its platter control plug on column.

The make-up table can be used as a rewind bench or an inspection station also.

BREAK DOWN

Set the film speed control at zero. Disengage the drive wheel of the disc with the program to be broken down. Place take-up reel on the powered spindle of the table. Thread film through table rollers and onto reel in a clockwise direction with the sound track up. Put the switch on the table in the "rewind" position. The speed of the take-up reel is now controlled by the film speed control.

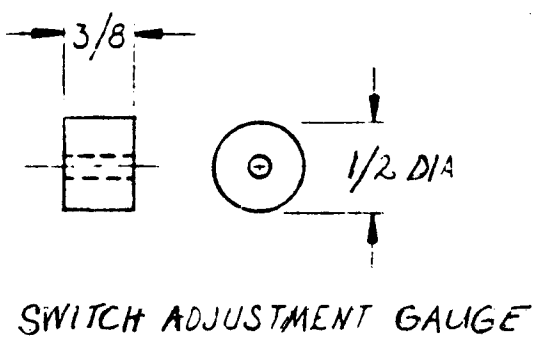
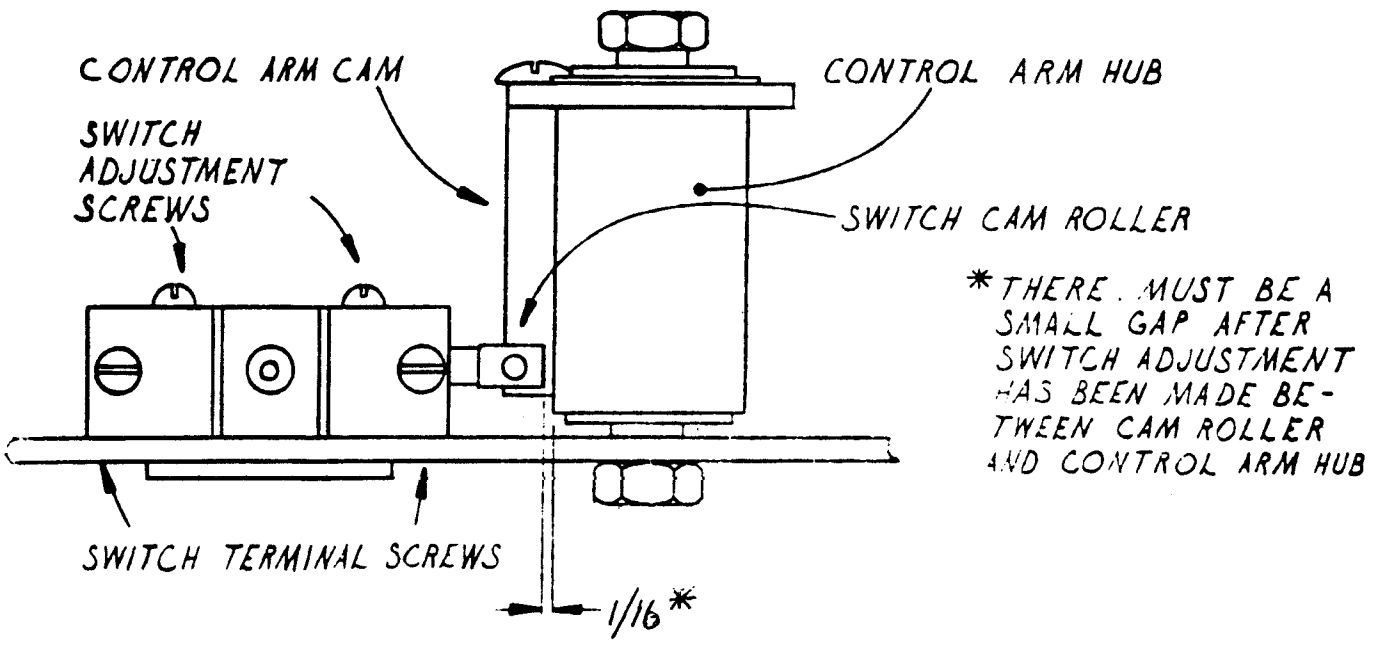
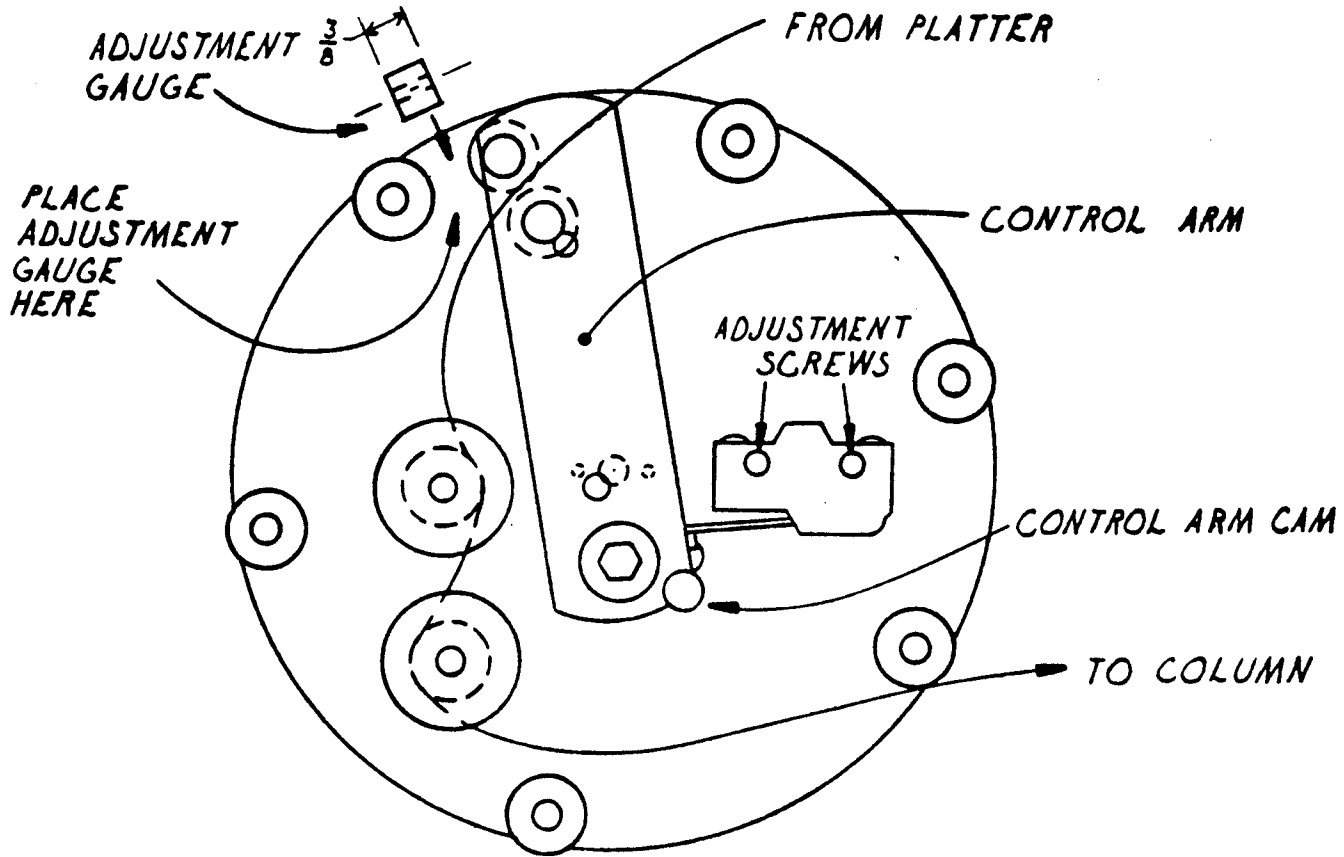

FEED-OUT PLATE PARTS
AND ADJUSTMENTS

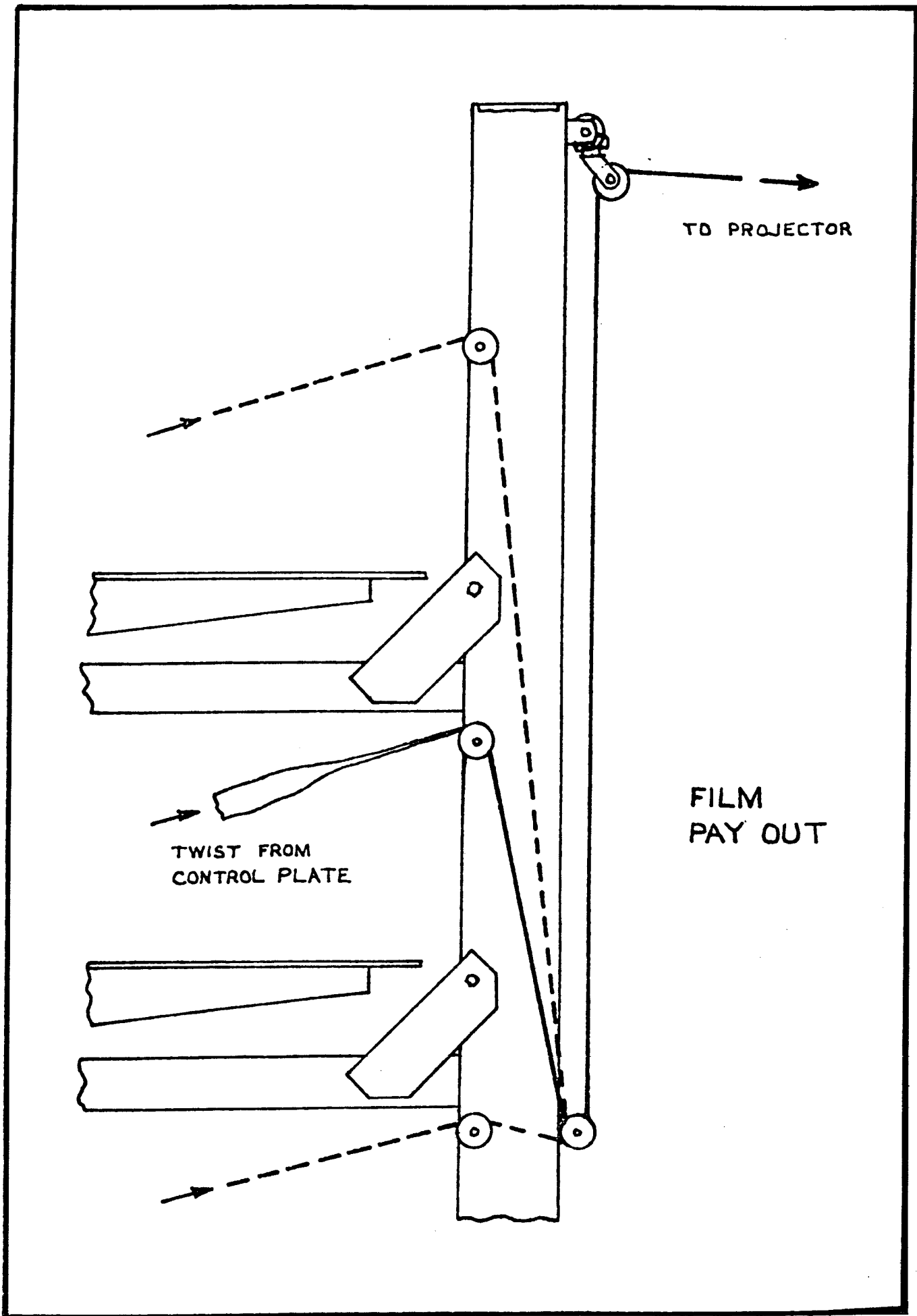

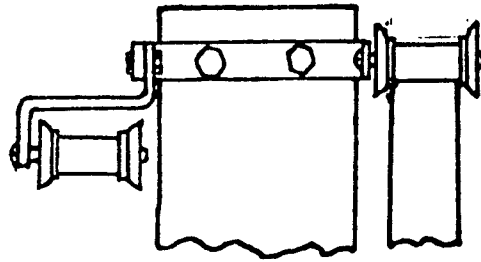

TWIST TO
TOP PULLEY
BRACKET

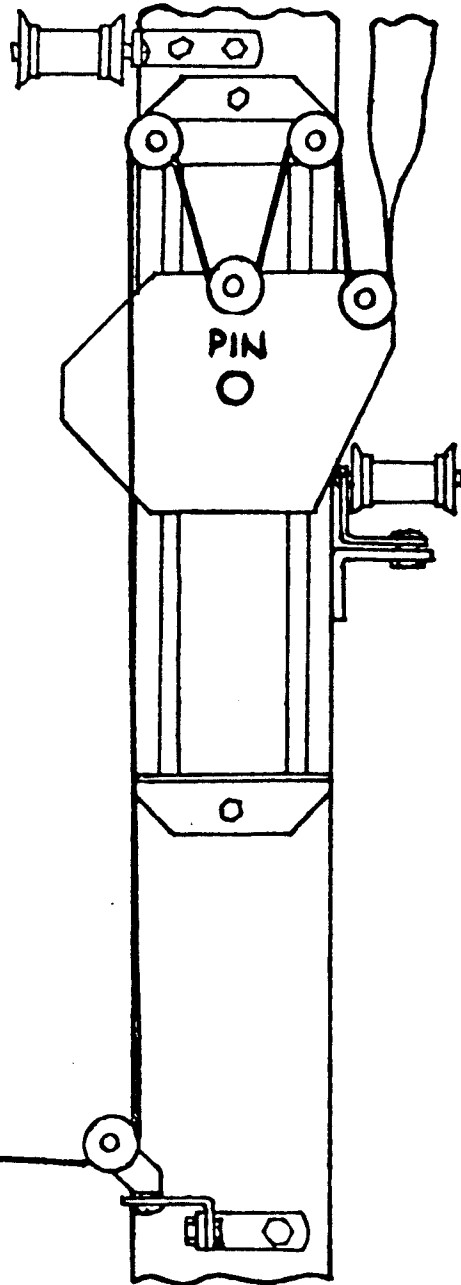

VARIAC
CONTROL
FILM
THREADING



FROM PROJECTOR

TOP PULLEY
BRACKET

FROM VARIAC
SLIDE CONTROL

TWIST TO
FILM DISK

FILM
RETURN

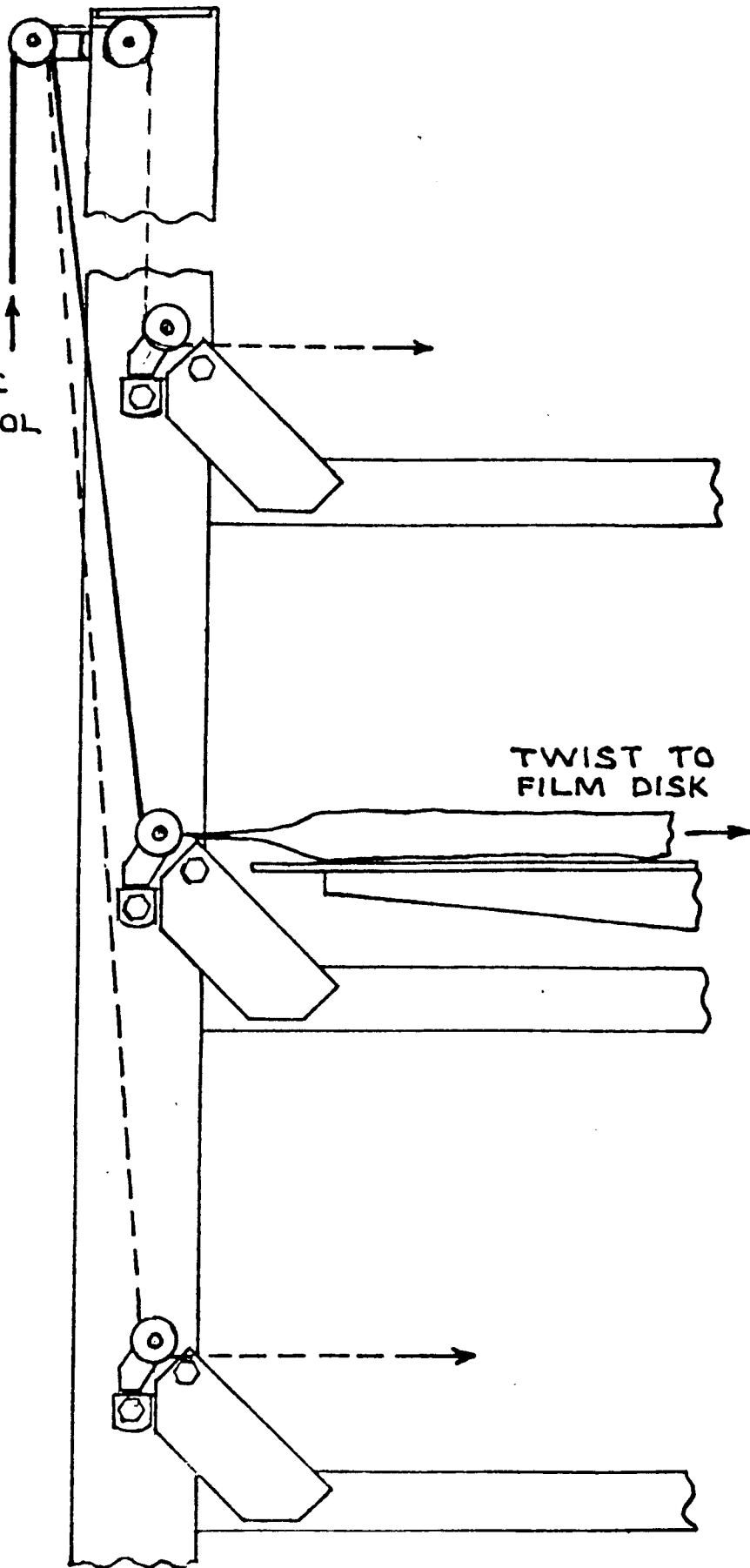

NOTE: To LEFT PROJECTOR
 ALWAYS GO OVER TOP
 OF PULLEY WHEN
 LEAVING PLATTER.

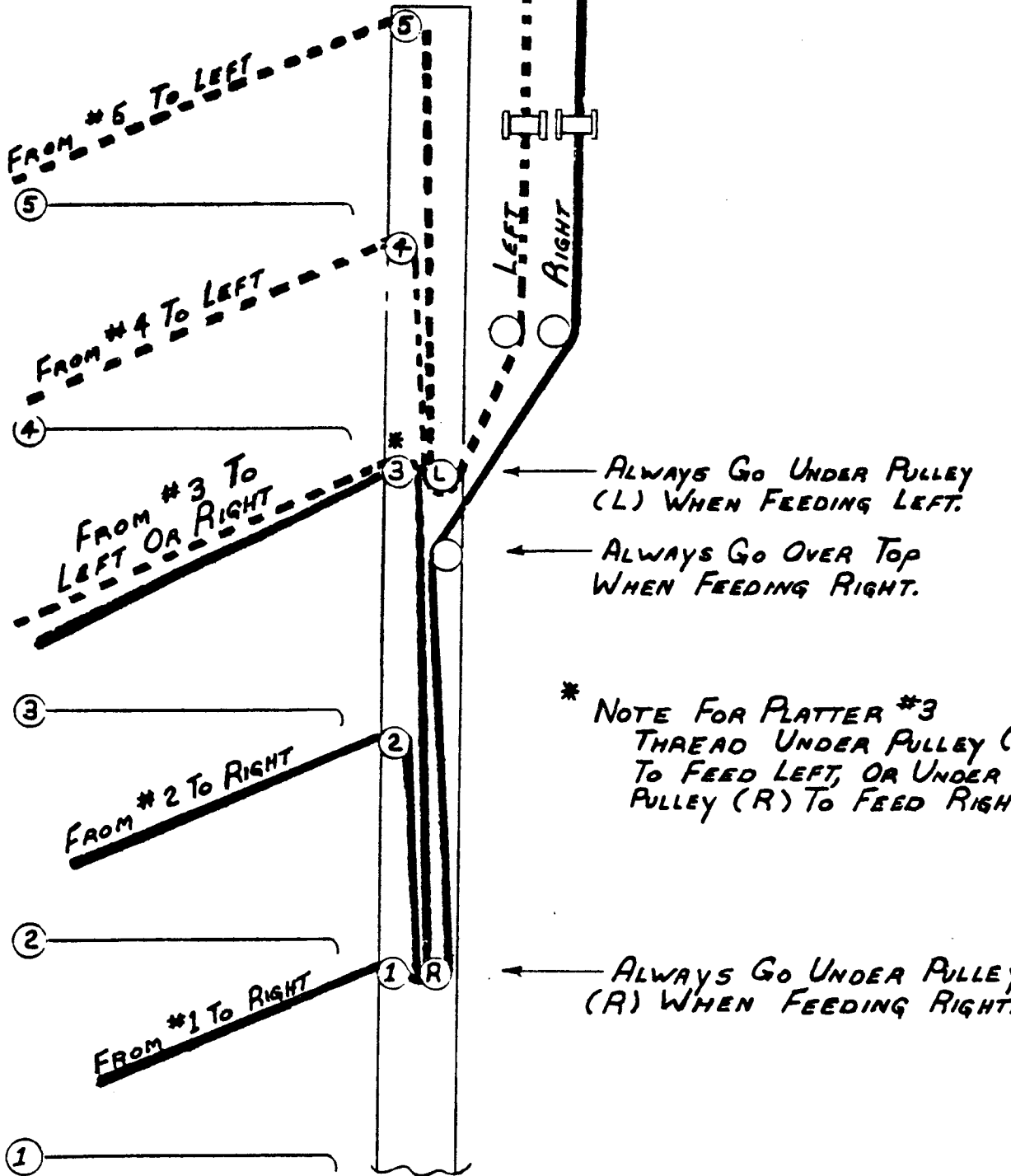

FILM FEED DIAGRAM

LEFT SIDE OF COLUMN

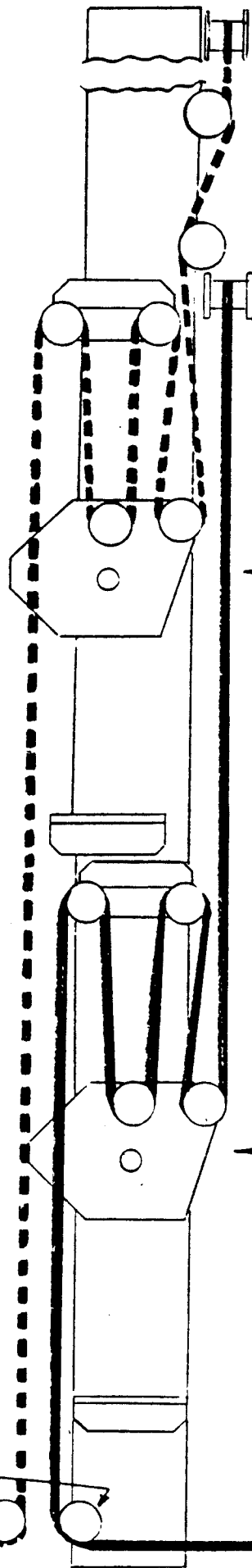

FILM RETURN ROLLER
FOR PLATTERS 5, 4, AND 3

FILM RETURN PULLEY
FOR PLATTERS 3, 2 AND 1

UPPER FILM TAKE-UP FOR
PLATTERS # 5, 4 AND
PLATTER # 3 IF THE PLATTER
3 SWITCH IS IN THE UP
POSITION

LOWER FILM TAKE-UP FOR
PLATTERS #1, 2, AND PLATTER
#3 IF PLATTER #3 SWITCH
IS IN THE DOWN POSITION

BOTTOM SET OF
CASTORS

FROM LEFT
PROJECTOR

FROM RIGHT PROJECTOR

COLUMN BACK

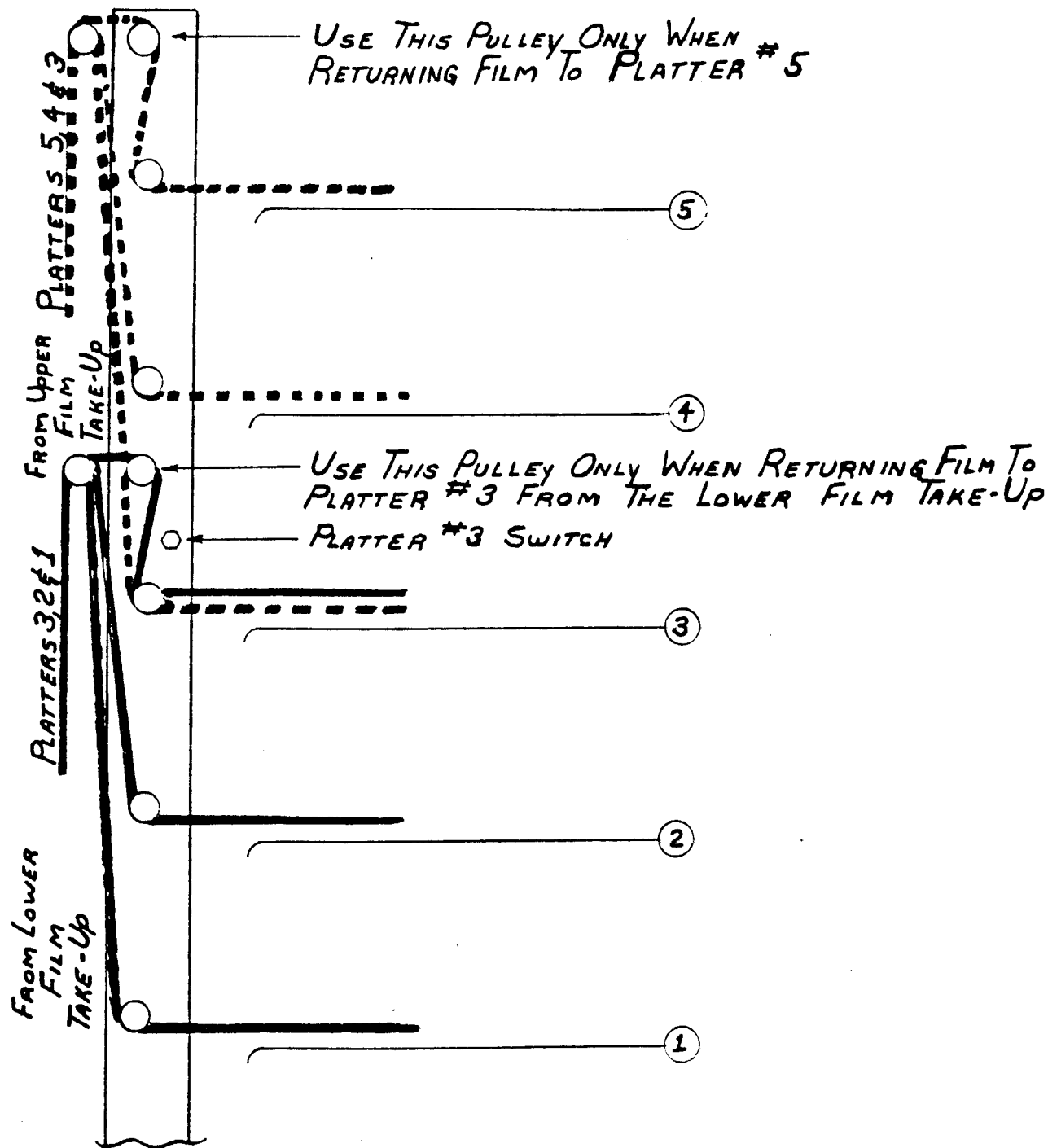

FILM RETURN FROM PROJECTOR
RIGHT SIDE OF COLUMN

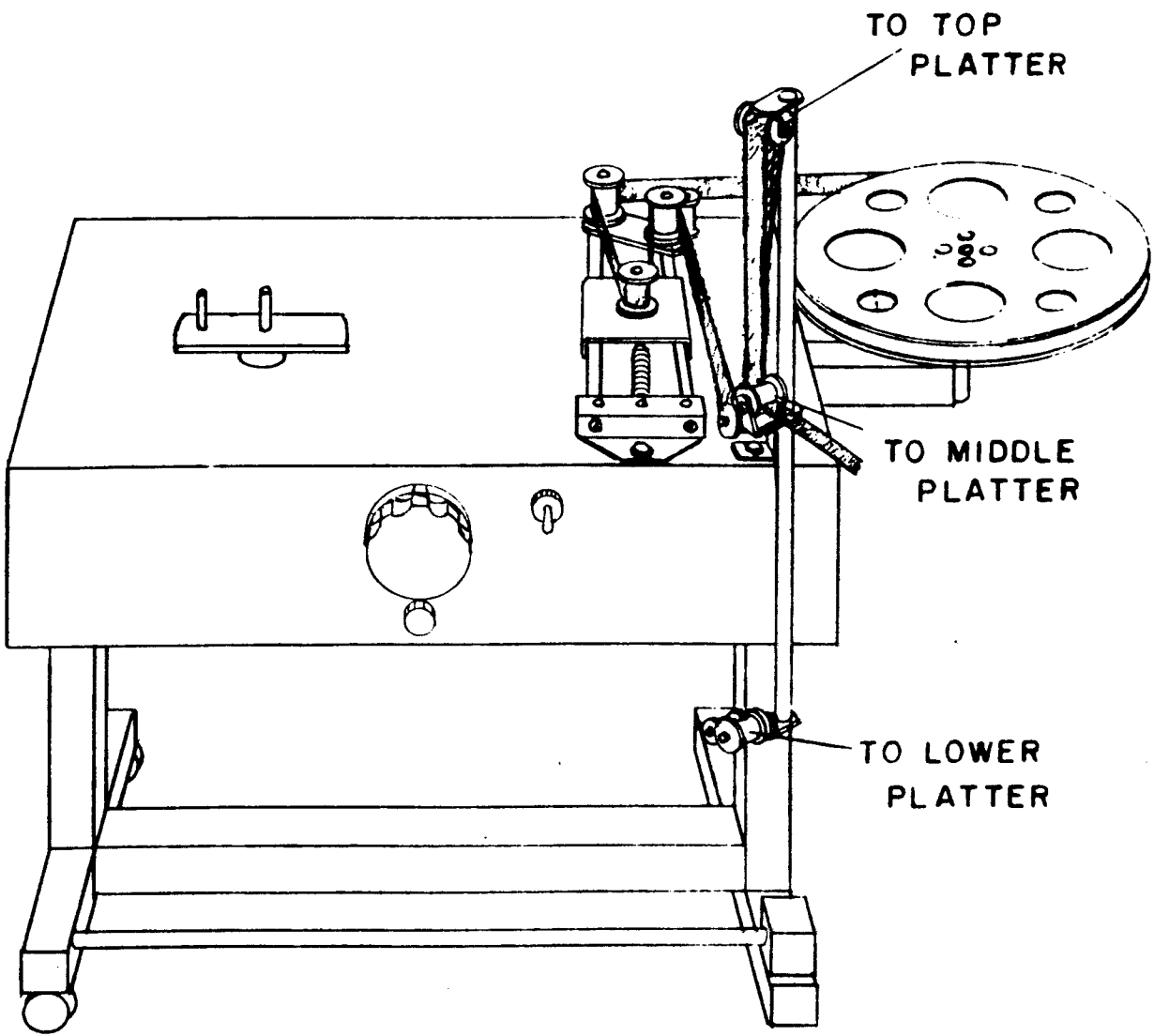

TO TOP
PLATTER

TO MIDDLE
PLATTER

TO LOWER
PLATTER

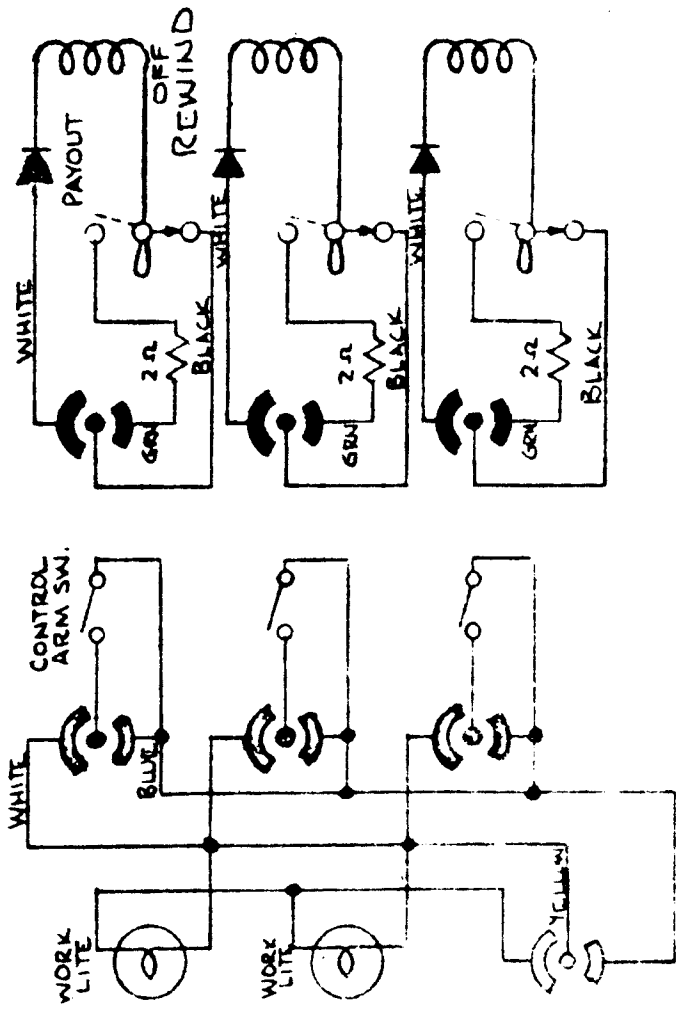

WIRING DIAGRAM

TROUBLE SHOOTING

- A. If the system fails to turn on:
 - 1. Check the power source.
 - 2. Check the fuse in the variable transformer.

- B. If the platter does not turn for film make-up make sure that:
 - 1. The platter motor is disconnected from the column and plugged into the extension cord.
 - 2. The platter motor switch is turned to make-up.
 - 3. The motor is engaged to the bottom of the platter.

- C. If the film fails to transfer from the platter to the table make sure that:
 - 1. The motor is disengaged from the platter.
 - 2. The control switch on the table is thrown to the rewind position.

- D. If the feed-out platter does not operate make sure that:
 - 1. The motor switch is turned to feed-out.
 - 2. The motor is engaged against the platter.
 - 3. The control arm works freely.

- E. If the take-up platter fails to operate make sure that:
 - 1. The motor switch is turned to the take-up position.
 - 2. The fuse is not blown.