

Film-Tech

The information contained in this Adobe Acrobat pdf file is provided at your own risk and good judgment.

These manuals are designed to facilitate the exchange of information related to cinema projection and film handling, with no warranties nor obligations from the authors, for qualified field service engineers.

If you are not a qualified technician, please make no adjustments to anything you may read about in these Adobe manual downloads

www.film-tech.com

MMP-10

Multiplexer

INSTRUCTION MANUAL



Ultra★Stereo Labs, Inc. • 181 Bonetti Drive
San Luis Obispo, CA 993401

Telephone 805.549.0161 • e-mail usl@uslinc.com

Limited Warranty



Ultra*Stereo Labs , Inc. warrants that the MMP-10 will be free from defects in material and workmanship under normal usage for a period of ninety (90) days after its purchase new from an authorized dealer. Our obligation under this warranty is limited to repairing or replacing any product or component which we are satisfied does not conform with the foregoing warranty and which is returned to our factory, freight paid, or serviced by one of our authorized contractors. The foregoing Warranty is exclusive and in lieu of all other warranties, whether expressed or implied. Such warranty shall not apply to any product or component (A) repaired or altered by anyone other than Ultra*Stereo Labs or an authorized service contractor; (B) tampered with or altered in any way or subjected to misuse, negligence or accident or (C) which has been improperly connected, installed or adjusted otherwise than in accordance with Ultra*Stereo Labs instruction. This warranty does not cover damage to surface finishes, normal wear, or failure resulting from abuse.

Table of Contents

Features 4
How It Works 5
Initial Calibration 6
Setup Procedure 7
Microphone Placement 8
Microphone Mounting 9
Low Battery Indicator 9
Remote Switch Circuits 10
Specifications 11



Please record the following information for your records:

Model: _____ Serial Number: _____
Date of Purchase: _____ Purchased from: _____

MMP-10 Features

Four laboratory grade test microphones. ^①

Each microphone is calibrated with its multiplexer to insure utmost accuracy.

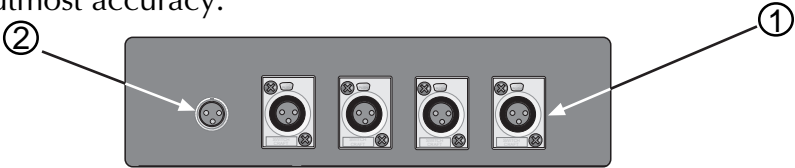

(Top View)

Individual microphone selection or sequential scan.

Adjustable scan rate.

Blinking low battery indicator.

Overall output level adjust.

Works with any audio spectrum analyzer.

Small diameter, lightweight umbilical cable from the multiplexer to your analyzer. ^②

Theater microphone seat mounts included.

Rugged construction.

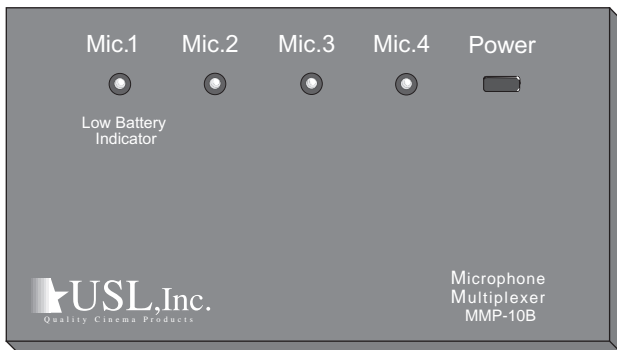

(Front View)

How It Works

The MMP-10 contains four high quality microphone preamplifiers, followed by an adjustable switching circuit. Microphone signals are routed through the unit in several different configurations.

On powerup, only microphone one is amplified and routed through the MMP-10 to your analyzer.

The remote switch at the analyzer end of the MMP-10 cable permits selection of other microphones. Pressing the switch once selects microphone two. Press it again and microphone three is selected; once more and microphone four is selected.

Pressing it once again starts automatic scan mode, which cycles through all four microphones, one at a time. Pressing it one more time resets the MMP-10 to microphone one.

Typical analyzer equipment is shipped with only a single microphone. The MMP-10 allows you to expand your equipment to four microphones. [Such multi-microphone measurement techniques achieve far superior acoustical results in auditoriums due to the averaging effect.]

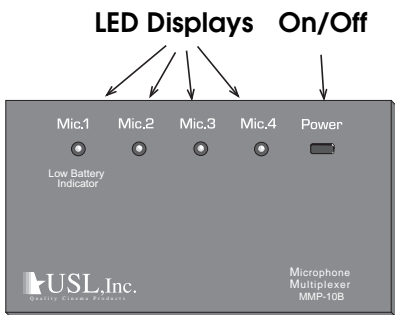

MMP-10 Front

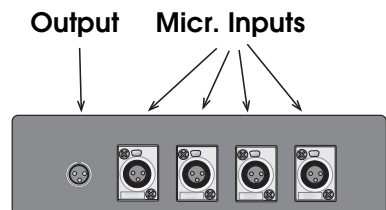

MMP-10 Top

Initial Calibration

The first time you use your new MMP-10, you should set the output level to match the single microphone supplied with your analyzer. To accomplish this find a suitable location and set up your analyzer with its own microphone.

Using pink noise through the sound system, adjust the amplifier level to produce a normal display (85 dbC). Next disconnect the analyzer microphone and connect the MMP-10 (with its four microphones) to the analyzer.

Open the MMP-10 back cover. Select microphone one and adjust the overall potentiometer R# 45 inside the MMP-10 to achieve the same level on your analyzer display as measured with the analyzer microphone. Verify that the remaining three microphones have the same reading.

(Note: it is not necessary to adjust individual trim potentiometers, R10, R20, R30, R40, as these are adjusted at the factory.)

Switch the MMP-10 to scan mode and observe the display of all four microphones. Different analyzers will integrate this switched signal in various ways. Adjust the scan rate potentiometer, R60, to achieve a smooth stable display. If the timing is too slow, the display will bounce.

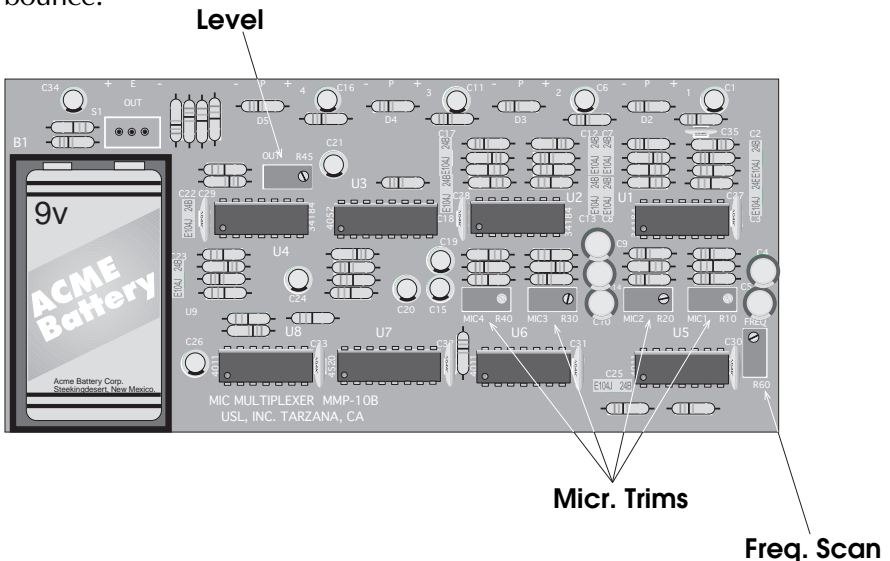

Setup Procedure

Locate the MMP-10 approximately 2/3 back from the screen, off axis of the center speaker, usually between the center speaker and the right speaker to allow for viewing from the booth. Place microphone one at this position. Place the remaining mics. in a diamond pattern within the central area of the room. The microphones should be positioned horizontally with the microphone's screen facing up, toward the ceiling (Figure2). Insert the microphone connectors into the appropriate jacks on the MMP-10.

Connect the audio cable to the MMP-10 and switch the unit on. The red LED for microphone one will be on. Be sure to position the MMP-10 so you can view the LED display from the booth.

Plug the other end (i.e. momentary switch side) of the audio cable into your analyzer up in the projection booth. Switch on Pink Noise. Your MMP-10 wakes up with microphone one selected. Verify you have a signal from microphone one on your analyzer. Select microphone two, three then four to verify operation.

Select multiplex mode (indicated by the LEDs flashing in order: red, green, green green) and set your analyzer to the proper level and commence room equalization.

The multiplexer has been designed to allow for easy room averaging with a small but accurate four microphone multiplexer system. Room equalization using only one microphone is not recommended due to room modes. Using four microphones and MMP-10 multiplexer will allow for the best sound for the greatest number of seats in the room.

Remote control of the MMP-10 is achieved by using a momentary in-line push button located on the audio cable plugged into your analyzer. Pressing the button located on this cable cycles the MMP-10 through five states: Microphone 1, microphone 2, microphone 3, microphone 4 and multiplex (scan) mode.

Ideal Microphone Placement

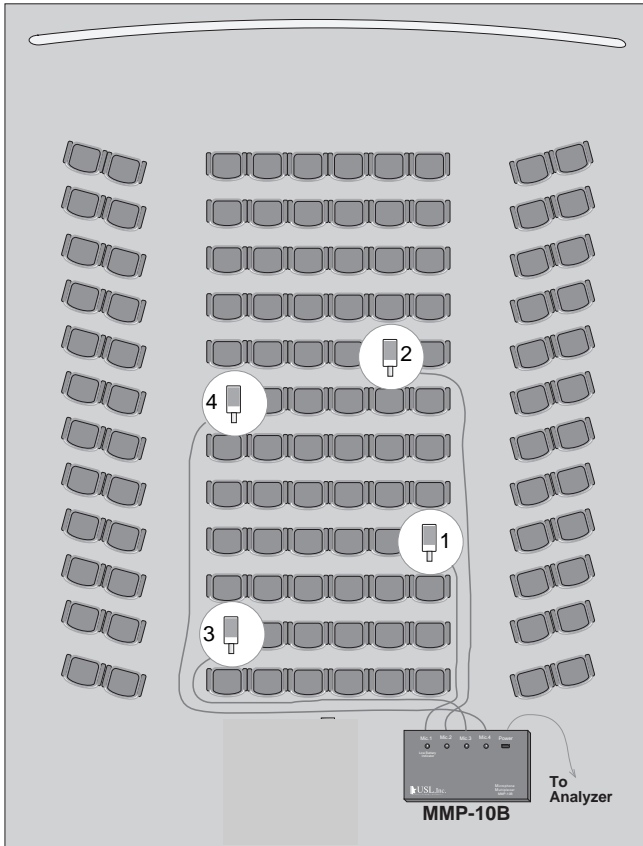

Figure 1

The microphones should be placed in the listening environment as shown above (Figure 1). Variations may apply depending upon size and shape of the auditorium but a diamond formation is best for overall sound field measurement.

Mounting the Microphone

Microphone mounting:

Mount the microphone to the telescoping stand as shown (Figure 2) and place the stands in the desired locations (Figure 3) in the theater or other venue.

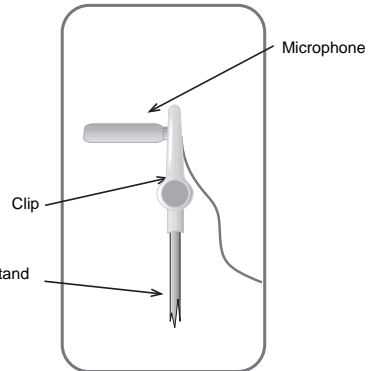

Figure 2

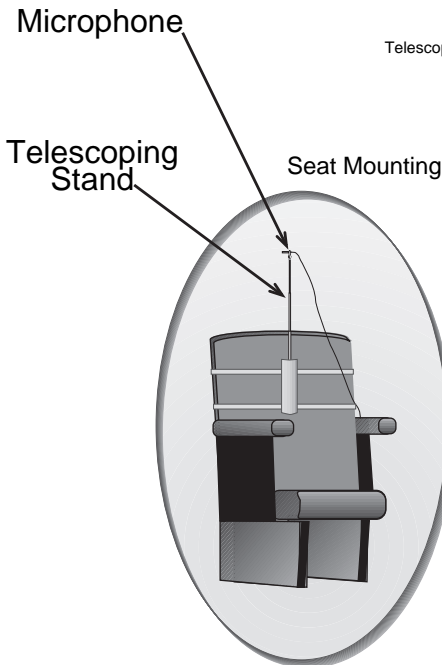

Figure 3

Low Battery Indicator

Low battery voltage can cause the unit to not switch properly, and may cause measurement errors. To avoid this, the MMP-10 incorporates a low battery sensing circuit. When the battery voltage drops too low, the unit will reset to microphone one, and the red LED will blink. Replace the battery with a standard 9V alkaline battery.

Remote Switch Circuits

A 3-pin female cord plug with a momentary on/off switch is a standard item in the MMP-10S kit. This switch cord will work with most balanced input analyzers.

3 PIN SWITCH CIRCUIT

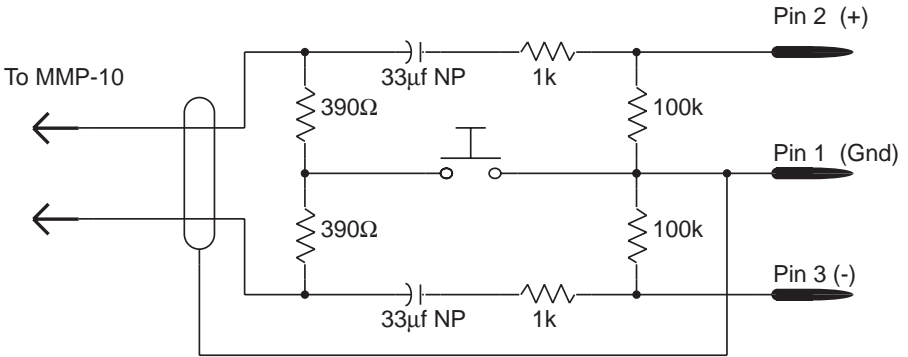

MMP Adapters

The MMP-10 output is a 3-pin female XLR connector. Included is an adapter to a 3-pin male XLR connector (MMP-ADS). Other adapters are available to convert to almost any analyzer or sound processor:

<u>Model #</u>	<u>Connector Type</u>	<u>For Use With</u>
MMP-ADS	3-pin XLR (male)	Audio Control, Gold Line, Abacus ARTA-160, Clark Techniq, HP-8050
MMP-AD1	6-pin XLR (female)	Ivie 30, Ivie PC-40
MMP-AD2	3-pin Mini-XLR (male)	Abacus ARTA-80
MMP-AD5	1/8" Stereo Phone Plug	Dolby CP-500

Specifications

(1K ohm load on each leg of the balanced output)

Nominal microphone input level: -54 dB (2mv)

Maximum output level: -27 dBV (43mV) adjustable

Output impedance: 2K ohms

Number of microphone channels: 4

Individual microphone channel adjustment range: 9dB

Microphone scan rate: 7 to 21 Hz adjustable

Power source: 9 volt battery

Current drain: Approx. 20 ma.

Meets CE Approval Standards

Factory Settings

(1K ohm load on each leg of the balanced output)

Output level: 15mV (-36 dB)

Microphone scan rate: 10Hz

Ultra★Stereo Labs, Inc.
181 Bonetti Drive
San Luis Obispo, CA 93401 USA
Telephone 805.549.0161
FAX 805.549.0163
e-mail usl@uslinc.com

 **USL, Inc.**
Quality Cinema Products
© 1996, 1998 Ultra★Stereo Labs, Inc.
San Luis Obispo, CA, USA.
All Rights Reserved