

Film-Tech

The information contained in this Adobe Acrobat pdf file is provided at your own risk and good judgment.

These manuals are designed to facilitate the exchange of information related to cinema projection and film handling, with no warranties nor obligations from the authors, for qualified field service engineers.

If you are not a qualified technician, please make no adjustments to anything you may read about in these Adobe manual downloads.

www.film-tech.com

LUMINARY 6-4

AUTOMATIC THEATRE INCANDESCENT LIGHTING CONTROL

SPECIFICATIONS

INSTALLATION INFORMATION

OPERATION

WIRING INFORMATION

AUGUST 1989

*LINSEY-FAIRBANKS, INC.
1670 MAYWOOD AVE.
UPLAND, CALIF. 91786-1729
(909) 982-0467*



LINSEY/FAIRBANKS INC. UPLAND, CA. 91786

LUMINARY 6-4 AUTOMATIC THEATRE INCANDESCENT LIGHTING CONTROL

August 1989

MODEL: LFI LUMINARY 6-4

Page 1 of 7

SPECIFICATIONS:

- HOUSE LIGHTS: Complete LUMINARY 4.
- STAGE LIGHTS: As per the following specifications:
- WATTAGE: 2400 watts at 125V AC 60 Hz.
- VOLTAGE: 105V to 132V AC 60 Hz.
- AMPERAGE: 20 amperes.
- DIMENSIONS: 16 inches high - 10 inches wide - 6.5 inches deep.
- WEIGHT: 38 pounds.
- CONSTRUCTION: Two piece back box and hinged cover/chassis. 16 ga. CRS Wall mount.
- CONTROL TYPE: Solid state back-to-back SCR continuously variable firing angle type.
- REMOTE FACILITY (S): All normally open low voltage with pilot functions (24V DC). System interfaces with all popular theatre automation systems.
- CONTROL RANGES:
- | | |
|-------------------|------------------|
| Dim: | 0% to 50%. |
| Half Bright | None. |
| Bright: | 50% to 100%. |
| Dim Rate: | 2 to 60 seconds. |
| Brightening Rate: | 2 to 60 seconds. |
- All adjustments separate and secure from operator tampering.
- INDICATORS: Switch state LED indicators and output bar graph.
- PANIC: None.
- GANG: Up to three (3) LUMINARY 6-4's can be ganged to one set of remotes without accessories to provide effective load control of 12,600 watts, and stage light control of 7,200 watts.
- MULTIPLE INSTALLATIONS: Special design care has been exercised to insure that there is no "cross talk" or cross interference in multiple installations. No special phasing is required. Each unit or channel requires it's own neutral and ground, and complete load isolation is a must.



LINSEY/FAIRBANKS INC. UPLAND, CA. 91786

LUMINARY 6-4 AUTOMATIC THEATRE INCANDESCENT LIGHTING CONTROL

August 1989

MODEL: LFI LUMINARY 4 (HOUSE CHANNEL ONLY)

Page 2 of 7

SPECIFICATIONS:

- WATTAGE: 4200 watts at 125V AC 60 Hz.
- VOLTAGE: 105V to 132V AC 60 Hz.
- AMPERAGE: 34 amperes.
- DIMMENSIONS: 16 inches high - 10 inches wide - 6.5 inches deep.
- WEIGHT: 32 pounds.
- CONSTRUCTION: Two piece back box and hinged cover/chassis. 16 ga. CRS wall mount.
- CONTROL TYPE: Solid state back-to-back SCR continuously variable firing angle type.
- REMOTE FACILITY (S): All normally open low voltage with pilot functions (24V DC). System interfaces with all popular theatre automation systems.
- CONTROL RANGES:
- | | |
|-------------------|---|
| Dim: | 0 to 40%. |
| Half Bright | 30% to 75%. |
| Bright: | 50% to 100%. |
| Dim Rate: | 2 to 60 seconds. |
| Brightening Rate: | 2 to 60 seconds. |
| Manual: | External control to elevate low level only. |
- All adjustments separate and secure from operator tampering.
- INDICATORS: Switch state LED indicators and output bar graph.
- PANIC: The unit is predisposed for a "PANIC" remote, that is, a system to raise the lights to maximum quickly and lock them there in case of emergency required by the National Electric Code.
- GANG: Up to four (4) LUMINARY 4's can be ganged to one remote control without accessories to provide effective load control of 16,800 watts.
- MULTIPLE INSTALLATIONS: Special design care has been exercised to insure that there is no "cross talk" or cross interference in multiple installations. No special phasing is required. Each unit or channel requires its own neutral and ground, and complete load isolation is a must.



LINSEY/FAIRBANKS INC. UPLAND, CA. 91786

LUMINARY 6-4 AUTOMATIC THEATRE INCANDESCENT LIGHTING CONTROL

August 1989

Page 3 of 7

INSTALLATION:

This instruction guide describes the installation of the LUMINARY 6-4 Two Channel Unit. If your unit is a LUMINARY 4 Single Channel Unit, ignore the references to the second or "Stage" channel.

Unpack the system back box which contains the power terminations and the circuit reactors (chokes) and inspect them for damage. Report any damage to your supplying dealer for immediate correction.

We suggest that the unit be installed near the projection room distribution panel and away from the theatre sound system and other SCR control devices, such as film transports. The unit should be mounted at approximately eye level. Connect conduits as required, see drawing below.

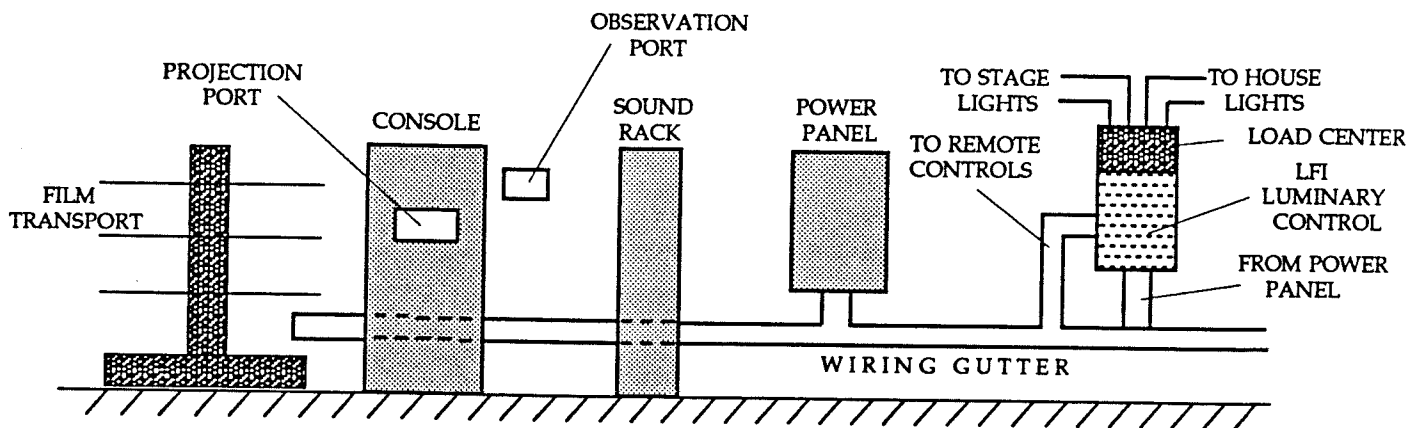

After the back box unit is installed and all of the power and load lines are pulled in and terminated per drawing D5004925, and the remote control lines are pulled in, unpack the cover/chassis unit and install per drawing number D5004925. Connect the interface wiring between the back box and the chassis, and terminate the remote control (s) in accordance with the *LUMINARY 6-4 SYSTEM WIRING DIAGRAM AUTOMATIC THEATRE INCANDESCENT LIGHTING CONTROLS*.

THE LOAD CENTER

The Load Centers are very important for the safety of the public and the equipment. The house light channel operating at full capacity (4200 watts) must be protected with a service breaker of 50 amperes. If no Load Center is installed to break up the load into 15 ampere increments, a load short must exceed 50 amperes in order to trip the service breaker. This not only WILL DAMAGE THE SCR SWITCHING MODULE, BUT COULD ALSO START A LAMP FIXTURE FIRE.



LINSEY/FAIRBANKS INC. UPLAND, CA. 91786

LUMINARY 6-4 AUTOMATIC THEATRE INCANDESCENT LIGHTING CONTROL

August 1989

Page 4 of 7

INSTALLATION:

PREVENTING SCR SWITCHING CROSS TALK AND LINE NOISE.

Please note on drawing number D5004925 that a SEPARATE neutral is pulled for each dimmer channel. This eliminates the possibility of common or neutral feedback, a common cause of SCR cross talk. Note further that a technical or "Cold Water" ground is also required. It is strongly recommend that these procedures be used for all SCR control devices in the installation.

NOTE : Temporarily connect the lighting loads directly to the line and test for shorts before connecting the dimmer.

SETTING THE LEVELS AND SPEEDS:

Note 1: Find House Channel trimmer controls R12 through R16, just above group of six relays near bottom of Main Circuit Board.

Note 2: Similarly, find Stage Channel trimmer controls R4, R5, R24 and R25 above the two relays near top of main circuit board.

Note 3: Before beginning turn all control trimmers fully clockwise (CW)

HOUSE LIGHTS

1. Apply power. The two yellow LEDs will light and both loads will turn full ON. Switch the Stage Lights to "DIM", the Stage red LED will light and the Stage Lights will dim to OFF.
2. Adjust the HOUSE BRIGHT trimmer to a comfortable intermission illumination level.
3. Switch the House Lights to "DIM", the House red LED will light and the house lights will dim to OFF. Adjust the HOUSE DIM trimmer counterclockwise (CCW) to a level just high enough to see the seats.
4. Switch the House Lights to Half Light. The green LED will light. Adjust the HALF LIGHT trimmer to a level just high enough to see color in the auditorium.
5. Adjust the speeds by alternating between dim and bright as you adjust the SPEED trimmers. Adjust speeds to desired rate



LINSEY/FAIRBANKS INC. UPLAND, CA. 91786

LUMINARY 6-4 AUTOMATIC THEATRE INCANDESCENT LIGHTING CONTROL

August 1989

INSTALLATION:

Page 5 of 7

STAGE LIGHTS

1. Switch both House and Stage lights to BRIGHT. Both yellow LEDs will light. Adjust STAGE BRIGHT trimmer to desired intermission illumination level.
2. Switch both House and Stage lights to dim. Both red LEDs will light. Adjust the STAGE DIM trimmer so that the stage lights are OFF, or if the stage channel is used for low voltage aisle or step lighting set at a low but visible level.
3. Set speeds the same as for the House lights using STAGE LIGHTS SPEED trimmers.

GANGING UNITS;

In larger installations where lighting loads exceed 4200 watts, up to three (3) units can be "ganged" together increasing control capacity of 12,600 watts for House Lights, and 7200 watts for the Stage lights.

WARRANTY:

All LFI products carry a one (1) year warranty from the date of purchase against defects resulting in material or workmanship. Contact LFI for details.

ACCESSORIES:

A complete line of accessories including remote controls and load distribution centers are available.

SPECIAL AND CUSTOM SYSTEMS:

Custom systems and special features are available on request. Contact LFI for quotations.



LINSEY/FAIRBANKS INC. UPLAND, CA. 91786

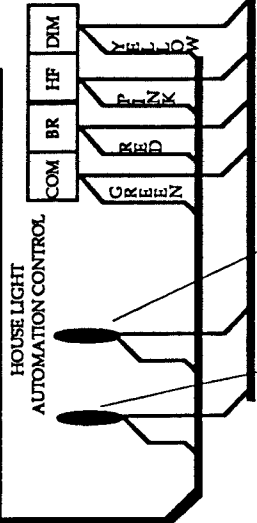
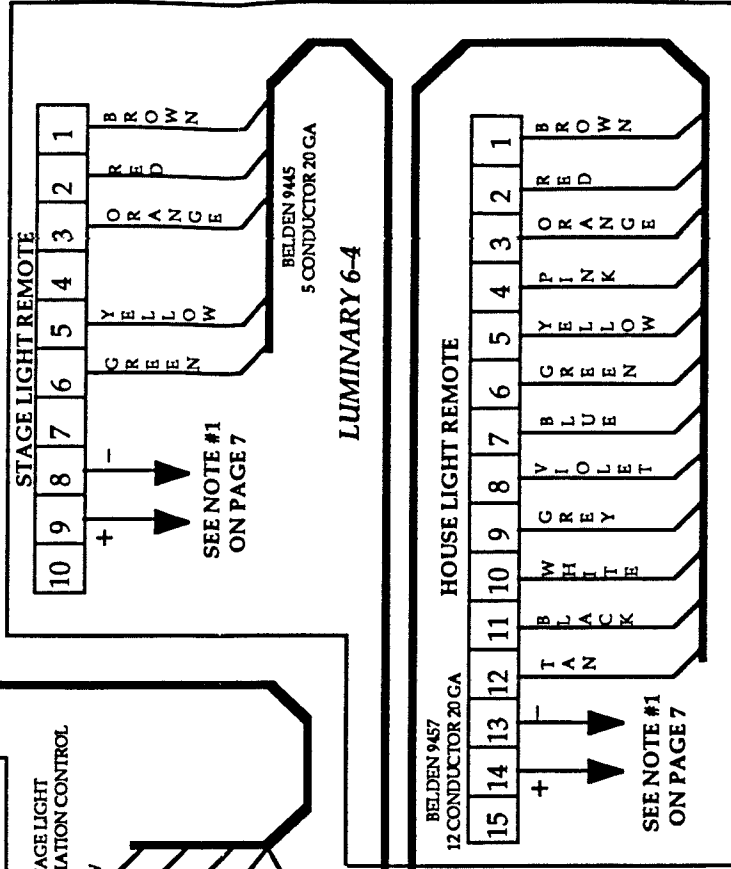
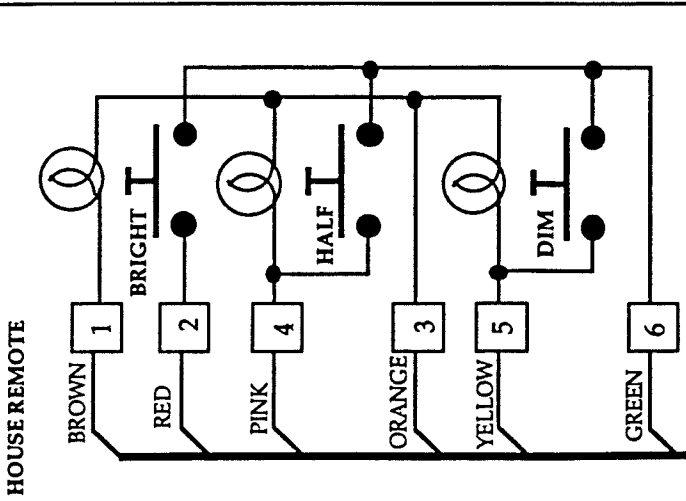
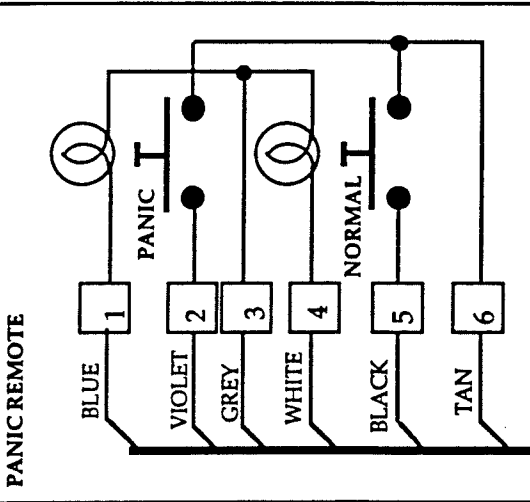
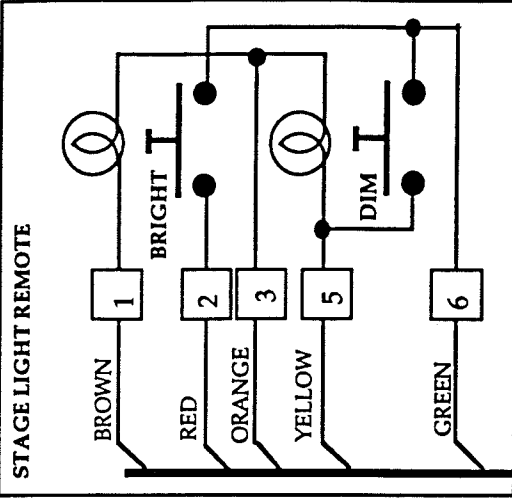

SPLICE ORANGE TO ORANGE

SPLICE BROWN TO BROWN

SPLICE ORANGE TO ORANGE

SPLICE BROWN TO BROWN

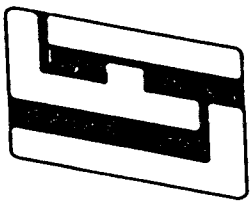

NOTES FOR WIRING DIAGRAM ON PAGE 6

- #1. TO WIRE UP TO THREE (3) LUMINARY 6-4 AUTOMATIC THEATRE INCANDESCENT LIGHTING CONTROLS IN PARALLEL CONNECT ALL TERMINAL #8'S TOGETHER AND ALL TERMINAL 9'S TOGETHER BETWEEN STAGE LIGHT REMOTE TERMINAL BLOCKS. ALSO CONNECT ALL TERMINAL #13'S TOGETHER AND ALL TERMINAL 14'S TOGETHER BETWEEN HOUSE LIGHT REMOTE TERMINAL BLOCKS.
- #2. FOR MULTIPLE HOUSE CHANNELS: PARALLEL WIRE TERMINALS 1 THROUGH 6 ON CONNECTOR BLOCK E1.
- #3. FOR MULTIPLE STAGE CHANNELS: PARALLEL WIRE TERMINALS 1, 2, 3, 5, AND 6 ON CONNECTOR BLOCK E2.
- #4. FOR MULTIPLE PANIC REMOTES: PARALLEL WIRE TERMINALS 7 THROUGH 12 ON CONNECTOR BLOCK E1.
- #5. ALL MULTIPLE WIRING IS 24V DC
- #6. ALSO REMOVE THE J1 AND THE J2 FUSES ON ALL OF THE ADDITIONAL LUMINARY 6-4 AUTOMATIC THEATRE INCANDESCENT LIGHTING CONTROLS THAT ARE WIRED IN PARALLEL WITH THE FIRST UNIT.
- #7. ALL PILOT LAMP CIRCUITS ARE 24 VDC, AS ARE ALL CONTROL LOOPS.
- #8. ALL AUTOMATION SWITCHING MUST BE NORMALLY OPEN (N.O.) MOMENTARY DRY CONTACTS.
- #9. REMOTE CONTROL TERMINAL BLOCKS PLUG INTO SOCKETS. FOR EASE OF TERMINATION, UNPLUG TO CONNECT WIRES.

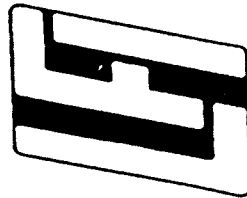

LUMINARY 6-4
SYSTEM WIRING DIAGRAM
AUTOMATIC THEATRE
INCANDESCENT LIGHTING CONTROL

LINSEY/FAIRBANKS INC. UPLAND, CA. 91786

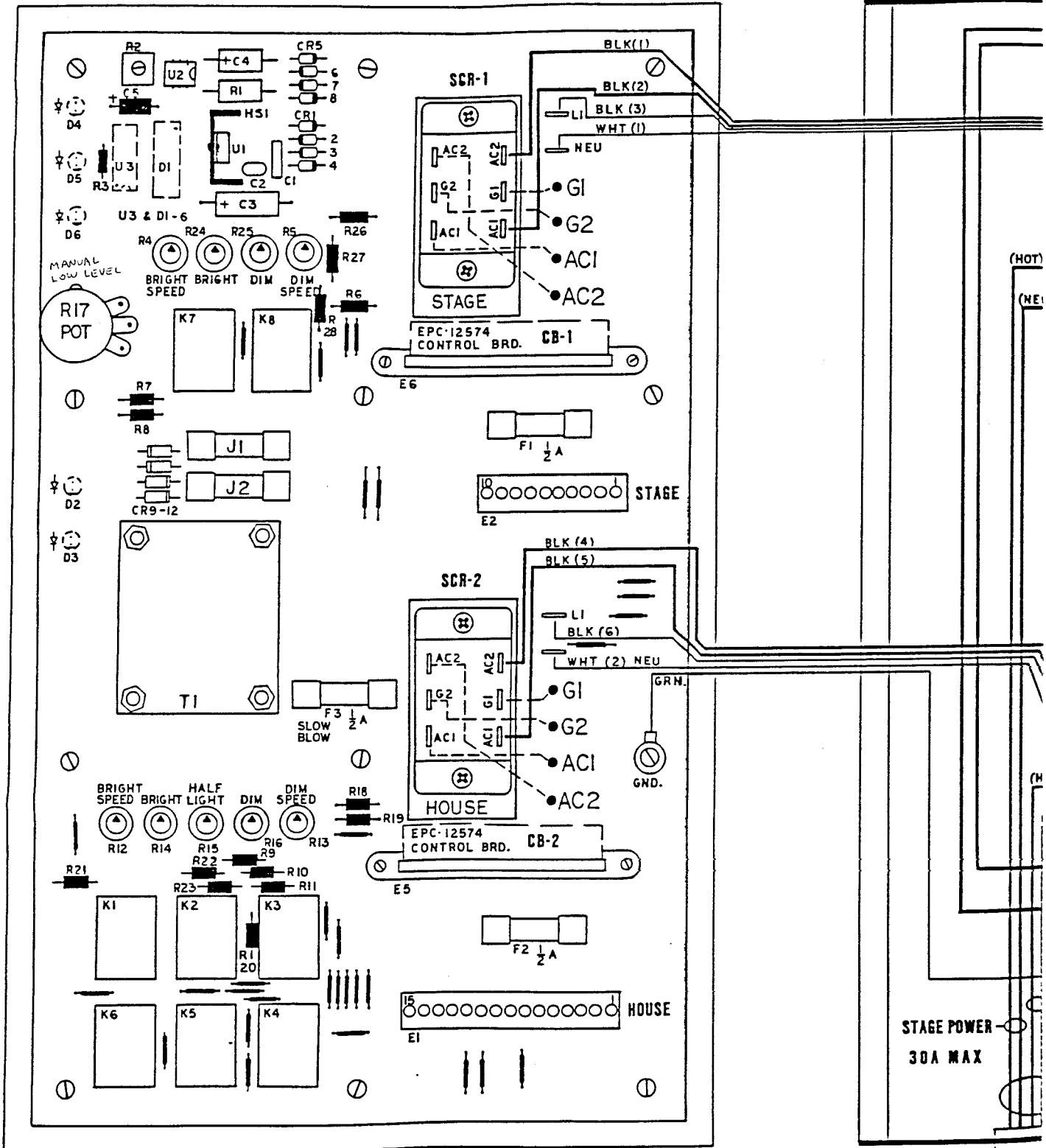

INSIDE FRONT COVER

EXTERNAL WIRING / FOR REFERENCE ONLY

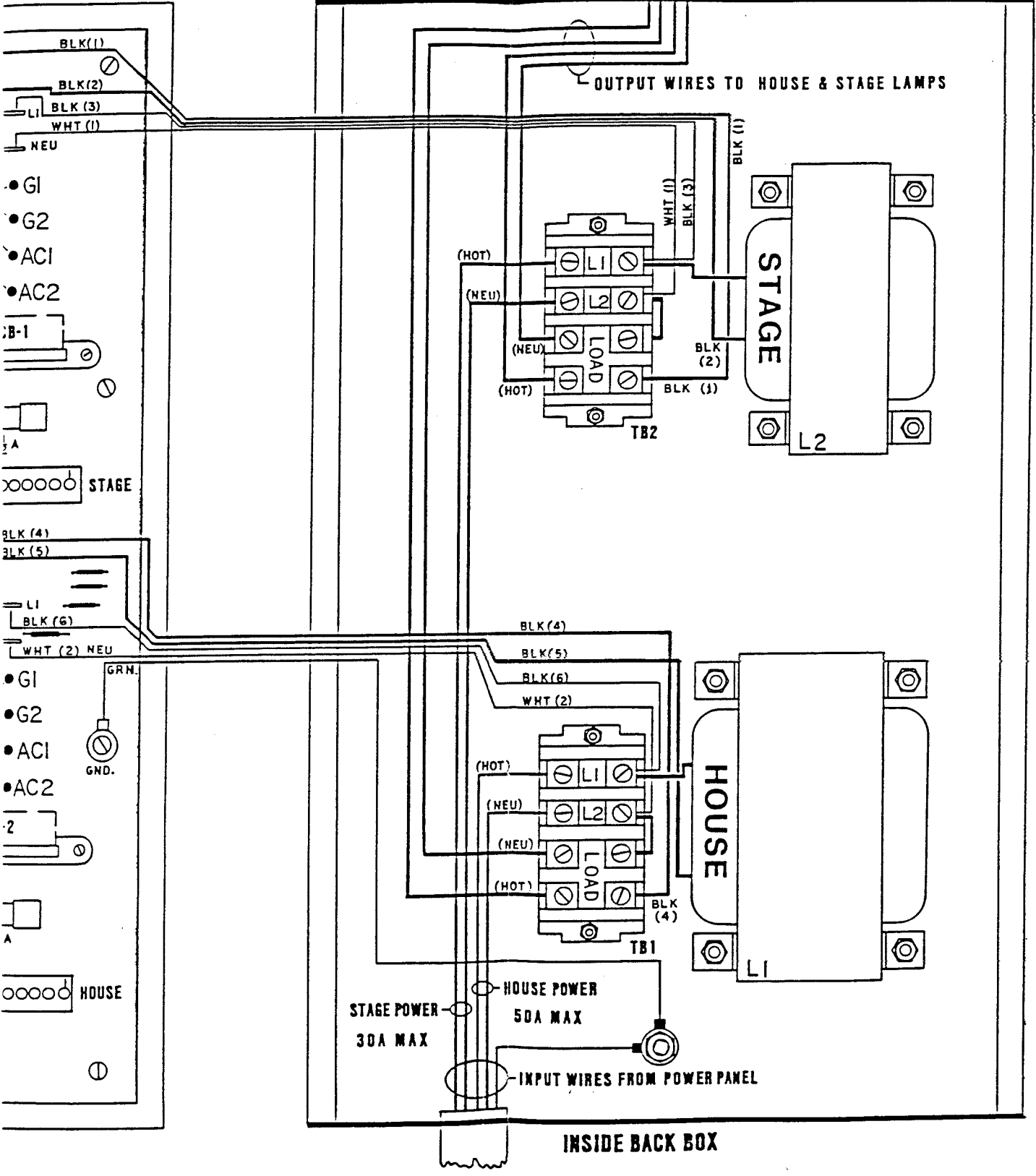
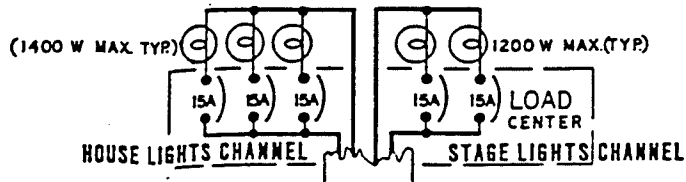

L
D
E
F
F
J
K
K
K
K
K
K
K
K
R
R
R
R
R
R
R
R
R
R
S
S
S
C
E
E
E
E
E

INSIDE BACK BOX

C

ONLY

30 W MAX.(TYP)

LOAD
ENTER
LIGHTS CHANNEL

FUSE & STAGE LAMPS

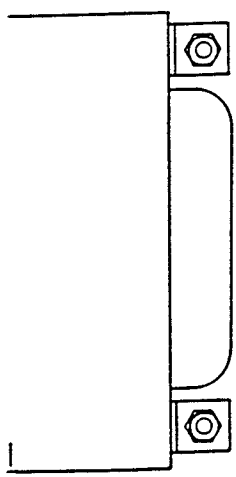
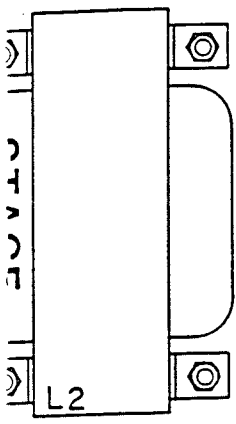

LEGEND - PART IDENTIFICATION

IDENT.	DESCRIPTION	USE ASSOCIATION
F1	FUSE 1/2A FAST BLOW	STAGE CONTROL
F2	FUSE 1/2A FAST BLOW	HOUSE CONTROL
F3	FUSE 1/2A SLOW BLOW	CONTROL XFMR
J1	JUMPER } REMOVE JUMPERS	MULTI-UNIT HOOK-UP
J2	JUMPER } FOR MULTI-UNIT HOOK-UP	MULTI-UNIT HOOK-UP
K1	RELAY 4PDT	HOUSE BRIGHT
K2	RELAY 4PDT	TRANSFER
K3	RELAY 4PDT	HOUSE HALF LIGHT
K4	RELAY 4PDT	HOUSE DIM
K5	RELAY 4PDT	HOUSE PANIC
K6	RELAY 4PDT	HOUSE NORMAL
K7	RELAY 4PDT	STAGE BRIGHT
K8	RELAY 4PDT	STAGE DIM
K9	POTENTIOMETER	HOUSE LOW LEVEL MAN.
R4	TRIM-POT	BRIGHT SPEED (stage)
R24	TRIM-POT	BRIGHT LEVEL (stage)
R5	TRIM-POT	DIM SPEED (stage)
R25	TRIM-POT	DIM LEVEL (stage)
R12	TRIM-POT	BRIGHT SPEED (house)
R13	TRIM-POT	DIM SPEED (house)
R14	TRIM-POT	BRIGHT LEVEL (house)
R15	TRIM-POT	HALF LIGHT LEVEL(house)
R16	TRIM-POT	DIM LEVEL (house)
SCR-1	SCR-MODULE	STAGE
SCR-2	SCR-MODULE	HOUSE
CB-1	CONTROL BRD.	STAGE
CB-2	CONTROL BRD.	HOUSE
E2	TERM.BLK. (REMOTE)	STAGE
E1	TERM.BLK. (REMOTE)	HOUSE

LUMINARY 6-4
 AUTOMATIC THEATRE
 INCANDESCENT LIGHTING CONTROL
 LINSEY/FAIRBANKS INC. UPLAND, CA. 91786

DWG. NO. D5004925