

FILM-TECH

THE INFORMATION CONTAINED IN THIS ADOBE ACROBAT PDF FILE IS PROVIDED AT YOUR OWN RISK AND GOOD JUDGMENT.

THESE MANUALS ARE DESIGNED TO FACILITATE THE EXCHANGE OF INFORMATION RELATED TO CINEMA PROJECTION AND FILM HANDLING, WITH NO WARRANTIES NOR OBLIGATIONS FROM THE AUTHORS, FOR QUALIFIED FIELD SERVICE ENGINEERS.

IF YOU ARE NOT A QUALIFIED TECHNICIAN, PLEASE MAKE NO ADJUSTMENTS TO ANYTHING YOU MAY READ ABOUT IN THESE ADOBE MANUAL DOWNLOADS.

WWW.FILM-TECH.COM



PLAINVILLE, CONNECTICUT 06062

DATE Dec. 1981
NUMBER 90-23 -A

SERVICE BULLETIN

INDEX PREVENTIVE MAINTENANCE (REVISED)

Attached is a program of various operations which should be completed during the course of repairing any Model 90 projector. Following this program will help eliminate future problems thus decreasing the down time of projectors in the field.

When the projector is first inspected, the customer's comments should be verified. If you are unable to duplicate the problem, contact the customer for a more detailed explanation of the problem, as there are times when a customer is not fully versed on projector terminology.

After the customer's original complaint is identified and resolved, then the attached program should be faithfully followed. The entire program takes approximately half an hour. This half an hour will be well worth a satisfied customer.

NOTE: For additional information, refer to the Series 90 Service Manual Form No. 2811-A.

REMOVE REAR COVER AND CHECK THE FOLLOWING:

A. Oscillator shaft end play.

PROBLEM: Excessive end play will cause shuttle to go in and out during operation causing loss of loop and continual revolving of loop setter.

REMEDY: Loosen two (2) set screws on worm gear (A). Place a screwdriver at end of oscillator shaft Point (B) to hold shaft in place. Insert allen wrench in one (1) set screw in worm gear and push lightly against collar and tighten both set screws.

FIG. 1

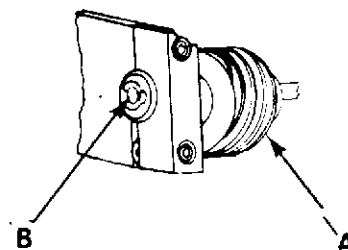

B. Gate Lever operation.

PROBLEM: Improper operation of Gate Lever will not set the required loops causing projector to shut off upon turning the Control Knob.

REMEDY: Raise Gate Lever to full open position. Lower Gate Lever slowly until rear shoe closes. Check lower loop setter to see if it can be released very easily by lifting it with finger. (Refer to Fig. 2). It should be firmly in position. If it releases by applying a slight pressure, press lever (A) Fig. 3 in towards casting slightly so that lever will be seated properly on catch (B). Continue to lower Gate Lever slowly until lower loop releases then press on top loop setter to be sure it is securely seated.

FIG. 2

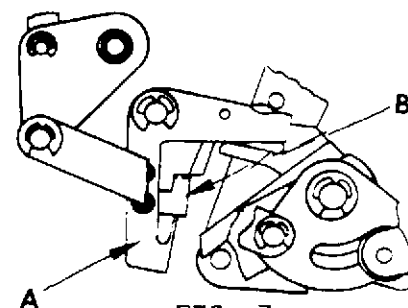
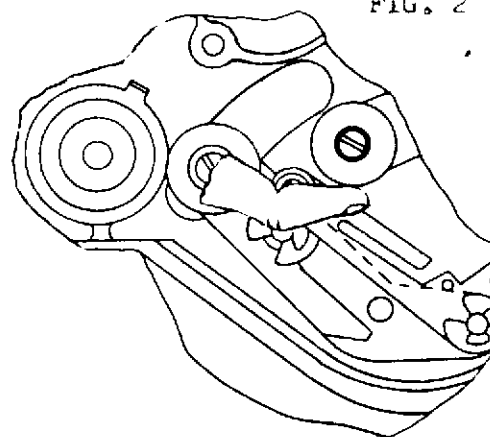

FIG. 3

C. Bearing at end of Oscillator Shaft.

PROBLEM: Loose bearing will cause excessive shuttle protrusion.

REMEDY: Tighten top screw (A) securely. Tighten screw (B) just tight enough so that the bearing will not move. Do not overtighten. The best method to check this is to insert shuttle adjustment wrench at point (C), and with excessive pressure the bearing should not move. If it does, tighten Screw (B) until the bearing doesn't move. (Refer to Fig. 4)

CAUTION: Excessive tightening will cause the mechanism to bind and run unevenly.

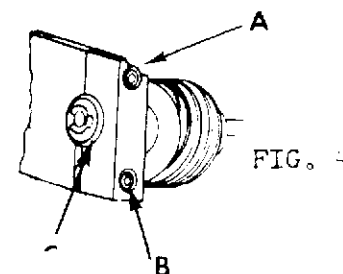

FIG. 4

D. Check Pinch Roll pressure.
PROBLEM: Garbled sound.

REMEDY:

1. Rotate Control Knob to Forward operating position. There should be approximately 1/8" clearance between Pinch Roller Arm Assembly and stud on Pinch Roller Actuating arm. (Refer to Fig. 5)
2. If you do not have this clearance, perform the following:
 - A) If serial number of projector is below 920-6587, replace Cam Bearing Assembly behind Control Knob. (Refer to Fig. 6)
 - B) To adjust, loosen screw (A) Fig. 7. Rotate excentric (B) counterclockwise approximately 1/4 turn. Secure screw (A).
 - C) Control Knob may be loose. Tighten. There should be a slight amount of forward motion of Control Knob after knob is in Forward position. If not, remove knob and file about 1/4 off of extrusion on knob. (Refer to Fig. 8)

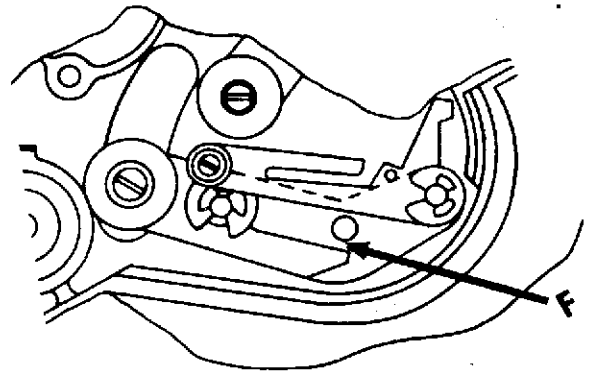

FIG. 5



FIG. 6
(#53485-A)

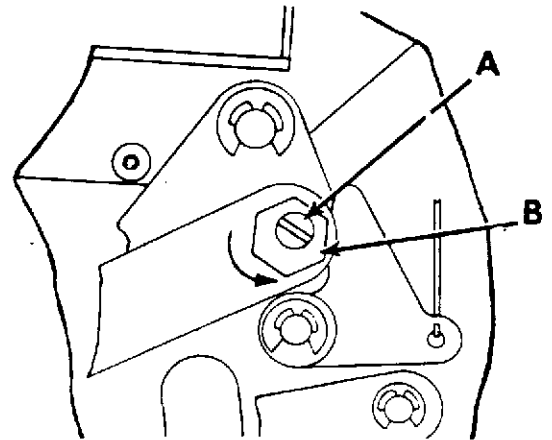

FIG. 7

E. Check Shuttle Protrusion

PROBLEM: Excessive or insufficient shuttle protrusion will cause continual revolving of lower loop setter.

- REMEDY:
1. Loosen set screws (A) and (B) Fig. 9.
 2. Rotate hex end of bearing at point (C) clockwise to decrease protrusion; counterclockwise to increase protrusion. (Use shuttle wrench 53529)

Note: By observing the shuttle teeth, they should retract just below the film channel. Refer to Fig. 10. Setting the shuttle in this manner will allow the shuttle to protrude approximately 1/16" when it advances the film. (Refer to Fig. 11)

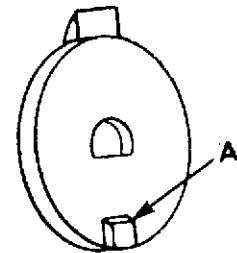

FIG. 8

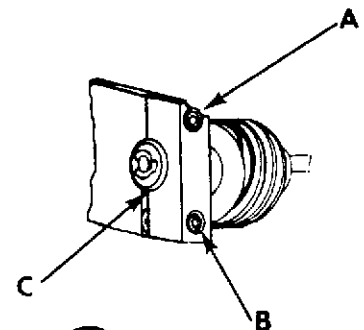

FIG. 9



FIG. 10



FIG. 11

F. Rear Shoe

PROBLEM: Film slipping through Rear Shoe causing Top Loop Setter Switch to activate turning off projector.

- REMEDY:**
1. Thread projector and close gate.
 2. Loosen screw (A).
 3. Rotate excentric (B) clock-wise which will raise latching lever (C).
 4. Latching lever (C) should just touch top on notch on shoe bracket at point (D) and then tighten screw (A) securely.
 5. Raise Gate Lever to full open position.
 6. Rotate Control Knob to Forward position and while projector is running film, manually move latch lever to left and then release. It should just clear top of notch at point (D) without binding.

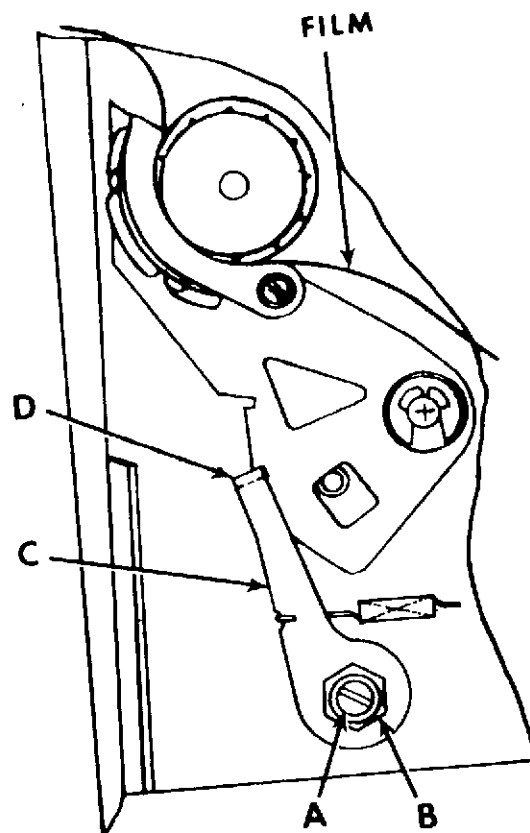

FIG. 12

G. Reel Arms

PROBLEM: Will not take-up 2,000 ft. of film. Rewinds very slowly or will not rewind at all.

- REMEDY:**
1. Starting with serial number 920-9103; we installed oilite reel arm bearings for long life. If projector is below this serial number, the bearings on both reel arms should be replaced with new oilite bearings.
 #53575-A2 End Pulley, Take-up
 #53612-3A Supply Spindle Ass'y
 2. Starting with serial number 921-1652, the Supply Spindle hub was pinned to the bearing. If projector is below this serial number, replace with new pinned Supply Spindle. (Refer to Fig. 13) #53612-3A Supply Spindle Ass'y
 3. Starting with serial number 921-2015 we began installing Take-up Spindles with new cork dimensions to extend the life of the spindles. If projector is below this serial number, replace Take-up Spindle.
 #53612-A1 Take-up Spindle Ass'y

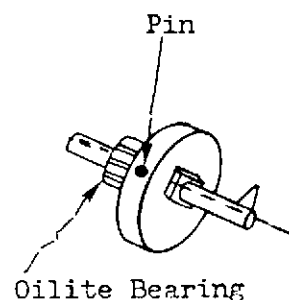

FIG. 13

H. Check Lower Loop Setter Roller

PROBLEM: Film not always seating in Film Channel properly causing film to slip by and loop setter to continually revolve.

REMEDY: Replace roller if it is as shown in Fig. 14 with Roller as shown in Fig. 15.

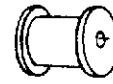
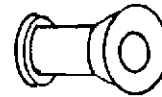

FIG. 14



#53246-3

FIG. 15

I. Sound Lens Assembly

PROBLEM: Muffled sound. Low volume.

REMEDY: Remove foreign material from Sound Lens using a pipe cleaner dipped in alcohol. Insert the pipe cleaner between the Sound Drum and the Sound Lens at Point A. Clean the glass disc covering the top of the Sound Lens, Point B.

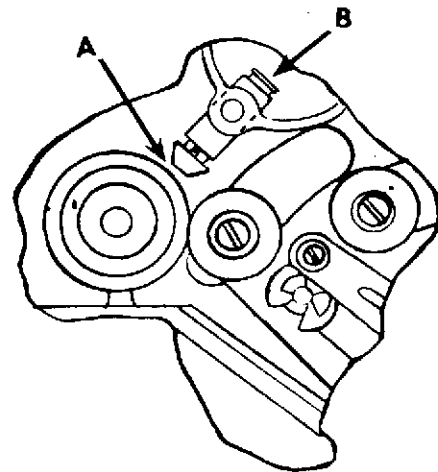

FIG. 16

J. Lubrication of Take-up Spindle

PROBLEM: Excessive tork on take-up.

REMEDY: Remove spindle from Take-up Arm. Apply special lubrication S111-13 on cork. Refer to Fig. 17. (note: we began using this new lubrication on projector serial No. 921-4358)

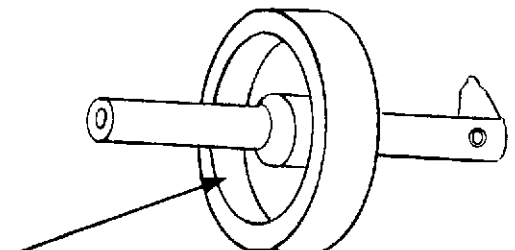

FIG. 17



K. Lamp Replacement Designation

PROBLEM: Incorrect exciter lamp causing low volume.

REMEDY: Place on the exciter lamp shield the self-adhesive sticker #53925. Refer to Figs. 18 & 19.

REPLACEMENT LAMP
EJL OR ELC
EXCITER LAMP
1 AMP 6 VOLT
A S A CODE BSS

FIG. 18

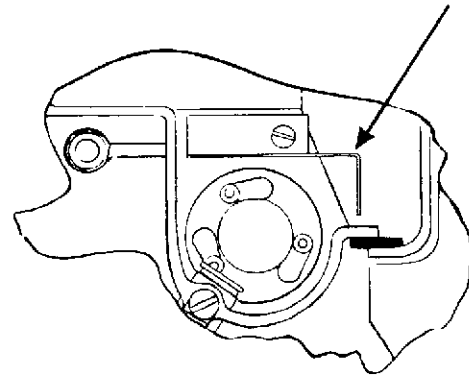

FIG. 19

L. Sound Lens Film Guide

PROBLEM: Film lays against sound lens causing no sound.

REMEDY: Install Film Guide #53924 using screw #S254-832-3. Refer to Fig. 20. (note: we began installing this film guide with projector serial No. 921-3819)

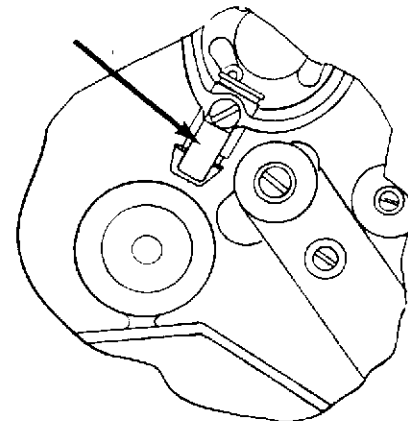

FIG. 20

M. Oil Seepage onto Sound Lens.

PROBLEM: Muffled and low volume.

REMEDY: Place a strip of felt onto casting as illustrated in Fig. 21. (note: this began with projector serial No. 921-4105)
#54172 Felt Strip

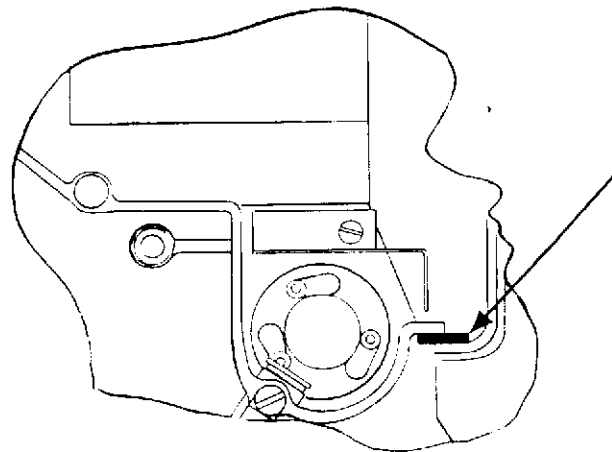

FIG. 21