

FILM-TECH

THE INFORMATION CONTAINED IN THIS ADOBE ACROBAT PDF FILE IS PROVIDED AT YOUR OWN RISK AND GOOD JUDGMENT.

THESE MANUALS ARE DESIGNED TO FACILITATE THE EXCHANGE OF INFORMATION RELATED TO CINEMA PROJECTION AND FILM HANDLING, WITH NO WARRANTIES NOR OBLIGATIONS FROM THE AUTHORS, FOR QUALIFIED FIELD SERVICE ENGINEERS.

IF YOU ARE NOT A QUALIFIED TECHNICIAN, PLEASE MAKE NO ADJUSTMENTS TO ANYTHING YOU MAY READ ABOUT IN THESE ADOBE MANUAL DOWNLOADS.

WWW.FILM-TECH.COM

Electronic power supply

EX-200GM3

INSTALLATION AND OPERATION MANUAL

MAN01524E/2

Caution !

You should read this manual before attempting any intervention inside the unit.

The noncompliance with the instructions given in this manual can lead to serious damage to the unit which in this case will invalidate the warranty.

No compensation or indemnity under any kind will be acknowledged for injury or damage due to use or misuse of the product, for poor operation of the appliances connected to IREM product or for immediate or indirect damage caused to the powered equipment.

During the warranty period the replacement of defective parts and maintenance procedures will be exclusively carried out at IREM servicing centre.

Keep this manual along with the unit.

EX-200GM3

Description

This electronic power supply for three phase 208 and 400Vac 50/60Hz input, has been designed to feed from 3600 to 10000W short arc Xenon lamps, meeting all the requirements of lamp manufacturers to ensure correct operation, long life to the lamp, and high reliability.

This compact and lightweight power supply has been designed to meet the requirements of a unit to be installed inside a cabinet.

Its particularly compact design, the advanced circuitry and the displacement of input and output terminal board and the lamp current adjustment make the unit suitable to a wide variety of applications both in vertical and horizontal position and specifically:

- film projection (traditional and digital applications)
- theatre applications
- architectural applications
- solar simulations.

The main characteristics of this power supply are:

- digital setting of parameters and operation modes,
- internal control of the delivered power
- two hour meters (total and partial)
- RS232 communication interface

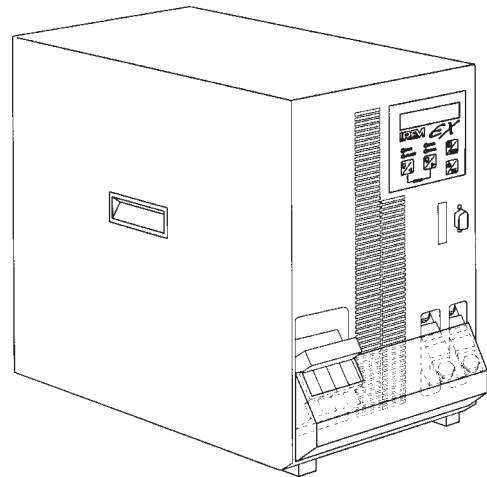
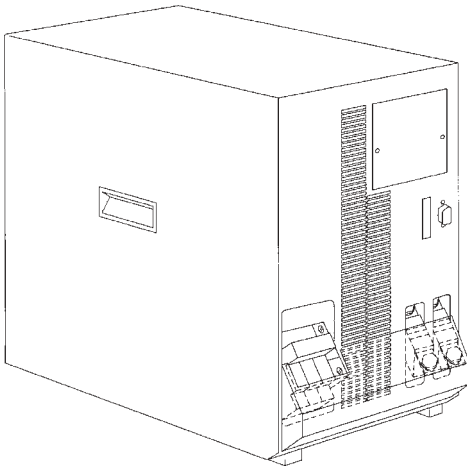

EX-200GM3 electronic power supply may be fitted, on request, with a synoptic panel displaying the main operating parameters of the unit. The pictures and the instructions of this manual are referred to a unit fitted with such a device.

Block diagram

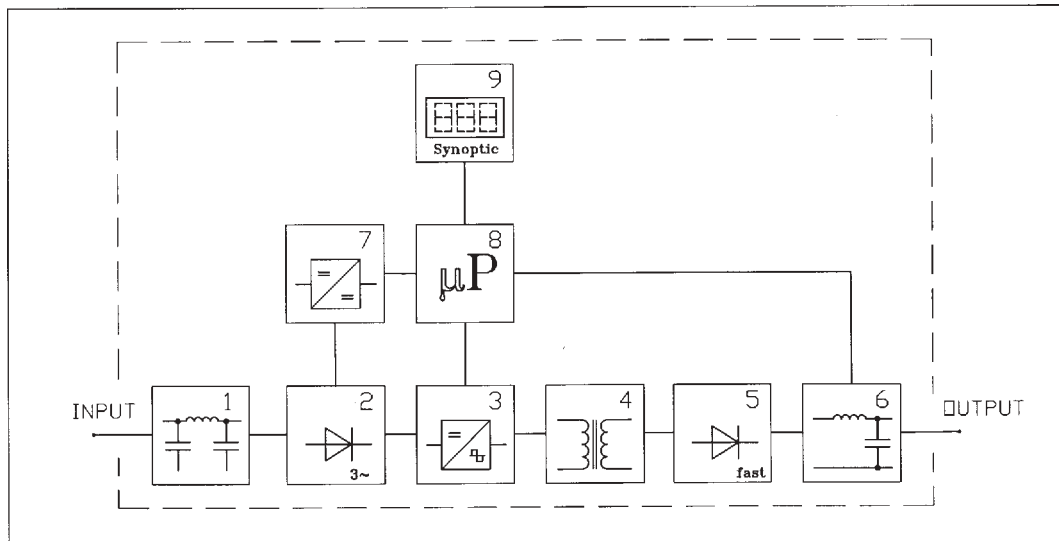

1. Input filter board

Limiting the high frequency interferences (complying with EMI/EEC Standards).

2. Diode bridge rectifier

Converting the alternated voltage from the mains into direct voltage

3. Inverter board

Designed in compliance with IGBT technology, H type full bridge configuration

4. High frequency transformer

Ensuring the galvanic insulation between input and output

5. Output rectifier circuit

Composed by two fast low noise diodes

6. Output filter

Ensuring the lamp ripple current value at $\leq 1\%$ pk- pk.

7. Auxiliary powering board

8. μ p board and controls

9. Synoptic board (on request)

EX-200GM3

Technical characteristics

	EX-200GM/3-E	EX-200GM3-US	
Ordering code	400V version 00832031	208V version 00832036	
Lamp capacity [W]	3600 to 10000		
Input voltage range [V]	360-460 3ph	187-230 3ph	
Input frequency [Hz]	50/60		
Max. input current [A]	23	36	
Sinusoidal absorption	not provided		
DC output current range [A]	80-210		
DC voltage range [V]	30-58		
DC max. output voltage at 170A [V]	47.6		
Max. output power [W]	10800		
No-load voltage range [V]	145-185		
No-load voltage rising time [s]	3		
Ripple [%]	<1		
Efficiency	0.9		
Output overload protection	electronic		
Lamp striking	soft-start ignition current		
Input circuit protection	fuse	breaker	
Input extra voltage protection	provided		
Serial line protection*	<i>optoisolator</i>		
Output current stabilisation	provided		
Synoptic panel**	<i>LCD displaying: current, rated power, voltage unit internal temperature, operation hours (in total) operation hours (for each lamp) keyboard, external switch, serial line keyboard, 0-10V signal, serial line</i>		
ON/OFF control	RS232 serial line - baud rate: 19200, parity: none		
Lamp current adjustment	data bit: 8, communication protocol: IREM		
Remote control	lamp ON, alarms ON		
Output signals	0-10V signal, emergency, ON/OFF remote		
Input signals	stand-by mode		
Operating temperature [°C]	0 to +40		
Storage temperature [°C]	-20 to +60		
Degree of protection	IP10		
Markings	CE	UL	
Insulation class	CL1		
Ventilation	forced		
Dimensions [mm]	255x465x420h		
Weight [kg]	33		

* on request for both versions

** on request for both versions

Functions and controls

Control devices

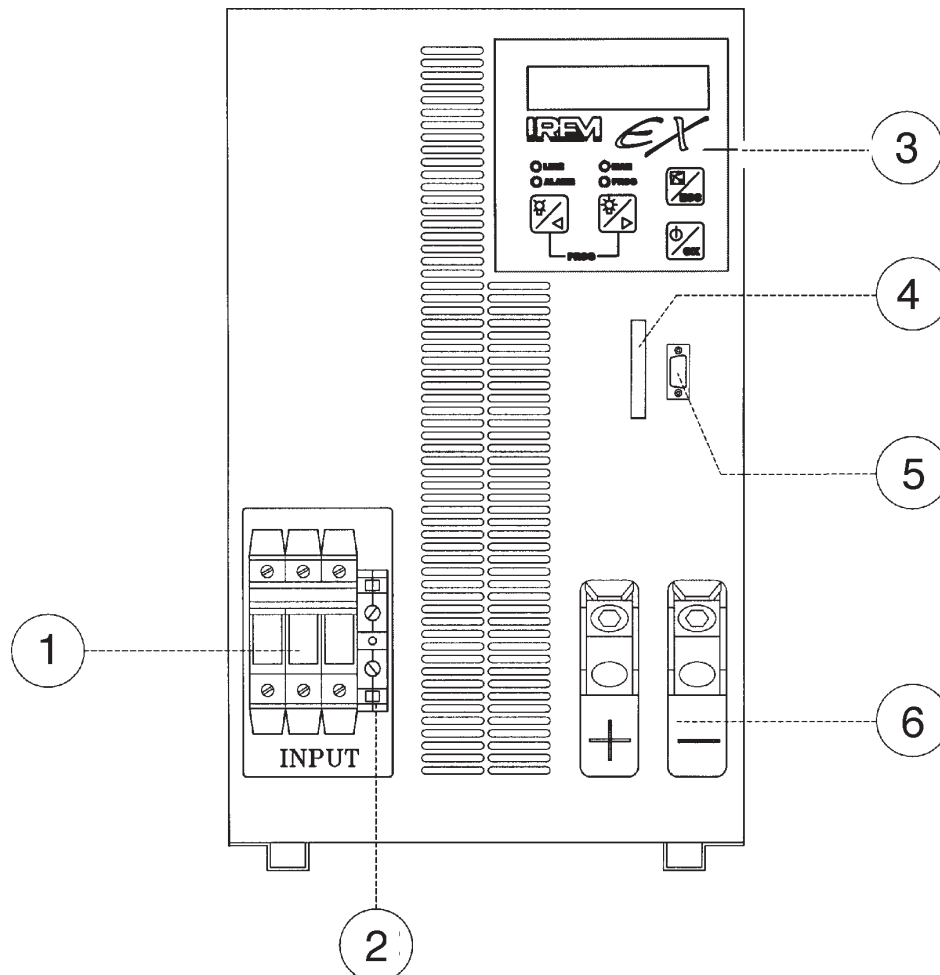

1. Input circuit protection
2. Ground terminal
3. Synoptic panel (on request)
4. Auxiliary terminal board
5. RS232 connector
6. Output terminal board

Connection and operating information

Receiving the equipment

After receipt, check that the unit is in good condition. When necessary, contact the forwarding agent.

Delivery arrangement

The supply consists of:

EX-200GM3... electronic power supply
plate for terminal protection
metal brackets
three spare fuses
serial line optocoupler + adapter 9/25 pin (on request)
synoptic panel (on request)
auxiliary connector
installation and operation manual
warranty card.

Storage

If the unit is stored before installation, check that it is kept dry and cannot come into contact with water in any form. Do not expose the unit to the sun rays or other sources of heat.

Package removing and handling

Remove the packing and keep it in case of future transportation needs. Carefully lift the unit by means of its handles. Avoid any shock when moving.

Installation - environment

The performance of the **EX-200GM3...** electronic power supply is guaranteed for a temperature range variable between 0°C and +40°C. Check that the place where the equipment is to be installed is sufficiently ventilated to prevent the air around the unit from exceeding this limit. Avoid dusty environments.

Ensure that the ventilation slots are unobstructed.

To prevent blockages caused by excessive temperatures, do not expose the unit to the sun rays or other sources of heat.

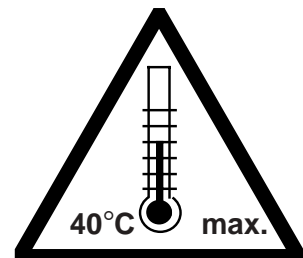

Connection and operating information

Warnings

Caution: dangerous voltage inside the power supply. Disconnect the unit from the mains before checking the internal components.

Prevent water, liquids in general and/or foreign objects from getting inside the appliance (do not open the unit, contact IREM servicing centre !).

Installation must be carried out by trained personnel only.

This power supply must be installed inside a grounded cabinet provided with a circuit breaker duly rated.

Important note: the fuse holder powering cables are located in the lower part of the unit (see label on the front panel).

If the plant is provided with a residual current breaker having a tripping value of 30mA, this breaker could trip when switching on the power supply. This does not normally mean a failure, but is due to the capacitors of the EMI filter. Switch on the breaker again to alleviate the problem.

Feet mounting

EX-200GM3... electronic power supply is equipped with two fixing brackets that may be used as an anchoring for the unit (B) or as normal feet when the unit is normally displaced without any fixing (A).

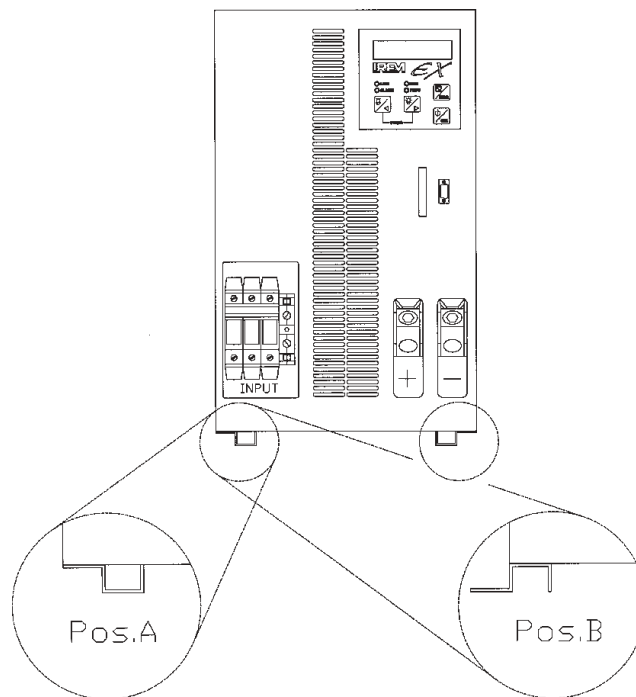

EX-200GM3

Connection and operating information

Feet mounting

If feet are used as fixing flanges, holes have to be done as per following picture:

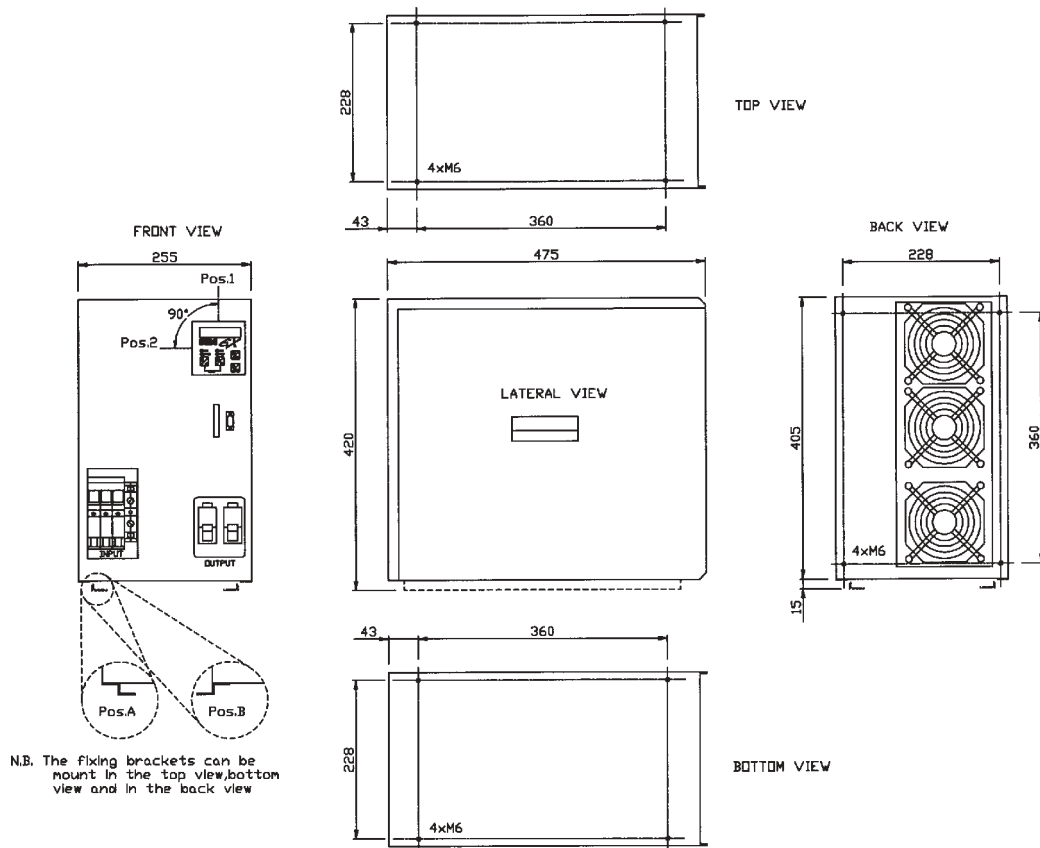

Connection and operating information

Mounting the synoptic panel

The unit may be fitted, on request, with a synoptic panel. This is not mounted onto the front panel (pict. no. 1), but is part of the delivery pack.

Vertical mounting:

Please follow the instructions below to place the synoptic panel vertically (pict. no. 2):

- Take off the metal plate on the front panel by releasing the two fixing rivets.
- Place the synoptic panel in its housing and press the two rivets to lock.

Horizontal mounting:

Please follow the instructions below to place the synoptic panel horizontally (pict. no. 3):

- Take off the metal plate on the front panel by releasing the two fixing rivets;
- Unscrew the four screws fixing the metal plate that supports the sub-D 15 pin female connector
- Rotate (90°) the metal plate supporting the sub-D 15 pin female connector
- Screw the four screws again to fix the metal plate
- Place the synoptic panel in its housing and press the two rivets to lock.

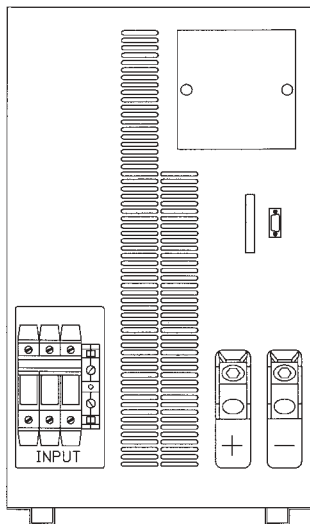

Pict. no. 1

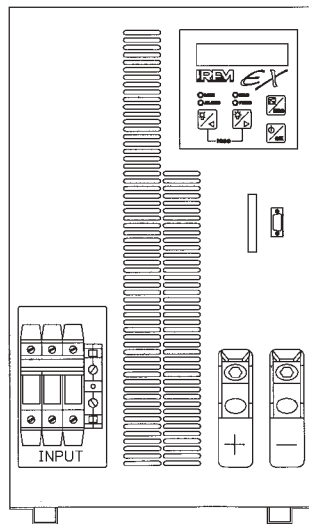

Pict. no. 2

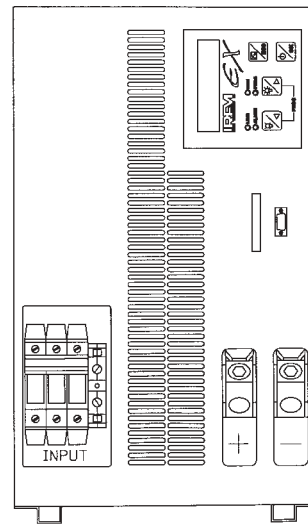

Pict. no. 3

Connection and operating information

Preliminary checks

The connection must be carried out in compliance with the current safety standards. To ensure a correct operation of the unit, please strictly follow these recommendations:

- the input powering has to be:
 - 400V version: 360-460V, 50/60Hz plus ground, withstanding a current of 23A per phase
 - 208V version: 187-230V, 50/60Hz plus ground, withstanding a current of 36A per phase
- the earth installation must comply with current standards
- the cables to be connected to the output terminals must have a size suitable to the lamp power.

During connection pay attention to the lamp polarity.

Important note: the ground connection of the power supply must be equipotential with respect to the ground connection of the lamphouse. To do this, perform a connection between the ground (PE) of the power supply and the ground of the lamphouse (cable length: 400 mm max.).

Connecting input/output cables

Connect the input/output cables to the relevant terminal board.
Pay attention to lamp polarity and terminal identification:

Input terminals

U-V-W: phases

PE: ground

Output terminals

+: positive

-: negative

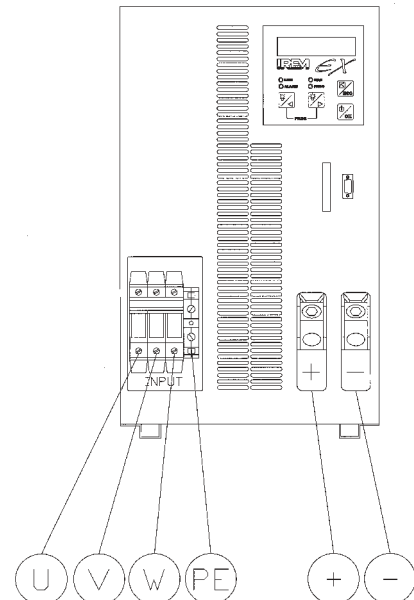

After having performed the cable connection, take in place the protective plate (see directions on next page).

Connection and operating information

Directions for inserting the protective plate

Mount the metal/lexan protective plate as per following steps:

- be sure the unit is not powered
- loose the fixing screws (B) located on the front panel (bottom)
- take in place the metal part of the plate
- tighten the screws (B) to the metal part of the protective plate
- take in place and tighten the lexan part of the protective plate
- finally, check the earth connection.

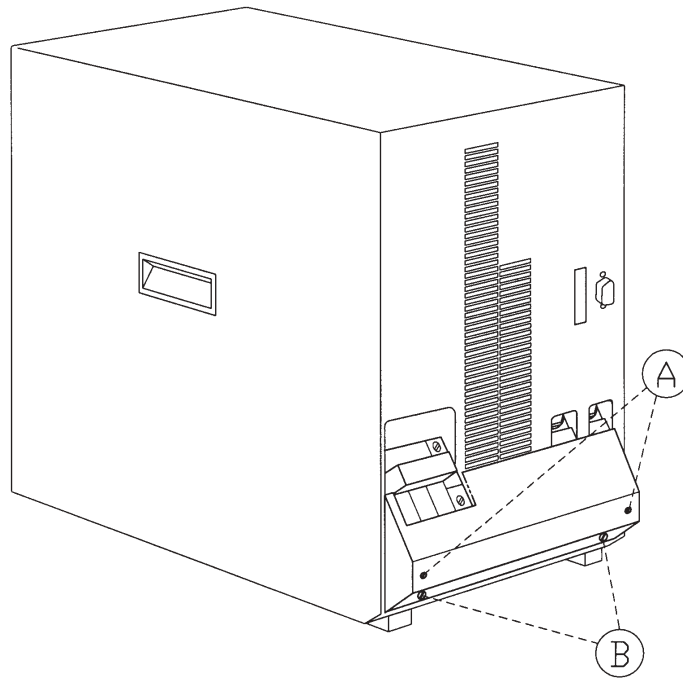

Connection and operating information

Auxiliary terminal boards

When using the remote control perform connections through J4 terminal board or J3 connector placed on the front of the unit.



Important note: different connections may cause dangerous failures to the unit !

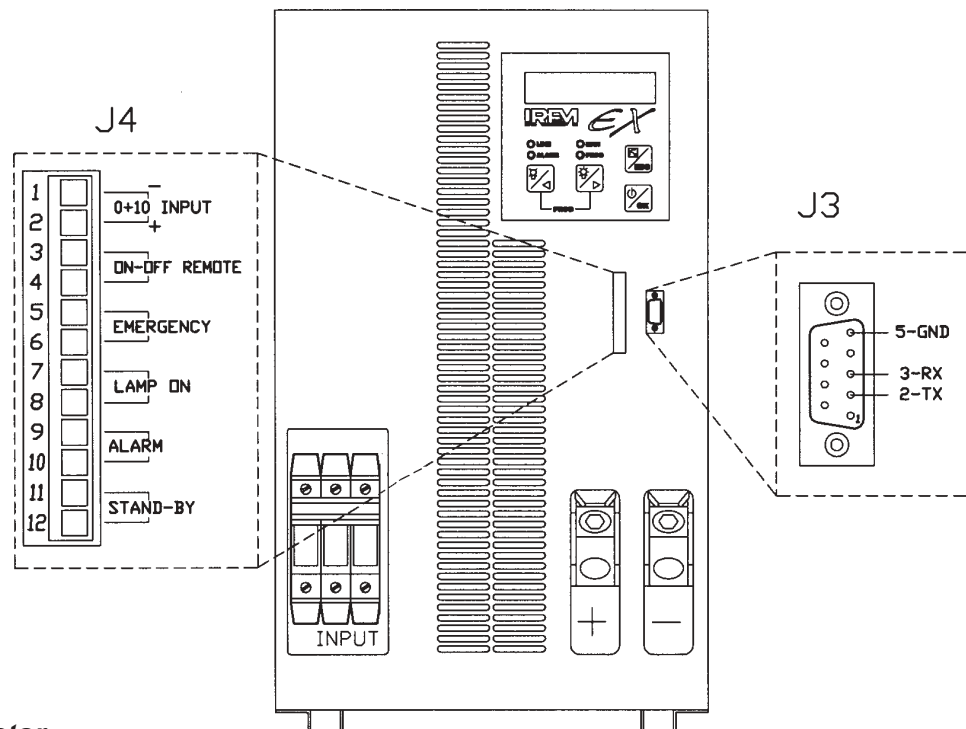

J3 connector

RS-232 serial port for remote control



We recommend to protect the input serial line by means of a galvanic insulator (on request) to avoid damages to the PC during the igniter discharge. This protection has to be connected to the PC directly.

J4 terminal board

1-2 (INPUT) 0-10V analog input for lamp current monitoring (under Ext_10V mode)

3-4 (INPUT) ON/OFF remote

Input for lamp striking under manual mode (from remote control) and Ext_10V mode (close the contact to strike the lamp)

5-6 (INPUT) Input for switching off the power supply in emergency (insert a jumper if not used)

7-8 (OUTPUT) Lamp ON output (normally open dry relay contact - 30V 1A max.)

9-10 (OUTPUT) Alarms ((normally open dry relay contact - 30V 1A max.)

11-12 (INPUT) Stand-by

(close down this contact to have the stand-by lamp current previously entered)

The connection cables to terminals 3-4 (remote), 5-6 (emergency) and 1-2 (0-10V analogue input) have to be twisted and as short as possible.

Connection and operating information

What's new

Thanks to the microprocessor control some safety functions, related to the power supply and the lamp connected to it, have been improved.

The max. power is one of the parameters that now can be set. During the operation, the power supply checks that the delivered power does not exceed the preset value. When exceeding, it reduces the delivered current down to a power (voltage by current) equal or lower than the preset limit.

If the preset power value is referred to the lamp in use, an automatic control of the max. power applied to the lamp will be obtained. The default value (10800W) aims at protecting the power supply.

The synoptic panel (if present) may be connected through a connector placed on the front of the unit. It allows to set/change the different operation modes (factory setting: RS232 mode).

The possibility to set different operating modes permits an optimum use of the power supply avoiding incorrect use.

The operation modes are exclusive i.e. when a mode has been entered, the others will be automatically ignored (i.e. if the RS232 mode has been entered, then possible commands from synoptic panel or from 0-10V analogue input will be automatically ignored).

The operation modes are: manual from synoptic panel, manual from remote control, through serial line and through 0-10V analogue input.

Two hour meters (total and partial lamp operating hours) are located on the synoptic panel. The first one (total operating hours) cannot be reset.

A remote contact (J4, pins 11-12) activates the stand-by mode. Under this mode the delivered current corresponds to the value set in "input parameters". This mode is useful during the projection timeout if the lamp must stay on. This contact can be activated under any operation mode.

Connection and operating information

Parameter setting

For more detailed information, please refer to EX communication protocol on sections: “programming the lamp parameters” and “behaviour to wrong lamp parameters sent to bytes m.s.b. command data (dh) and dato l.s.b. command data (dl) via RS232”.

Lamp P_{max} : max. power of the lamp. When entered, an automatic control will avoid exceeding this value. Factory setting: 10800W (corresponding to the max. power of the power supply).

Lamp I_{max} (operating range: 80 - 210A): lamp max. admitted current. When entered, an automatic control will avoid exceeding this value. Factory setting: 210A
When entering an I_{max} value lower than I_{min} , I_{min} will be the delivered current value.

Lamp I_{min} (operating range: 80 - 165A): lamp min. admitted current. When entered, an automatic control will avoid exceeding this value. Factory setting: 80A

Lamp stand-by (operating range: $I_{max} - I_{min}$): lamp stand-by current when the contacts 11 and 12 of J4 have been closed. When the contacts have been closed, an automatic control will change the current according to the admitted operating range. Factory setting: 80A.

The stand-by mode can be also activated through the serial line.

Factory setting of the output current: 80A.

Remarks:

1) when entering an I_{max} value lower than I_{min} the message “ERROR, $I_{max} < I_{min}$ - value not accepted” will be displayed. I_{min} will be set to 80A (default). Enter a new I_{min} value.

2) when entering a min. value exceeding 165A, 80A will be set as default value.

Directions for use

Start-up

- Be sure the emergency terminals 5/6 on J4 are short circuited through a wire if there is no emergency switch.
- If the switching on of the unit has to be performed remotely , insert a switch or two N.O. dry relay contacts between terminals 3 and 4 on J4 (ON-OFF remote)
- Before switching on the unit, be sure that the input voltage corresponds to the one shown on the data plate.
- The power supply must be ON for at least 10 seconds before activating the remote operation through the RS232 serial line (PC typically).

Getting started

- Be sure the unit has been correctly connected to the mains supply and to the lamp.
- Power the unit.
- Select the operation mode (through serial line or synoptic panel). Otherwise the default parameters (RS232 serial line) will be ON.
- Enter the lamp parameters (according to the lamp type) through the serial mode or the synoptic panel (if present). Otherwise the default parameters (i.e. the factory setting) will be ON.
- Strike the lamp according to the preset operation mode.

Functions and controls

Synoptic panel

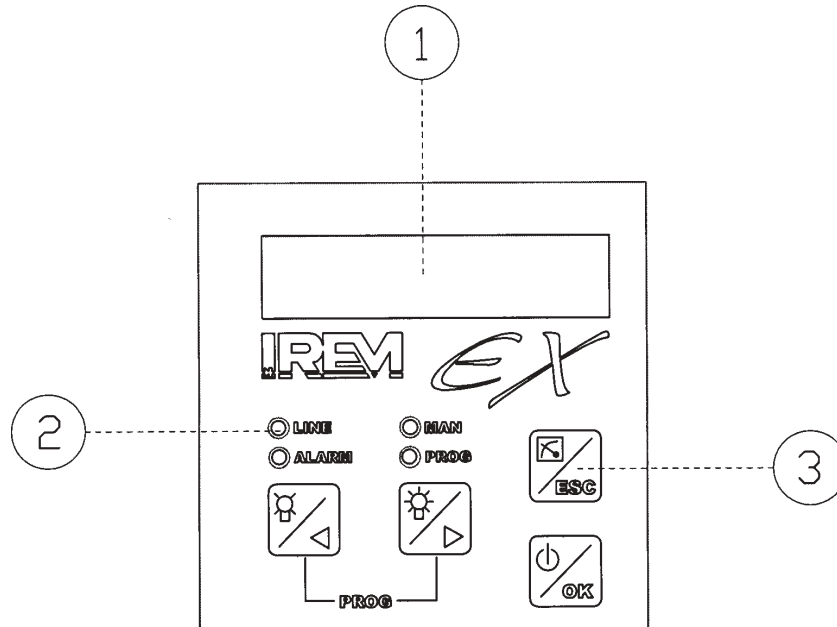

The synoptic panel is formed by:

- 1) Display
- 2) LEDs
- 3) keys for programming/displaying purposes

In details:

- 1) Display
two 16-characters lines. It is useful for displaying menus, machine parameters and measurements performed.

- 2) LEDs, lit to indicate

○ LINE	green LED	input mains ON
○ MAN	yellow LED	manual mode ON
○ PROG	yellow LED	programming mode/remote commands ON
○ ALARM	red LED	Alarms ON

- 3) Program/display keys

Dual-function keys, according to the check or setting modes selected through the synoptic panel.

Functions and controls

Synoptic panel

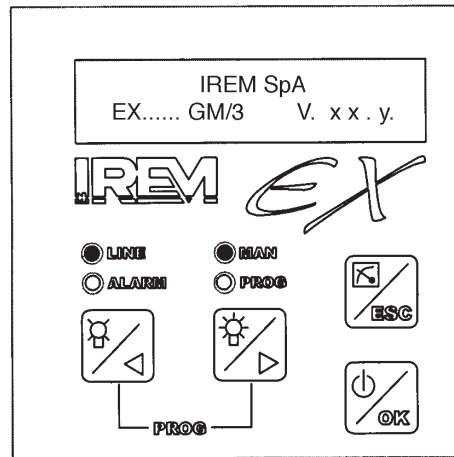

When switching on the unit, the synoptic panel will display:

1) FIRMWARE: the firmware identification is recognizable through the characters V.xx.y. displayed on the synoptic panel for 5-6 seconds after switching on (xx stands for version, while y for release).

2) DISPLAY mode

This mode is highlighted by the coming on of the following LEDs on the synoptic panel:

- . LINE LED  LINE
- . MAN LED  MAN

Keys:



to decrease the current value (active under manual operation from synoptic panel only)



to increase the current value (active under manual operation from synoptic panel only)



inverter ON/OFF (active under manual operation from synoptic panel only)
enables the output current



This key is helpful to display:

- . output current
- . output power (not displayed if the lamp has been turned off)
- . output voltage (not displayed if the lamp has been turned off)
- . unit operating temperature (not displayed if the lamp has been turned off)
- . lamp operating hours

Pressing the key "left" or "right", the displaying of "current setting" or "current output" will be activated, independently from the parameters currently on.

Functions and controls

Synoptic panel

The display lower line shows some information contained in the different fields:

X	X	X		S	Y	Y	Y	Y	w		a	a	Z	Z	Z

keys:

XXX: operation modes:

Rem = ON/OFF remote (Manual LED is ON)

Vdc = 0-10V mode

RS = RS232 mode

Remark: under manual mode (i.e. default mode) the XXX field displays no information.
The manual LED is ON.

S: (if present) the delivered current corresponds to the stand-by current

YYYY: numerical value of the displayed quantity

w: unit of measurement of the displayed quantity

aa: alarms ON signals and precisely:

e1 = over power lamp

e2 = overtemperature

ZZZ: presence of current to the output terminals

ON = current is available, power supply is ON

OFF = power supply is OFF.

To switch from MANUAL to PROGRAM mode press the keys



at the same time.

Functions and controls

Synoptic panel

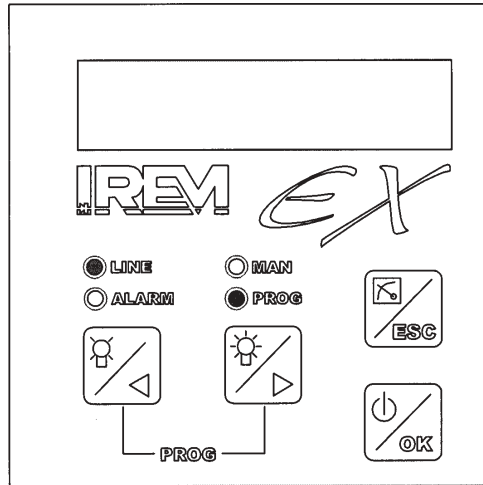

2) Under PROGRAM mode.

This operating condition is highlighted by the coming on of the following LEDs on the synoptic panel:

- . LINE LED
- . PROG LED

Important note: enter the password to modify the operating parameters !

The password is: **125**

Detailed instructions for entering the password have to be found in the relevant flow-charts.

Keys:



to increase/decrease the values to be entered
or to shift to the various fields



to confirm the value/parameter entered

Parameter/operation modes to be entered under program mode are:

1. lamp max. power
2. lamp max. current
3. lamp min. current
4. lamp stand-by current (remote-operated)
5. manual mode (from synoptic panel or remote command)
6. or RS232 operation mode
7. or Ext_10V operation mode



to quit the submenu

Directions for use

Through synoptic panel

When switching on the unit, the first screen displays the manufacturer's name and the appliance model. Display menu is now available.

The available menus are:

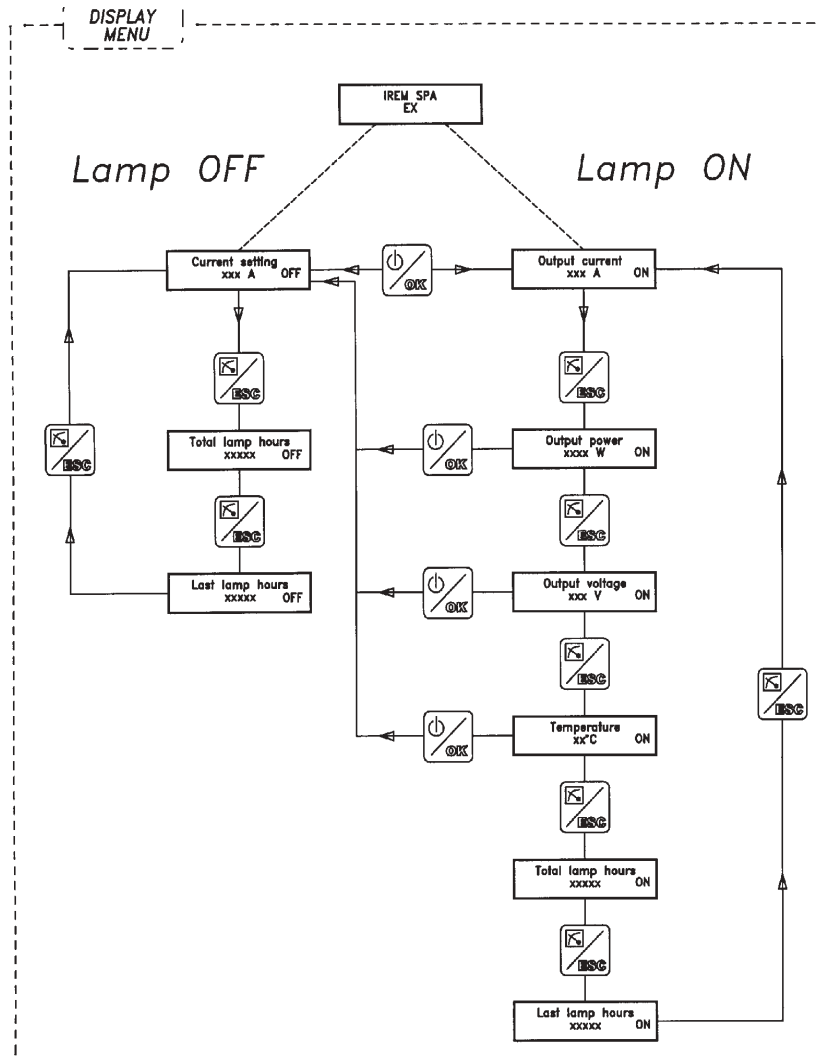

- 1) display menu
- 2) program menu.

Display menu



Directions for use

Directions for data entering (through synoptic panel)









- 1) Press the keys    at the same time to enter the PROGRAM mode (program menu).
Afterwards, enter the password to have access to data entry and modification of the preset parameters. If the password is incorrect or unknown, quit the menu by entering (as shown in the flowchart) any number. This will allow to go back to display menu (after the access has been denied).
- 2) From any position of the program menu twice press the key ESC to go back to display menu.
- 3) Parameter setting menu or mode menu: the asterisk (on the right of the parameter) means you are entering/modifying the setting (at the same time, a flashing dash on the field to be modified is ON). The absence of this asterisk indicates the value of the parameter currently active.
- 4) The lamp turns off when entering "input parameters" and/or "operation" modes.

Directions for use

Directions for data entering (through synoptic panel)

An example

setting the lamp parameters (from 7000W down to 5755W)

From lamp parameter display menu press OK to enter the editing mode (the dash starts to flash: enter mode is ON).		<div style="border: 1px solid black; padding: 2px; width: fit-content;">Lamp Parameters Pmax : 7000 W</div>
Press the left arrow to decrease the “thousands” field down to the desired value		<div style="border: 1px solid black; padding: 2px; width: fit-content;">Lamp Parameters Pmax : <u>6</u>000 W * Pmax : <u>5</u>000 W *</div>
Confirm by pressing enter. The flashing dash moves to right.		<div style="border: 1px solid black; padding: 2px; width: fit-content;">Lamp Parameters Pmax : 5<u>0</u>00 W *</div>
To increase the value currently active press the right arrow		<div style="border: 1px solid black; padding: 2px; width: fit-content;">Lamp Parameters Pmax : 5<u>4</u>00 W * Pmax : 5<u>7</u>00 W *</div>
When pressing enter, the flashing dash will immediately move to the next field to be modified.		<div style="border: 1px solid black; padding: 2px; width: fit-content;">Lamp Parameters Pmax : 57<u>0</u>0 W *</div>
		<div style="border: 1px solid black; padding: 2px; width: fit-content;">Lamp Parameters Pmax : 57<u>1</u>0 W * Pmax : 57<u>5</u>0 W *</div>
		<div style="border: 1px solid black; padding: 2px; width: fit-content;">Lamp Parameters Pmax : 575<u>0</u> W *</div>
When the last field (the unit one) has been entered, press enter to confirm the value.		<div style="border: 1px solid black; padding: 2px; width: fit-content;">Lamp Parameters Pmax : 575<u>1</u>W * Pmax : 575<u>5</u>W *</div>
The asterisk is off: the editing mode is over.		<div style="border: 1px solid black; padding: 2px; width: fit-content;">Lamp Parameters Pmax : 5755 W</div>

Directions for use

Entering the password (through synoptic panel)

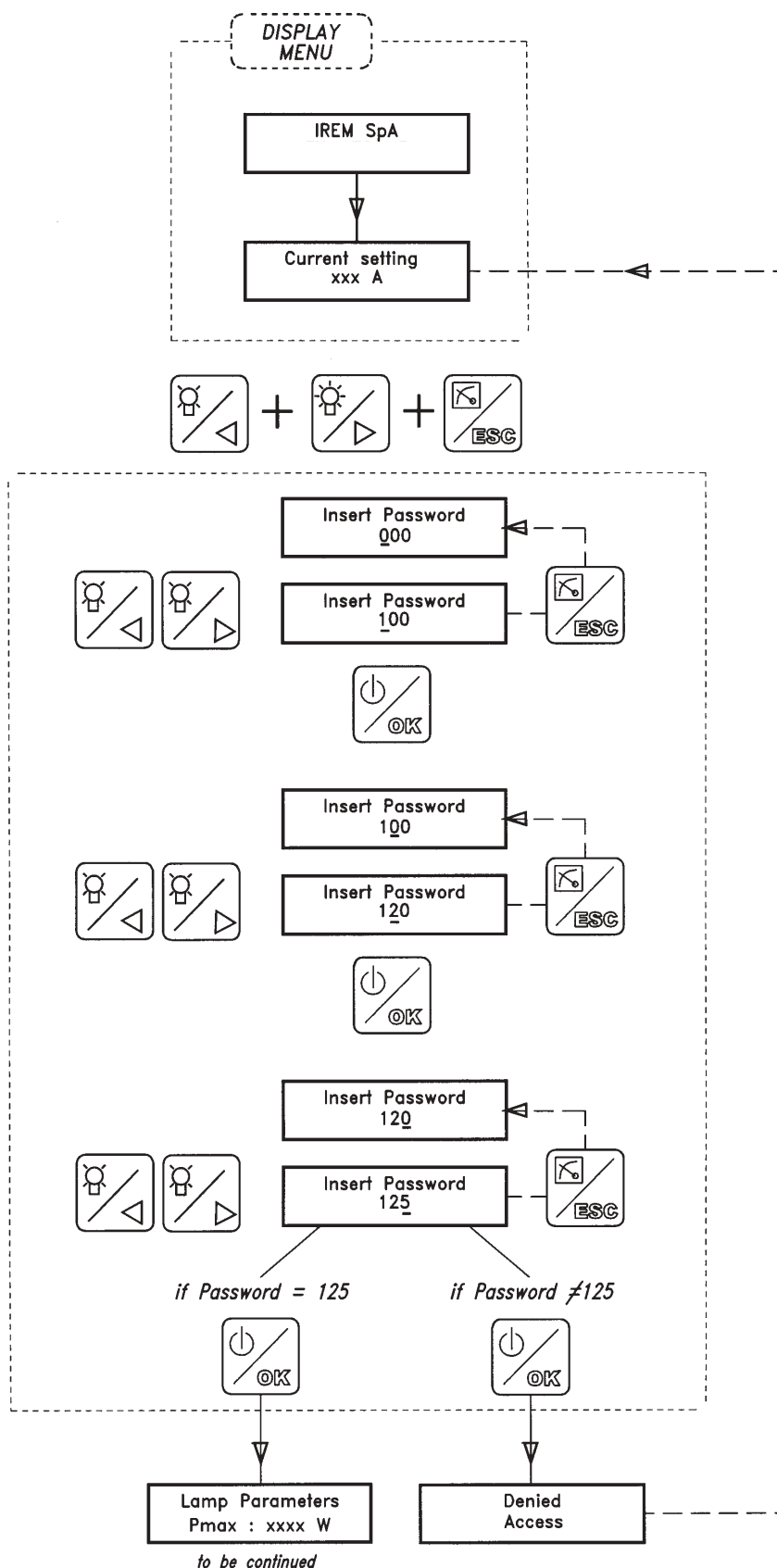

Directions for use

Program menu - Parameter setting through synoptic panel

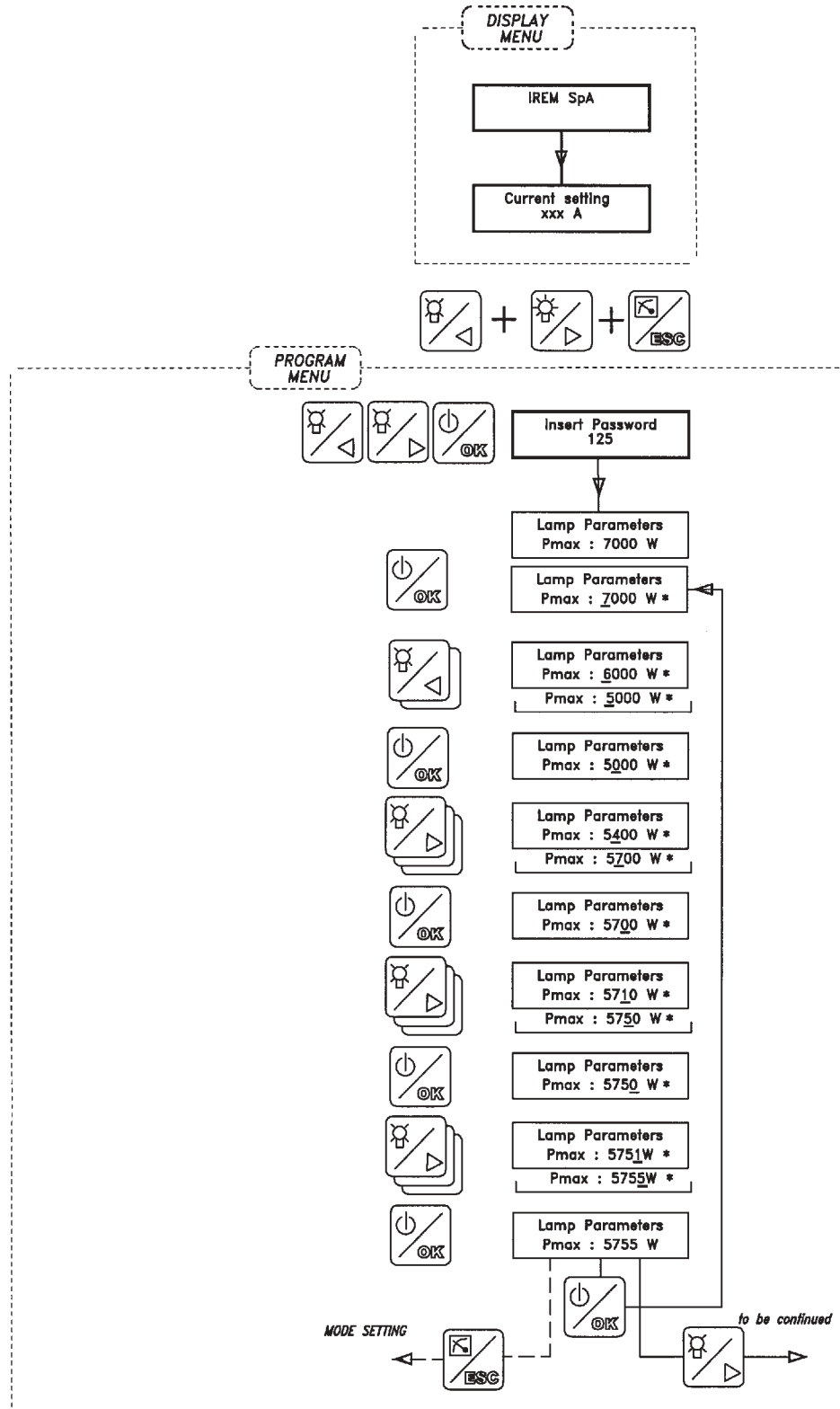

Directions for use

Program menu - Parameter setting through synoptic panel

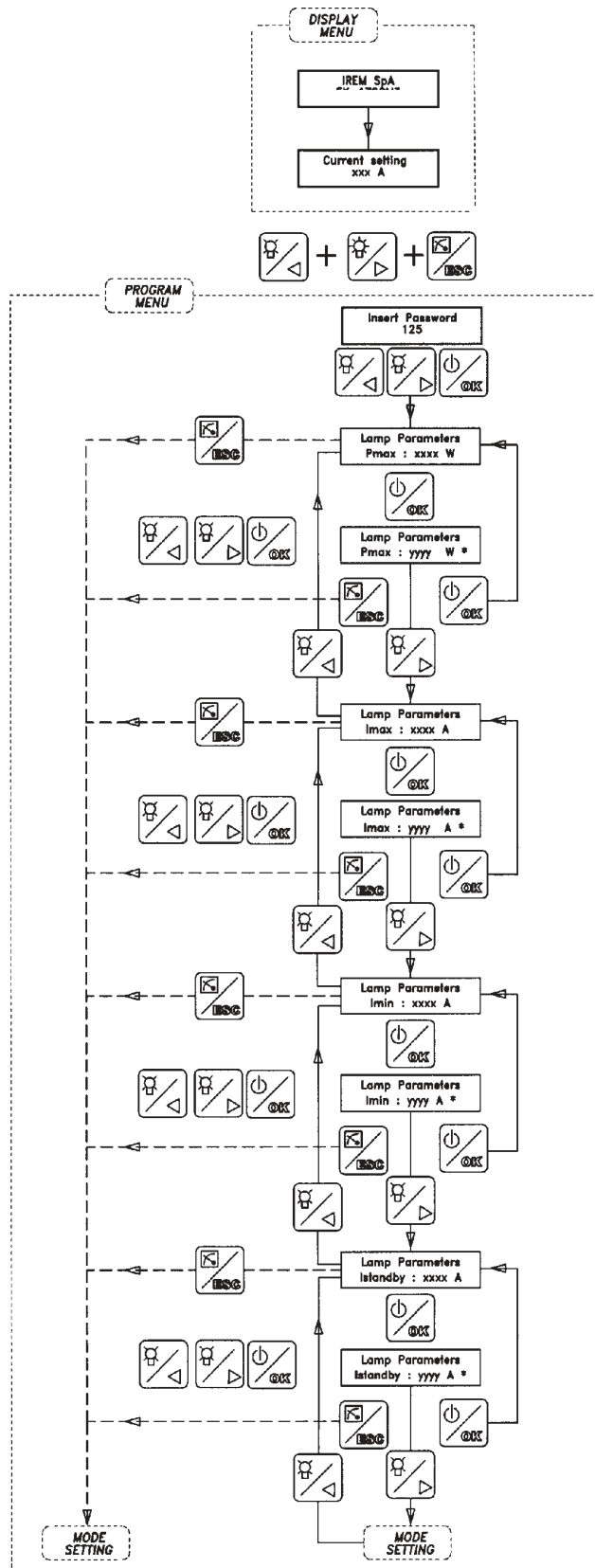

Directions for use

Operation modes

The three operation modes can be used alternately but not all at the same time. When the RS232 serial line (default setting) is ON, the operating parameters will be set through this line (see the communication protocol for more detailed information). If you have not yet developed your own software, apply for IREM demo software. From synoptic panel: act on the keys to shift from one mode to the other.

From any mode, press the keys    to change the operation mode.

Manual mode

Under this condition the lamp current setting is managed through the synoptic panel (press left (decreasing) key and right (increasing) key). The lamp current range has to be within 80A and 210A.

Press the ON/OFF key  to switch on/off the lamp.

Note: under manual mode from remote control, the switching on must be forced by short circuiting contacts 3 and 4 of J4 terminal board. Under this operating condition the synoptic panel is no longer operative.

Ext_10V mode

Under this mode the output current is set through the 0-10V analog input. 0V in input will correspond to the min. current value (factory setting: 80A). 10V in input will correspond to the max. current value (factory setting: 210A). Current values (max./min.) will change according to the user's settings. Switching on/off may be performed by short circuiting contacts 3 and 4 of J4 terminal board by means of a dry relay contact.



RS232 mode (default)

When this operation mode is active, the operating parameters of the unit are controlled and monitored through the RS232 line.

Directions for use

Resetting the lamp hour meter (through synoptic panel)

When replacing the lamp it is possible to manually reset its hour meter.

Enter the relevant menu (see picture below) and press   keys at the same time.

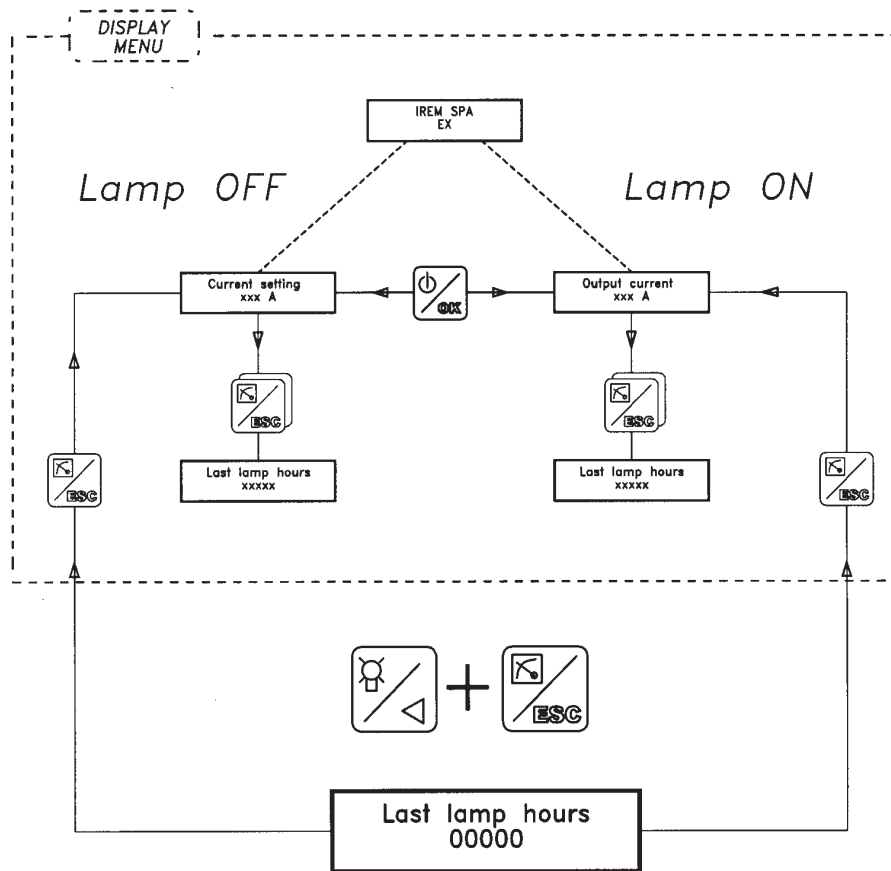

Maintenance

Replacing the fans

In case of fan replacement, please carry out the following steps:

- take off the two screws (1) fixing the fan panel
- take off the fan panel (2) paying attention not to damage the wiring
- disconnect the fan (4) from X3 (5) terminal board
- remove the four fixing screws (3) and take off the fan

Important note: fan (4) must be correctly placed! The air has to flow from the inside to the outside of the unit.

- fix the new fan to its panel by means of the relevant screws. Connect the fan to X3 terminal board paying attention to the cable polarity.
- Take in place the fan panel paying attention not to damage the wiring and fix it by means of the two screws (1).

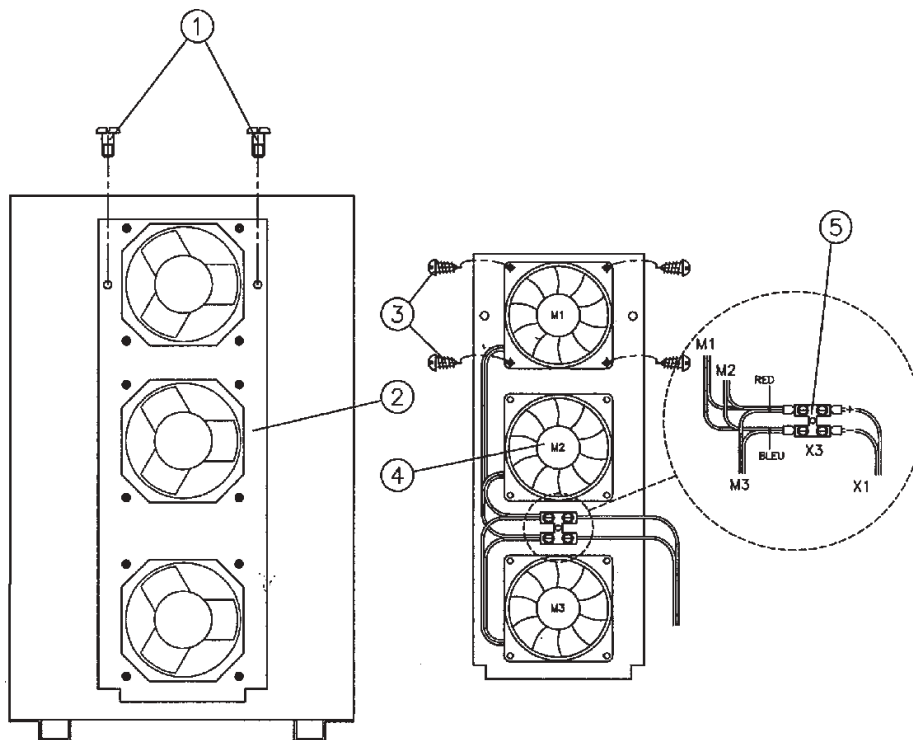

Alarms/faults

Corrective steps

When activating the emergency switch, the lamp turns off. Switch off the unit and then wait 15 seconds before resetting. Afterwards the power supply is ready for switching on.

Byte "Fault" becomes 6 when answering to r command (refer to the communication protocol). Byte "Fault" will reset when switching the power supply on. Otherwise, but only under RS232 and manual with switching on from synoptic panel (if present): close the emergency contact. Then wait approx. 7 seconds (the serial communication is disabled during this 7 seconds time).

The power supply has been fitted with some protection devices against overtemperature and overpower. In case of overtemperature or overpower, alarms will be ON.

When the max. power has been exceeded:

- . the lamp does not turn off
- . ON/OFF byte is set to 5 when answering to L command
- . J4 9-10 contacts close down
- . the power supply controls the current to limit the output power
- . to switch back to normal operation and clear alarms, turn off the power supply.

A sensor controls the internal temperature for a safe operation of the power supply. In the event the temperature limits have been exceeded:

- . ON/OFF byte is set to 3 during 95 seconds when answering to L command
- . the lamp will be turned off after 95 seconds. After the lamp turn-off byte ON/OFF becomes 2.
- . J4 9-10 contacts close down.
- . send F command to switch off/reset the unit
- . allow the cooling of the unit and check the ON/OFF byte (equal to 0) through L command
- . strike the lamp.

In case the requirements for ground equipotential conditions do not comply with, some troubles could occur when striking the lamp. For more detailed information, please refer to the EX communication protocol section "fault control procedure (only through RS232)".

Alarm/fault displaying (synoptic panel)

Corrective steps

When activating the emergency switch, the lamp turns off. The synoptic panel will display "emergency - switch off mains". Switch off the unit and then wait 15 seconds for resetting. Afterwards the power supply is ready for switching on.

Otherwise, but only under RS232 and manual with switching on from synoptic panel modes: close the emergency contact. Then wait approx. 7 seconds (the serial communication is disabled during this 7 seconds time).

The power supply has been fitted with some protection devices against overtemperature and overload. In case of overtemperature or overload, alarms will be ON.

When the max. power has been exceeded:

- . the lamp does not turn off
- . the display lower line will display: e 1
- . the alarm LED comes on and J4 9-10 contact closes down
- . the power supply controls the current to limit the output power
- . turn off the power supply to reset.

A sensor controls the internal temperature for a safe operation of the power supply. In the event the temperature limits have been exceeded:

- . the display lower line will display: e 2
- . the lamp will be turned off after 90 seconds
- . the alarm LED stays on and J4 9-10 contact closes down.
- . press OK to reset (the display is cleared, the alarm LED comes off, the remote contact opens)
- . press OK once again to strike the lamp.

When the power supply is ON it is possible to remove/disconnect the synoptic panel only under Ext_10V and RS232 modes. If removed under manual mode, the power supply will turn off after 6 seconds. Consequently no information will be displayed/available on the power supply status.

The insertion of the synoptic panel is not possible when the power supply is on: in this case the lamp could turn off and the data referred to the hour meters could be lost. To correctly insert the synoptic panel: turn off the power supply, wait 15 seconds and then insert it. Finally, turn on the power supply again.



Alarm/fault displaying (synoptic panel)

Corrective steps

In case the requirements for equipotential conditions do not comply with, the following troubles could occur when striking the lamp:

1. The power supply does not strike the lamp, the alarm LED comes on:
 - after about 1 second, the power supply will reset: the alarm LED comes off and “current setting” will be displayed. Press OK to restrike the lamp.
 - under ON/OFF remote operation: a new striking will be performed automatically.
 - under RS232 operation: the lamp off signal is sent to the remote device. Afterward a new striking command will be sent.
2. The power supply does not strike the lamp, the display is off or some unrecognizable characters are displayed:
 - disconnect the unit from the mains.
 - close the RS232 communication from remote device
 - switch on the power supply again and wait for “current setting” displaying or, if the synoptic panel is not connected, wait 15 seconds before reconnecting through the serial line
 - strike the lamp again.
3. The power supply does not strike the lamp. “EEprom data error EX halted” is displayed.

In this condition, the synoptic panel must be connected to the power supply to allow the manual operation mode.

 - press and hold OK for at least 1 second. “Reset Ex. Set up parameters. wait” will be displayed.
 - the default parameters (factory settings) will be restored and the two hour meters reset.
 - the power supply switches to program mode (input parameters). Enter operating parameters and RS232 mode again.
4. The RS232 communication does not operate or the power supply has to be reset. If the communication with the PC does not operate, reset the power supply to alleviate the problem. To reset the unit act as follows:
 - go to program menu
 - the screen will display “enter the password”.
 - press the keys  and  at the same time.
 - the screen will display “Reset Ex. Set up parameters. wait”: the operating parameters will be the default ones (i.e. the factory setting).
 - set your usual parameters again.
 - start the RS232 communication.

EX-200GM3

Overall dimensions

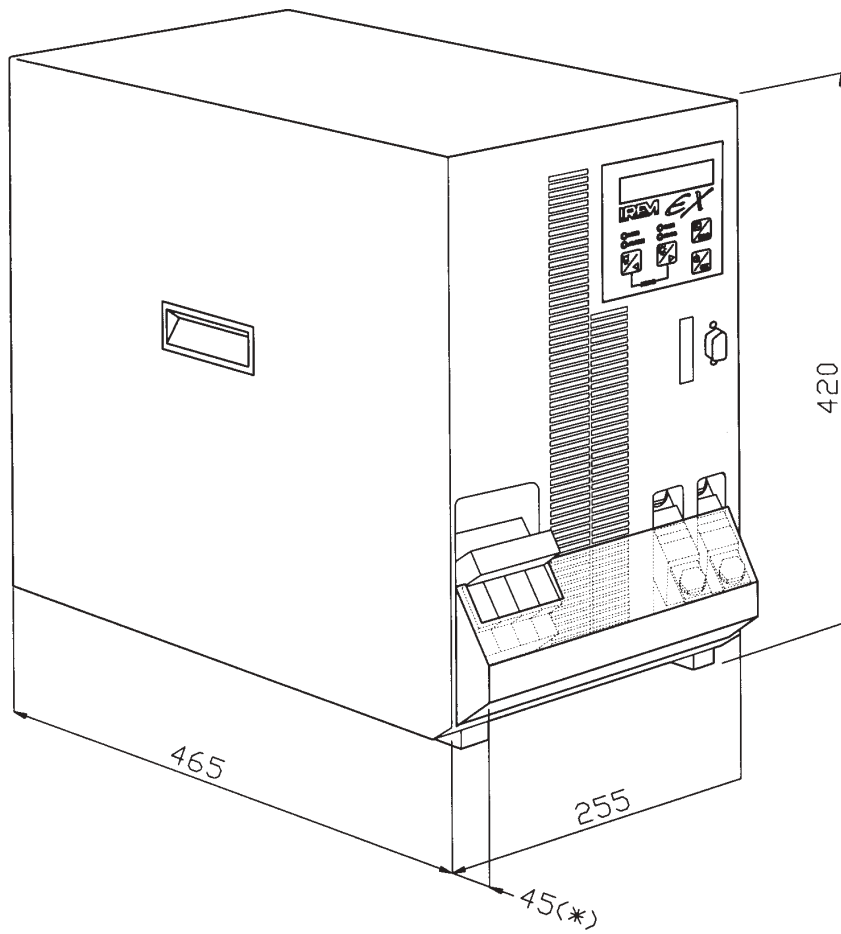

INFORMATION ABOUT DISPOSAL OF THE APPLIANCE

Do not treat the appliance as unsorted municipal waste.

The disposed appliance must be consigned to the authorized treatment facilities for proper recycling/reuse and disposal.

An incorrect disposal may cause harmful effects on environment and human health.

DICHIARAZIONE DI CONFORMITA'

La IREM SpA, con sede legale in Via Rocciamelone, 58 – 10050 S. Antonino di Susa (TO) – Italia, dichiara che il seguente prodotto:

Raddrizzatore elettronico EX-200 GM/3-E

è conforme alle seguenti norme:

EN 61347-1
EN 61000-6-2
EN 61000-6-4
EN 61000-3-11

per rispondere alle Direttive:

BT 73/23/CEE e 93/68/CEE - anno di apposizione del marchio  : 04
EMC 89/336/CEE, 92/31/CEE e 93/68/CEE

CONFORMITY DECLARATION

IREM SpA, with registered office in 10050 S. Antonino di Susa (Turin) – Italy, Via Rocciamelone, 58, hereby states and declares that the following product:

Electronic Power Supply EX-200 GM/3-E

complies with the regulations listed below:

EN 61347-1
EN 61000-6-2
EN 61000-6-4
EN 61000-3-11

to satisfy the requirements of the following directives:

LVD 73/23/EEC and 93/68/EEC -  marking: as from 04
EMC 89/336/EEC, 92/31/EEC and 93/68/EEC

DDC0354-01
S. Antonino 17/06/04

IREM SpA
Giuseppina Celso
Managing Director



DECLARATION DE CONFORMITE

La société IREM SpA, ayant son domicile légal à 10050 S. Antonino di Susa (Turin) – Italie, via Rocciamelone 58, déclare que l'appareil suivant:

Redresseur Electronique EX-200 GM/3-E

est conforme aux normes suivantes:

EN 61347-1
EN 61000-6-2
EN 61000-6-4
EN 61000-3-11

Pour satisfaire aux conditions requises par les directives:

BT 73/23/CEE et 93/68/CEE - marquage : à partir de 04
CEM 89/336/CEE, 92/31/CEE et 93/68/CEE

- VERTRÄGLICHKEITSBESCHEINIGUNG

Die Firma IREM SpA, mit Standort in 10050 S. Antonino di Susa (Turin) – Italien, Via Rocciamelone, 58 bestätigt, daß das Gerät:

Elektronischer Gleichrichter EX-200 GM/3-E

den folgenden Vorschriften entspricht:

EN 61347-1
EN 61000-6-2
EN 61000-6-4
EN 61000-3-11

um den Ansprüchen der folgenden Richtlinien nachzukommen:

NU 73/23/EWG, und 93/68/EWG - Kennzeichen: ab 04
EMV 89/336/EWG, 92/31/EWG und 93/68/EWG

DDC0354-01
S. Antonino 17/06/04

IREM SpA
Giuseppina Celso
Managing Director

