

# FILM-TECH

**THE INFORMATION CONTAINED IN THIS ADOBE ACROBAT PDF FILE IS PROVIDED AT YOUR OWN RISK AND GOOD JUDGMENT.**

**THESE MANUALS ARE DESIGNED TO FACILITATE THE EXCHANGE OF INFORMATION RELATED TO CINEMA PROJECTION AND FILM HANDLING, WITH NO WARRANTIES NOR OBLIGATIONS FROM THE AUTHORS, FOR QUALIFIED FIELD SERVICE ENGINEERS.**

**IF YOU ARE NOT A QUALIFIED TECHNICIAN, PLEASE MAKE NO ADJUSTMENTS TO ANYTHING YOU MAY READ ABOUT IN THESE ADOBE MANUAL DOWNLOADS.**

**[WWW.FILM-TECH.COM](http://WWW.FILM-TECH.COM)**

# DSTR-20

Digital Penthouse Reader

---

---

INSTRUCTIONAL MANUAL



181 Bonetti Dr  
San Luis Obispo, CA  
93401 USA  
ph: 805-549-0161  
fax: 805-549-0163  
e-mail: usl@uslinc.com



1025 Pine Meadows Ct  
Martinez, CA  
94553 USA  
ph: 925-372-7603  
fax: 925-372-7658  
e-mail: bacp2000@aol.com

## One Year Limited Warranty



USL, Inc. warrants that each product manufactured by it will be free from defects in material and workmanship under normal usage for a period of one (1) year after its purchase new from an authorized dealer. Our obligation under this warranty is limited to repairing or replacing any product or component which we are satisfied does not conform with the foregoing warranty and which is returned to our factory, freight paid, or serviced by one of our authorized contractors. The foregoing warranty is exclusive and in lieu of all other warranties, whether expressed or implied. Such warranty shall not apply to any product or component (A) repaired or altered by anyone other than USL, Inc. or an authorized service contractor; (B) tampered with or altered in any way or subjected to misuse, negligence or accident or (C) which has been improperly connected installed or adjusted other than in accordance with USL, Inc.'s instruction.

# Table of Contents

<u>Topic</u>	<u>Page</u>
Installation Overview.....	3
Mechanical Installation.....	3
Delay Setting.....	5
Installing the Video Cable and Flywheel.....	5
Reader Alignment.....	7
LED Adjustment.....	8
Focus, Azimuth and CCD lateral adjustment.....	8
Fig. 1: Reader, Back View.....	4
Fig. 2: Reader, Front View.....	6
Fig. 3: SR.D Video Display.....	7

## Introduction and Installation Overview

The DSTR-20 is a lower cost penthouse-style SR.D soundtrack reader with a number of new features. These include circuitry to enhance bit readability and a video status light that signals adequate video level. A new, more efficient imaging lens design allows the use of an internal LED current supply that derives its power from the +/- 15 Volt rails of the Dolby Digital processor. Thus, there is no need for external AC power. A user-replaceable LED module rounds out the feature list.

The DSTR-20 will attach directly to the Christie, Cinemeccanica, Century, Ballantyne, and Simplex projectors using one of the bolt pattern sets provided on the bottom of the reader case.

### **Adaptor plates are available for the following projectors**

Norelco AA-11/DP70	Dolby Cat. No. 695
Kinoton DP75/FP20, FP30	Dolby Cat. No. 696

A number of standard bolt pattern sets are also provided to accommodate film magazines, reel arms or film guidance hardware. Cinemeccanica projectors do require an adaptor plate (Dolby Cat. No. 690) to attach its standard upper reel arm to the DSTR-20.

## Mechanical Installation

**NOTE:** While every effort has been made to assure the robustness and reliability of the DSTR-20, it must be understood that it is primarily a precision opto-mechanical device built to exacting tolerances and must never be handled without due concern.

Unpack reader and locate its packing kit, flywheel, and video cable. The reader is shipped with a 30 Ft. (10 meter) cable. Longer video cables are available on request.

Remove the back cover

Attach reader to top of projector using the bolts provided. Since projectors tend to have custom features, some improvisation may be required to accommodate the douser, film cleaner brackets, etc.

Attach the reel arm/film guidance hardware to the top of the reader. Verify that bolts clear the reader's internal components before tightening. Thread film through film guidance hardware, reader, and upper part of the projector. Adjust the reader and reel arm so film runs straight and true without rubbing or binding. Tighten attaching bolts. Install flywheel as shown in Figure 1 by slipping on to shaft and aligning the set screw with the notch on the drum shaft. The setscrew should tighten into the notch,

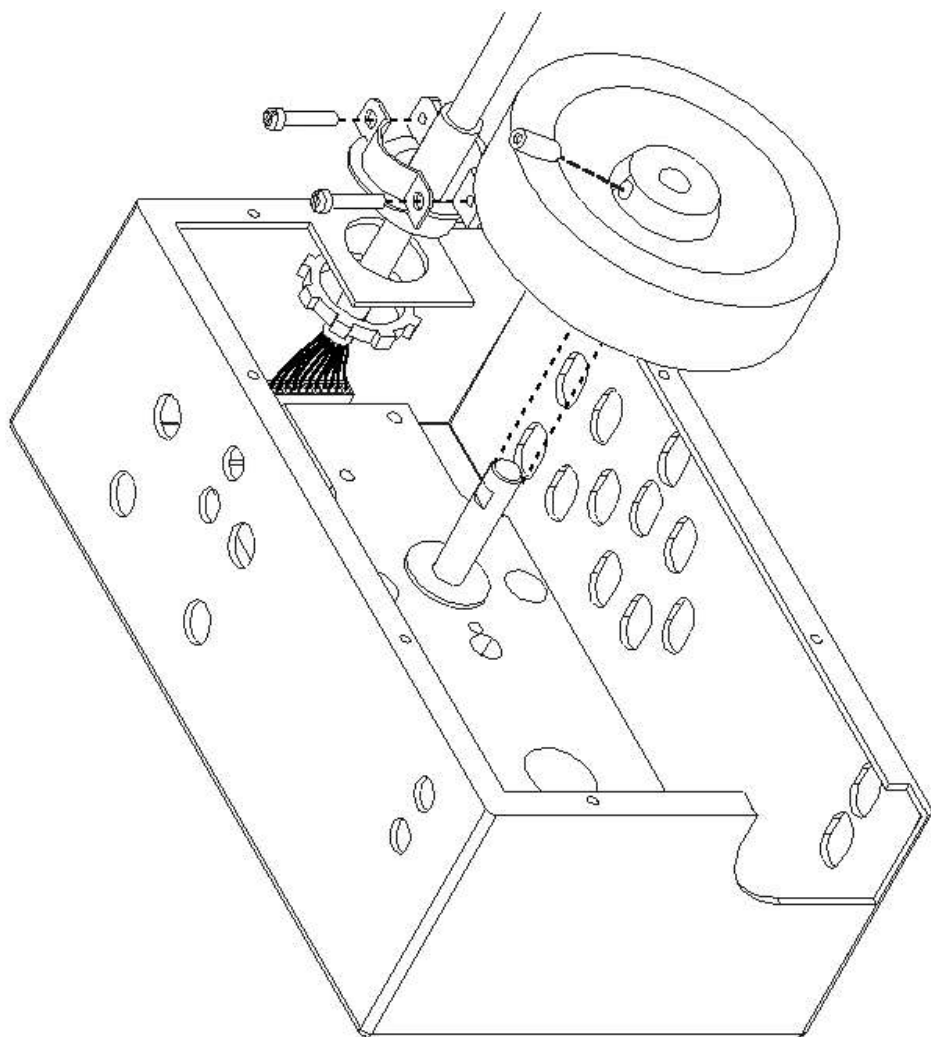

FIGURE 1

## Reader Delay Setting

This reader uses the same delay setting as the Dolby® Cat 701 Reader +/- a perforation. There are a number of methods to set the delay: a dedicated sync loop, the SR.D Jiffy test film and setup menu in the CP500 and CP650.

## Installing the Video Cable and Flywheel



**Note: Turn off Dolby® processor power before attaching cable to reader or cinema processor. Do not hot-plug this cable as you may destroy the reader CCD card, Dolby® video board, or both.**

Run the video cable through the hole provided in the back of the reader and plug it into the CCD board connector. A separate ground lug is provided to bond the cable to the reader chassis. Tighten wire clamp around the cable. Plug the other end of cable into the Dolby® processor.



**Please confirm the cable is plugged into reader connector, pin for pin. Misaligned pins will cause damage to sensor board or Dolby® Processor.**

Remove the protective boot from sound drum shaft and attach flywheel taking care to line up the set screw with the slot in the Sound Drum Shaft. Be careful not to lose the thrust spring.

Replace the back cover. Restore AC power to Dolby® processor.

Thread and run a film loop or reel with a Dolby® Digital soundtrack. Check the error rate displayed on the Dolby® Digital processor. Today's feature films and previews typically run at error rates 3 and below. The video status light should go green with film is running. This indicates an adequate video level (2 Volts or more) for correct operation. The light will turn red for a number of reasons including low LED output or a dirty lens.

**The alignment of the reader is set at the factory and should not require further adjustment.**

Reader video alignment can be checked if necessary using the instruction below. Installation is now complete

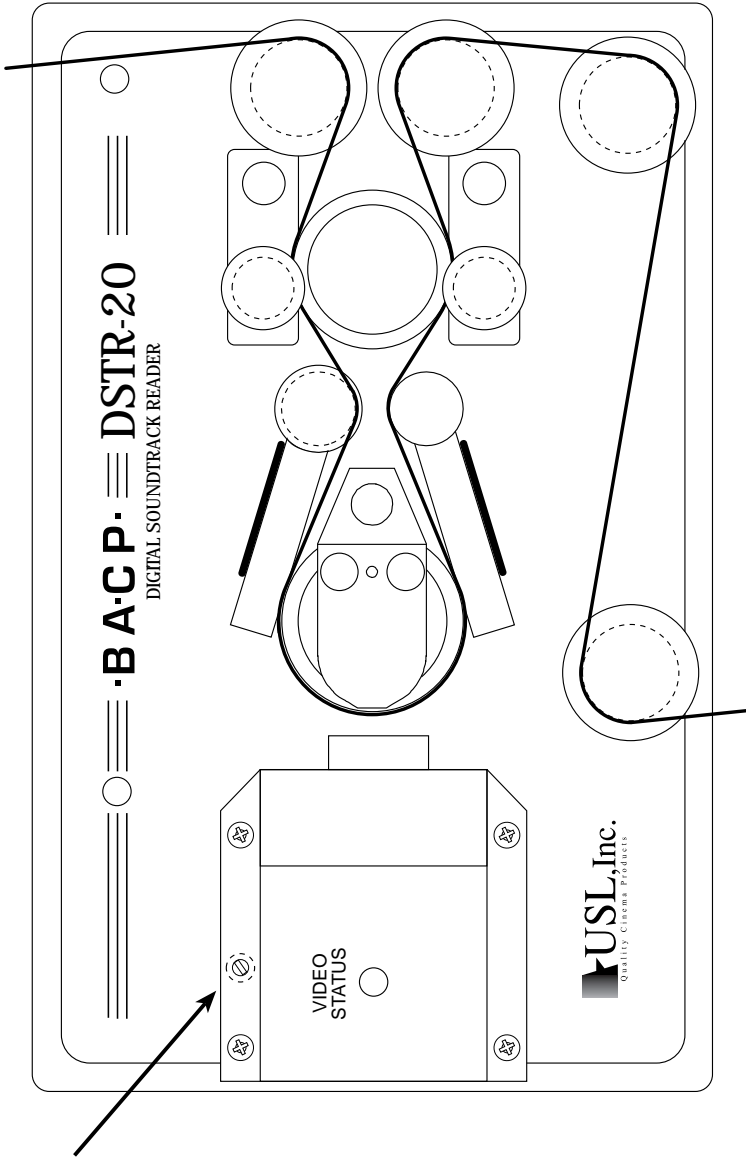

LED current trim pot

FIGURE 2



## Reader Alignment

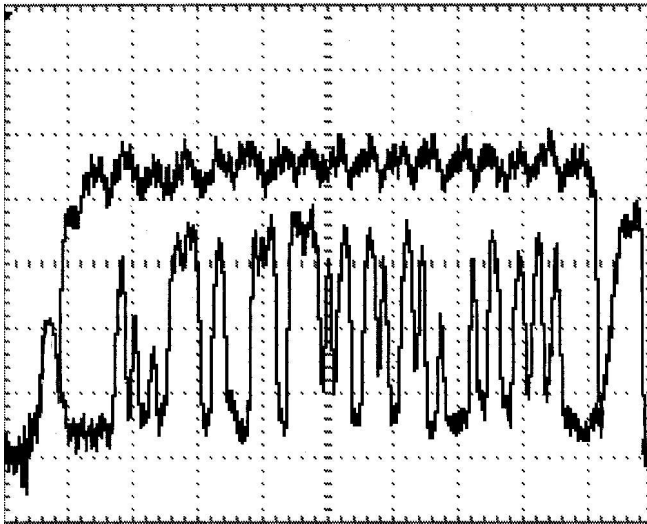

SR.D VIDEO DISPLAY

FIGURE 3

The reader is shipped pre-aligned for 4.5 volts Video output. The following procedure requires a wide bandwidth oscilloscope (20 MHz or better) and may be used to verify correct initial operation and also to troubleshoot the unit should service be required in the future. Focus and video output level may be easily adjusted using only this instrument. A laptop with Dolby® DRAS software may also be used to measure and display data about the reader and the film being run.

Connect the oscilloscope to Dolby® Digital processor as follows: connect scope channel 1 probe to Video test point and its ground test probe to the ground test point. Connect scope channel 2 to the Clamp test point.

Set scope channels 1 and 2 to 1 Volt sensitivity, DC coupling, calibrated. Set horizontal sweep rate to 2 us/division.

Run Cat. No. 69T film loop to generate a video signal.

Adjust scope trigger level to stabilize on the clamp signal.

Adjust horizontal position to inside edge of left clamp signal with the scope's left screen graticule.

Adjust horizontal sweep vernier to line up inside edge of the right screen clamp signal with right screen graticule as shown in Fig. 3.

Adjust the scope channel 1 vertical position so the bottom of the video display is even with the lowest horizontal graticule. The video output level should be comfortably above 2 Volts for proper operation.

## LED Mechanical Adjustment

Verify correct LED position by loosening the two LED/heat sink screws and rotate for maximum video output. Tighten screws.

## LED Current Adjustment

As time passes, the LED output will diminish. Our initial LED current setting of about 140 mA should ensure years of service before the video output level drops below the established minimum of 1.5 Volts video output. The video status light will turn from green to red indicating it is time for a service call.

LED current can be adjusted by means of a trim pot located beneath the CCD/Lens cover. Remove the cover and adjust the trim pot to yield 4.5 Volts video output on the scope.

## Focus, Azimuth and CCD lateral adjustment

Azimuth is adjusted by rotating the sensor PC board. When properly adjusted, the DRAS software display should indicate an azimuth of  $\emptyset$  degrees. Focus is adjusted by loosening the lens clamp screw and turning the knurled lens nut to adjust the lens in and out for best video resolution on the scope or DRAS. CCD horizontal position is adjusted by loosening the PC board screws and sliding the CCD board in and out until the DRAS perforation display is centered.

---

**Note:** In all cases, an oscilloscope is required for viewing the video output signal during CCD focus, alignment and initial Red LED current adjustment. Re-adjust the Red LED current if the Status Light LED displays red during an SRD film.

---

## Sensor Board Status Light Circuit

After focus and alignment of the Sensor Board, running an SRD film, increase the Red LED current until the Status Light displays yellow, and then back the current down until the Status Light LED displays green. This is the maximum video voltage of the normal video range.

LED color (Status Light)	Video Description	Video Range
Red	Low	0.0 -1.5V
Green	Normal	1.5 - 4.5V
Yellow	High	>4.5V

**Video Cable Pinout Chart**

25 PIN	MOLEX #	COLOR	SHIELD	SIGNAL
1				NC
2				NC
3				NC
4	7	Blue	Pair 3 Blue	TTC
5	9	Shield		TC Gnd
6	8	Black		FTC
7	10	White	Pair 4 Green	TSC
8	11	Shield		SC Gnd
9	12	Black		FSC
10				NC
11				NC
12				NC
13				NC
14	1	Black	Pair 1 Red	Video 0
15	2	Shield		Gnd
16	6	Red		+15V
17	3	Black	Pair 2 Blue	Video 1
18	5	Shield		Gnd
19	4	Green		-15V
20				NC
25				NC

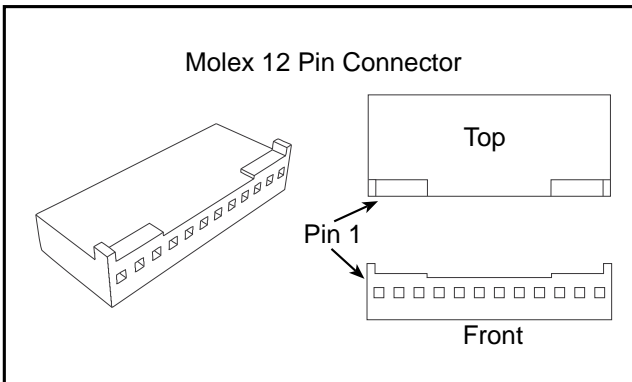

Molex Pin no.	Wire color	Cable Pair sheild color	Signal name
1	Black	Red	Video 0
2	Shield	Red	GND
3	Black	Blue	Video 1
4	Green	Blue	-15 V
5	Shield	Blue	GND
6	Red	Red	+15 V
7	Blue	Blue	TTC
8	Black	Blue	FTC
9	Shield	Blue	TC GND
10	White	Green	TSC
11	Shield	Green	SC GND
12	Black	Green	FSC

## NOTES

---

---

---

---

---

---

---

---

---



181 Bonetti Dr  
San Luis Obispo, CA  
93401 USA  
ph: 805-549-0161  
fax: 805-549-0163  
e-mail: [usl@uslinc.com](mailto:usl@uslinc.com)



1025 Pine Meadows Ct  
Martinez, CA  
94553 USA  
ph: 925-372-7603  
fax: 925-372-7658  
e-mail: [bacp2000@aol.com](mailto:bacp2000@aol.com)