

# Film-Tech

The information contained in this Adobe Acrobat pdf file is provided at your own risk and good judgment.

These manuals are designed to facilitate the exchange of information related to cinema projection and film handling, with no warranties nor obligations from the authors, for qualified field service engineers.

If you are not a qualified technician, please make no adjustments to anything you may read about in these Adobe manual downloads.

[www.film-tech.com](http://www.film-tech.com)

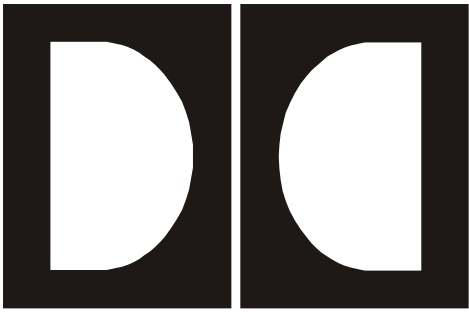

**Dolby**<sup>®</sup>

**Cat. No. 702**

**Digital Soundhead  
Installation Instructions**

DPN 91839

Issue 1

---

## **Dolby Laboratories, Inc.**

### **Corporate Headquarters**

**Dolby Laboratories, Inc.**  
100 Potrero Avenue  
San Francisco, CA 94103-4813  
**Telephone** 415-558-0200  
**Fax** 415-863-1373  
[www.dolby.com](http://www.dolby.com)

### **European Headquarters**

**Dolby Laboratories**  
Wootton Bassett  
Wiltshire, SN4 8QJ, England  
**Telephone** (44) 1793-842100  
**Fax** (44) 1793-842101

## Table of Contents

List of Figures .....	iv
List of Tables.....	iv
Regulatory Notices.....	v
FCC.....	v
Canada.....	v
Europe.....	v
IEC Notices .....	v
Specifications.....	vi
1 Power.....	1
2 Mounting the Digital Soundhead .....	1
2.1 Adapter Plates .....	1
2.2 Accessories .....	1
2.3 Installation .....	2
2.4 Mechanical Alignment.....	4
2.5 Electrical Connections to the Digital Soundhead .....	5
2.6 Checking/Setting LED Brightness.....	6
3 Replacing the LED Assembly .....	6
3.1 Installation .....	6
3.2 Alignment.....	7
4 Making a Custom Video Cable .....	9
5 Adjustments .....	13
5.1 Focus.....	13
5.2 Lateral Adjustment.....	15
5.3 Azimuth Adjustment.....	16
6 Assembly Drawings .....	18

## List of Figures

1	Mounting Hole Pattern.....	2
2	Flat Washer Installation.....	3
3	Flywheel Mounting.....	4
4	Digital Soundhead Adjustments.....	4
5	Video Cable Mounting Assembly.....	5
6	Video Level Adjustment.....	6
7	LED Assembly Mounting Screws.....	7
8	LED Assembly Wiring.....	7
9	LED Assembly Initial Gap Setting.....	7
10	Scope Display of Video Test Point Signal.....	8
11	Adjust LED Assembly for Optimum Video Signal.....	9
12	LED Drive-Current Setting.....	9
13	Lens Set Screw.....	14
14	Oscilloscope Image—Focus Adjustment.....	14
15	Roller Inspection.....	15
16	Cat. No. 1034 CCD Board Lateral Lock Screws.....	15
17	Scope Trace for Lateral Adjustment.....	16
18	Azimuth Adjustment.....	16
19	Cat. No. 702 Expanded View.....	18
20	Cat. No. 702 Rear and Side Views.....	19

## List of Tables

1	Video Cable Wiring.....	10
2	Molex Connector Block Wiring.....	13

## Regulatory Notices

### FCC

This equipment has been tested and found to comply with the limits for a Class A digital device, pursuant to Part 15 of the FCC Rules. These limits are designed to provide reasonable protection against harmful interference when the equipment is operated in a commercial environment. This equipment generates, uses, and can radiate radio frequency energy and, if not installed and used in accordance with this instruction manual, may cause harmful interference to radio communications. Operation of this equipment in a residential area is likely to cause harmful interference in which case the user will be required to correct the interference at his or her own expense.

### Canada

This Class A digital apparatus complies with Canadian ICES-003.

### Europe

This equipment complies with the EMC requirements of EN55103-1 and EN55103-2 when operated in an E2 environment in accordance with this manual.

### IEC Notices

	<p>LED Light  <b>Do not stare into beam</b>                      CLASS 2 LED Product Per EN 60825-1:1996 1mW at 650-680 nm</p>	
	<p>Faisceau de LED  <b>Ne pas rester dans le faisceau</b>                      LED Classe 2 selon EN 60825-1:1996 1 mW à 650-680 nm</p>	
	<p>LED Lichtquelle  <b>Nicht in den Lichtstrahl blicken</b>                      LED der Kategorie 2 entspr. EN 60825-1:1996 1 mW bei 650-680 nm</p>	
	<p>L'indicator e del LED  <b>Non guardare fissamente il raggio</b>                      Prodotto LED classe 2 secondo al EN 60825-1: 1996 1 mW a 650-680 nm</p>	
	<p>La luz LED  <b>No mire fijamente al rayo de luz</b>                      Producto LED clase 2 según el estándar EN 60825-1: 1996 1 mW a 650-680 nm</p>	
	<p>LED ljus  <b>Undvik att titta direkt in i laser strålen</b>                      Klass 2 LED produkt per EN 60825-1:1996 1 mW wid 650-680 nm</p>	
	<p>LED belichting                      Kijk niet in de lichtstraal                      Klasse 2 LED product volgens EN60825-1:1996 1 mW bij 650-680 nm</p>	

## Specifications

### Construction

Die-cast aluminum with matte black finish

### Mounting

The soundhead mounts to the following projectors directly:

Ballantyne Pro 35  
Century 35  
Century JJ (early versions may require an adapter)  
Christie P35  
Simplex 35/70 and 35  
Cinemeccanica V4, V5, V8, and V9

---

**Note:** A Cat. No. 690 Adapter is required to reinstall the Cinemeccanica V5 or V8 upper reel arm on the top of the Cat. No. 702 Digital Soundhead.

---

Adapter mounting plates are available for the following projectors:

Norelco AA-II/Philips DP70: Dolby® Cat. No. 695  
Kinson DP75, FP20, and FP30: Dolby Cat. No. 696

### Signal Connections

A shielded, computer-grade video cable connects the soundhead to the cinema processor; the soundhead ships with a 10-meter (32.8 foot) cable with a 12-pin female connector for connection to the Cat. No. 702 and a 25-pin male D-connector for the processor

### Internal Controls

The soundhead includes a control for adjusting the drive current to the LED

### Accessories

Roller assemblies (35 mm and a combination 35/70 mm) are available for threading film along an optional bypass path. Long video cables for connecting the soundhead are also available:

15-meter (49-foot) cable: Part No. 83237  
30-meter (98 foot) cable: Part No. 83142

### Dimensions and Weight

150 × 175 × 275 mm (5.9 × 6.9 × 10.8 inches)  
Net: 5 kg (11 lb)

### Environmental Conditions

Operating: 0° to 40° C (32° to 104° F)  
Non-operating (storage): 0 to 85°C (32° to 185° F)  
Humidity: 20 to 80% relative humidity, noncondensing

## 1 Power

The Cat. No. 702 Digital Soundhead is powered from the CP650, CP500, or DA20 from the video cable. It is not intended to be connected to a Dolby® DA10.

## 2 Mounting the Digital Soundhead

### 2.1 Adapter Plates

The Cat. No. 702 Digital Soundhead casting has a bolt pattern for several common projector types (the same pattern as the Cat. No. 701), and may be mounted to the following projectors without an adapter plate:

**Ballantyne** Pro 35  
**Century** SA and JJ (early versions may require an adapter)  
**Christie** P35  
**Cinemeccanica** V5, V8, and V9

---

**Note:** A Cat. No. 690 Adapter is required for re-installing the Cinemeccanica V8 upper reel arm to the top of the Cat. No. 702 Digital Soundhead.

---

**Simplex** 35 and 35/70

Adapter mounting plates are available for the following projectors:

**Norelco** AA-II/Philips DP70 Cat. No. 695  
**Kinoton** DP75, FP20, FP30 Cat. No. 696

Additional adapter plates may become available. Contact Dolby Laboratories or your dealer for availability.

### 2.2 Accessories

A roller assembly (Dolby Part Number 83239 for a combination of 35/70 mm film) is available to thread along a bypass path. Refer to the drawings in Section 6 for individual parts that may be used to create a roller assembly for 35 mm film.

A replacement LED/heat sink assembly, Part Number 83308, is available for field installation. See Section 3 of this manual for installation details.



## 2.3 Installation

While the digital soundhead is rugged and reliable, it has been designed and built to precision optical and mechanical tolerances. Handle the unit very carefully.

1. Remove the package of parts from the top of the shipping box.
2. Pull out the plastic bag containing the digital soundhead, and slide it out of the surrounding foam. Place the digital soundhead on a table or bench top, with mounting base down. (The mounting base is the surface with 13 mounting holes.) Figure 1 shows how the mounting holes correspond to bolt patterns for various projectors. This diagram shows the hole pattern as viewed from the top, inside the housing.

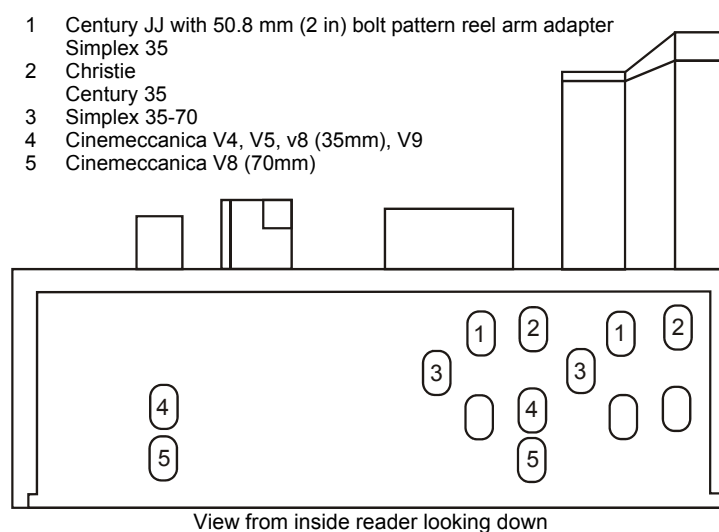

**Figure 1** Mounting Hole Pattern

3. Remove the back cover of the digital soundhead by removing the six screws.
4. Remove the upper reel arm or guide rollers from the projector on which the digital soundhead is to be mounted.
5. If an adapter kit is necessary, mount the adapter plate to the top of the projector. In the case of the Cat. No. 690 adapter kit, the reader attaches to the projector and the adapter plate attaches to the top of the reader.
6. Mount the digital soundhead to the projector body (or adapter plate) matching the appropriate set of bolt holes for the projector type.

If you intend to use **Hole Pattern 1**, then place three 10 mm (3/8 in) flat washers (provided) under the hex head bolt as shown, to provide better wrench access.

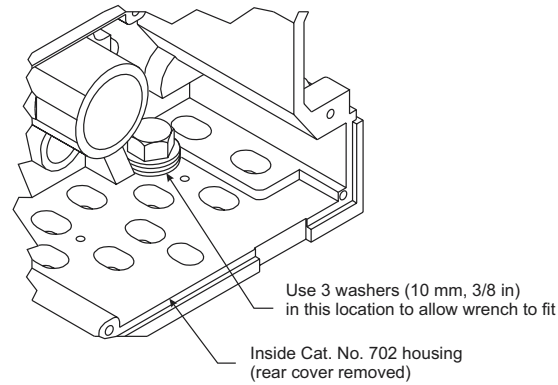

**Figure 2** Flat Washer Installation

---

**Note:** When two Cat. No. 702 Digital Soundheads are mounted for use in a two-projector installation, care must be taken to ensure that the film path lengths between the digital soundhead and the picture gates in the two projectors are identical. The soundhead delay setting in the cinema processor is adjusted for correct synchronization of sound and picture during installation. Since only one adjustment is provided, both projectors must have the same film path length from the digital soundhead to the picture gate.

---

7. Reattach the upper reel arm or guide rollers to the digital soundhead, using an adapter plate if necessary.
8. If desired, route appropriate conduit from the sound rack where the cinema processor is to be installed, terminating the conduit at the end of the digital soundhead. The soundhead has an unthreaded 27 mm (1 1/16 in) diameter hole in a 2 mm plate to accept 25 mm (Europe) conduit adapters or 3/4 in (US) conduit fittings. Be sure to follow all local electrical codes.
9. Remove the shipping collar using the supplied hex wrench, and install the digital soundhead flywheel. Reach around to hold the sound drum to prevent the shaft from sliding out and hitting the LED bracket. The flywheel is packed separately for shipping (see Figure 3). Take care not to lose the spring on the shaft.
10. Replace the cover assembly.

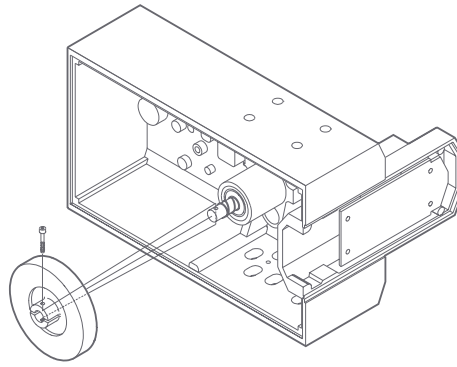
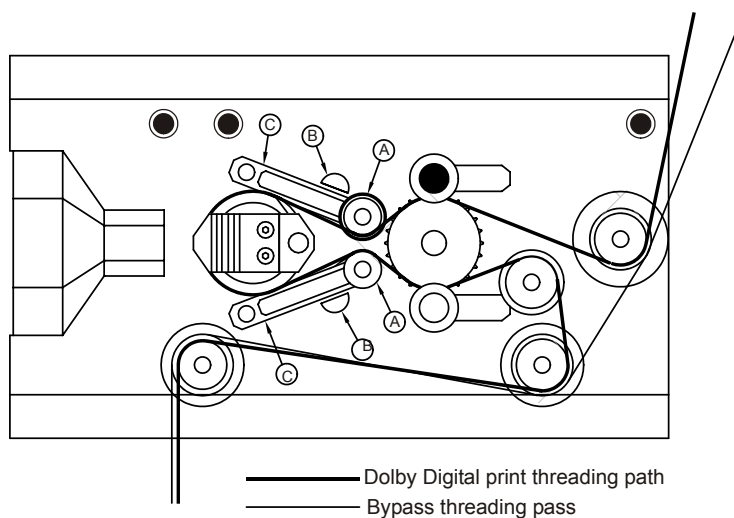

**Figure 3** Flywheel Mounting

## 2.4 Mechanical Alignment

Mechanical alignment of the Cat. No. 702 Digital Soundhead consists of confirming that the film path through the digital soundhead is aligned with the path through the projector.

1. Thread a length of film from a supply reel through the digital soundhead (refer to the threading diagram located on the soundhead), and continue through the projector as for any film.
2. See Figure 4 for the following adjustment instructions. Apply tension so that top and bottom arm rollers (A) are approximately 5 mm (1/4 in) apart. Use the white painted semicircles (B) as a reference point for the alignment of tension arms (C). Make sure that the rollers (A) do not touch.
3. Check for uneven forces on the rollers, or twisting of the film.
4. When the path is aligned, tighten the soundhead mounting bolts and reel arm.



**Figure 4** Digital Soundhead Adjustments

## 2.5 Electrical Connections to the Digital Soundhead

A shielded computer-grade video cable connects the Cat. No. 1034 CCD Board in the digital soundhead to the cinema processor. The standard cable is 10 meters (33 feet) long. Other cable lengths are available:

30 m (100 ft), Dolby Part Number 83142

15 m (50 ft), Dolby Part Number 83237

The video cable is supplied with the hardware shown in Figure 5 pre-assembled at the digital soundhead end of the cable; the cinema processor end of the cable has a male 25-pin D-connector.

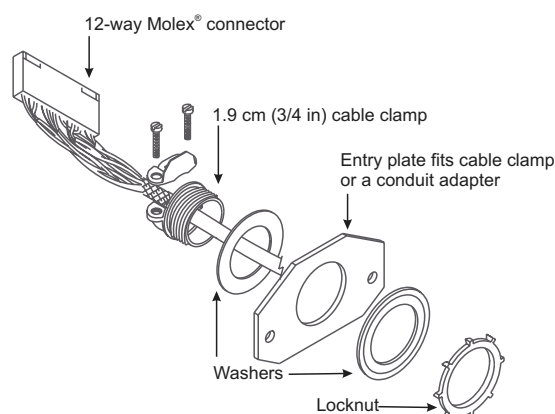

**Figure 5** Video Cable Mounting Assembly

---

**Note:** The cable must be pulled through grounded metal conduit or other shielded path to meet EMI emission standards. If conduit is used for cable routing, then the supplied cable clamp must be removed and replaced with a conduit adapter. Remove the individual wires from the 12-way Molex connector by inserting a small-blade screwdriver into the side hole at each pin position and carefully pulling the wire/contact out of the connector. After inserting the cable through the new conduit adapter, reinstall the wires into the connector. The wiring order is shown in Section 4, steps 11 and 12.

---

Three ferrite blocks are shipped with the Cat. No. 702. If the cable is installed in conduit, place the blocks at the cinema processor end. If you have chosen not to use conduit, then installation of these blocks is essential for preventing excessive RF energy radiation and should be placed near each end of the cable.

---

**Caution:** *Before plugging in the Dolby Digital reader video cable, remove the power from the cinema processor. Failure to do so may result in damage to the CCD board in the Dolby Digital reader.*

---

## 2.6 Checking/Setting LED Brightness

The Cat. No. 702 incorporates a video level measuring circuit and indicator along with a trim pot for adjusting the video level (LED brightness).

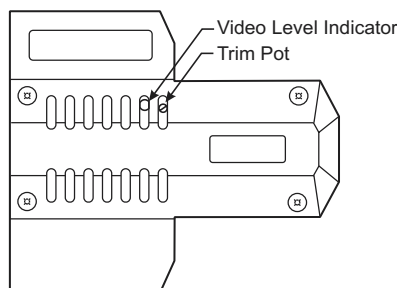

**Figure 6** Video Level Adjustment

With film running, the optimum peak video signal voltage (unobstructed light through the perf hole) is between **4** and **4.5 V**.

The video level indicator colors and video levels are:

Red	Signal too low	<1.5 V
Green	Signal is optimum	1.5 to 4.5 V
Orange	Signal is too high	>4.5 V

With proper LED light output, the indicator is green. To adjust the light level for the optimum signal range, run film and turn the pot clockwise until the indicator turns orange, then turn the indicator counterclockwise until it turns green.

## 3 Replacing the LED Assembly

In normal operation, the LED assembly used in the Cat. No. 702 Digital Soundhead may exhibit gradually reduced light output over the course of its lifetime. If it becomes necessary to replace the LED, follow the procedure outlined below. The LED assembly is Dolby Part No. 83308.

### 3.1 Installation

1. Turn off the Dolby processor.
2. Remove the two screws that mount the LED assembly to the arm.
3. Carefully pull the LED assembly off the pivot pin.

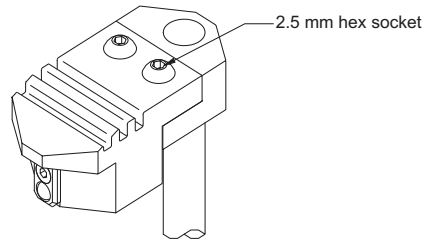

**Figure 7** LED Assembly Mounting Screws

- Carefully turn over the assembly, loosen the two screw terminals, and remove the wires. Note the wire colors and terminal locations.

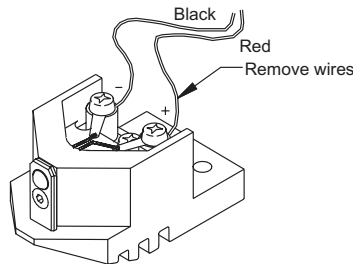

**Figure 8** LED Assembly Wiring

- Attach the wires to the replacement LED assembly using the same wire locations as in the original LED assembly. The wires may require re-stripping since they have been compressed previously, and could be too weak. Inspect the wires carefully before attaching them to the terminals.
- Remount the LED assembly onto the pivot pin. Adjust by tightening the screws slightly with a parallel gap between the rear of the LED assembly and the facing edge of the arm. Using a sheet of paper usually provides the proper clearance.

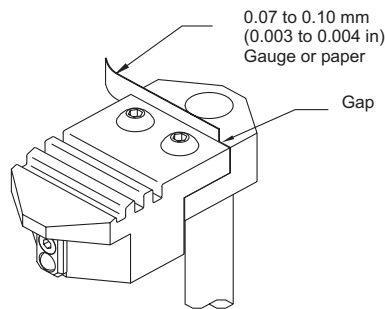

**Figure 9** LED Assembly Initial Gap Setting

## 3.2 Alignment



---

**Warning:** Class 2 LED Product per EN 60825-1:1996. Do not stare into the red LED beam. Do not attempt to view the LED beam with any type of optical device.

---

- Connect an oscilloscope (20 MHz minimum bandwidth) to test points on the

Dolby processor. Some digital oscilloscopes may not be usable for this procedure even if they have the required bandwidth.

- a. Ensure that the probes are 1X and connect scope Channel 1 to the Video test point on the Dolby processor. Connect only this probe's ground to the ground test point.
  - b. Connect scope Channel 2 to the Clamp test point on the Dolby processor.
  - c. Set both channel vertical input sensitivity controls to 1 V/div, DC coupling. Set the vernier to calibrated (usually the inner knob—rotate until it “clicks”).
  - d. Set the horizontal sweep rate to 2  $\mu$ s/div.
  - e. Set the trigger source to Channel 2 and positive polarity.
  - f. Turn on the power to the Dolby processor (i.e., to the Cat. No. 702).
2. Set the oscilloscope display.
    - a. Thread and play a Cat. No. 69T Dolby tone test film loop.
    - b. Display only Channel 2, and adjust the trigger level to lock onto the clamp signal.
    - c. Adjust the horizontal position to line up the inside edge of the left clamp signal with the left screen graticule.
    - d. Adjust the timebase sweep vernier to line up the inside edge of the right clamp signal with the right screen graticule.
    - e. Select Channel 1 display.
    - f. Temporarily switch the scope channel 1 input (video) to GND and adjust the vertical position to coincide with a horizontal screen graticule. This is the 0 V reference baseline.

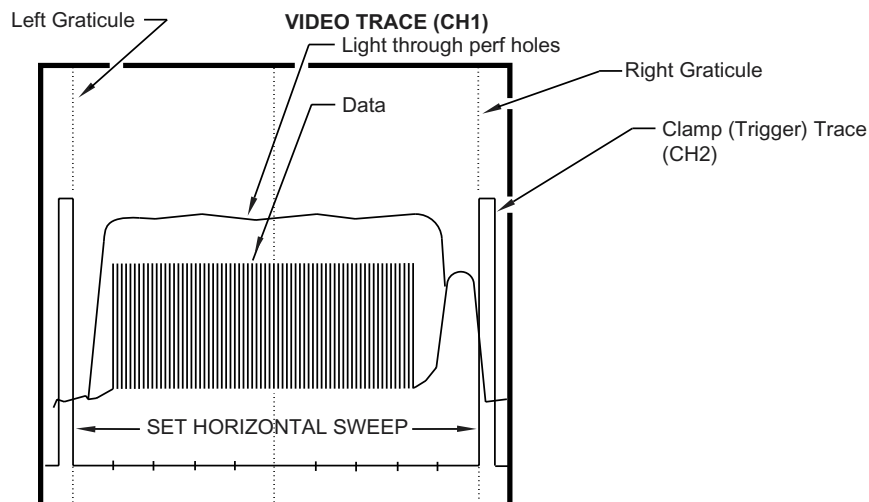

**Figure 10** Scope Display of Video Test Point Signal

3. Adjust the LED Position.

- a. Switch the Channel 1 video input coupling back to DC.

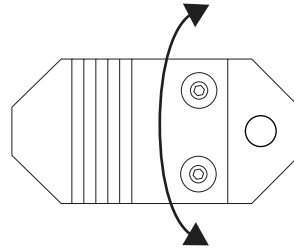

**Figure 11** Adjust LED Assembly for Optimum Video Signal

- b. Loosen the 2.5 mm hex screws and carefully rotate the LED assembly while watching the scope image. Adjust for maximum video signal voltage (unobstructed light through the perf hole) on the **upper trace**. The waveform must be reasonably flat. (It should fit within one scope major division.) Adjust for peak voltage with minimum ripple.
4. Check/set the video signal voltage.

The optimum peak video signal voltage (unobstructed light through the perf hole) is **4 to 4.5 V**, measured from the 0 V reference baseline to the **upper trace**. If necessary, adjust the trim pot on the Cat. No. 702 to achieve the correct video voltage. See Figure 6 for the adjustment location.

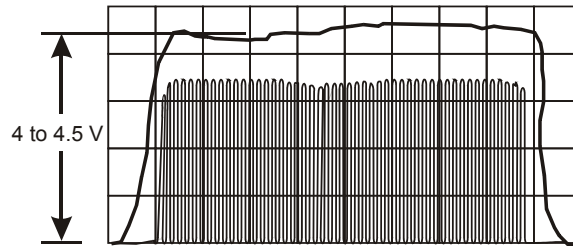

**Figure 12** LED Drive-Current Setting

## 4 Making a Custom Video Cable

The following information is included for use when a cable is being made up on site. The cable should be Belden Datalene<sup>®</sup> 8164, which contains four shielded twisted pairs of computer-grade cable with the shields isolated from each other, plus a 100 percent coverage overall shield. Using other types of cable may result in unsatisfactory operation. The overall shield is necessary to prevent RF interference signals from radiating from the video cable, and to meet government EMI standards. A metal shell **must** be used on the D-connector and the overall shield **must** be grounded to the connector shell to ensure proper operation and compliance with EMI regulations.



**Table 1** Video Cable Wiring

D-Connector Pin Number	Molex Pin Number	Wire Color	Shield Description	Signal Name
1-3				
4	7	Blue	Pair number 3	TTC
5	9	Shield	(Blue shield)	TC GND
6	8	Black		FTC
7	10	White	Pair number 4	TSC
8	11	Shield	(Green shield)	SC GND
9	12	Black		FSC
10-13				
14	1	Black	Pair number 1	Video 0
15	2	Shield	(Red shield)	GND
16	6	Red		+15 V
17	3	Black	Pair number 2	Video 1
18	5	Shield	(Blue shield)	GND
19	4	Green		-15 V
20-25				

1. Strip the back vinyl outer jacket of cable to 7.5 cm (3 in).

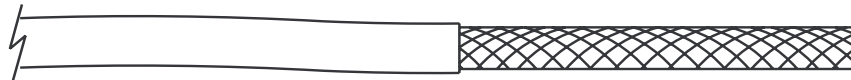

2. Add 12.5 mm (1/2 in) diameter heat-shrink about 6 mm (1/4 in) long near the end of the vinyl outer jacket.

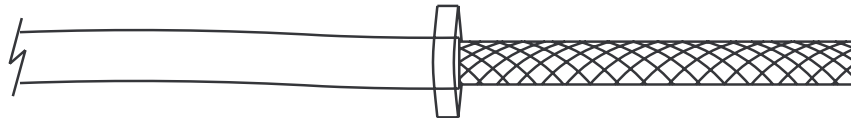

3. Fold the outer shield braid back over the vinyl outer jacket.

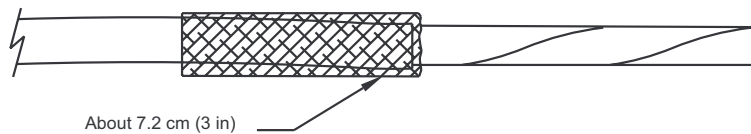

4. Trim back the outer foil shield and plastic cords.

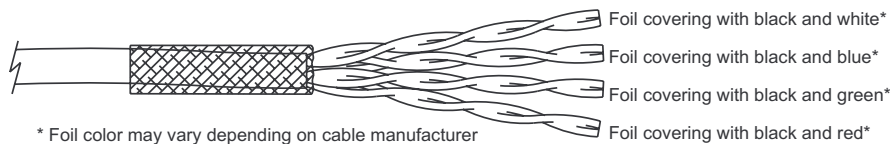

\* Foil color may vary depending on cable manufacturer

5. Install a 7.6 cm (3 in) piece of 12.5 mm (1/2 in) diameter black shrink tubing over the vinyl outer jacket and shield. Leave 19 mm (3/4 in) of the folded back braided shield exposed.

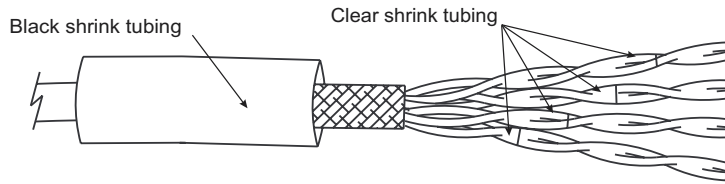

Install 3 mm (1/8 in) clear shrink tubing of the lengths indicated below over the wires.

- 6.1 cm (2 3/8 in) on foil covering with black and white\*
- 5.1 cm (2 in) on foil covering with black and blue\*
- 3 cm (1 3/16 in) on foil covering with black and red\*
- 3.8 cm (1 1/2 in) on foil covering with black and green\*

\* Foil color may vary depending on cable manufacturer.

6. Strip back the foil to the edge of 3 mm (1/8 in) shrink tubing.

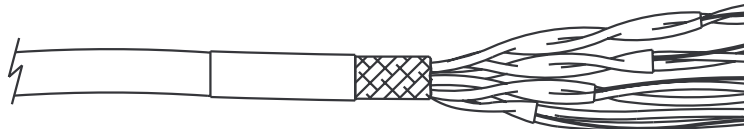

7. Cut the exposed wiring and twisted shield to the lengths indicated below, measuring from the end of the outer cable casing.

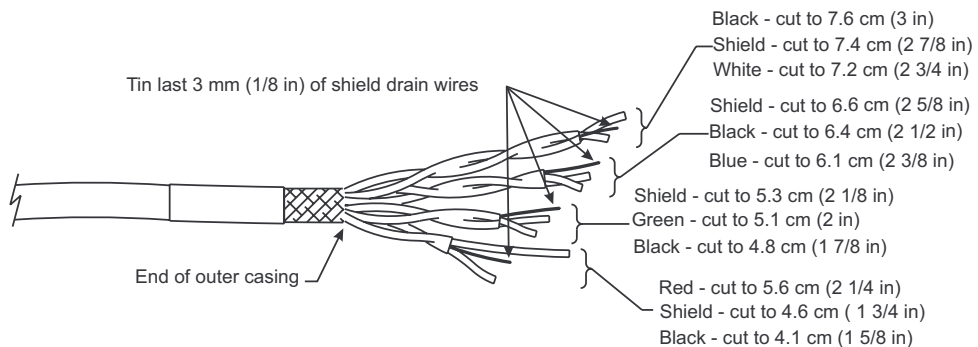

8. Strip the insulated wires back 3 mm (1/8 in).

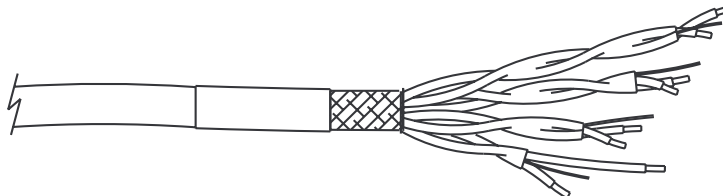

9. Install 1.6 mm (1/16 in) diameter clear shrink tubing over each drain wire of the twisted pairs and heat shrink.

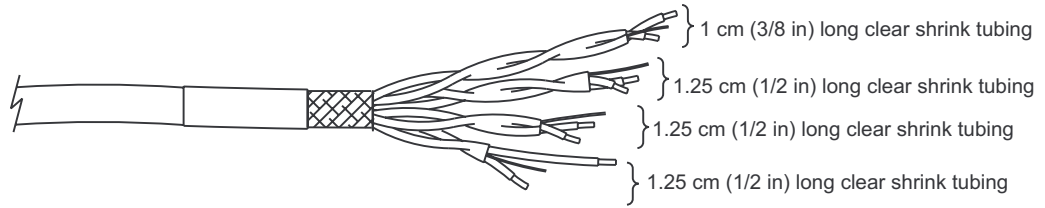

10. Crimp Molex pins onto wires, 12-PL, using Molex tool HTR-2262-20A; then solder the pins to the wires.

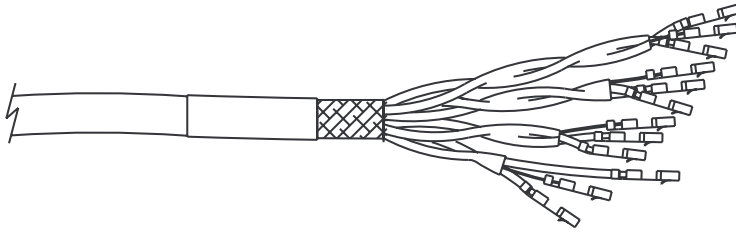

11. Arrange the wires in the following order, bending them 90 degrees, as shown.

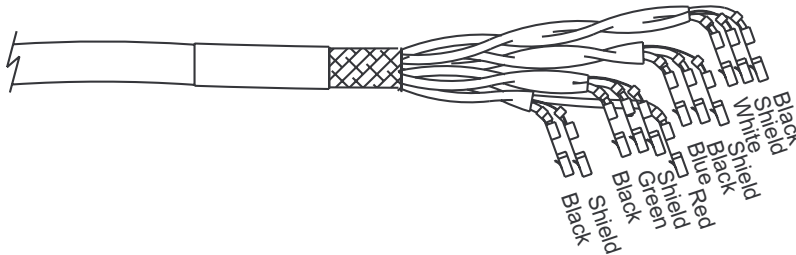

12. Install pins into Molex housing according to wiring table.

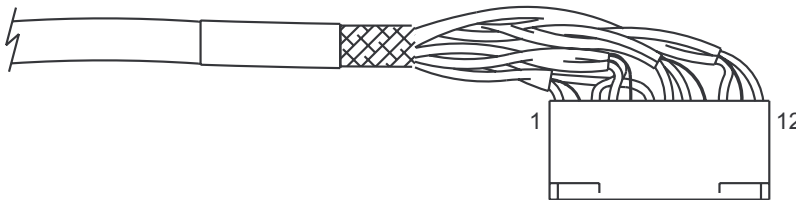

The pins must be inserted in the Molex connector block as shown in Table 2.

---

**Caution:** Perform this operation before plugging the male 25-pin D-connector into the cinema processor. Incorrect placement of pins will damage the CCD board in the digital soundhead and/or the cinema processor.

---

Pin 1 is on the left when the Molex connector is connected to the Cat. No. 1034 CCD board in the Cat. No. 702 Digital Soundhead. This assembly is easiest if you insert the shortest leads first.

**Table 2** Molex Connector Block Wiring

Molex Pin Number	Wire Color	Cable Pair Shield Color	Signal Name
1	Black	Red	Video 0
2	Shield	Red	GND
3	Black	Blue	Video 1
4	Green	Blue	-15 V
5	Shield	Blue	GND
6	Red	Red	+15 V
7	Blue	Blue	TTC
8	Black	Blue	FTC
9	Shield	Blue	TC GND
10	White	Green	TSC
11	Shield	Green	SC GND
12	Black	Green	FSC

The cable clamp that is attached to the Cat. No. 702 cable mounting plate, along with the exposed braid on the video cable, provides an electrical ground path for the shield of the video cable.

This video cable shield may be isolated, if necessary, by loosening the two screws that clamp the video cable shield and installing an insulator around the braided shield, such as a 12.5 mm (1/2 in) diameter piece of heat shrink tubing. It is important to retighten the cable clamp after installing the insulation to provide strain relief for the video cable.

## 5 Adjustments

### 5.1 Focus

The Cat. No. 702 focus is factory-adjusted and should not require readjustment during installation. If the soundhead has become misadjusted, it may be necessary to refocus. It is recommended that both a scope and the Dolby Reader Alignment Software (DRAS) be used together to achieve optimum results. Both methods are described below.

#### Scope Method

1. Use the scope setup described in Section 3.2.
2. Loosen the 2 mm hex socket set screw (located below the lens bore) that holds the lens/CCD assembly in place.

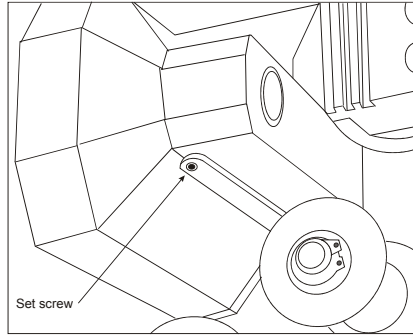

**Figure 13** Lens Set Screw

3. Adjust the objective lens/CCD assembly in the reader head by moving the assembly back and forth. There are two methods for moving the assembly.
  - a. A flat-blade screwdriver inserted in the oval slot above the lens can be twisted to slide the assembly.
  - b. If the CCD circuit board cover is removed, the assembly can be moved back and forth with your thumb and forefinger.

For best focus, the scope pattern should have minimum brightness in the center of the trace. (See Figure 14.) Look for the most “in-focus” display possible, while maintaining minimum brightness inside the envelope. Setting the best focus helps minimize the digital error rate.

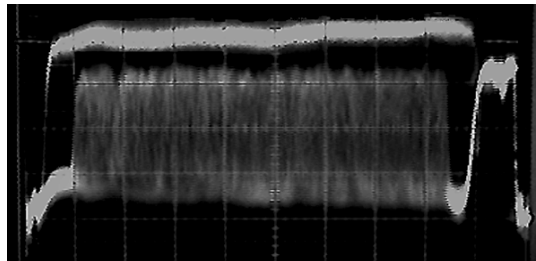

**Figure 14** Oscilloscope Image—Focus Adjustment

4. Retighten the lens-holding screw.

### **Dolby Reader Alignment Software (DRAS) Method**

1. Loosen the 2 mm hex socket set screw (located below the lens bore), which holds the lens/CCD assembly in place (see Figure 13).
2. Adjust the lens/CCD assembly to obtain the highest possible number in the Focus Meter window of the DRAS. (This is a relative number, with no absolute value.)
  - a. A flat-blade screwdriver inserted in the oval slot above the lens can be twisted to slide the assembly.
  - b. If the CCD circuit board cover is removed, the assembly can be moved back and forth with your thumb and forefinger.

3. Retighten the lens-holding screw.

## 5.2 Lateral Adjustment

The lateral position of the CCD board is set at the factory and does not require adjustment during normal use.

Apparent lateral drift is usually caused by a film problem or a worn roller. Use one of the following procedures to eliminate such a film problem or to adjust the CCD board, if necessary. Inspect the lateral film guidance roller (indicated by letter A in Figure 4) for wear, particularly on the flange edges (see Figure 15).

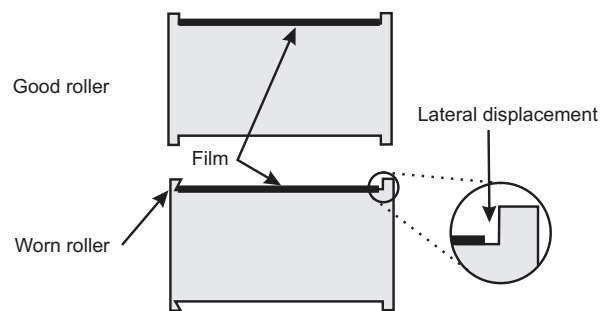

**Figure 15** Roller Inspection

The lateral position of the CCD board must be readjusted if the Cat. No. 1034 is ever replaced.

1. Use the scope setup described in Section 3.2.
2. Loosen the two hex socket screws located on the left side of the Cat. No. 1034 CCD board. (It is not necessary to loosen the two hex socket screws with springs located on the right side of the board.)

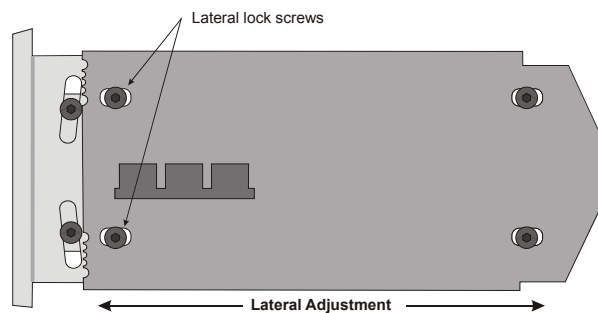

**Figure 16** Cat. No. 1034 CCD Board Lateral Lock Screws

3. Refer to Figure 10. While running any Dolby Digital film, set the oscilloscope to  $2 \mu\text{s}$  per major division. Observe the oscilloscope and move the CCD board left or right until the video envelope (which surrounds the data block) is one minor division offset left of center (see Figure 17).

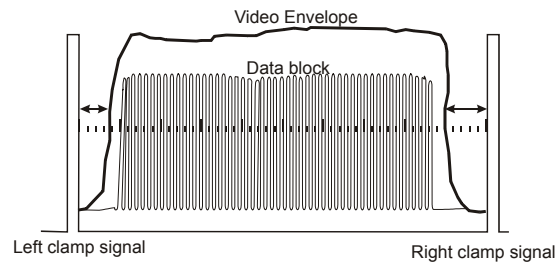

**Figure 17** Scope Trace for Lateral Adjustment

Alternatively, if using the Dolby Reader Alignment Software and the Cat. No. 530 test film, adjust the CCD board until the number in the lateral meter window matches the number that is printed on the test film. Tighten the lateral position lock screws.

### 5.3 Azimuth Adjustment

Normally the azimuth position does not require any adjustment, since it is aligned perfectly at the factory and does not drift. If you notice that the azimuth has changed, verify that the problem is not the film.

If it becomes necessary to adjust the azimuth position of the CCD board, follow this procedure.

1. Loosen the hex socket screw located below the lens bore that holds the lens/CCD assembly in place (see Figure 13).

---

**Note:** Be aware that the lens focus may slip, since the lens assembly locking screw is loose during this adjustment.

---

2. Loosen the two hex socket screws located on the CCD lens plate assembly (immediately to the left of the CCD board lateral hex socket lock screws).

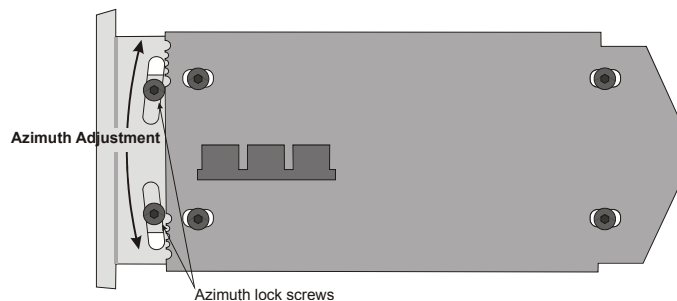

**Figure 18** Azimuth Adjustment

3. Run the Cat. No. 530 test film and observe the azimuth indication in the **Azimuth Meter** window of the Dolby Reader Alignment Software.

4. Swivel the CCD lens plate assembly up or down until the **Azimuth Meter** matches the number written on the Cat. No. 530 test film. Tighten the two CCD lens plate assembly lock screws and the lens assembly lock screw.



## 6 Assembly Drawings

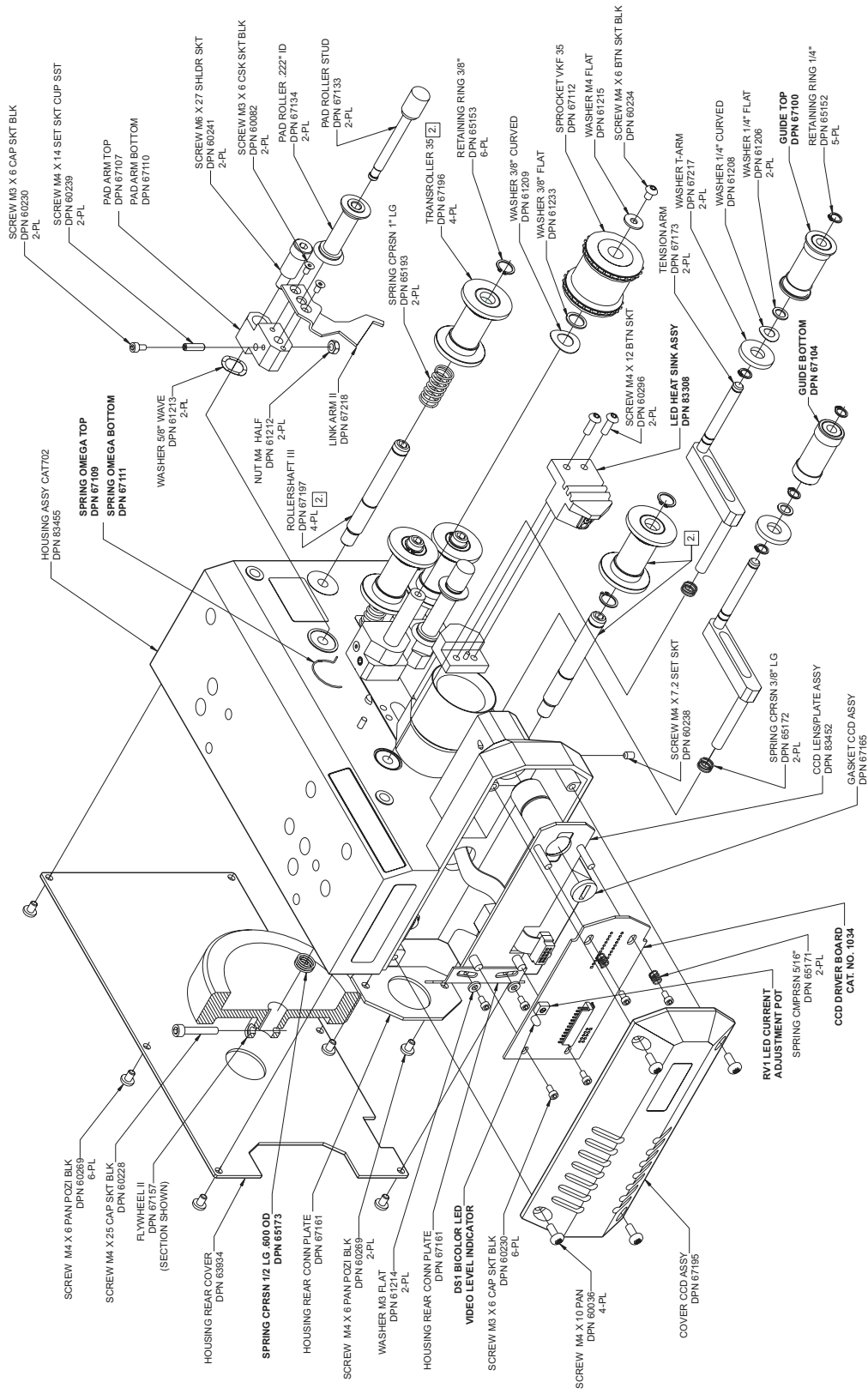
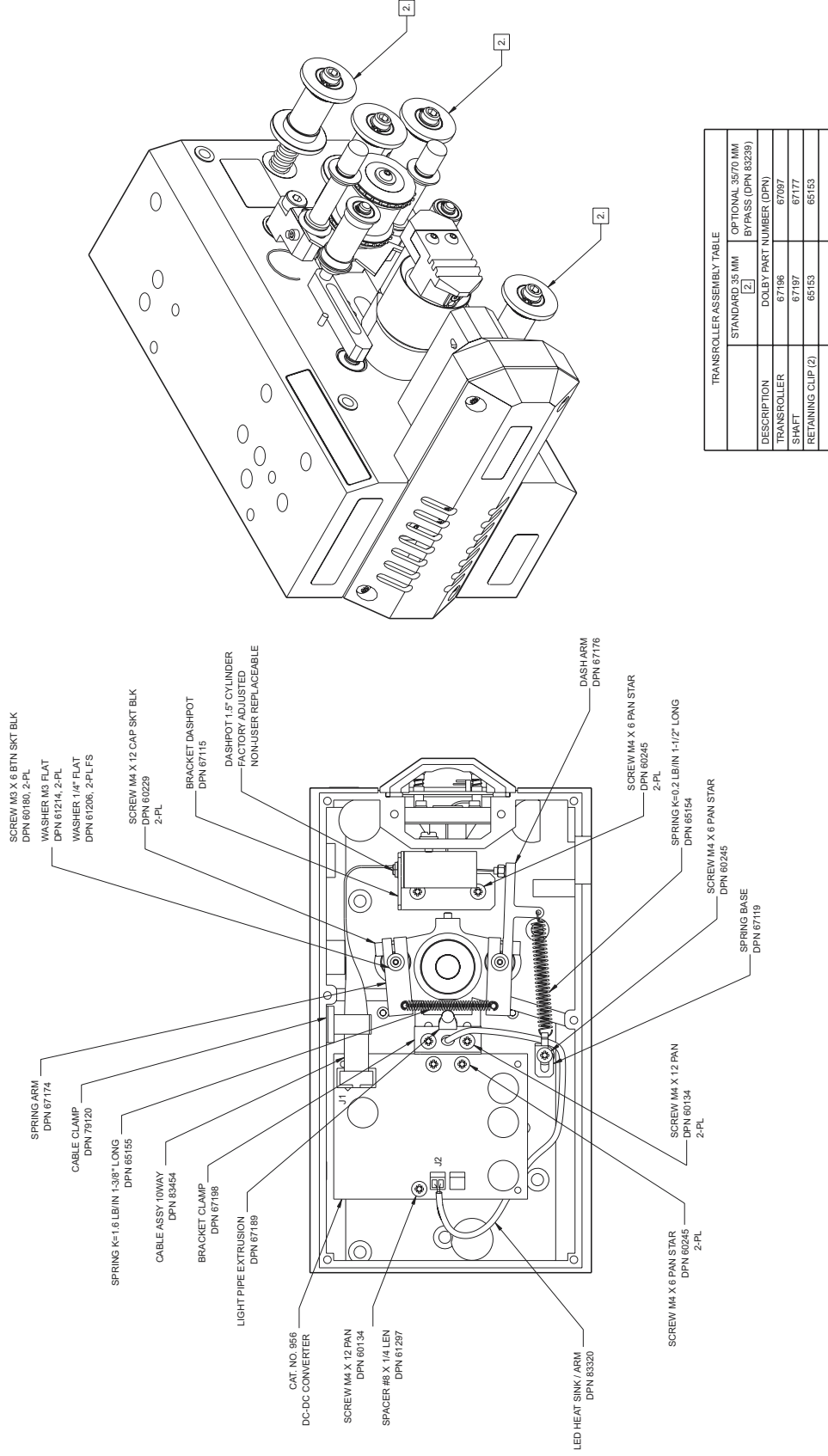

Figure 19 Cat. No. 702 Expanded View

# Dolby Cat. No. 702 Digital Soundhead Installation Instructions



**REAR VIEW**  
REAR COVER, VIDEO CABLE AND PLYWHEEL NOT SHOWN

**Figure 20 Cat. No. 702 Rear and Side Views**