

Film-Tech

The information contained in this Adobe Acrobat pdf file is provided at your own risk and good judgment.

These manuals are designed to facilitate the exchange of information related to cinema projection and film handling, with no warranties nor obligations from the authors, for qualified field service engineers.

If you are not a qualified technician, please make no adjustments to anything you may read about in these Adobe manual downloads

www.film-tech.com

CM-60

Monitor

INSTRUCTION MANUAL



Quality Cinema Products

Ultra*Stereo Labs, Inc. • 181 Bonetti Drive
San Luis Obispo, CA 93401

Telephone 805.549.0161 • e-mail usl@uslinc.com

One Year Limited Warranty



Ultra*Stereo Labs, Inc. warrants that each product manufactured by it will be free from defects in material and workmanship under normal usage for a period of one (1) year after its purchase new from an authorized dealer. Our obligation under this warranty is limited to repairing or replacing any product or component which we are satisfied does not conform with the foregoing warranty and which is returned to our factory, freight paid, or serviced by one of our authorized contractors. The foregoing warranty is exclusive and in lieu of all other warranties, whether expressed or implied. Such warranty shall not apply to any product or component (A) repaired or altered by anyone other than Ultra*Stereo Labs or an authorized service contractor; (B) tampered with or altered in any way or subjected to misuse, negligence or accident or (C) which has been improperly connected, installed or adjusted other than in accordance with Ultra*Stereo Labs instruction.

Ultra*Stereo Labs, Inc.
181 Bonetti Drive
San Luis Obispo, CA 93401 USA
Telephone 805.549.0161
FAX 805.549.0163
e-mail usl@uslinc.com

0399

 **USL, Inc.**
Quality Cinema Products
© 1999 Ultra*Stereo Labs, Inc.
San Luis Obispo, CA, USA.
All Rights Reserved

Table of Contents

Introduction 4

Configuration 6

Installation 11

Specifications 14

Amplifier Pinouts 15

Processor Pinouts 16

CE Approved

Please record the following information for your records:

Model: _____ Serial Number: _____

Date of Purchase: _____ Purchased from: _____

Introduction

Please read this entire manual before commencing your installation.

The Ultra*Stereo CM-60 Projection Booth Monitor has been designed for high performance, ease of use, and years of trouble-free service. Installation and setup of the monitors has been considerably simplified. No special tools are required. The built-in VU meter and test jack give the technician immediate information about the status of the processor and all power amplifiers. All controls necessary for daily operation of the processor are easily accessible on the front panel. The components that make up the CM-60 monitors are of computer grade for reliability. All front panel controls are individually sealed for long life. All Ultra*Stereo equipment has been "burned-in" at the factory for an extended period in order to eliminate the possibility of premature failure. Unpack the unit carefully. If the container has been damaged, thoroughly inspect the equipment to make certain that there is no hidden damage. File a claim immediately with the carrier if any damage is found. Also advise your dealer or the factory.

TOOLS REQUIRED



Trim pot
adjustment
tool



Small slotted
screwdriver

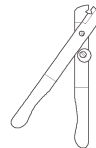

Wire strippers



No. 2 phillips
screwdriver

You will need to supply the following materials:

- Shielded audio cable for connecting the CM-60 to the cinema processor and power amplifier outputs.
- Four 10-32 x 1/2" screws to mount the CM-60 in the audio equipment rack.

FEATURES**The CM-60 monitor has the following standard features:**

- Six-Channel Monitoring - allows you to monitor either the processor or power amplifier outputs to left, center, right, surround left, surround right and subwoofer channels, in any combination via the switch on the front panel (see illustration on pg. 6 - switch 3).
- Input levels from processor and power amplifier can be adjusted independently - no huge level jumps when switching between processor and power amplifiers.
- Bargraph display may be calibrated to the reference level for your theatre – the projectionist can see auditorium levels instantly.
- Designed to work with bi or tri-amplified sound systems to monitor the high, mid and low frequency outputs from the left, center and right channels.

Configuration

CM-60 Front Panel

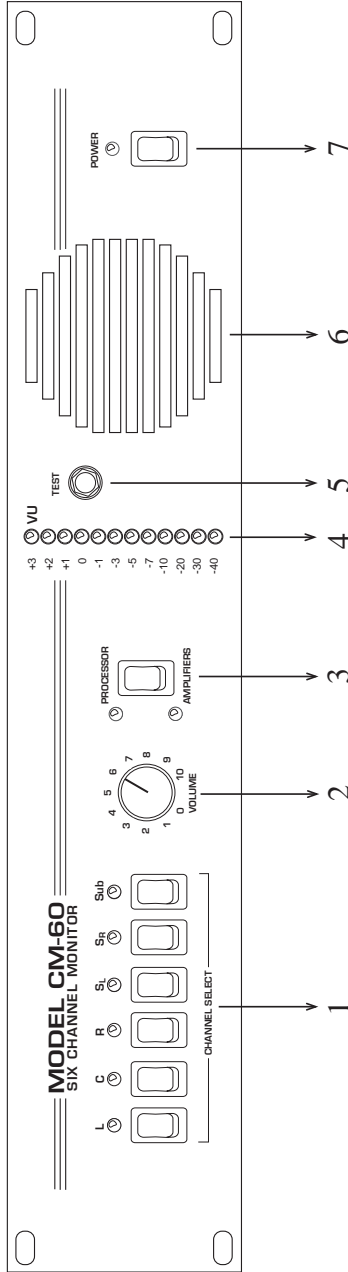

1. **Channel Select Buttons** - pressing a Channel Select button causes the corresponding LED to illuminate, and the signal from that channel to be monitored. Any combination of six channels may be selected.
2. **Volume Control** - controls the volume of the internal or external speaker. The volume control has no effect on VU Bargraph display.
3. **Processor/Amplifier Selector Switch** - selects either the inputs from the cinema processor or power amplifiers for monitoring (see 4, 8 on pg. 8).
4. **VU Bargraph** - displays the level of the selected channels. The VU Bargraph may be calibrated by the rear panel trim adjustment (see 10, pg. 8). The VU Bargraph operates independently of the volume control (2).
5. **Test Jack** - permits monitoring of the audio output of the CM-60. Inserting a mono 1/4" phone plug here disables the internal speaker and routes the audio output to the Test Jack. Do not connect any device here with less than 8 Ω impedance.
6. **Internal Speaker**
7. **Power Switch**

CM-60 Rear Panel

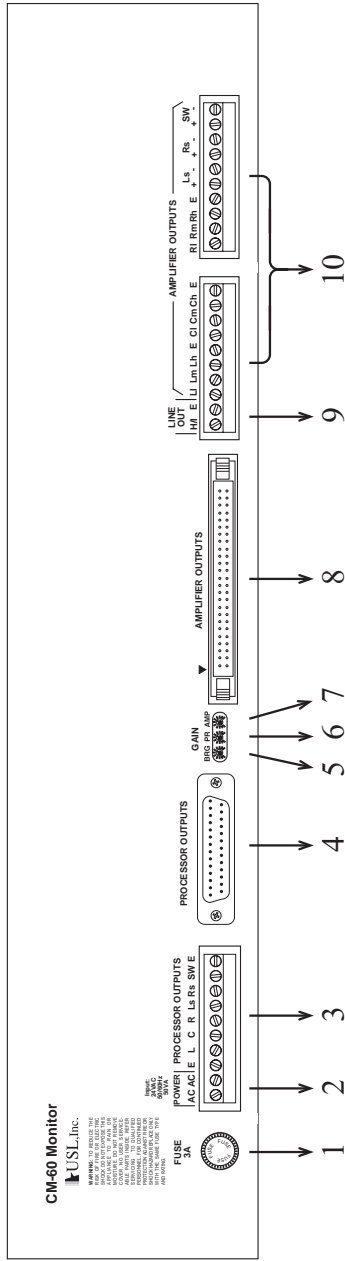

1. **Main Fuse** - 3 Amp
2. **AC Input** - 24V
3. **Processor Outputs** - connect these terminals to the cinema processor outputs corresponding to left, center, right, left and right surrounds, and subwoofer.
4. **Processor Outputs** - the processor outputs may be connected through a 25-pin D-sub connector. (See Processor Output Connection Pinout table, pg. 16.)
5. **Bargraph Level** - this trimpot adjusts the sensitivity of the front panel VU Bargraph meter.
6. **Processor Level** - this trimpot adjusts the level of the input lines coming from the processor.
7. **Amplifier Level** - this trimpot adjusts the level of the input lines coming from the power amplifiers.
8. **Amplifier Outputs** - the amplifier outputs may be connected through a standard 50-conductor flat cable and connector to J2. (See Amplifier Output Connection Pinout table, pg. 15).
9. **Line Out** - the left, center and right channel signals from the processors are summed from amplifiers and fed to this terminal.
10. **Amplifier Outputs** - connect these terminals to the power amplifier speaker outputs corresponding to left, center, right, left and right surrounds, and subwoofer. Left, center and right channels have high and low frequency inputs to use with bi-amplified systems.

CM-60 Hookup Diagram

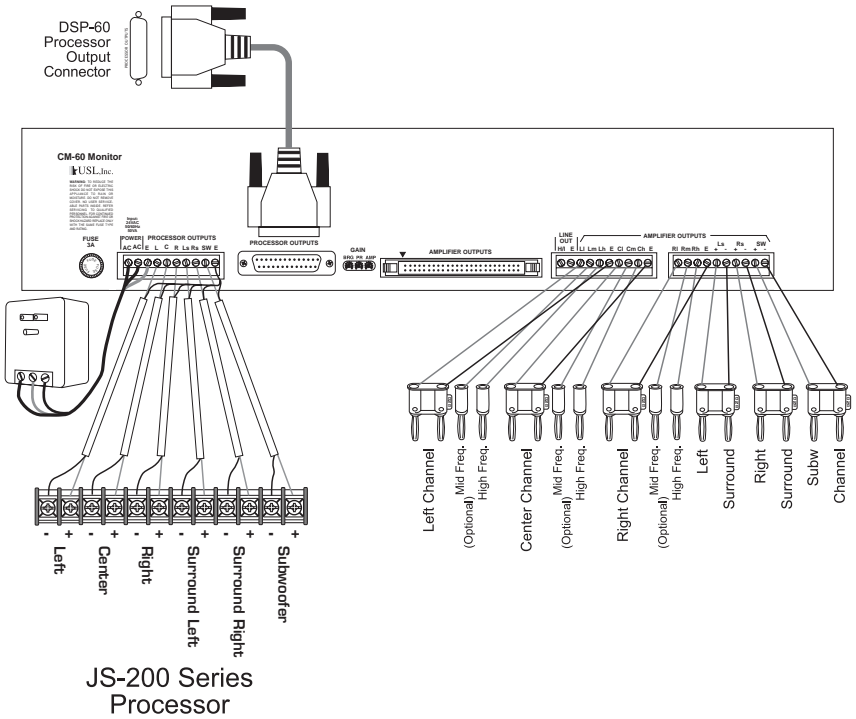

Installation

Mount the CM-60

The ideal place for the CM-60 Monitor is in the sound rack or projector console between the stereo processor and power amplifiers. The terminal blocks on the rear of the CM-60 are designed to facilitate the application of stripped and tinned wire leads and are pluggable for easy service and trouble shooting.

Monitor Hookup

1. Power: Use 18AWG wire provided to connect the wall transformer to the CM-60.

2. Processor Outputs: Use shielded wire to connect the line-level outputs from the cinema processor to the CM-60. There is one terminal for the "hot" signal from each channel, and one common "E" (ground) terminal. The CM-60 also has a DB-25 computer style connector that matches the Ultra*Stereo DSP-60 processor, as well as many other processors. When the DB-25 connector is used, the processor output connections on the terminal block should be left unconnected.

3. Amplifier Outputs: Use any suitable wire to connect the power amplifier's speaker outputs to the "Amplifier Outputs" terminals on the CM-60. The CM-60 has three inputs for each of the three front channels for use with bi-amplified or tri-amplified systems. For systems that are not bi or tri-amplified, use only the low frequency inputs (Ll, Cl, Rl). For bi-amplified systems use only the low frequency (Ll, Cl, Rl) and high frequency (Lh, Ch, Rh) inputs. Unused inputs can be left unconnected. The surround and subwoofer inputs are balanced and may be used with bridged or other non-grounded amp systems. The amplifiers may also be connected to the CM-60 using a 50-conductor ribbon cable and interface boards at each amplifier. Contact the factory for more information on this convenient system.

4. Crossover monitoring: The CM-60 also has line-level inputs for monitoring the biamp crossovers. These connections are available only on the DB25 connector. There are no screw terminals. The three front channels have low and high frequency inputs. The DSP-60 (and perhaps others) will simultaneously transmit the full-range audio signal and the high and low frequency crossover outputs. It may be necessary therefore to disable the full range signal so only the post-crossover audio is being monitored. There are jumpers inside the CM-60 for this purpose (see pg. 13).

5. Split Surround Processors: For connection to split-surround processors such as the Ultra*Stereo models JS-230, connect the left and right processor outputs to the CM-60 surround left and surround right inputs, respectively.

6. Line Output: For convenient connections to Ultra*Phonic or other hearing impaired systems, the CM-60 has a line-level output that combines the left, center, and right processor outputs.

Setting Levels

Run a pink noise test film such as Ultra*Stereo Type 1 or Dolby® Cat. 69. Set the processor main fader and power amplifier levels so the house speakers are playing back at the normal listening level. Set the Processor/Amplifier switch to Processor and note the reading on the front panel bargraph meter. Next, set the Processor/Amplifier switch to Amplifier, and adjust the Amplifier Level trimpot on the rear of the unit for the same bargraph reading.

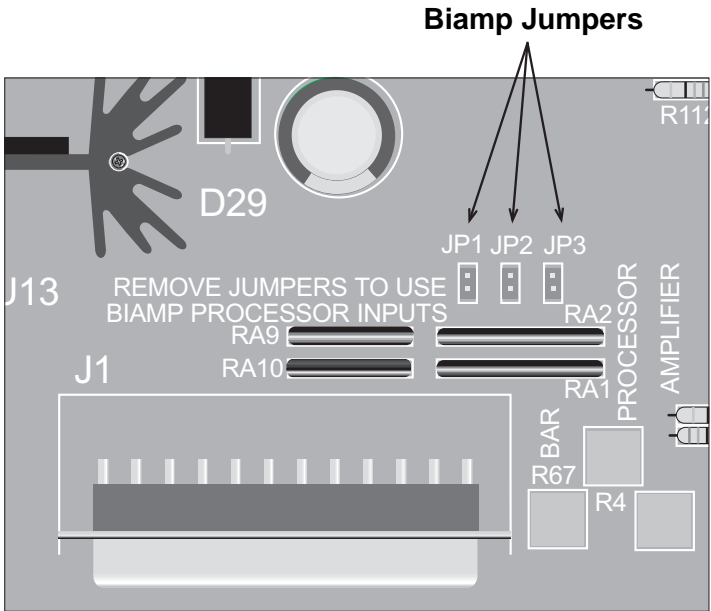

Specifications

Inputs

Processor: Six inputs corresponding to left, center, right, surround left, surround right and subwoofer. Input impedance is 10k Ω .

Power Amp: Twelve (12) inputs corresponding to left hi, mid and lo, center hi, mid & lo, right hi, mid and lo, surround left, surround right and subwoofer. Input impedance is greater than 50k Ω . Surround and subwoofer inputs are balanced allowing use with bridged amplifiers.

Controls

Front Panel: Individual push button switches for each input channel toggle on and off so that channels may be monitored in any combination. An LED indicator illuminates when the corresponding channel is selected. A volume control sets the speaker output level and works independently of the front panel VU bargraph meter. A push-button switch with corresponding LED switches monitoring between the Processor and Amplifier inputs. A 14-segment bargraph VU Meter indicates the input level from -40 to +3 VU.

Rear Panel: Three trimpots adjust the processor, amplifier and VU meter input levels.

Power Requirements

24 VAC from external wall mount transformer.

100 and 240 V transformers are available.

Construction

The CM-60 Monitor is constructed of steel to minimize hum pickup and noise radiation. The overall size of the unit is 3.72" x 19" x 8". The CM-60 is designed to mount in a standard rack frame or cabinet.

CM-60

Weight: 8 lbs. 10 oz.

Shipping weight: 12 lbs.

Amplifier Output Connector Pinout

Pin#	Function
1	Left Low
2	GND
3	Left Mid
4	GND
5	Left High
6	GND
7	Center Low
8	GND
9	Center Mid
10	GND
11	Center High
12	GND
13	Right Low
14	GND
15	Right Mid
16	GND
17	Right High
18	GND
19	Left Surr +
20	GND
21	Left Surr -
22	GND
23	Right Surr +
24	GND
25	Right Surr -
26	GND
27	Subwoofer +
28	GND
29	Subwoofer -
30	GND
31	N/C
32	GND
33	N/C
34	GND
35	N/C
36	GND
37	N/C
38	GND
39	N/C
40	GND
41	N/C
42	GND
43	N/C
44	GND
45	N/C
46	GND
47	N/C
48	GND
49	N/C
50	GND

Processor Output Connector Pinout

Pin #	Function
1	GND
2	Left
3	N/C
4	N/C
5	Center
6	N/C
7	N/C
8	Right
9	N/C
10	GND
11	GND
12	GND
13	N/C
14	GND
15	Left LF
16	Left HF
17	GND
18	Right LF
19	Right HF
20	GND
21	Center LF
22	Center HF
23	Surr L
24	Surr R
25	Sub

Ultra*Stereo Labs, Inc.
181 Bonetti Drive
San Luis Obispo, CA 93401 USA
Telephone 805.549.0161
FAX 805.549.0163
e-mail usl@uslinc.com

 **USL, Inc.**
Quality Cinema Products
© 1996, 1998 Ultra*Stereo Labs, Inc.
San Luis Obispo, CA, USA.
All Rights Reserved