

FILM-TECH

THE INFORMATION CONTAINED IN THIS ADOBE ACROBAT PDF FILE IS PROVIDED AT YOUR OWN RISK AND GOOD JUDGMENT.

THESE MANUALS ARE DESIGNED TO FACILITATE THE EXCHANGE OF INFORMATION RELATED TO CINEMA PROJECTION AND FILM HANDLING, WITH NO WARRANTIES NOR OBLIGATIONS FROM THE AUTHORS, FOR QUALIFIED FIELD SERVICE ENGINEERS.

IF YOU ARE NOT A QUALIFIED TECHNICIAN, PLEASE MAKE NO ADJUSTMENTS TO ANYTHING YOU MAY READ ABOUT IN THESE ADOBE MANUAL DOWNLOADS.

WWW.FILM-TECH.COM

'STOPPING AND RE-STARTING THE PROJECTOR/S AND THE ALARM SYSTEM.'

It is important that one fully appreciates how the Alarm System works, and how it affects the restarting of the projector/s when an alarm condition arises.

Firstly, the Alarm System does not come into circuit until the time delay following the operation of the Zippa has expired after which either a film break, or the film running slow, or failure of the light in the Xenon Lantern, will cause the Alarm System to operate.

When this happens a total shutdown occurs and the internal buzzer sounds. This can be stopped by operating the 'CANCEL' button, after which the projector can be re-started.

To do this one must appreciate that before the shutdown occurred, a Start Proj. Function must have been in the memory. For example, if the Start Proj. Function was called for on Line No.10, when that was actioned from a mark on the film, the projector started and the Line Indicator moved on to Line 11.

This means to say that all the time the projector was running the Start Projector Function was still in the memory, indeed that was what kept the projector running.

Now we have a film break and everything shuts down, BUT the Start Projector Function is still in the memory, so that as far as the memory is concerned, the projector is still running.

It necessarily follows that if we now try to start the Proj. again by returning to the previous line number on which the Start Projector function was called - then nothing will happen.

It is therefore necessary to remove the original instruction from the memory, and then read the instruction again.

So please remember BEFORE trying to restart a projector following a shutdown in which the alarm has sounded, it is necessary to move the equipment on to a line which has a STOP PROJECTOR function on it, and for that line to be read, before returning to the original line to restart the projector.

We will now consider what happens when the film runs out on the end of a reel.

Firstly, a single projector installation. With a single proj. set up the alarm system is introduced in the normal way after the Zippa has operated, and UNLESS a 'Stop Projector' function is called for in the memory on the last line of the programme, the Alarm WILL SOUND when the film runs out, as the equipment cannot without the 'Stop Projector' function being called, know the difference between the film breaking in the middle of a reel and the film running out at the end of the reel.

This means that one can please oneself whether the Alarm sounds on the end of the reel or not. If one wishes the Alarm to sound on the end of the reel, on the last line of the programme one uses a spare function to operate Zippa Down, the film runs out and the projector and Xenon are stopped by the action of the stop roller, and the Alarms sound when this happens.

If on the other hand one does NOT wish for the Alarm to sound, then a 'Stop Projector' function should be programmed on the last line, in which case the projector and Xenon will stop when that line is read, the Alarms will NOT sound, and the tail leader is run out of the projector by manual means.

Now for a two projector operation with change-overs. Under these conditions, when a change-over takes place, the film runs out of the outgoing projector which is stopped by the action of the stop roller, and the Alarm DOES NOT sound. What happens in theory is that the equipment derives information from the run up sequence of the incoming projector to inhibit the Alarm from operating on the outgoing one.

So no Alarms sound under change-over conditions.

However, when we come to the last reel there is no change-over condition, in fact it is just like a single machine operation, therefore the Alarm WILL sound on the run out of the last reel, unless a 'Stop Projector' function is used in the same way as for a single projector installation.

No matter whether if its a single or two projector installation, its a good idea to practice both ways of stopping the projector and one soon decides which method is to be preferred.

A final word on stopping projectors. Remember if the projector is stopped by the Red 'Stop Left or Stop Right' Push Buttons on the front door of the equipment, it is still necessary to go on to a Stop Projector function in the memory and for that Stop Projector function to be read, before the proj. is to be started. No matter how the projector is stopped, whether it be through a film break/light failure Alarm condition, or by the operation of the Stop Buttons, it is always necessary to remove the original Start Projector instruction from the memory by reading a Stop Projector line before the projector can be re-started.

THE ONLY EXCEPTION TO THIS RULE IS WHEN THE PROJECTOR IS STOPPED BY A STOP PROJECTOR FUNCTION FROM THE MEMORY.

TECHNICAL INFORMATION SHEET No.4.
'PROGRAMMING THE EQUIPMENT'

Before starting to consider programming it is essential that one is fully aware of what exactly the buttons on the front do, and do not do.

Looking at the equipment with the front door closed, here is a list of the buttons and detail of what they do. Starting from left to right:-

FORWARD(START) Moves the NEXT LINE NUMBER INDICATOR FORWARD. If pressed quickly will only move the indicator forward one line, for example from line number 21 to 22. If the finger is kept on the button, it will gain speed and rip through the entire 256 lines at the rate of knots.

REVERSE. Does exactly the same as the FORWARD Button, but moves the line numbers backward. BUT WITH A SUBTLE DIFFERENCE, but more of this later.

ISOLATE. Probably the most important button of all, and one which carries out several functions. Note that the centre of the button carries a red L.E.D. to indicate whether the equipments memory is isolated from the action of pulses being received or not. In other words, if the Isolate is on, no function on any line in the memory will be actioned.

So far so good, but now imagine the film running and for some reason a pulse is missed from the film. Lets make it good by pressing the FORWARD button quickly. But none of us are perfect so we accidentally keep our finger on the FORWARD button a bit too long! Disaster? No way, because when the FORWARD button is pressed, if the finger is kept on too long, it will only read the next line, after which it automatically goes on to ISOLATE without one having to touch the ISOLATE button. This is an inbuilt safety feature to guard against the button not being quickly pushed. If however, the button is quickly pushed, the NEXT LINE NUMBER INDICATOR will only move on one line, and the Isolate L.E.D. will not light.

Now let us suppose that the same thing happens again; we miss a mark on the film and we try to make it up by pressing the FORWARD button just as before, but this time we really screw it up and press the REVERSE button by mistake! Not to worry, when the REVERSE button is pressed the equipment will instantly go on ISOLATE, and it WILL NOT read the previous line, or for that matter any line in the memory.

One can now see the relationship between the FORWARD, REVERSE and ISOLATE buttons also the red L.E.D. Indicator in the centre of the ISOLATE button, which can of course light up without one actually pressing the button itself.

In addition to the foregoing, the ISOLATE button when pressed also isolates the action of the SELF PULSE facility also that of the DIGITAL INTERVAL TIME CLOCK.

This can be very handy, for if the equipment was self pulsing, say to provide a few secs. break between pictures, not long enough to warrant using the time clock, then if we press the ISOLATE button the action of self pulsing will immediately be frozen solid, and the equipment will stay on that line until the ISOLATE button is pressed again and the red L.E.D. indicator goes out, when the SELF PULSE will pick up where it left off and self pulsing will be resumed just as though we had not stopped it.

The same thing goes for the DIGITAL INTERVAL TIME CLOCK, if this is running down, timing out an interval we can stop it dead in its tracks by pressing the ISOLATE button - the red L.E.D. Indicator lights up - the time clock stops running down, and everything stays that way until we again press the ISOLATE button, the red L.E.D. goes out and the time clock resumes running down from where it was frozen.

CANCEL ALARM.

This does just what it says, if either the film breaks or runs slow, or if the light fails in the Xenon Lantern, the Alarm System will be activated with the effect that all the internal relays related to the projector run up sequence will de-energise, everything folds up and the internal buzzer will pulse sound. This is cancelled out by pressing the CANCEL ALARM button.

CLEAR.

This clears any functions that we may have entered into the PROGRAMME INPUT, it wipes that line of the programme input clear.

GO.

This is used to address the PROGRAMME INPUT prior to transferring the information into the memory. Each push of the button causes a red LED to light up on the PROGRAMME INPUT. However, we may not require a whole row of functions to happen on that line, and that's where the NO-GO button comes into the act.

NO-GO.

Causes a 'NOTHING' to be entered into the memory and here it must be explained that in digital logic there is no such thing as nothing. Nothing is a thing in its own right. Therefore the memory can never be empty - it can only be full of nothing, which amounts to the same thing except that we have to enter nothing in the memory, and this we do by pressing the NO-GO button.

Now assuming the the Programme input is clear, if we press the GO button a red LED will light on Column 24. If we now press the NO-GO button once the red LED will leave Column 24 and move down to 23. If we continue to press the NO-GO button it will continue to move down to Col.1 after which it will roll of the end of line and the PROGRAMME INPUT will now be clear and vacant. Right now its full of nothing. It will now be seen that information is entered into the PROGRAMME INPUT serially from right to left and if we now experement with building up a line using the GO and NO-GO buttons all will soon be made clear as to how this is done. Remember however that we are only addressing the programme input, we are not putting information into the memory, and if at any time one makes a mistake, the whole can be erased by pressing the CLEAR button, and one starts on that line all over again.

ENTER.

This transfers information that has been built up on any line on the PROGRAMME INPUT and when this button is pushed the same information will now be seen on both halves of the twin bar graph indicator. One would press the CLEAR button which would remove the information from the PROGRAMME INPUT, leaving this clear, and the only display would be the NEXT PRESENTATION, indicating that this was now in the memory on that line ready for use.

STORE.

This stores any time set on the DIGITAL INTERVAL TIME CLOCK in the memory. It can only be erased completely by entering 0000 (Four Zero's or nothing) into the memory, or by selecting a different time and entering that into the memory in its place. The clock memory has a capacity of 59mins 59secs.

PLUS.

This moves the clock forward and increases the time of the interval.

MINUS.

This moves the clock backwards and de-creases the time of the interval. Be careful when running time down with this button. If one 'overshoots' and it rips down to zero, then if

..... anything is programmed to happen on that line it will be actioned.

RESET. This instantly RESETS the clock to Zero but what is on the line at that point of time will not be actioned. The equipment only goes to line I and stays there.

We will now consider the programming in greater detail, but before so doing must allocate columns to specific functions. We know that Columns I,2,3, 22,23 and 24 are already allocated and are operated by the internal logic, so we now content ourselves with allocating the remainder to the external functions.

For this exercise we will assume a SINGLE PROJ. INSTALLATION in an average theatre with one set of curtains, two position, 'Scope and Flat masking, two sets of lights one of which we can call the Coloured Lights, the other the White Lights or Houselights together with Non-Sync/Tape Deck Sound.

Here is a suggested allocation:-

COLUMN I. - Start Projector(Left.)
" 2. - NOT USED.
" 3. - Stop Projector.
" 4. - Curtains Open.
" 5. - Curtains Close.
" 6. - Masking 'Scope.
" 7. - Masking Flat.
" 8. - Tape Deck Start.
" 9. - Non-Sync/Tape Sound On.
" 10. - Coloured Lights Up.
" 11. - Coloured Lights Down.
" 12. - White Lights Up.
" 13. - White Lights Down.
" 14. - If a twin coil Zippa is fitted to the projector, this column can be used for Zippa closed.

Columns 15-21 with this example are spare and can be used in either the pulsed or latched mode to operate any additional functions that may be required.

Now set the NEXT LINE NUMBER INDICATOR to Line I, press the ISOLATE button so the Red LED lights and we will now programme the opening of the show on Line I.

Assuming that our first picture is in 'Scope, to open the show the following functions would be required.

Col.5 - Curtains Close.
" 6 - Masking 'Scope.
" 8 - Tape Deck Start.
" 9 - Non-Sync/Tape Sound On.
" 10 - Coloured Lights Up.
" 12 - White Lights Up.
" 24 - Start Interval Timer.

We have introduced the Interval Time Clock on this line so that it will provide the time interval between the theatre doors opening and the actual start of the picture. If the doors open at 1.10pm. and the show starts at 1.30pm. then we set the interval timer to 20mins., NOT FORGETTING to press the STORE button after we have set the time, so that it is entered into the clock memory.

If we forget the actual functions and only think of the Column numbers it will be seen that on line I we require numbers 5,6,8,9,10,12 and 24. If we now take the lowest number, in this case 5, and press the GO button when we want a number, and the NO GO number when we do not, and if we count the numbers as we go along, it all soon falls into place.

In this fashion. Count out loud as you press the buttons starting with the GO button.

Like this:-

<u>PRESS.</u>	<u>COUNT.</u>
GO.	5.
GO.	6.
NO GO.	7.
GO.	8.
GO.	9.
GO.	10.
NO GO.	11.
GO.	12.
NO GO.	13.
NO GO.	14.
NO GO.	15.
NO GO.	16.
NO GO.	17.
NO GO.	18.
NO GO.	19.
NO GO.	20.
NO GO.	21.
NO GO.	22.
NO GO.	23.
GO	24.

The programme input should now show a Red LED alight in Columns 5,6,8,9,10,12 & 24, which is just what we wanted. Now press the CLEAR button and the whole display will disappear. Try doing this several times and its amazing how quick it becomes to enter information into the programme input. The idea of counting is, of course, to stop us overshooting and the whole lot rolling of the end of line I.

Now press the Enter button and the same display will now be seen on the NEXT PRESENTATION indicator telling us this information has been entered into the memory on Line I. Now press the CLEAR button which removes the information from the Programme Input and only leaves us with the information displayed on the NEXT PRESENTATION INDICATOR.

As the Programme Input Indicator is now blank and shows it is full of 'NOTHING'S' if we now decide to change our mind and alter what is now showing on the NEXT PRESENTATION INDICATOR, all we do is to press ENTER, we shall now replace what is in the memory with all the 'Nothings' that are in the Programme Input, so that now BOTH displays are blank and we can start all over again and re-programme Line I as we wish.

Practice doing this several times and all will be clear.

Now SWITCH OFF THE UNIT. When switching ON again the unit will only flash up line I and will instantly move on to Line 2, which at this moment of time is blank because we have not programmed Line 2 yet.

This switching ON and OFF exercise is to demonstrate what happens on the opening of the show. If an external time clock switches on the mains supply to the unit it will READ LINE I, and what is on Line I will be actioned, and No.2 will instantly appear as the Next Line Number.

In our example Columns 5,6,8,9,10,12 and 24 would be actioned. HOWEVER in our case that has not happened because we have the equipment on ISOLATE, so Line I has not been actioned.

We are now at the stage where the Next Line Number showing is 2 and Line 2 is blank ready for us to programme it. Our next move is to do so and get the show going on Line 2.

To do this we require the following functions:-

- Column I - Start Projector(left).
- 8 - Tape Deck Start. (Remember it must be programmed on every line for as long as we want to keep it going)
- 9 - Non/Sync/Tape Sound ON. The above also applies to this function, or for any other latched relay.
- I3 - White Lights Down.

Our pressing and counting act for this line will now be as follows:-

<u>PRESS.</u>	<u>COUNT.</u>
GO.	I.
NO GO.	2.
NO GO.	3.
NO GO.	4.
NO GO.	5.
NO GO.	6.
NO GO.	7.
GO.	8.
GO.	9.
NO GO.	IO.
NO GO.	II.
NO GO.	I2.
GO.	I3.
NO GO.	I4.
NO GO.	I5.
NO GO.	I6.
NO GO.	I7.
NO GO.	I8.
NO GO.	I9.
NO GO.	20.
NO GO.	2I.
NO GO.	22.
NO GO.	23.
NO GO.	24.

It would seem that when pressing that last batch of NO GO's all we were doing was to move the whole display down into its correct position. This is true, but we were also entering all those 'Nothings' into the Input where we do not require the function to occur.

We next require a mark on the film to pulse the equipment on to the next line so we can lower the coloured lights and switch over from Non-Sync to film sound. The mark should be placed so we just catch the beginning of the sound track.

Meantime we will programme Line 3. Now how we do this depends on our tape deck. We want to switch from Non-Sync to film sound without any wow or run down from the tape deck and as the relay actually switching the sound over from Tape to Film is inside the unit and free of any lagging capacity effect, it should de-energise instantly, and beat the run down effect of the Tape Deck. We shall therefore switch both these functions off, or to express it better, dispense with them, for remember there are no Columns for Non-Sync or Tape Deck Off as such, they are either in the memory in which case they are 'ON', or they are not in the memory in which case they are OFF.

So to kill the Non-Sync sound and the Tape Deck on this line all we have to do is to omit them.

.....

That being the case Line 3 will look like this:-

COLUMN II. All on its own.

Our pressing and counting act being very simple, in fact there is no need to count, simply press the GO button once, then keep pressing the NO GO button until the red bar of light rests in Column II.

It is hoped that all the foregoing will assist in enabling one to understand how the equipment is programmed. Regretably that's all it can do - a few minutes of playing with the equipment is worth 50 pages or more on how to do it. Fairly easy to do, but hellish to describe exactly how to do it.

Assuming now the whole programme has been marked up and the programme inserted in the memory. We now wish to return to line I, and to do so, on the last line that was read from a mark on the film, we have to programme in on that line a RESET function on Column 22. This will cause the equipment to return to Line I but UNLIKE the condition that we experience on switch on, Line I will not be read. Line I will simply come up and stay displayed as the next presentation, nothing having worked on that line - not even the time clock.

If we require Line I to be actioned we have to also programme in a 'Self Pulse' function in addition to the Reset function on our last Line of the complete programme.

Imagine our last line of the programme was Line 30, then this would probably comprise the following if we wish the equipment to return to Line I and for Line I to be actioned:-

Column	3	-	Stop Projector.	
"	9	-	Non-Sync/Tape Sound On.	(Tape Deck Started on previous line.)
"	12	-	White Lights Up.	(Coloured Lights Up " " ")
"	22	-	Reset to Line I.	
"	23	-	Self Pulse.	

With this programmed of the finishing line of the complete performance, the equipment will reset to Line I, that line will be read and actioned and the time clock will run down until it reaches zero after which Line 2 will be actioned.

There are, of course a variety of different effects one can achieve by applying the Self Pulse and Time Clock functions, indeed one can do this with the whole system, but it is hoped that these few notes on programming will serve as an introduction.

A few final thoughts and do's and don'ts with regard to the programming:-

- (1) Remember what you see displayed as the NEXT Presentation is really just that. What is happening now is over and done with and was on the previous line in the memory.
- (2) Never have a Self Pulse and the Time Clock called on the same line in the memory. This sends the equipment bananas as we now have two time scales working against each other, that the clock was set for, and the set 5 secs time scale of the Self Pulse. In any event the Self Pulse is always going to win provided the time clock is set for a greater time than 5 secs. What happens is that when the Self Pulse 5 sec. time scale is up, it moves the equipment on to the next line and stops the Time Clock which by this action has been removed from the memory.
- (3) If you run the Time Clock down to Zero by pressing the Minus button whatever is indicated on the Next Presentation Indicator will be actioned.
- (4) If you RESET the clock while it is running whatever is indicated on the Next Presentation Indicator will NOT be actioned.
- (5) When switching off, always leave a few secs. before switching on again. Pulse trains fly around in the 'Chips' in ~~no~~ seconds, and it's nice to

CINEMATION 2000.
Technical Information Sheet No.3.

THE MEMORY - LINES AND COLUMNS.

The memory has a 6K plus bit capability, in actual fact 6144 bits are used in this memory, and these are presented as 256 lines operating 24 columns. The columns can be thought of also as the functions one wishes to operate.

The memory has a battery back up of approx 18 months duration with the equipment switched off, the battery being charged all the time the equipment is switched on.

Some of the 24 columns operate what are known as 'DEDICATED FUNCTIONS', meaning that these columns can only be used to operate the functions determined by the internal logic, the other columns are known as NON-DEDICATED FUNCTIONS meaning that they can be used to operate any external function we desire.

Here is the list of the DEDICATED FUNCTIONS and the Column Numbers that operate them. The column numbers are engraved in white on the front red bezel of the equipment.

- COLUMN No.1 - START LEFT PROJECTOR.
- COLUMN No.2. - START RIGHT PROJECTOR.
- COLUMN No.3. - STOP BOTH PROJECTORS.
- COLUMN No.22 - RESET TO LINE No.1.
- COLUMN No.23 - SELF PULSE (At 5sec. intervals)
- COLUMN No.24 - START DIGITAL INTERVAL TIME CLOCK.

The remainder of the Columns can be used to operate any external functions to be determined on installation.

IMPORTANT NOTE. When the equipment is used on a single proj. installation it is set up before despatch for the single projector to be considered the LEFT PROJECTOR. The Right Projector Column No.2 not being used except on a two projector installation. This is very important, please refer to Technical Information Sheet No.2 which underlines this point.

The information in the memory is displayed on the bottom half of the twin Bar Graph Indicator and is engraved 'NEXT PRESENTATION'. The top half of the twin Bar Graph Indicator is engraved 'Program Input' and is used solely to programme the equipment.

The actual programming procedure is covered by Technical Information Sheet No.4, a good study of which is strongly recommended before programming is started.

'RELAY ALLOCATION.'

The Cinemation 2000 equipment contains a total of 34 Relays of which 15 are operated by the internal logic operating the two projector Start Run Up Sequences, one for the Left Proj. and one for the Right Proj.

They are as follows:-

Left Proj. Run Up Sequence.

RL.I Left Rectifier/Platter Start.
RL.2 Left Projector Motor Start Pulsed.)
RL.3 Left Projector Motor Start Latched.) Operate together at same point of time.
RL.4 Left Xenon Strike Pulsed.
RL.5 Left Zippa Open Pulsed.)
RL.6 Left Exciter Lamp On Latched.) All 3 relays operate together at same point
RL.7 Left Projector Run Latched.) of time.

Right Proj. Run Up Sequence.

RL.9 Right Rectifier/Platter Start.
RL.I0 Right Projector Motor Start Pulsed.)
RL.II Right Projector Motor Start Latched.) Operate together at same point of time.
RL.I2 Right Xenon Strike Pulsed.
RL.I3 Right Zippa Open Pulsed.)
RL.I4 Right Exciter Lamp On Latched.) All 3 relays operate together at same point
RL.I5 Right Projector Run Latched.) of time.

Each projector run up sequence contains an adjustable time delay between the separate relay operations, the whole sequence being as follows:-

Immediately on receipt of a film pulse reading a 'Start Left' instruction in the memory on Column I -

(A) RL.I Left Rectifier/Platter relay energises and latches.

Then after an adjustable time delay -

(B) RL.2 Left Proj. Motor Start relay pulses and at the same time RL.3 relay energises and latches.

Then after an adjustable time delay -

(C) RL.4 Left Xenon Strike relay pulses.

Then after an adjustable time delay -

(D) RL.5 Left Zippa Open relay pulses and at the same time RL.6 Left Exciter Lamp On relay energises and latches, and at the same time RL.7 Left Proj. Run relay energises and latches.

Then after an adjustable time delay -

(E) The internal logic introduces the Alarm System function which brings into circuit the Light Detector Cell and the Stop Roller/Device.

The operation of the Right Projector Run Up Sequence is identical to the Left.

It will now be seen that there are 4 adjustable time delays related to each projector run up sequence, a total of 8.

The 8 adjustable time delays are actioned by 8 hexadecimal coded switches, 4 operating the left proj. functions, and 4 for the right projector. They are in fact 16 position rotary switches coded 0-9 and A-F. Each position on the switch gives an additional 1 sec. delay before the next function on the run up sequence takes place.

On despatch the switches are set on position No.2, which seems about right for a typical leader run up time before the actual picture starts.

The switches are altered by inserting a small screwdriver and rotating the centre part of the switch. These switches have click stop positions to aid their setting.

Looking into the equipment with the front door open, the layout of the switches and the delays they control are shown below.

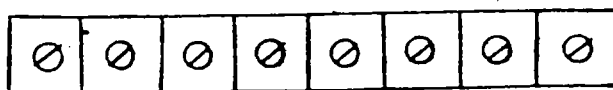

- Adjusts time delay before Left Proj. Motor Start Relay works.
- Adjusts time delay before Left Xenon Strike Relay Pulses.
- Adjusts time delay before Left Zippa Relay Pulses.
- Adjusts time delay before Left Alarm System is introduced.
- Adjusts time delay before Right Proj. Motor Start Relay works.
- Adjusts time delay before Right Xenon Strike Relay Pulses.
- Adjusts time delay before Right Zippa Relay Pulses.
- Adjusts time delay before Right Alarm System is introduced.

Note that there is no time delay associated with the left and right Rectifier/Platter relays. These energise immediately the pulse is received from the mark on the film.

If one now counts up the number of relays detailed for the left and right proj. run up sequences it will be seen that only 14 relays can be accounted for, yet we say earlier that 15 relays are used. The answer is that the 15th. relay is RL.8, the Alarm Relay, which pulses in sympathy with the internal buzzer when alarm conditions prevail.

The remaining 19 relays, known as the 'non-dedicated' relays, because one can use them to control any external function one desires, can be made to either 'pulse' or 'latch at will. This selection is carried out by the position that a row of 20 small slider switches on the logic board are placed in. They should be placed in the DOWN position to pulse operate the relays, and in the UP position to latch the relays. Note that the relays when operated in the latched mode only remain latched for as long as they are called for in the memory. They have to be entered on every line in the memory for as long as one wishes for them to remain energised. Immediately they do not appear on any line they de-energise.

These switches are multi-coloured, and are in banks of 5, there being a total of 20 switches, of which only 19 are used, the spare switch being the extreme left hand switch when looking at the logic panel board. The columns in the memory to which the switches relate, also the relays they control are noted below.

S.	R.	O.	Y.	B.	R.	O.	Y.	B.	R.	O.	Y.	B.	R.	O.	Y.	B.	R.	O.	Y.
SPARE.	COL.22. - RL.34.	COL.21. - RL.33.	COL.20. - RL.32.	COL.19. - RL.31.	COL.18. - RL.30.	COL.17. - RL.29.	COL.16. - RL.28.	COL.15. - RL.27.	COL.14. - RL.26.	COL.13. - RL.25.	COL.12. - RL.24.	COL.11. - RL.23.	COL.10. - RL.22.	COL.9. - RL.21.	COL.8. - RL.20.	COL.7. - RL.19.	COL.6. - RL.18.	COL.5. - RL.17.	COL.4. - RL.16.

Note that each bank of four switches is unpluggable and after setting or altering them it is a good idea to give them a gentle push to make sure they are firmly in their holders.

It should be noted that as well as pulsing (or latching) RL.34, Column 22 is also the 'RESET' Column, meaning that when that column is called for in the memory, in addition to pulsing or latching RL.34, it also resets the equipment back to Line 1.

In practice it is thought probable that only two functions will be required to be latched, those being the 'Tape Deck Start' and the 'Non-Sync/Tape Deck Sound On'. Note however that the equipment is despatched with all the switches in the DOWN PULSE OPERATED MODE, so it will be necessary on installation to move the switches selected for these functions into the UP latched position.

On switching on the mains switch, a reset pulse is applied to the line number counters (IC4 & IC5) which set the address bus to zero. IC2 clocks the data from IC3 into the display driver IC1, and since the address bus is initially set to zero the "Next Line Number" displayed is 1 because of the link (a) option.

The data is entered via the "Go" & "No-Go" buttons and is entered serially into IC18, IC17 & IC16 (via IC's 49 & 52). The outputs of IC's 18, 17 & 16 present parallel data to the memory IC's 10, 11, 12, 13, 14 & 15 and the bar L.E.D. drivers IC's 19, 20, & 21. The bar L.E.D. (Program Input) drivers are permanently enabled to show the data being entered. On pressing the "ENTER" button, this parallel data is written into the memory IC's. The memory IC's are powered by the +5V line when the unit is on, and by the battery B1 when the unit is switched off, so that programmes are not lost when the mains are not applied.

The parallel outputs from the memory IC's are fed into latches IC's 7, 8 & 9. This data is clocked into the latches by the rising edge of the film pulse. The outputs of these latches govern the operation of the relays. The first 3 channels (IC7 pins 2, 5 & 6 respectively) control the start up sequences of the projectors, while the last 3 channels (IC9 pins 15, 16 & 19) control the auto-reset, self-pulse & timer respectively. Channels 4 through to 21 inclusive are fed through "AND" gates, IC's 56, 61, 62, 63 & 64. Associated with these IC's are a row of switches which enable the associated relays to be either pulsed or continuous. The pulsed duration is 1 second. The outputs of the memory are also fed to IC's 22, 23, & 24 which drive the "Next Presentation" bar L.E.D.'s.

The next line number is incremented by the operation of the forward (start) button, & this signal is transmitted via IC's 55, 53 & 51 before applying the clock pulse to the line number counters. A steady pressure on the forward button enables the line number to be rapidly incremented. This is accomplished by the action of IC6, 53, 51 & VT1. IC6 also provides a pulse in this condition to trigger the isolate flip-flop IC58.

When the isolate flip-flop has been triggered either by a rapid increment of the forward line number, REV. line number or the isolate button itself, all succeeding film pulses are blocked preventing data from the memory being latched into IC's 7, 8 & 9.

The self-pulses are generated using IC's 25, 26, 45 & 48 which produce 5 second pulses i.e. line number is advanced by 1 every 5 seconds. IC79 enables or disables the self pulses, and is reset by the isolate switch.

The film pulses are fed to IC46 via resistors R22 & R23. Upon the application of film pulses the output of IC46 triggers a flip-flop, wired as a 1 second monostable, IC50. R18 & C9 form the timing components of this monostable and the \bar{C} output operates the film pulse L.E.D. The film pulses are then "ORED" with the outputs of the timer and the self-pulse, in IC49.

Cont'd.....

The timer is loaded when called by the program, the loading action is performed by VT7, IC47, IC37, IC61 & IC31. The time is stored in the timer memory IC31 by first incrementing and/or decrementing the timer using the buttons 'PLUS' & 'MINUS' until the correct time is acquired & 'stored' by the operation of the 'STORE' button. The store button forces the data in IC50 to a Logic '1' which is then clocked by the action of segment drive D4 and enables IC61 to produce write pulses for the memory. The contents of the timer driver registers, IC27, are then written into memory. This memory also has battery back-up. When the timer is called into operation and after the driver registers have been updated from its memory, IC46 removes the reset of IC29 allowing 1 second pulses to be fed via IC44 to timer driver clock input which then starts counting down to zero. When the timer driver reaches zero, the zero output goes low. This falling edge is inverted in IC44 and passes through IC45 to be "ORED" with the self-pulse output in IC48, the output of IC48 then fires monostable IC76 to give a 1 second pulse which is then "ORED" with the film-pulse (IC69).

The action of the increment button, decrement button, self-pulse, timer pulse & film-pulses is to increment the address counters and latch the 'Next Presentation' data to the relay drivers.

All internal timing pulses are generated by a crystal controlled oscillator IC30. IC30 is an oscillator/divider - the oscillator runs at 4.194304 MHz. Two basic frequencies are derived from this, namely 262.144 KHz & 4096 Hz. The 262.144 KHz signal is used for updating the 'next line No' display, by providing a clock to IC2. The 4096 Hz signal is commonly divided by 2^{12} to give 1 second pulses, where required e.g. IC25 for self-pulses, IC29 for timer clock, IC's 33 & 38 for counting delays for projector start-up sequences.

The projector start sequence:- description applies to Left Hand Projector with Right Hand Projector (RHP) IC's shown in brackets.

Channel 1 & 2 outputs from IC7 clock a logic '1' through IC59 (IC59 serves both left and right) to fire L1 and/or R1 relays, and presets delay counters IC34 (IC39), IC35 (IC40), IC36 (IC41) & IC37 (IC42) with the contents of SW1 (SW5), SW2 (SW6), SW3 (SW7) SW4 (SW8) respectively and resets IC33 (38) to give 1 second pulses for the delay counters, IC34 (39) then counts down to zero and gives a pulse to trigger IC66 (69) which in turn drives L2 (R2) & L3 (R3) relays, also IC35 (IC40) is enabled by IC72 (IC73). IC35 (IC40) then counts down to zero and gives a pulse to trigger IC67 (70) which in turn drives L4 (R4) & L5 (R5), also IC36 (41) is enabled by IC72 (73). IC36 (41) then counts down to zero and gives a pulse to trigger IC68 (71) which in turn drives L6 (R6) & L7 (R7), also IC37 (42) is enabled by IC72 (73). IC37 (42) counts down to zero and enables IC51 which then enables IC75 to accept Lamp Fail or Film breakage detectors. IC48 & 52 'OR' the L.F. & F.B. detectors before presenting data to IC75. If either L.F. or F.B. detectors signal a fault then IC75 output triggers the alarm circuits via IC60 & resets all

engaged relays involved with the projector start & run via IC60. The presence of an alarm signal triggers IC58 which drives VT8 enabling the piezo buzzer and the alarm relay. The 'cancel alarm' button resets flip-flop IC38 and stops the buzzer and disables the alarm relay.

PICTURE CHANGE OVER MODIFICATION
REMOVE WIRES #'S 3 & 4 FROM RELAY RL-5
TERMINALS 5 & 6

WIRE #3 WILL NOW CONNECT TO RL-6
TERMINAL #7

WIRE #4 WILL NOW CONNECT RL-14 TERMINAL #7

ADD JUMPER WIRE FROM RL-6 TERMINAL #8
TO RL-14 TERMINAL #4

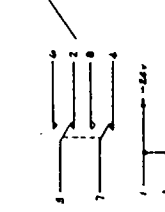
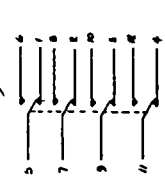
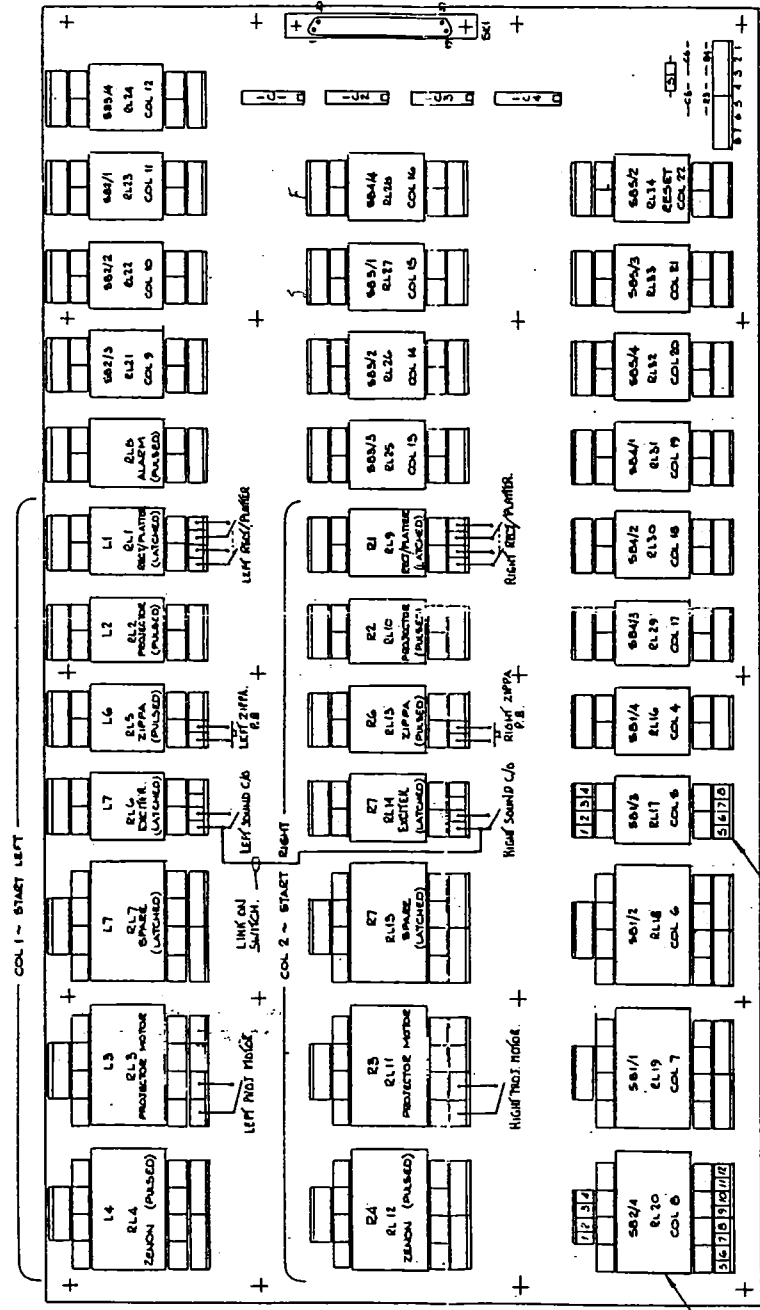

Relay Board Assy FPC-1

RELAY BOARD

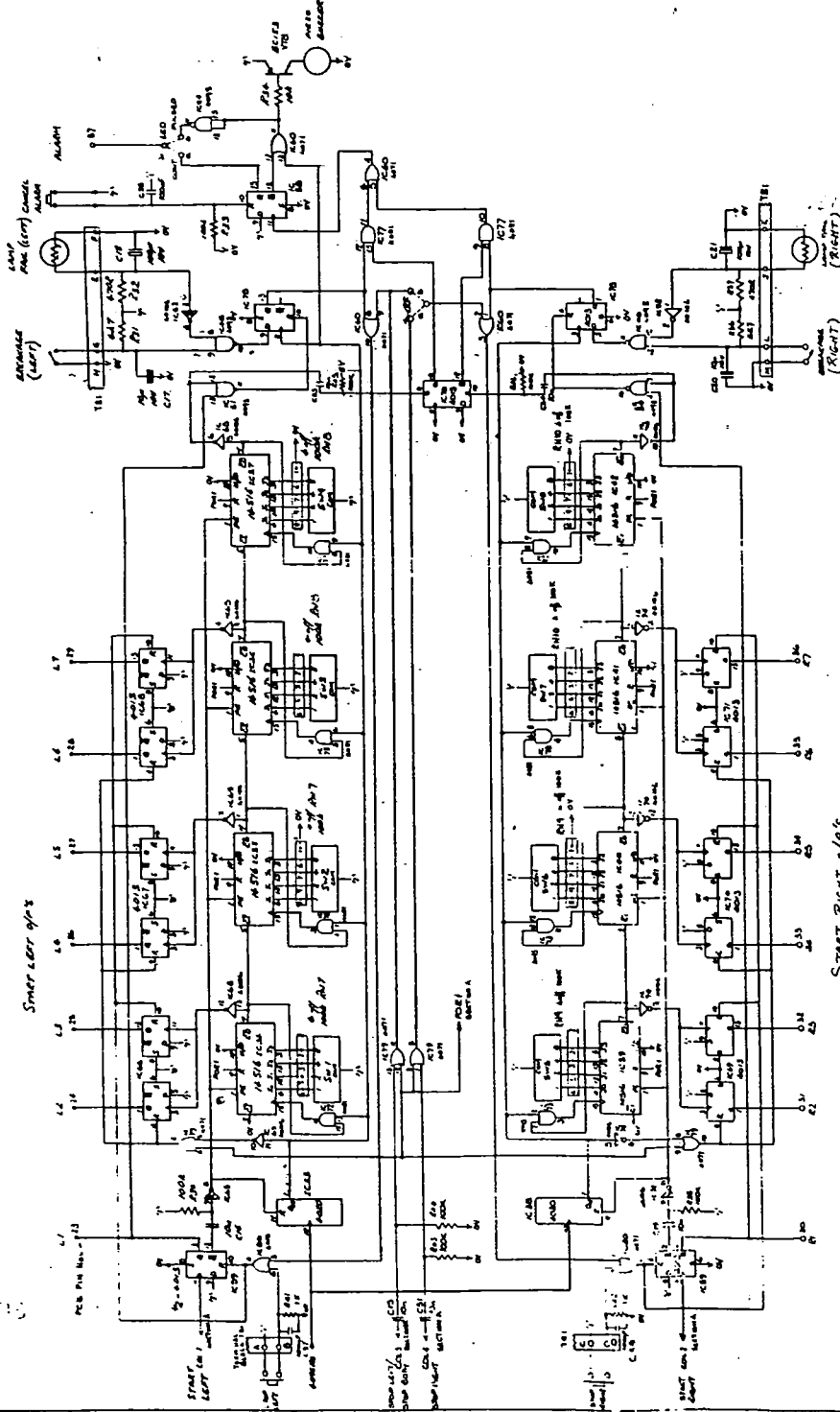
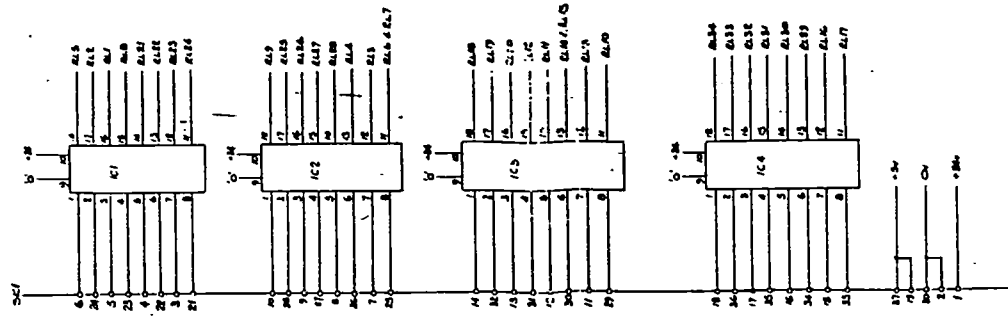

Projector Start Sequence (Left & Right)

- Section B

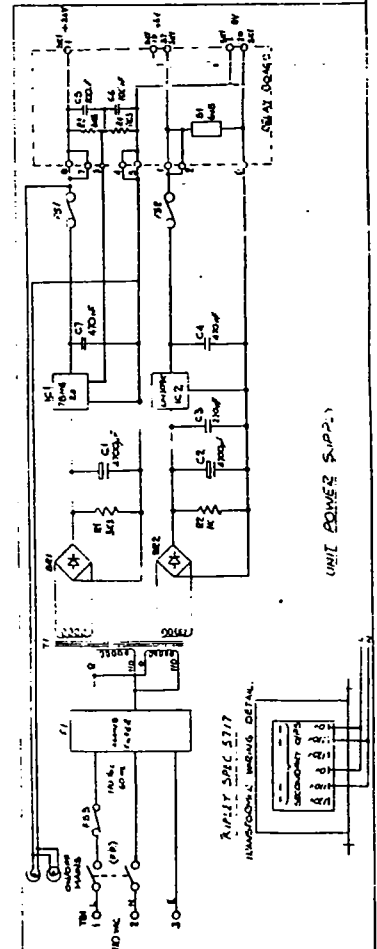

UNIT POWER SUPPLY

1/ LL 8-2-10

DATE	DESCRIPTION
11-1-68	ISSUE C
11-1-68	ISSUE B
11-1-68	ISSUE A
11-1-68	ISSUE 0
11-1-68	ISSUE -1
11-1-68	ISSUE -2
11-1-68	ISSUE -3
11-1-68	ISSUE -4
11-1-68	ISSUE -5
11-1-68	ISSUE -6
11-1-68	ISSUE -7
11-1-68	ISSUE -8
11-1-68	ISSUE -9
11-1-68	ISSUE -10
11-1-68	ISSUE -11
11-1-68	ISSUE -12
11-1-68	ISSUE -13
11-1-68	ISSUE -14
11-1-68	ISSUE -15
11-1-68	ISSUE -16
11-1-68	ISSUE -17
11-1-68	ISSUE -18
11-1-68	ISSUE -19
11-1-68	ISSUE -20
11-1-68	ISSUE -21
11-1-68	ISSUE -22
11-1-68	ISSUE -23
11-1-68	ISSUE -24
11-1-68	ISSUE -25
11-1-68	ISSUE -26
11-1-68	ISSUE -27
11-1-68	ISSUE -28
11-1-68	ISSUE -29
11-1-68	ISSUE -30
11-1-68	ISSUE -31
11-1-68	ISSUE -32
11-1-68	ISSUE -33
11-1-68	ISSUE -34
11-1-68	ISSUE -35
11-1-68	ISSUE -36
11-1-68	ISSUE -37
11-1-68	ISSUE -38
11-1-68	ISSUE -39
11-1-68	ISSUE -40
11-1-68	ISSUE -41
11-1-68	ISSUE -42
11-1-68	ISSUE -43
11-1-68	ISSUE -44
11-1-68	ISSUE -45
11-1-68	ISSUE -46
11-1-68	ISSUE -47
11-1-68	ISSUE -48
11-1-68	ISSUE -49
11-1-68	ISSUE -50
11-1-68	ISSUE -51
11-1-68	ISSUE -52
11-1-68	ISSUE -53
11-1-68	ISSUE -54
11-1-68	ISSUE -55
11-1-68	ISSUE -56
11-1-68	ISSUE -57
11-1-68	ISSUE -58
11-1-68	ISSUE -59
11-1-68	ISSUE -60
11-1-68	ISSUE -61
11-1-68	ISSUE -62
11-1-68	ISSUE -63
11-1-68	ISSUE -64
11-1-68	ISSUE -65
11-1-68	ISSUE -66
11-1-68	ISSUE -67
11-1-68	ISSUE -68
11-1-68	ISSUE -69
11-1-68	ISSUE -70
11-1-68	ISSUE -71
11-1-68	ISSUE -72
11-1-68	ISSUE -73
11-1-68	ISSUE -74
11-1-68	ISSUE -75
11-1-68	ISSUE -76
11-1-68	ISSUE -77
11-1-68	ISSUE -78
11-1-68	ISSUE -79
11-1-68	ISSUE -80
11-1-68	ISSUE -81
11-1-68	ISSUE -82
11-1-68	ISSUE -83
11-1-68	ISSUE -84
11-1-68	ISSUE -85
11-1-68	ISSUE -86
11-1-68	ISSUE -87
11-1-68	ISSUE -88
11-1-68	ISSUE -89
11-1-68	ISSUE -90
11-1-68	ISSUE -91
11-1-68	ISSUE -92
11-1-68	ISSUE -93
11-1-68	ISSUE -94
11-1-68	ISSUE -95
11-1-68	ISSUE -96
11-1-68	ISSUE -97
11-1-68	ISSUE -98
11-1-68	ISSUE -99
11-1-68	ISSUE -100

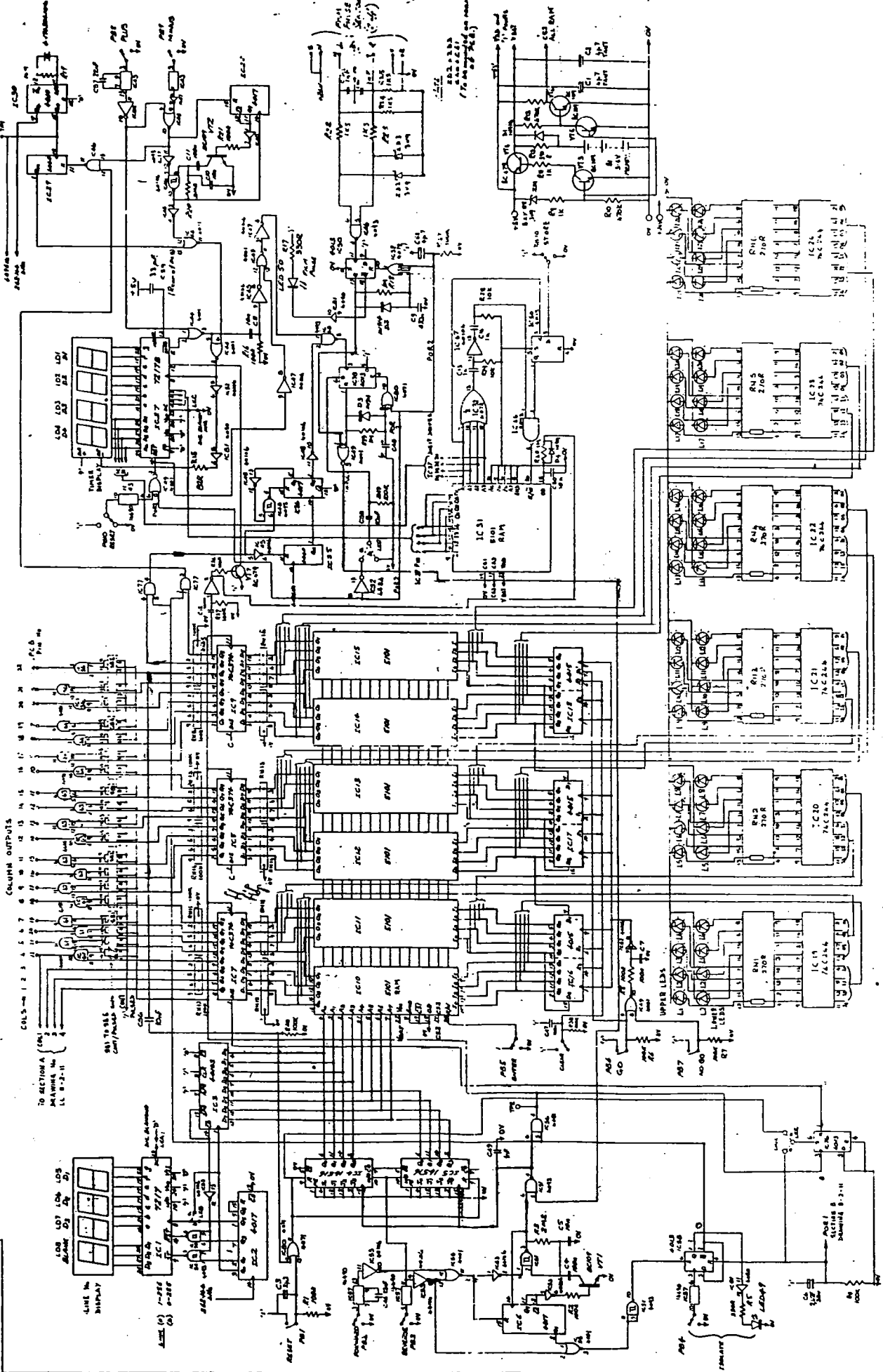

Cinematron Control Unit - Section A LL 8-2-10

SINGLE PHASE POWER

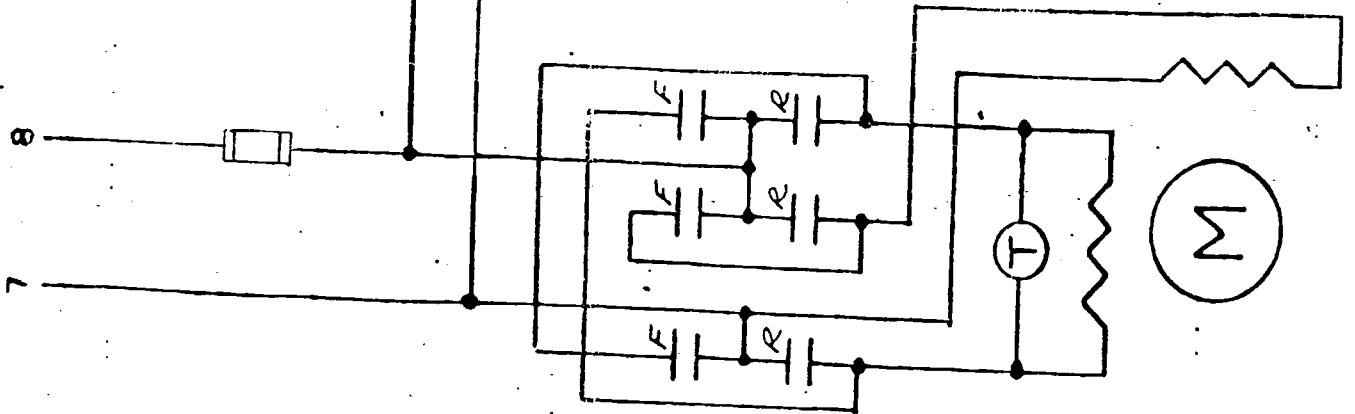

REMOTE
WIRING

LIE #1, #2, #5
TOGETHER FOR
CONTROL OPER.

OPEN - RAISE

CLOSE - LOWER

STOP

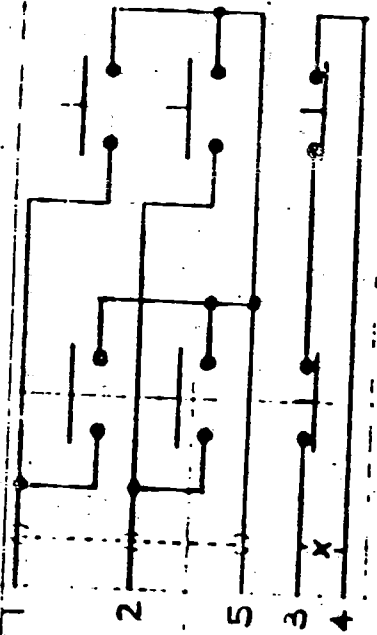

NOT USED ON FULL
VOLTAGE CONTROL

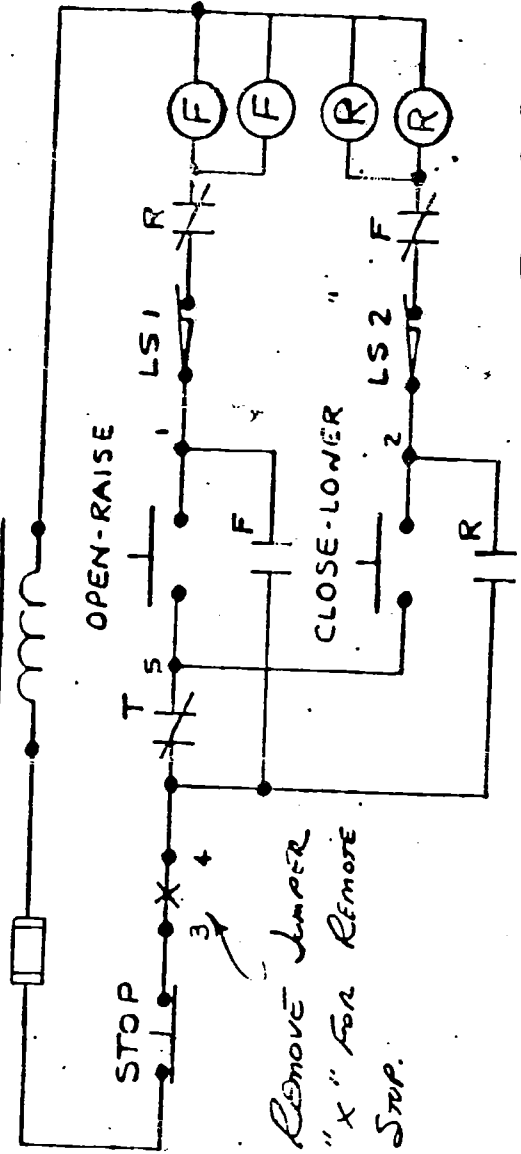

SINGLE PHASE CURTAIN
MACHINE WITH MAGNETIC

SK 080581
AUTOMATIC DEVICES COMPANY
2121 S. 12th STREET

ISSUE	DATE	DESCRIPTION OF CHANGE
ISSUE C		ISSUE C (27.4-33) C33 22mF CHANGED TO 33mF C39 33pF ADDED R23 + R23 300 OHMS ADDED R24 + R25 CHANGED FROM 10K TO 1K5 R26 + R27 CHANGED FROM 10K TO 1K5 C33 CHANGED FROM 22mF TO 33mF
ISSUE D	12-10-85	ISSUE D 12-10-85 C5 CHANGED FROM 350-1 TO 2-1 R9, R11 CHANGED FROM 10K TO 1K PARTIAL RE-DRAW

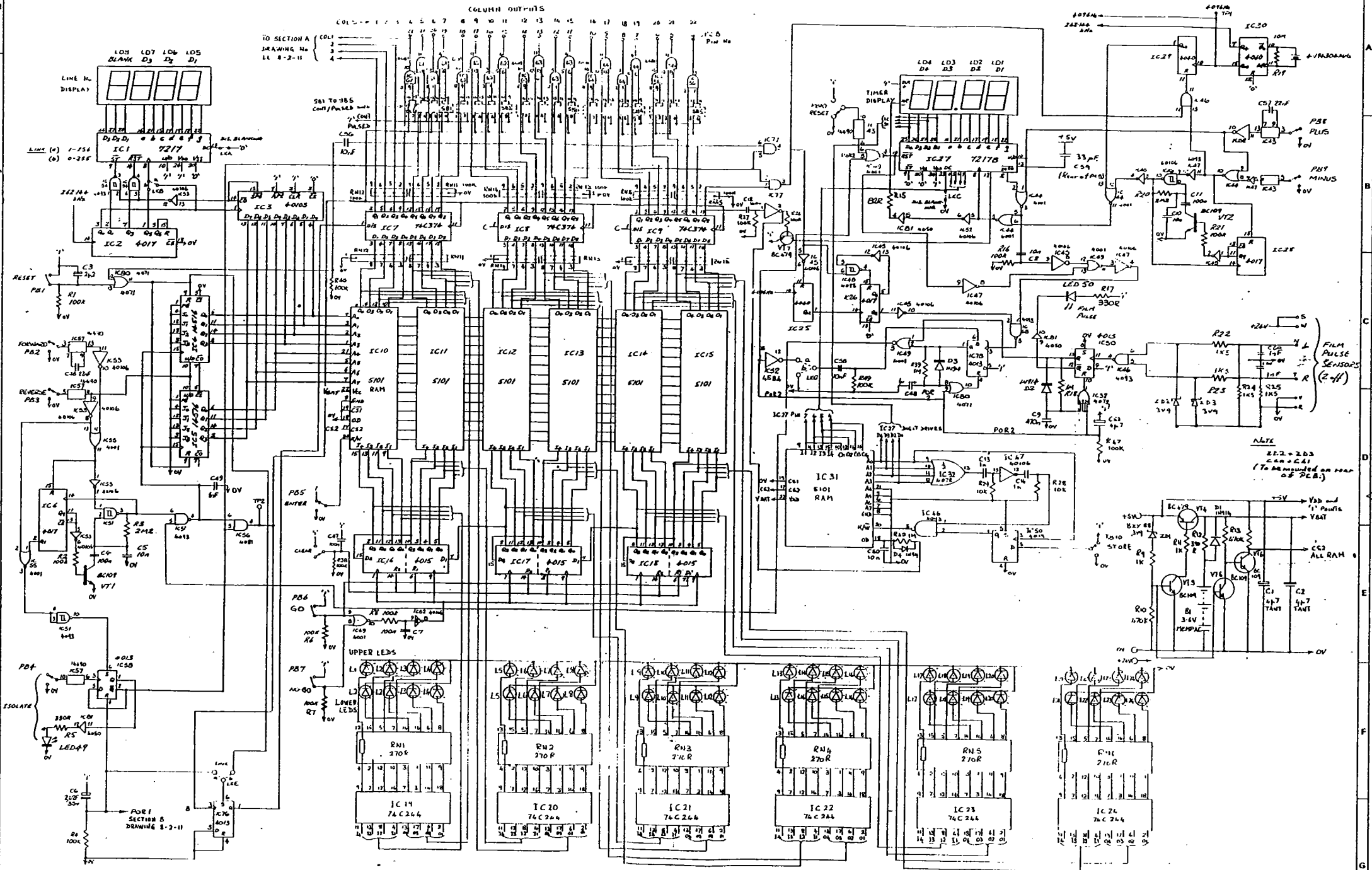

Cinemation Control Unit - Section A LL 8-2-10

A	ISSUE NO.	DATE	DESCRIPTION OF CHANGE
C	ISSUE C (27-L-B3) 27-L-B33 27-L-B34 27-L-B35 27-L-B36 27-L-B37 27-L-B38 27-L-B39 27-L-B40 27-L-B41 27-L-B42 27-L-B43 27-L-B44 27-L-B45 27-L-B46 27-L-B47 27-L-B48 27-L-B49 27-L-B50 27-L-B51 27-L-B52 27-L-B53 27-L-B54 27-L-B55 27-L-B56 27-L-B57 27-L-B58 27-L-B59 27-L-B60 27-L-B61 27-L-B62 27-L-B63 27-L-B64 27-L-B65 27-L-B66 27-L-B67 27-L-B68 27-L-B69 27-L-B70 27-L-B71 27-L-B72 27-L-B73 27-L-B74 27-L-B75 27-L-B76 27-L-B77 27-L-B78 27-L-B79 27-L-B80 27-L-B81 27-L-B82 27-L-B83 27-L-B84 27-L-B85 27-L-B86 27-L-B87 27-L-B88 27-L-B89 27-L-B90 27-L-B91 27-L-B92 27-L-B93 27-L-B94 27-L-B95 27-L-B96 27-L-B97 27-L-B98 27-L-B99 27-L-B100		
B	ISSUE D 27-L-B3 27-L-B4 27-L-B5 27-L-B6 27-L-B7 27-L-B8 27-L-B9 27-L-B10 27-L-B11 27-L-B12 27-L-B13 27-L-B14 27-L-B15 27-L-B16 27-L-B17 27-L-B18 27-L-B19 27-L-B20 27-L-B21 27-L-B22 27-L-B23 27-L-B24 27-L-B25 27-L-B26 27-L-B27 27-L-B28 27-L-B29 27-L-B30 27-L-B31 27-L-B32 27-L-B33 27-L-B34 27-L-B35 27-L-B36 27-L-B37 27-L-B38 27-L-B39 27-L-B40 27-L-B41 27-L-B42 27-L-B43 27-L-B44 27-L-B45 27-L-B46 27-L-B47 27-L-B48 27-L-B49 27-L-B50 27-L-B51 27-L-B52 27-L-B53 27-L-B54 27-L-B55 27-L-B56 27-L-B57 27-L-B58 27-L-B59 27-L-B60 27-L-B61 27-L-B62 27-L-B63 27-L-B64 27-L-B65 27-L-B66 27-L-B67 27-L-B68 27-L-B69 27-L-B70 27-L-B71 27-L-B72 27-L-B73 27-L-B74 27-L-B75 27-L-B76 27-L-B77 27-L-B78 27-L-B79 27-L-B80 27-L-B81 27-L-B82 27-L-B83 27-L-B84 27-L-B85 27-L-B86 27-L-B87 27-L-B88 27-L-B89 27-L-B90 27-L-B91 27-L-B92 27-L-B93 27-L-B94 27-L-B95 27-L-B96 27-L-B97 27-L-B98 27-L-B99 27-L-B100		
D			
E			
F			
G			

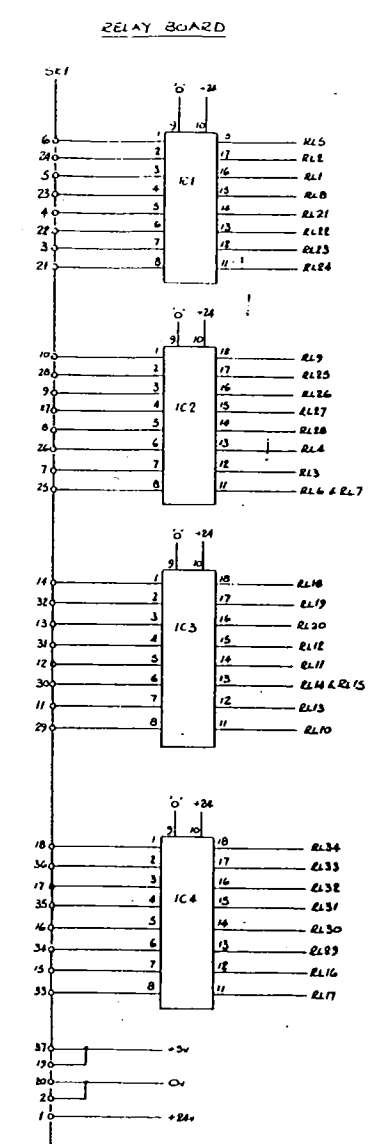
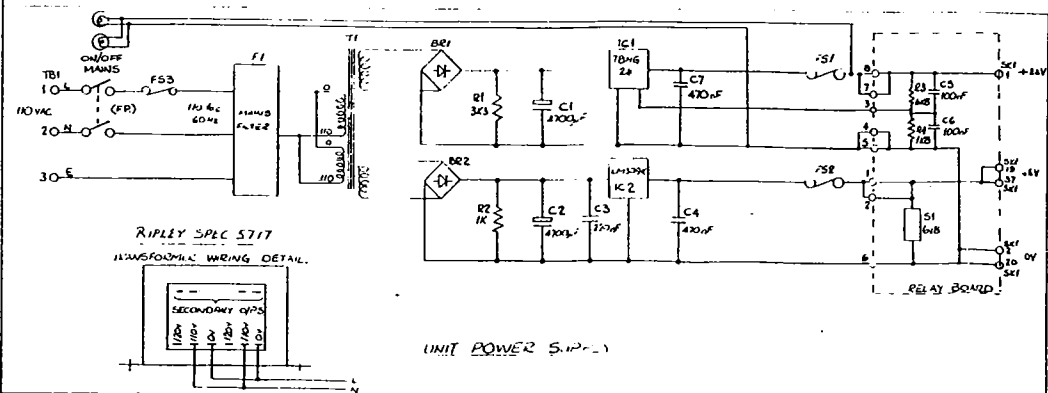
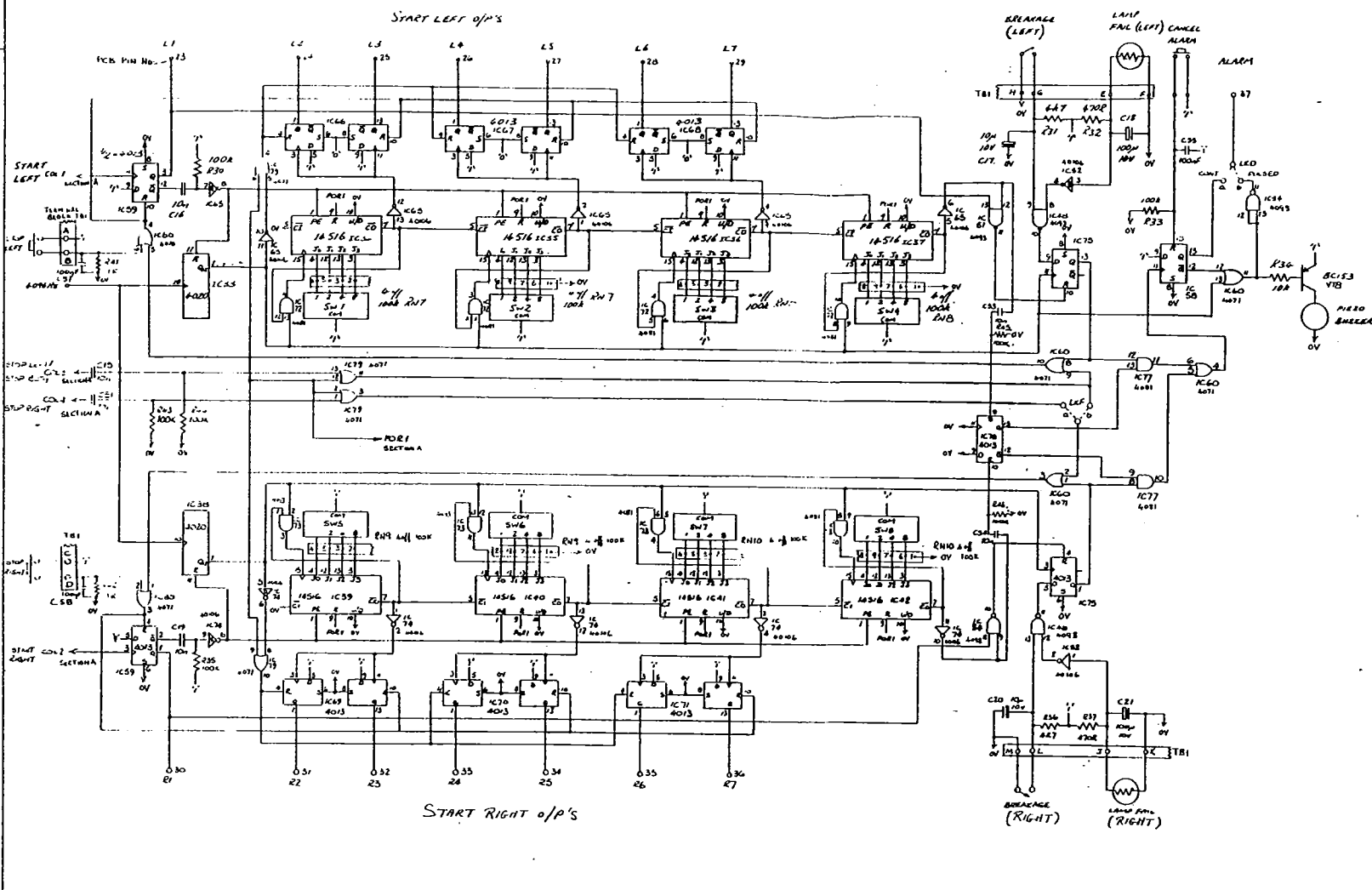

Projector Start Sequence (Left & Right)
- Section B

1 2 3 4
 RL3
 5 6 7 8 9 10 11 12

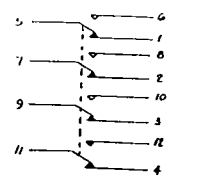
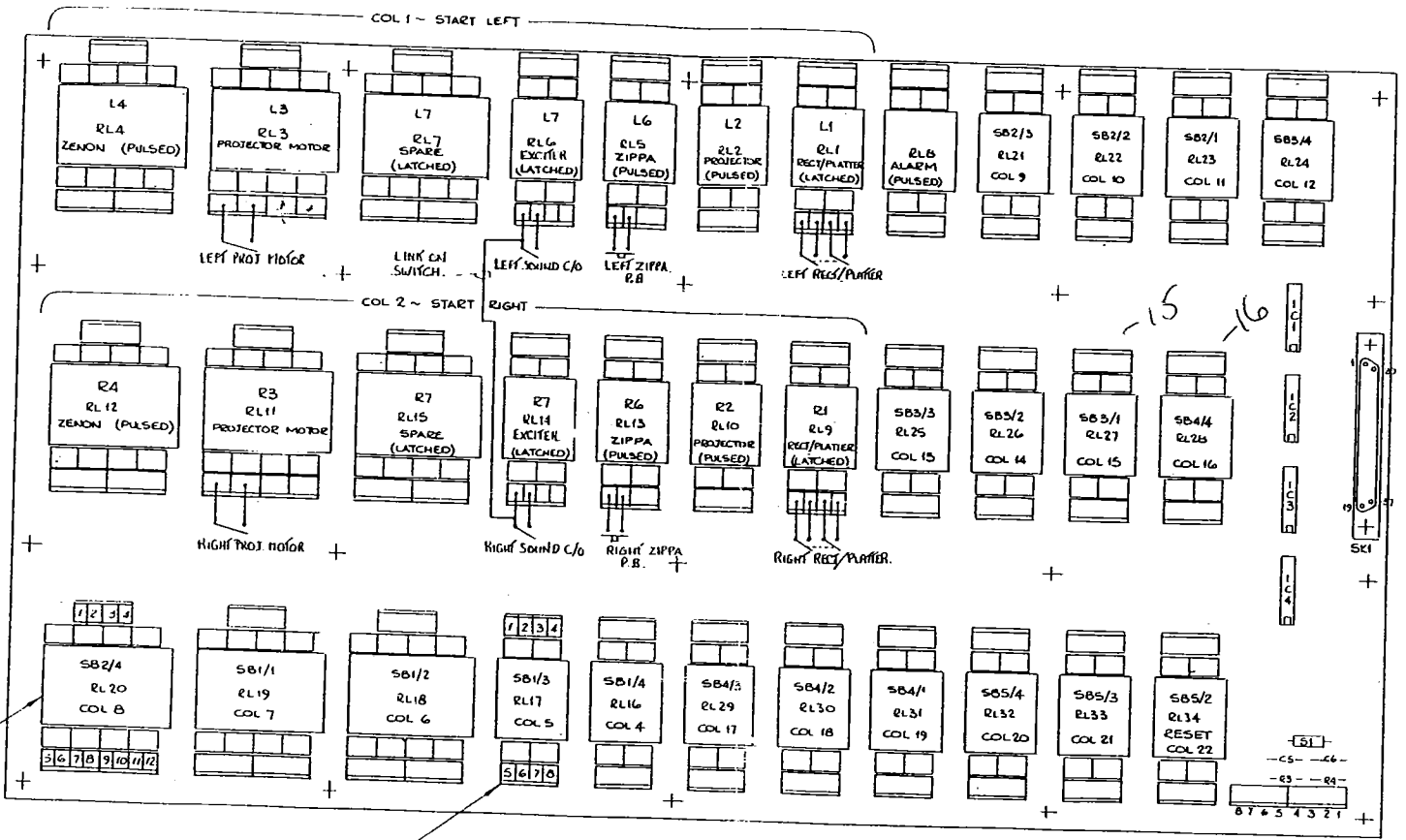

TYPICAL CONNECTIONS TO ALL 9 4-POLE RELAYS

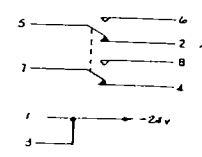

TYPICAL CONNECTIONS TO ALL 25 2-POLE RELAYS

Relay Board Assy FPC-1

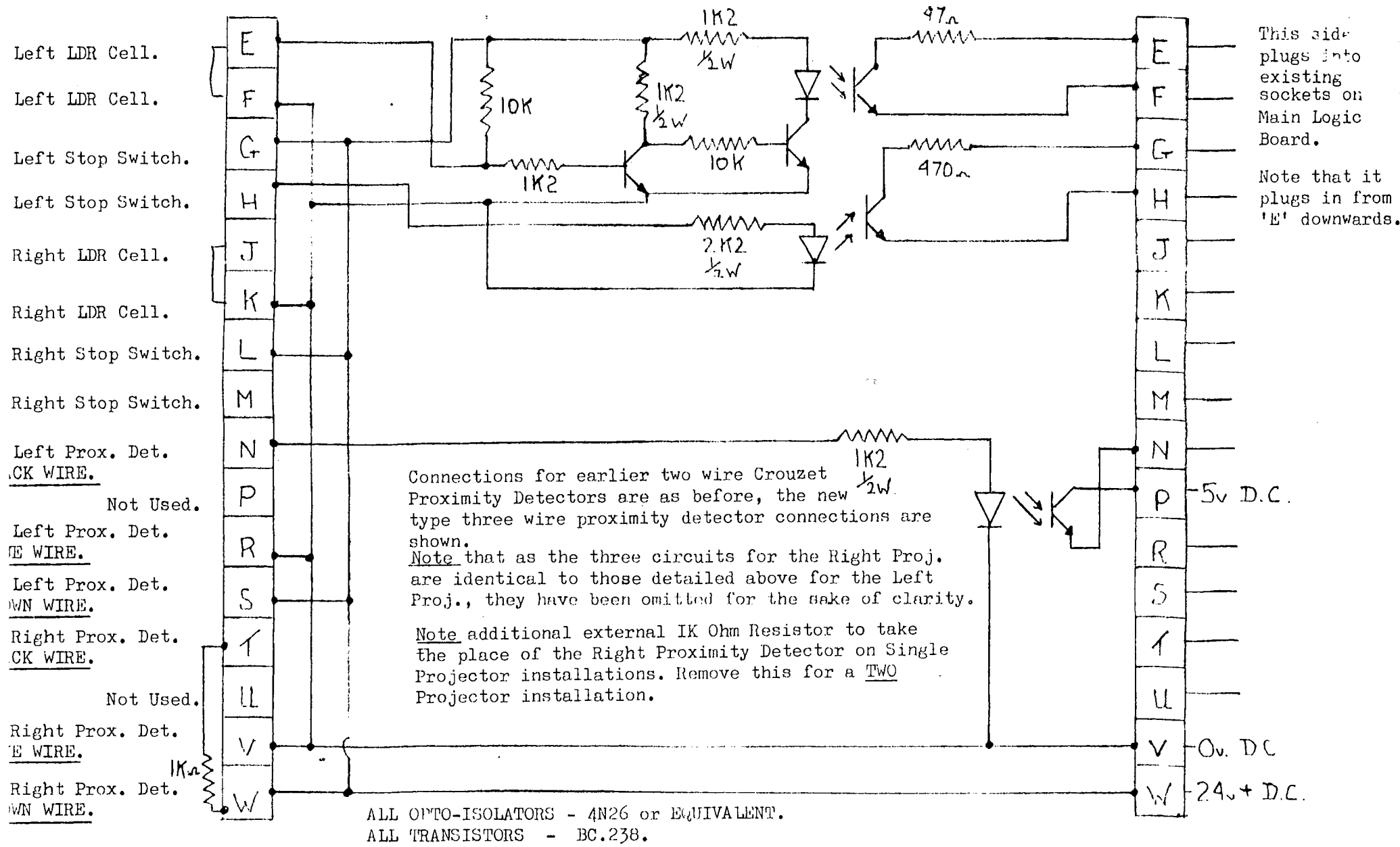

This side plugs into existing sockets on Main Logic Board.
 Note that it plugs in from 'E' downwards.

OPERATION CONTROLS. OPTO-ISOLATION PLUG IN PRINTED CIRCUIT BOARD.

TO BE USED IN CONJUNCTION WITH MICRO-SWITCH OPERATED STOP DEVICES THE BOTH SIDES OF WHICH ARE TO BE ABOVE GROUND. IF STOP ROLLERS ARE USED THE SPINDLE AND BODY OF THE ROLLER SHOULD BE ISOLATED FROM THE MAIN BODY OF THE PROJECTOR SO THAT BOTH STOP WIRES HAVE NO CONNECTION TO GROUND.