

# Film-Tech

The information contained in this Adobe Acrobat pdf file is provided at your own risk and good judgment.

These manuals are designed to facilitate the exchange of information related to cinema projection and film handling, with no warranties nor obligations from the authors, for qualified field service engineers.

If you are not a qualified technician, please make no adjustments to anything you may read about in these Adobe manual downloads.

[www.film-tech.com](http://www.film-tech.com)

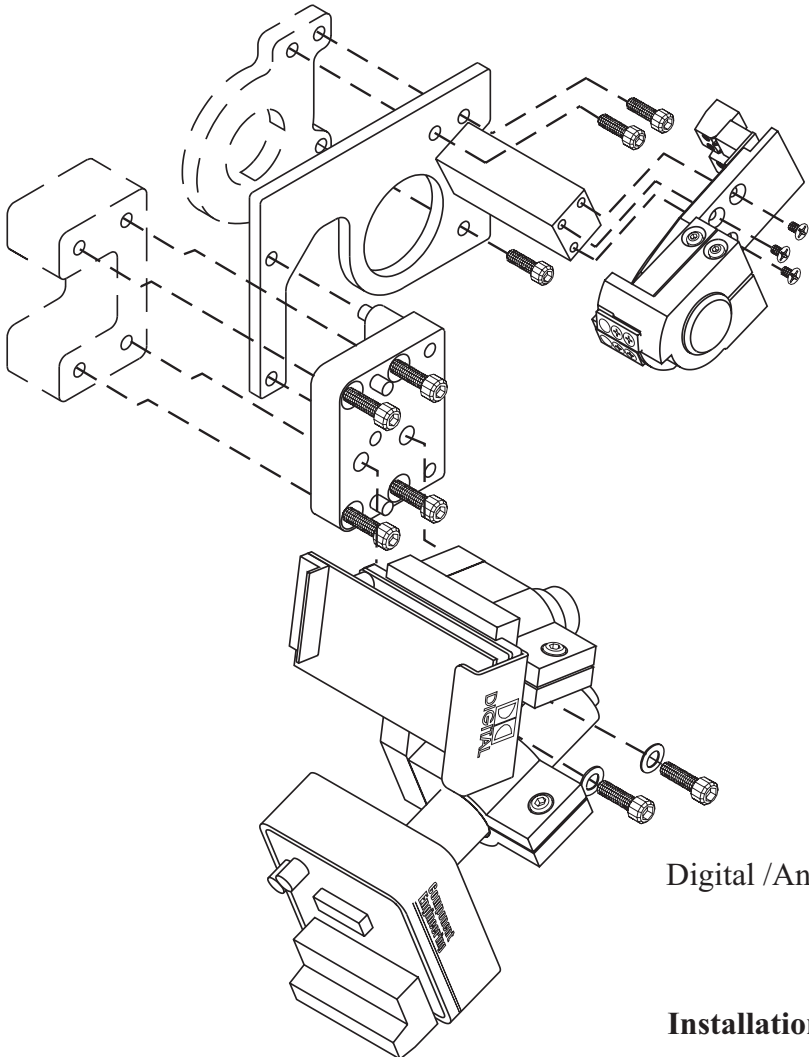

# STRD-30S

Digital /Analog Sound Reader for Simplex Projectors

### Installation Instructions

The following installation instructions assume that all conventional sound track reading elements have been removed from the sound head. These include the exciter lamp and its socket assembly, the slit lens with its mounting bracket, and the entire photocell assembly. The sound drum (rotary stabilizer) and its ball bearings must also be removed temporarily.

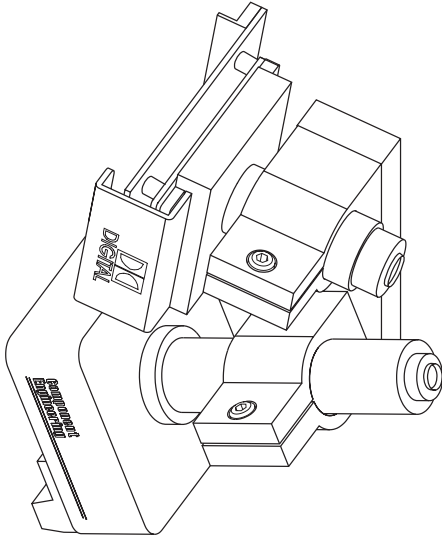

Analog and digital sound pre-amps

**NOTE:** The **analog and digital sound pre-amps** and their optics are shipped already installed in the dual lens mount. This assembly has been pre-aligned in a standard Simplex 5 Star sound head. You are strongly urged to leave it as a unit so that when you are ready to do the final alignment of the sound head, focus and azimuth will be very close to their final positions.

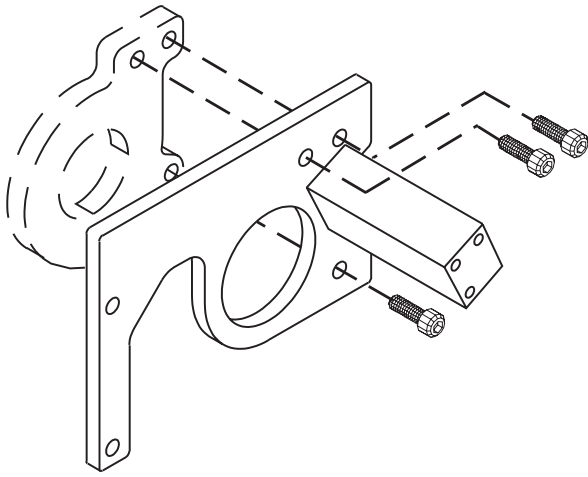

**Position the locator plate**

As you begin the installation please refer to the drawings on the left. The first part to install is the locator plate. This is a 3/16" (4.7mm) thick flat aluminum piece in which there is a large hole....just the size of the drum shaft ball bearings. Attached to the plate is a standoff post used to support the L.E.D. assembly.

**Position the locator plate's** large hole over the sound drum's ball bearing seat and hold in place with three 8-32 X 1/2" screws through the holes on the right side of the plate. **Do not tighten these screws.**

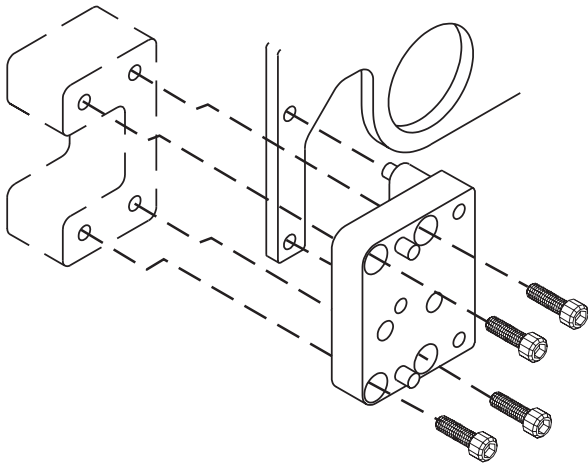

**Install the adapter block**

This is a good time to also loosely **install the adapter block**. Look at the locator plate you just put in, and in the tongue-like piece on the left you will see two holes into which the dowels from the adapter block are to be inserted. They are supposed to be snug, so you may have to proceed slowly. The four mounting holes in the adapter block will now be over the tapped holes originally used to mount the slit lens holder in the casting. Install the four 8-32 X 1/2" screws but do not tighten.

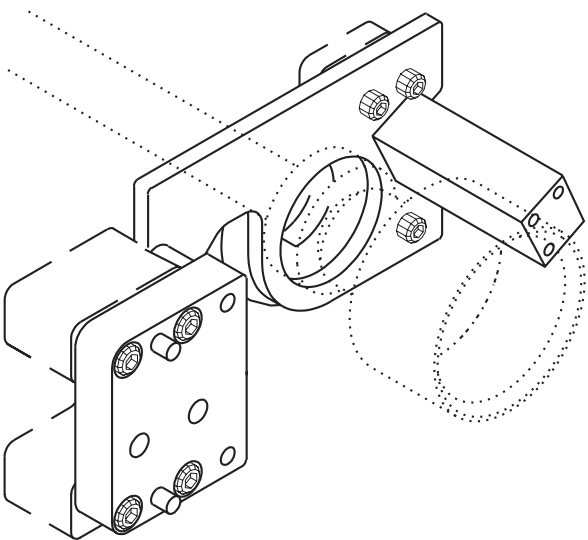

**Optical pieces properly aligned**

The reason for all this loose mounting is so that we can get all of the **optical pieces properly aligned** exactly on radius with reference to the center line of the sound drum. You are going to use the outboard sound drum bearing to accurately position the locator plate, and then all the other parts will automatically be aligned. You can do this either with a loose bearing, or, as is usually the case, with the bearing still on the shaft. The idea is to slide the bearing through the large hole in the locator plate and part way into the bearing seat. With the bearing partly in the plate and partly in the bearing seat, the plate will be positioned exactly on center with respect to the sound drum. Now you can tighten the three screws which hold the plate, the four screws in the adapter block, and finish reinstalling the sound drum and flywheel.

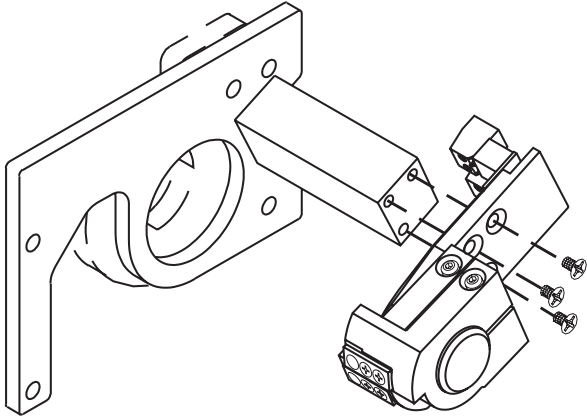

**L.E.D assembly**

The **L.E.D assembly** can now be mounted to the top of the standoff post by means of three 4-40 Flat Head screws. The Lateral Guide can also be reinstated.

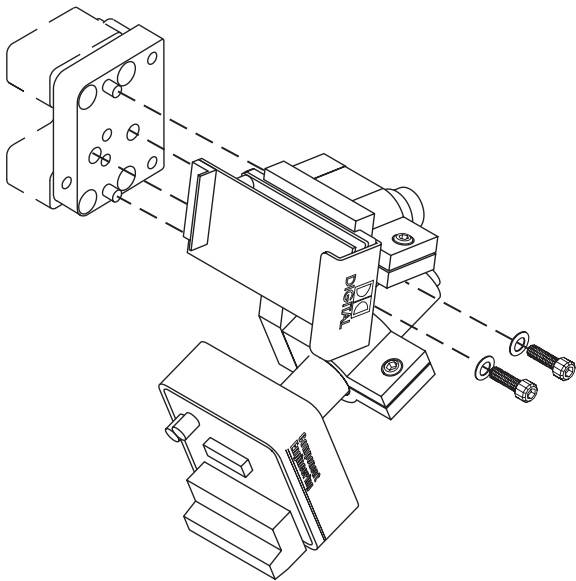

**Dual lens/pre-amp assembly**

The **dual lens/pre-amp assembly** should now be carefully eased onto the dowel pins in the adapter block and bolted in place. It is a good idea to have the digital video cable already plugged onto the digital pre-amp circuit board before you mount this assembly.

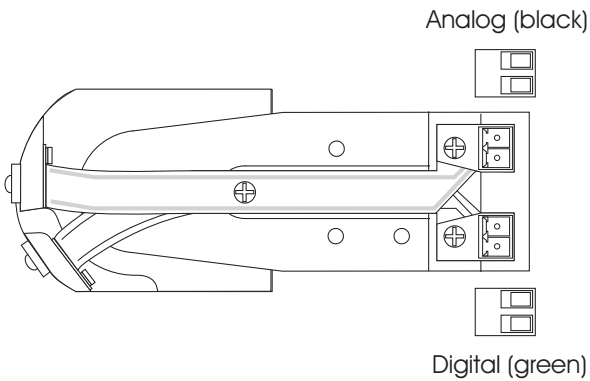

**Rear of the L.E.D . assembly**

### **Wiring**

Connect both of the L.E.D.'s to the outputs of the LS-30 power supply chassis. The small terminal strips at the **rear of the L.E.D. assembly** can be unplugged by pushing away from you. Note that no polarity is indicated. This is because the L.E.D.'s may come with either polarity and you will have to determine the correct connection by trial and error. It is safe to do this because the output of the LS-30 power supplies is clamped at a voltage too low to damage the L.E.D.'s. The recommended wire size is #18 AWG.

## Backplane of LS-30 Power Supply

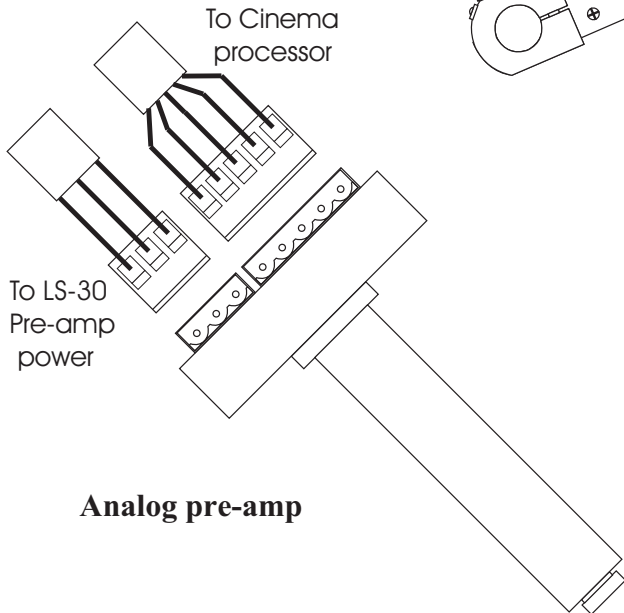
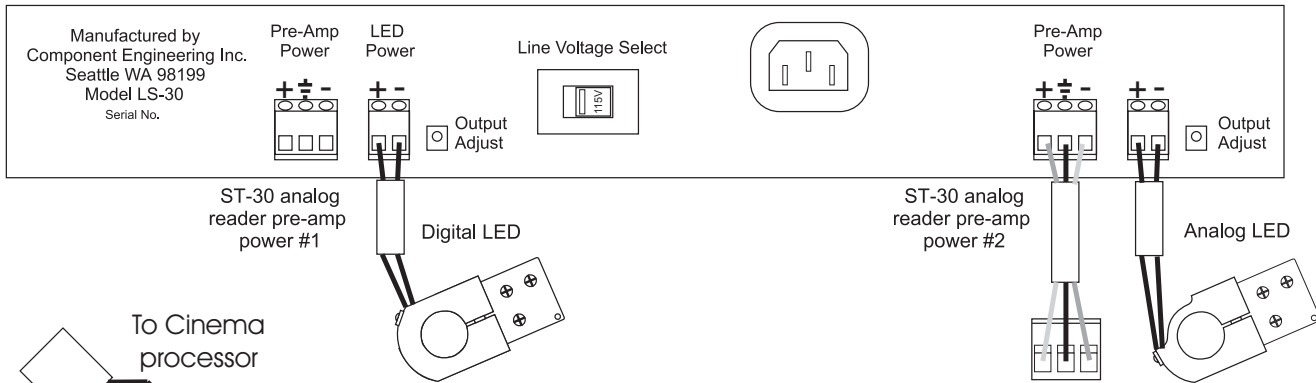

The **analog pre-amp** is powered by the 12 Volt bipolar supply in the LS-30 and three conductor 22 Gauge wire is perfectly adequate for this purpose.

The analog audio output from the pre-amp should be two shielded pairs, one for each channel. They can be individual cables, or two pairs in one jacket. Normal audio wire such as you would use for any other purpose is ideal.

All of the terminal strips on the analog pre-amp can be unplugged at the pre amp.

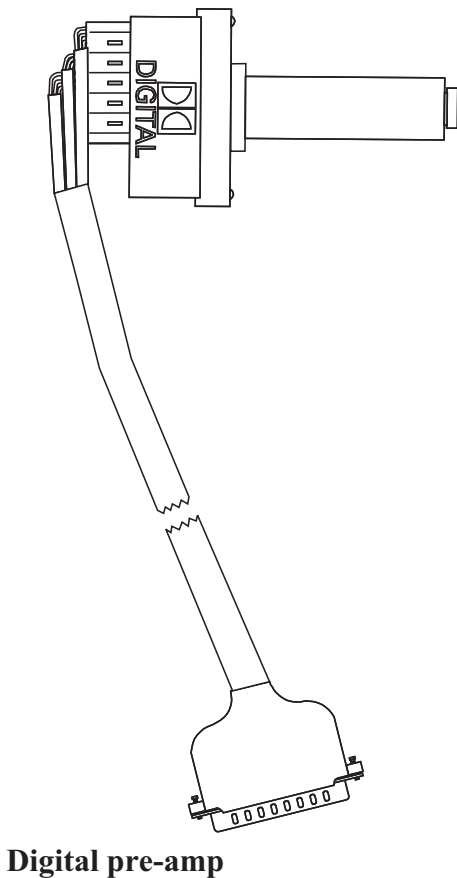

The video output cable from the **digital pre-amp** in the sound head to the Dolby DA-10 or DA-20 is harder to deal with because it is so stiff and heavy. The cables are shipped with both ends terminated in their respective connectors. The smaller connector (the sound head end) can be gotten through 3/4" conduit, but care must be taken if there are many bends and particularly when going through any conduit fittings. The connector is polarized and will plug onto the video pre-amp only one way.

## Alignment

### Preliminary:

Because you are dealing with two soundtracks, and because you are starting from scratch, you will have to go back and forth between the two media while you get everything optimized. Mostly, this means the **adjustment of the two light sources**. The good news is that as already mentioned, the two optical assemblies have been preset so that you have a beginning point. Their focus and azimuth may not be exactly correct for your sound head, but they will be close enough to get you started. Loosen the clamp screw of both of the copper L.E.D. mounts until they can be moved easily, but will stay where you put them when you let go. It is easier to grab both of the mounts when doing the analog L.E.D. (which is the inner one), and so it is best to do it first.

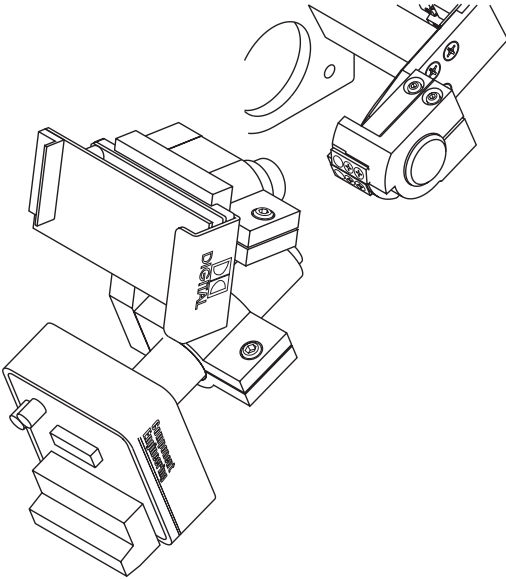

### Adjustment of the two light sources

### Analog:

**Adjust the analog L.E.D.** by eye until it looks as though it is opposite the lower lens. In the cinema processor, turn both the level and high frequency adjustments all the way down so that both channels will be essentially identical. Thread a loop of Dolby Cat. No. 97 (a very convenient method is to make a loop of 1/2 Cat. No. 97, and 1/2 “Buzz Track”) and look at it on your oscilloscope just as you would for a normal “A” Chain setup.

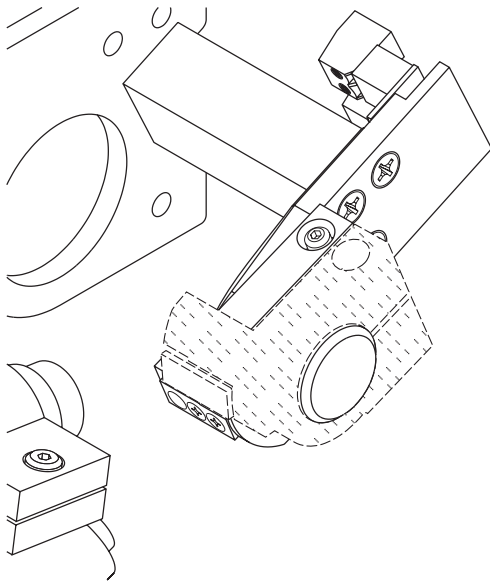

### Adjust the analog L.E.D.

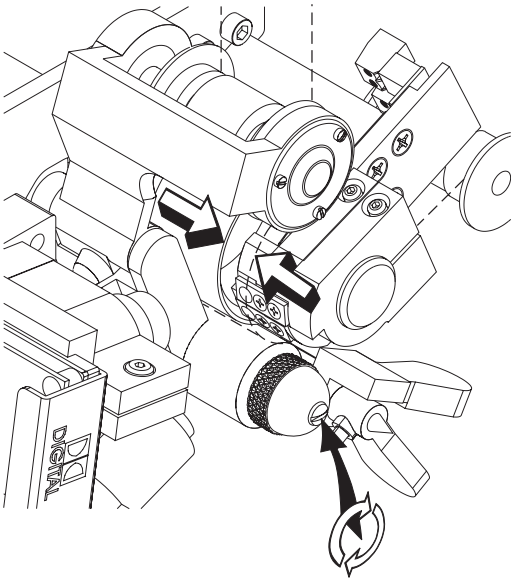

**Adjust the lateral guide roller** until you have agreement between both the Cat. No. 97 and the “Buzz Track”. Adjust the lateral position of the L.E.D. for maximum output from both channels. The lateral guide position is important because it also establishes the correct position for reading the digital track.

### Adjust the lateral guide roller

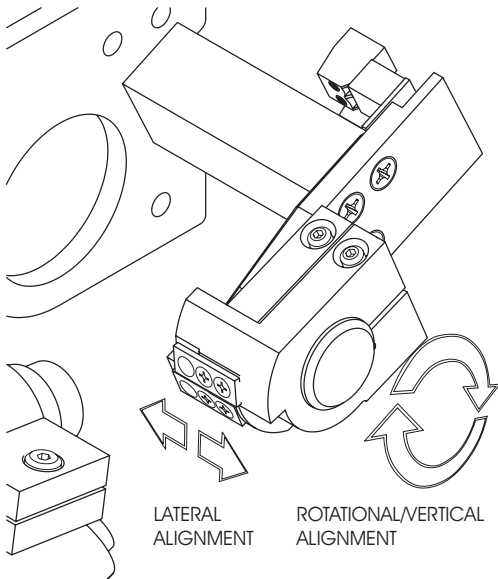

Move the L.E.D. in and out and vertically (rotationally) until you have achieved the maximum output from both channels. Gently tighten the clamp screw of the analog mount. Try not to overdo the screw tightening so that the threads in the soft copper are not deformed. There is a large area of contact between the copper plate and the round stud on the support plate which means that it takes only modest clamping pressure to firmly hold the adjustment. (The other reason for this large contact area is that there is very good heat transfer from the L.E.D. itself right on down to the base casting of the sound head. This means extra long life for the L.E.D.)

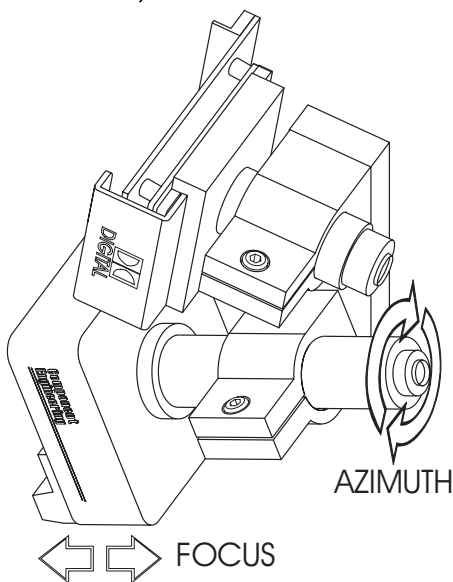

Now is the time to do the rest of the **analog focus and azimuth alignment** procedures. Before you do your final Dolby Tone level adjustment, it is a good idea to run Dolby Cat. No.566 scanning beam illumination film. Touch up the in-and-out adjustment of the L.E.D. if necessary. If you are sure that your vertical, or rotational, adjustment is nearly correct, there is an interesting method of optimizing it. Remove all film from the projector and turn on the motor. Monitor the sound from the reader and turn the gain up until you hear the slight microphonics from the running projector. Tweak ever so carefully the vertical position of the L.E.D. until the least sound is heard. This will be the optimum position of the L.E.D. Lock the clamp screw, set your Dolby Tone level and move on to the digital.

### Analog focus and azimuth alignment

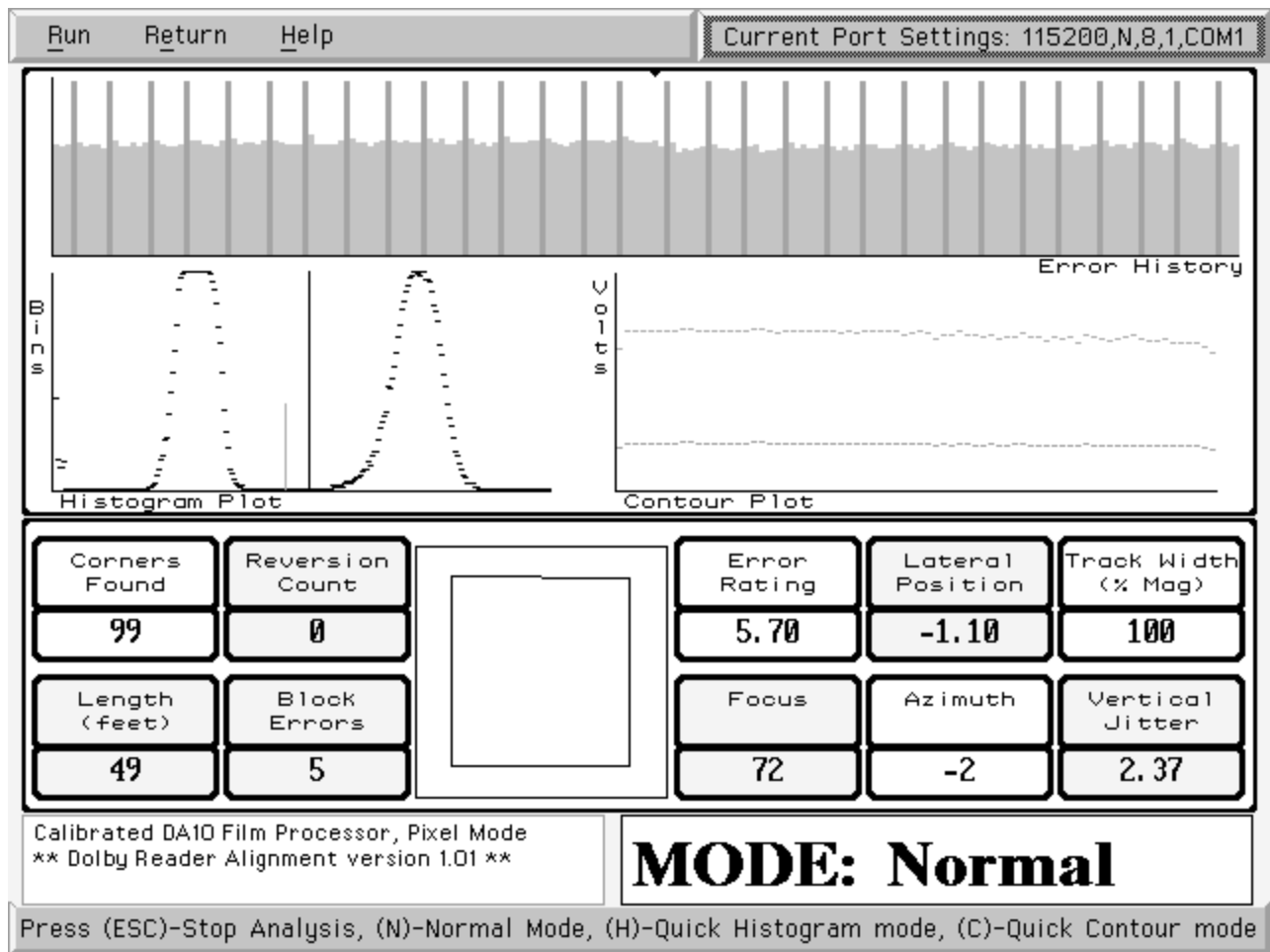

Screen snapshot of DRAS 10 software reading a loop of Dolby Digital test film (note the recurring splice in the Error History)

### Digital:

Connect your 'scope to Dolby's digital processor (DA-10, DA-20, or CP500) according to their instructions, and start running some digital film. The following are optional but highly recommended: A 486 class or better computer having a high-speed (115kbs.) serial port and DRAS-10 software from Dolby. A nine conductor male to female cable with standard 9 pin "D" connectors that are wired pin to pin. It is possible to perform a good alignment using test film and an oscilloscope, or it is possible to use test film and a computer running Dolby's DRAS-10 software.



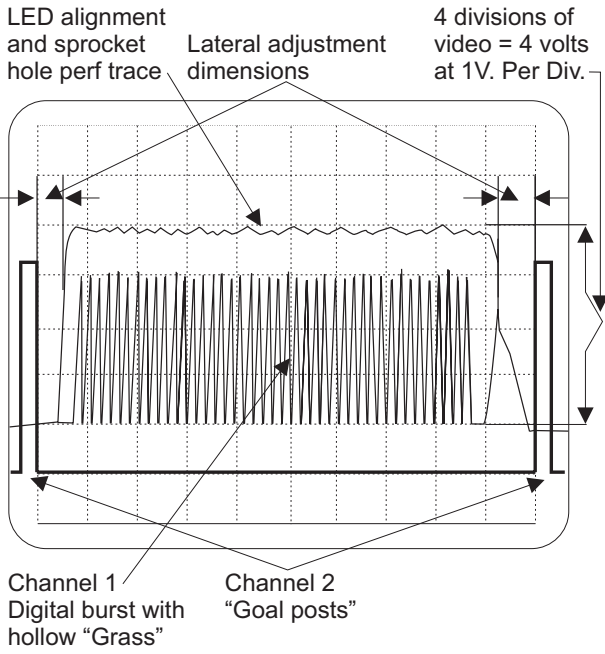

Best of all, however, is to use both at the same time. The 'scope will show you the real-time video of what the reader is "seeing" on the soundtrack, while the computer will numerically display, focus, azimuth, vertical jitter, lateral alignment and more. Taken all together, proper alignment is quick, easy, and accurate. (If you are running loops, try to make them fairly long so that the splice doesn't come around too often). The digital reader optics should be close enough for you to find a 'scope picture similar to this illustration.

The first thing is to **adjust the digital L.E.D.**. You want the brightest and most even light you can get. This will be indicated on the 'scope screen by the flattest trace with the greatest amplitude. Now that you have adjusted the analog L.E.D., you know the routine except that this time you will be working with the outer L.E.D. only. Be careful not to loosen the analog L.E.D. mount so that you won't have to do all that work over again. A large saw tooth surface in the trace means you must fine adjust the rotational alignment of the L.E.D..

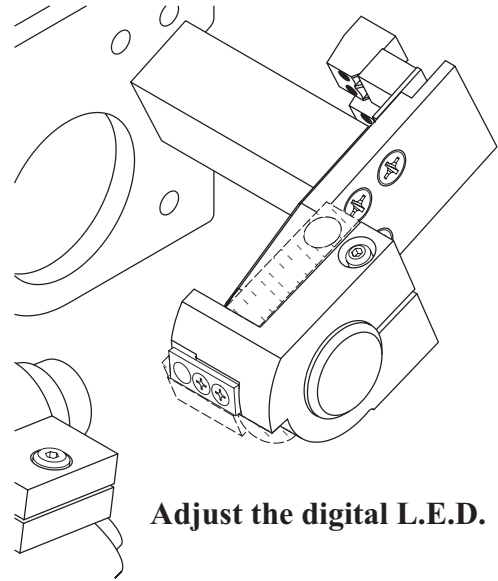

**Adjust the digital L.E.D.**

Lateral misalignment of LED is indicated by trace roll-off.

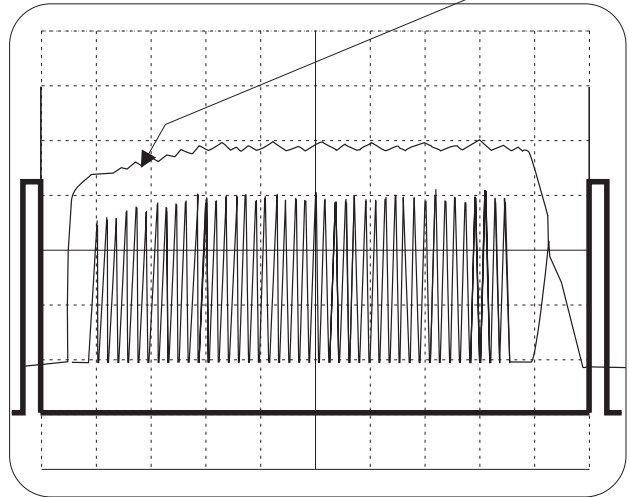

Correct trace height, with incorrect large saw, teeth in initial adjustment.

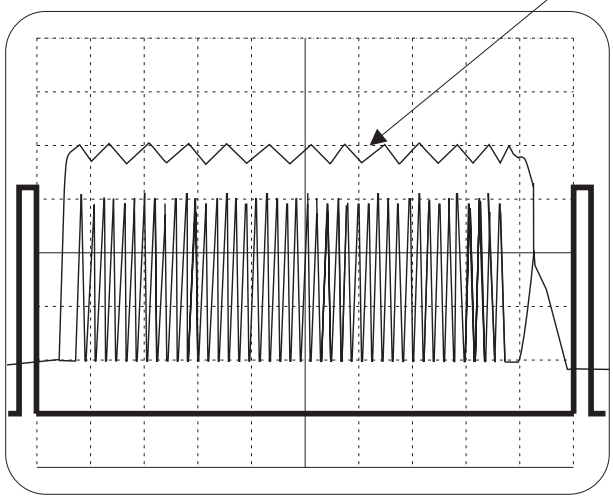

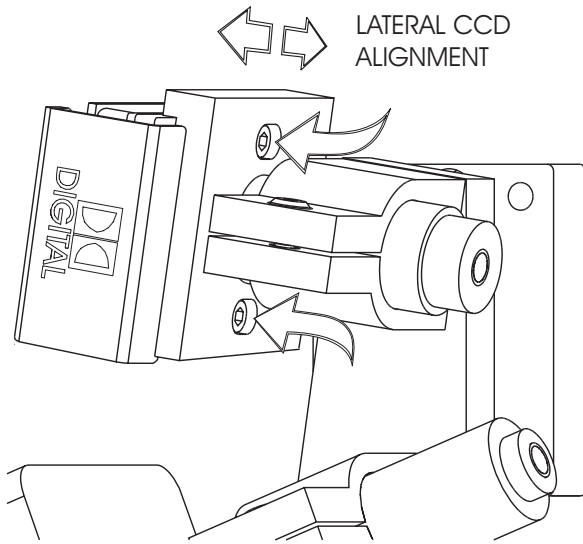

### CCD board lateral adjustment

Correct lateral alignment, dimension X1 is 1/5 graticule smaller than X2

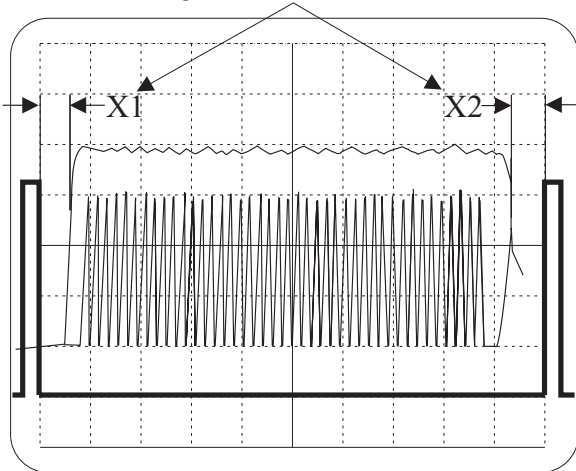

Loosen the **CCD board lateral adjustment** locking screws and adjust the lateral position so that outer trace (perf) is off center by 1/5 major graticule to the left between goal posts. A correct DRAS “lateral position” read out should be as close to zero as possible. As you retighten the screws be careful not to walk the board in the reader.

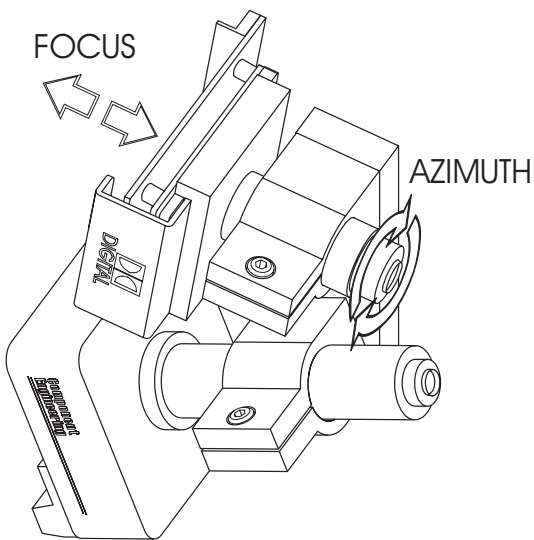

### Adjust focus and azimuth of digital optics.

We are ready to **adjust the focus and azimuth of the digital optics**. Because the optics have been preset there is always the chance that focus may be OK. Adjusting focus and azimuth are similar for digital and analog. The reader clamp is loosened and the reader is moved forward or back to adjust focus. When using the ‘scope a correct digital burst, the “Grass”, will be in good focus and the center area will be somewhat darker, exhibiting “hollowness”. Using DRAS you are looking for the highest “focus” number. Expect to achieve high 60,s to 70,s with our reader.

Rotation of trace indicates incorrect reader azimuth adjustment.

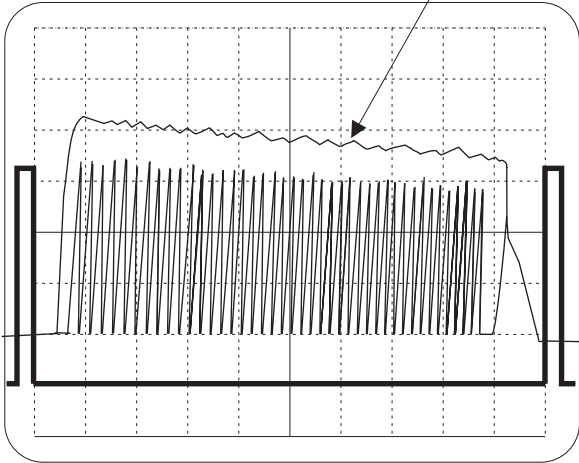

Smooth trace teeth indicates minimum variation of L.E.D. output.

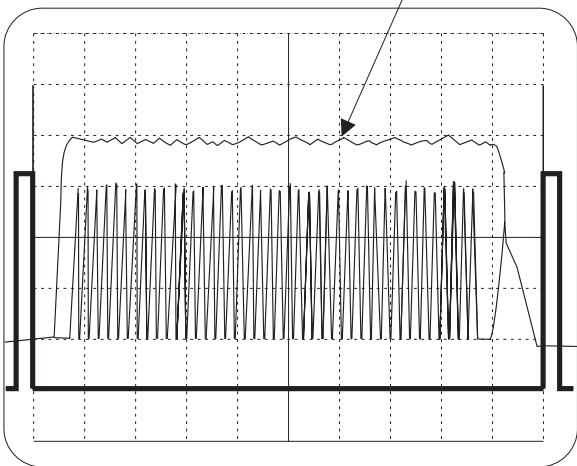

Azimuth adjustment is difficult when using only a 'scope. Rotate the reader to adjust for the flattest sprocket hole "perf" trace and the lowest error rate on the processor display. Large azimuth errors are seen as a tipping of the 'scope sprocket hole "perf" trace. The rotation axis will be the center of the displayed perf trace. The DRAS azimuth number you are looking for is as close to zero as possible. Retighten the clamp screw when both focus and azimuth have been optimized.

#### Final:

As a final check run Dolby Cat. 69T and observe both digital and analog levels and the digital error rate.

#### Analog:

You can go back and double-check the analog setup. Start as you did before by checking lateral position. It should not have changed, but if it has, it is OK to refine it. If you did refine it make sure the Dolby Tone, equalization, scanning beam illumination and lateral guide are still correct.

#### Digital:

The last step is to fine adjust the rotation of the digital LED to minimize the unevenness of the sprocket hole trace. Now run a piece of film with a good sound track and go sit in the theater and "test" some really fine sound.

