

# Film-Tech

The information contained in this Adobe Acrobat pdf file is provided at your own risk and good judgment.

These manuals are designed to facilitate the exchange of information related to cinema projection and film handling, with no warranties nor obligations from the authors, for qualified field service engineers.

If you are not a qualified technician, please make no adjustments to anything you may read about in these Adobe manual downloads.

[www.film-tech.com](http://www.film-tech.com)



**35mm OPTICAL SOUND REPRODUCERS**  
Types R3-E, MR3-E, & JR3-E  
Instructions & Parts Lists

Rev. 3/99

**STRONG  
INTERNATIONAL**

a division of Ballantyne of Omaha, Inc.  
4350 McKinley Street  
Omaha, Nebraska 68112 USA  
Tel 402/453-4444 • Fax 402/453-7238

## TABLE OF CONTENTS

	<u>Page No.</u>
Operator Instructions	i-xi
Replacement Parts, Reverse Scan Components*	xii
 <b><u>PARTS LISTS</u></b>	
	<b><u>Assembly No.</u></b>
Mainframe Overview	1
Mainframe, Pinned Casting Assembly	R22-20E 2
Terminal Panel Assembly	R4-70D 2
Anasol Pick-Up & Bracket Assembly (Direct Scan)	81-98062 2
Damper Assembly	R5-30B 4
Oil Cover & Plunger Assembly	R5-35 4
Lower Damper Arm Assembly	R5-33 5
Lower Damper Arm, Stud & Retaining Ring Assembly	R5-31 5
Lower Damper Roller & Ball Bearing Assembly	R5-36 5
Lower Damper Arm & Ball Bearing Assembly	R5-38 5
Upper Damper Arm Assembly	R5-50 6
Upper Damper Roller & Ball Bearing Assembly	R5-37 6
Upper Damper Arm & Associated Parts	R5-51 6
Upper Damper Arm, Stud, & Retaining Stud Ring	R5-52 6
Exciter Lamp Assembly (Direct Scan)	R3-40 8
Exciter Lamp Socket & Bracket Assembly (Direct Scan)	R3-41 8
Ground Lead Wire & Lug Assembly (Direct Scan)	R3-43 8
Impedance Drum & Flywheel Assembly	R3-50A 9
Pad Roller Arm Assembly	R3-60 11
Pad Roller; Stud, Knob, & Flange Assembly	R2-31 11
Film Compartment Door Assembly	R3-110A 12
Exciter Compartment Door Assembly	R3-120 12
Drive Side Cover Assembly	R3-130 14
Terminal Panel Cover Assembly	R3-300 14
Adjusting Arm Assembly	R50-90B 14
Horizontal Drive Shaft Assembly	R50-70A 16
Horizontal Shaft & Ball Bearings Assembly	R50-72 16
Vertical Drive Shaft Assembly, Flexible	R50-370A 16
Vertical Shaft Bracket & Ball Bearing Assembly	R50-371 16
Drive Motor Mounting Bracket Assembly	17
Lower Take-Up Roller Assembly	R5-80 17
Soundhead Bypass Kit, 70mm Film	R50-500 19
Transfer Roller Assembly, 70mm	R50-505 19
Stabilizer Roller Assembly, 70mm	R50-510 19
Projector Exit Roller Assembly, 70mm	R50-515 20
Failsafe Guide Roller Assembly, 70mm	R50-520 20
Standard (R3) Drive Assembly	21
Kelmar Reverse-Scan Readers	(optional) 23
Drive Motor Kit Options; Pulleys & Belts	27
Drive Motors	28

\* See Page 23 for *optional* Kelmar Reverse-Scan Kit

## OPTICAL SOUNDHEAD Type R3, MR3, JR3

THE CENTURY OPTICAL SOUNDHEAD is designed for optimal reproduction of all optical sound formats. All film-handling elements are mounted to a rugged one-piece main frame casting for maximum stability. The soundhead is factory tested and inspected before shipping, and requires no preliminary "run-in" period at the installation site.

BEFORE USING the optical soundhead, make certain that the CU-0085 Damping Cup (as illustrated below) has been correctly filled with the FD-0120 Damping Fluid supplied with the unit. Loosen the SC-0526 set screw to release the CU-0085 cup from its holder and fill to the scribed ring inside the cup with the FD-0120 fluid provided. Replace the cup and tighten the set screw.

ALL NECESSARY ADJUSTMENTS to the Century Soundhead are made at the factory in the course of testing and run-in. It is recommended, however, to repeat all optical soundtrack scanning adjustments as a preliminary step in the installation of the sound processing equipment. These adjustments are **extremely crucial** for proper sound reproduction, and vibration and handling in shipping can jar components out of alignment. Qualified sound installation personnel are trained and equipped to perform these procedures.

### ELECTRICAL SUPPLY REQUIREMENTS:

**Drive Motor (Domestic):** 115 V.AC, 60 Hz. 15 Amperes

**Drive Motor (Export):** 230 V.AC, 50 Hz. 10 Amperes

See Page 23 for *Optional* Motor Configurations.

**Exciter Lamp (Direct Scan):** 9 Volts, 4 Amperes \*

**L.E.D. Power Supply (Reverse Scan):** 115/230 V.AC, 50/60 Hz. 3 Amperes

\* The Exciter Lamp must be connected to a listed Exciter Lamp Power Supply installed and wired in conformance to local codes.

### THREADING

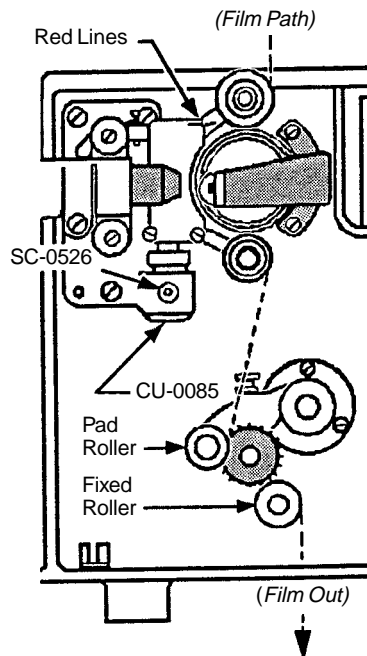

Bring the film from the lower holdback sprocket of the projector mechanism into the soundhead. Open the soundhead pad roller. Thread the film as shown (dashed line) around the impedance drum, under the sprocket, and over the fixed roller. Draw the film taut around the sprocket, and back it off until the (2) red lines (see illustration) are roughly parallel. This indicates correct film tension across the impedance drum. Close the pad roller.

For best performance, periodically clean the interior of the soundhead. Do not allow dust and film residue to accumulate. Any obstruction of the light path of the L.E.D. (Reverse Scan) or the beam of the exciter lamp (Direct Scan) will result in signal loss. Exercise extreme care when working around the solar cell assembly of the Direct-Scanning soundhead. The mirrors on the head of the solar cell are very fragile and are easily damaged. DO NOT reposition the soundtrack scanning components (L.E.D. head, slit lens, etc.).

When ordering replacement parts for the Century Soundhead, please reference both the MODEL and SERIAL number on the Data Plate of the unit.

## ADJUSTMENTS

PAD ROLLERS, when closed, must allow a clearance distance of (2) thicknesses of film between the rollers and the face of the sprocket. This is accomplished by setting the pad roller arm stop screw (Item 7, Page 10) to stop the pad roller closure at the desired (2) film thickness distance between the pad roller (Item 3, Page 10) from the face of the sprocket. Tighten lock nut (Item 6, Page 10) to fix this setting.

MAINTAIN correct belt tension. Tension should be sufficient to allow the belt cogs to firmly engage the pulley teeth, but *do not overtighten*. Excessive belt tension can damage shafts and pulleys and cause premature bearing failure.

ADJUSTMENTS to those components relevant to scanning the optical soundtrack are best performed by qualified personnel equipped with the necessary test equipment. Attempts to effect field repairs without use of the required test equipment are generally detrimental to sound quality.

### DIRECT-SCANNING SOUNDHEADS:

1. The **Exciter Lamp** is preset to position the filament of the lamp for maximum light output to the Slit Lens. The adjustable mounting bracket of the exciter lamp is set and locked. Replacement exciter lamps, when installed, will be correctly positioned. A remote **Exciter Lamp Power Supply** provides DC current to the lamp for flicker-free light output.
2. The **Lateral Guide Roller** directs the film path to position the soundtrack in the correct location for scanning. A **Buzz Track** is required for this adjustment.
3. The **Slit Lens** projects the image of the exciter lamp filament to the soundtrack of the film. The **Azimuth** and **Focus** of the slit lens is set and locked. These adjustments require use of **9 kHz** test film.
4. The type and positioning of the **Solar Cell** is determined by the type of sound processing equipment connected to the soundhead. The solar cell collects the pulsating light pattern defined by the slit lens and converts the information into electrical current. A solar cell used with a monophonic sound system is positioned approximately 9/16" (14mm) behind the film plane and outputs (1) channel. A split solar cell is used for SVA (Stereo Variable Area) sound processors. It is positioned no less than 3/16" (5mm) behind the film plane, and outputs (2) channels (left and right).

### REVERSE-SCANNING SOUNDHEADS:

1. The **Lateral Guide Roller** directs the film path to position the soundtrack in the correct location for scanning.
2. A **L.E.D.** (Light Emitting Diode) is positioned directly behind the film plane to illuminate the soundtrack. The horizontal position relative to the soundtrack, and the distance from the film, are set and locked. The L.E.D. is powered by a remote, low-voltage power supply.
3. A **Signal Pick-Up Assembly** is mounted in front of the film plane, and contains the lensing, the solar cells, and terminals for the cell output. All Analog Signal Pick-Up assemblies are configured for SVA optical stereo. This assembly is factory-set to maximize the reception of the signal transmitted by the L.E.D.

## CENTURY REVERSE-SCANNING SOUNDHEADS

Reverse-Scanning Optics, using an infrared L.E.D. (Light Emitting Diode) as a light source, were adopted by Strong International in 1995. A visible-red L.E.D. was adopted in 1997. The L.E.D. features a much longer life (15,000 hours) than an exciter lamp, and eliminates signal loss because of sagging or aging bulb filaments. The one-piece Signal Pick-Up detects only red or infrared inputs, and stray booth lighting does not distort the solar cell output. Channel separation is enhanced by incorporating the solar cells within the sealed lens assembly. Reverse-Scanning soundheads are identified by a /SR suffix on the Equipment Type designation.

The duty cycle (time ON) of the L.E.D. should parallel that of the xenon bulb; the lamphouse elapsed hour meter should approximate L.E.D. hours. L.E.D. manufacturers have noted a 10-20% drop in light output after prolonged (10 year) operation. If a sound signal loss cannot be corrected by fader gain, it may be necessary to replace the L.E.D. Illuminator.

Traditional Direct-Scanning Optics remain available and may be specified on the original equipment order. The exciter lamp DC power supply required for use with the direct-scanning soundhead must be ordered separately; the L.E.D. power supply required for reverse-scanning optics is included with the system. Power supplies of either type are mounted and wired remotely from the soundhead.

Century Direct-Scanning Soundheads (R3, MR3) already in service can be readily converted to Reverse-Scanning Optics by the installation of Reverse Scan Kits:

- 81-98411 Reverse-Scanning Soundhead Conversion Kit, Analog
- 81-98412 Reverse-Scanning Soundhead Conversion Kit, Analog; Digital Convertible
- 81-98413 Reverse-Scanning Soundhead Conversion Kit, Digital (Dolby SR·D)

Replacement L.E.D. (light source) Heads are easily mounted to the Illuminator Bracket and may be installed upon output decrease or failure of the L.E.D.

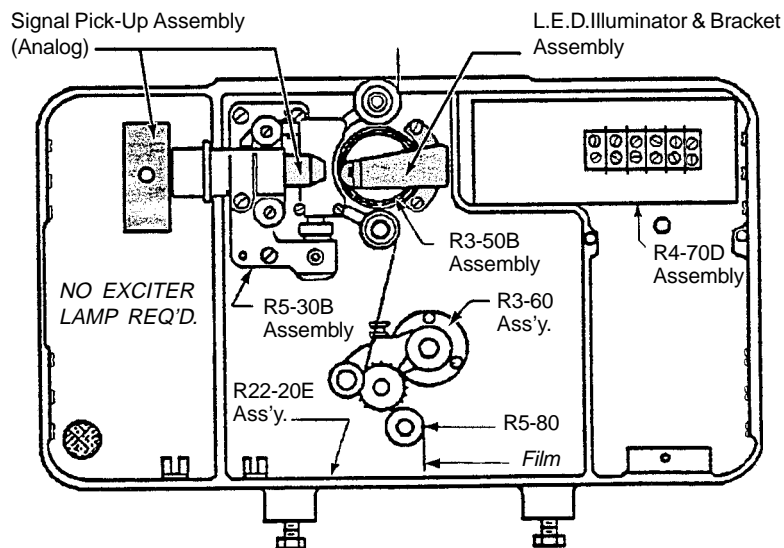

## WIRING & ALIGNMENT

### Reverse Scan Sound Reader

Install the L.E.D. Power Supply to the projection console or to a rack adjacent to the soundhead. Mounting brackets should be specified on the original equipment order; 51-06026 for Rack Mounting, 51-06030 for Console Mounting. Route the power leads to the soundhead-mounted L.E.D. Illuminator Assembly using 18 gauge wires for short runs; 16 gauge wires for excessively long runs.

Pre-amp connections to the analog Signal Pick-Up are made to the clearly marked terminals on the back of the unit. These connections include:

<u>Power Input</u>	<u>Solar Cell Output</u>
12 V.DC +	Right Channel "HI"
12 V.DC -	Right Channel "LO"
Ground	Ground (Shield)
	Left Channel "HI"
	Left Channel "LO"

It is recommended to use (2) shielded two-conductor cables to connect the solar cell outputs, but use of a three-conductor, single-shield cable is permitted. If using three-conductor cable, strap the two "LO" terminals together. Since very little current is required, 22 gauge wire is adequate. DO NOT interconnect *input* and *output* grounds.

### ADJUSTMENTS (Analog):

Energize the L.E.D. and connect test equipment to Solar Cell Output terminals. Turn the sound processor's *level* and *high frequency* adjustment to minimum settings.

Loosen, but do not remove, the socket head screw clamping the analog L.E.D. head to its mounting post and bracket. Loosening this screw permits moving the L.E.D. head up and down, and on the horizontal plane (in and out). Position the L.E.D. to visually locate the light directly opposite the lens opening of the Signal Pick-Up Assembly. Run a loop of *level set* ("Dolby Tone") film and observe the output of the LEFT and RIGHT channels. When the highest output is seen, move the L.E.D. head horizontally (in and out) in the impedance drum. DO NOT permit the L.E.D. head to touch the inside of the impedance drum. Observe the output and securely tighten the L.E.D. head clamping screw when the highest output is achieved.

Run a "Buzz Track" (SMPTE No. 35-BT) loop and set the lateral guide roller as required. It is recommended to splice together a loop of half "Buzz Track" film and half "Left/Right Alignment" (Dolby Cat. No. 97) film. This permits centering the soundtrack and checking for cross-talk simultaneously.

Set the focus and azimuth by running the 9 kHz. loop and adjusting the Signal Pick-Up Assembly in the same manner as a conventional slit lens. Finalize the A-Chain installation by again checking the L.E.D. adjustment, and performing a final "Dolby" level set. Run a "Pink Noise" loop for equalization, and perform any other steps specified by the manufacturer of the processor.

## ADJUSTMENTS (Digital):

Perform the above procedure, but do not consider the analog installation complete until also setting the digital scanning components. In order to best accommodate the scanning of TWO soundtracks, some fine adjustments to the analog scanning will be re-set in the course of digital alignment.

The visible L.E.D. Dual Reader is supplied with the LS-30 Modular Power Supply. The LS-30 contains (2) of the universal power supply modules. The output adjustments, however, are wired to the chassis, so the modules can be interchanged without resetting the output level.

- The *left* unit is factory set at 450 mA. to power the *analog* L.E.D. The *right* unit is set at 550 mA. to power the *digital* L.E.D.
- The L.E.D.'s are bipolar; the power supply cannot damage an L.E.D. through reversed polarity. It is safe to try reversing the polarity if you have power but no light. **Accidental connection of the L.E.D. to the pre-amp power terminals will damage the L.E.D.**
- The L.E.D. and pre-amp wiring terminals, the output adjustments, and the AC line voltage selector switch are all located on the back plane of the LS-30 cabinet. **Carefully inspect the connections and settings before powering up the LS-30.** See the illustration below.
- Power supply module fuses are accessible by removing the module from the chassis.
- The pre-amp power to the analog reader (Signal Pick-Up) is 12 V.DC+, ground, and 12 V.DC-. The ground *must* be connected at both ends as it is circuit reference zero volts.

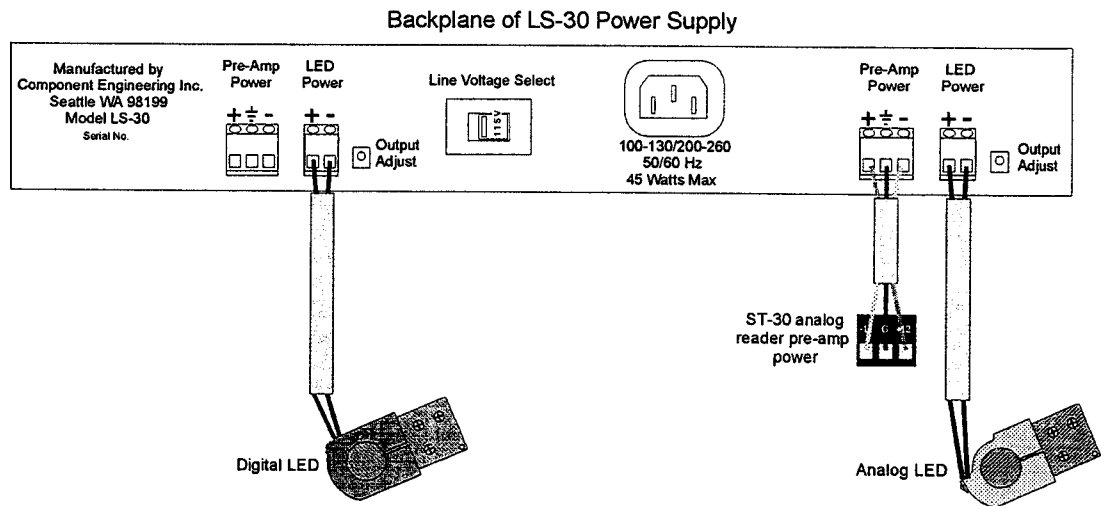



### *Preliminary Adjustment*

- Power up the LS-30 Power Supply and the Audio Processor.
- Observe that both L.E.D.'s emit visible light.
- Connect a dual-trace oscilloscope to the left and right test points of the processor pre-amp.
- Thread and run Dolby *Tone Test* film (Cat. No. 96t).
- Observe oscilloscope traces and "Dolby" level indicators in the processor.
- If tone is visible on both channels, set to "Dolby" level.
- If not, check L.E.D. alignment and focus the optics. Then set "Dolby" level.
- Thread and run SMPTE "Buzz" track.
- Adjust lateral guide roller as required to obtain (2) very low, equal residual signals.

### *Analog L.E.D. Alignment*

The analog L.E.D. must be aligned before the digital.

- Turn both *left* and *right* channel pre-amp gain adjustments on your cinema processor to FULL DOWN; if using a Dolby CP-500, turn to 50%. The goal is to have equal gain on both channels.
- Thread and run Dolby *Tone Test* film (Cat. No. 96t).
- View the pre-amp outputs on the oscilloscope screen.
- Rotate the L.E.D. mount assembly to reach the maximum amplitude of both traces.
- Move the assembly laterally to get both traces as high and equal as possible.
- Complete the standard "A" chain alignment.

### **To minimize microphonics, the L.E.D. must be very accurately aligned.**

- With the power amplifiers OFF, turn the processor and monitor gains FULL UP. Select a film format and the correct projector on the processor. Run the projector with no film. Fine-adjust the L.E.D. mount rotation to a point where the sound of the projector running is not heard through the sound system. The optimal adjustment will be found *between* two positions where the projector vibration can be heard quite clearly. Run Dolby *Tone* again to give the system a final adjustment. The final result will be projector noise that is below the noise floor of the processor.
- Optionally, connect an AC millivolt meter to one of the pre-amp test points. Rotate the L.E.D. mount to achieve highest output to three decimal places on the AC millivolt meter. Careful peaking will achieve the same result.

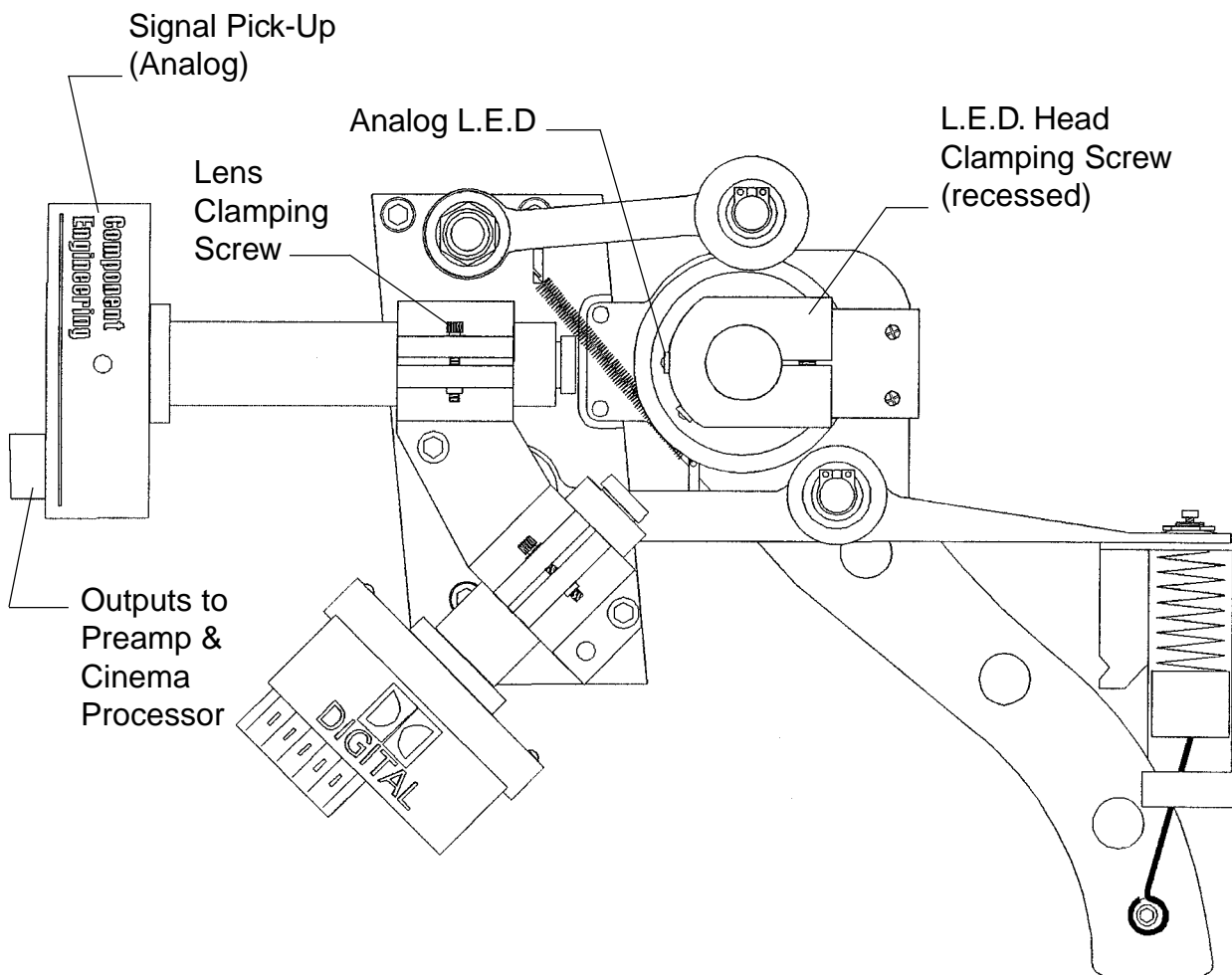

*Digital Reader Alignment*

- Thread and run a reel of Dolby-encoded film.
- Connect a dual-trace oscilloscope to the Dolby Digital Processor per the following instructions.
- Refer to the oscilloscope traces below in reference to the following instructions:

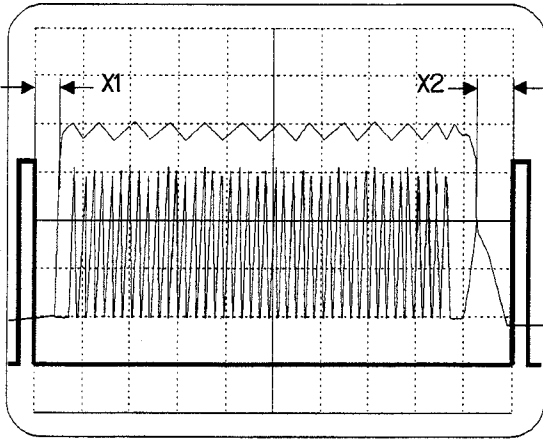

A

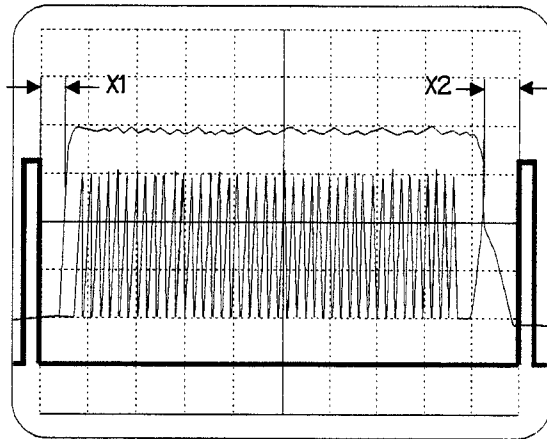

B

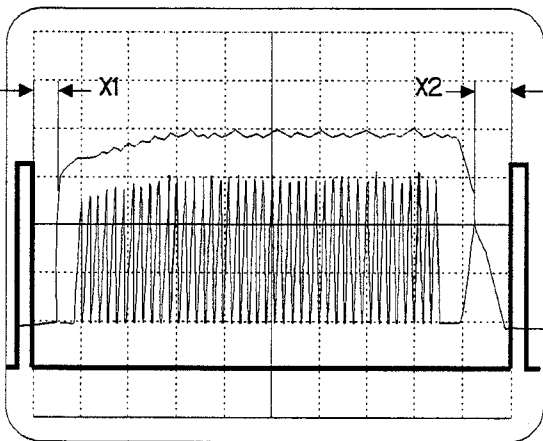

C

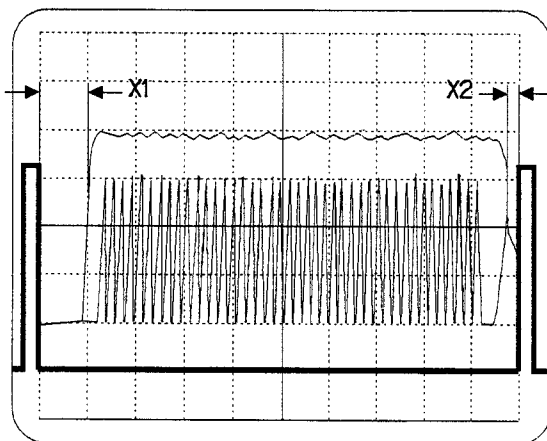

D

**Figure B is in optimal alignment.**

- In Figure A, the top of the sprocket hole has (12) large saw teeth. The differential between the high and low points is 1/3 volt.
- Figure B shows more saw teeth with less differential. This is obtained by fine-adjusting the rotation of the L.E.D. holder.
- In Figure C, the sprocket hole is falling off on the left, indicating uneven light. This is improved by moving the L.E.D. holder laterally until a flatter trace is obtained.
- In Figure D, the CCD board is misaligned laterally. Dimension X2 is smaller than X1. This can be improved by loosening the (2) CCD board mounting screws and moving the board until the X1 and X2 dimensions look like Figure B.

The correct alignment is offset to the left by one minor division. That is, the sprocket hole will be 1/5 of a square off-center toward the left "goal post" on the 'scope screen.

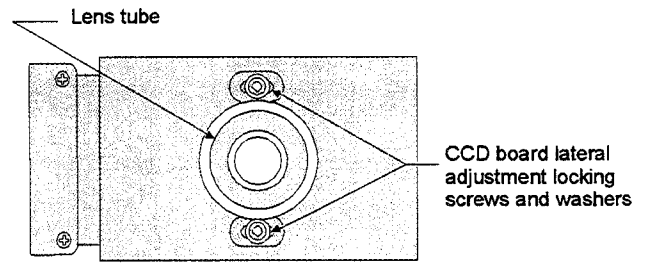

**digital lens and pre-amp**

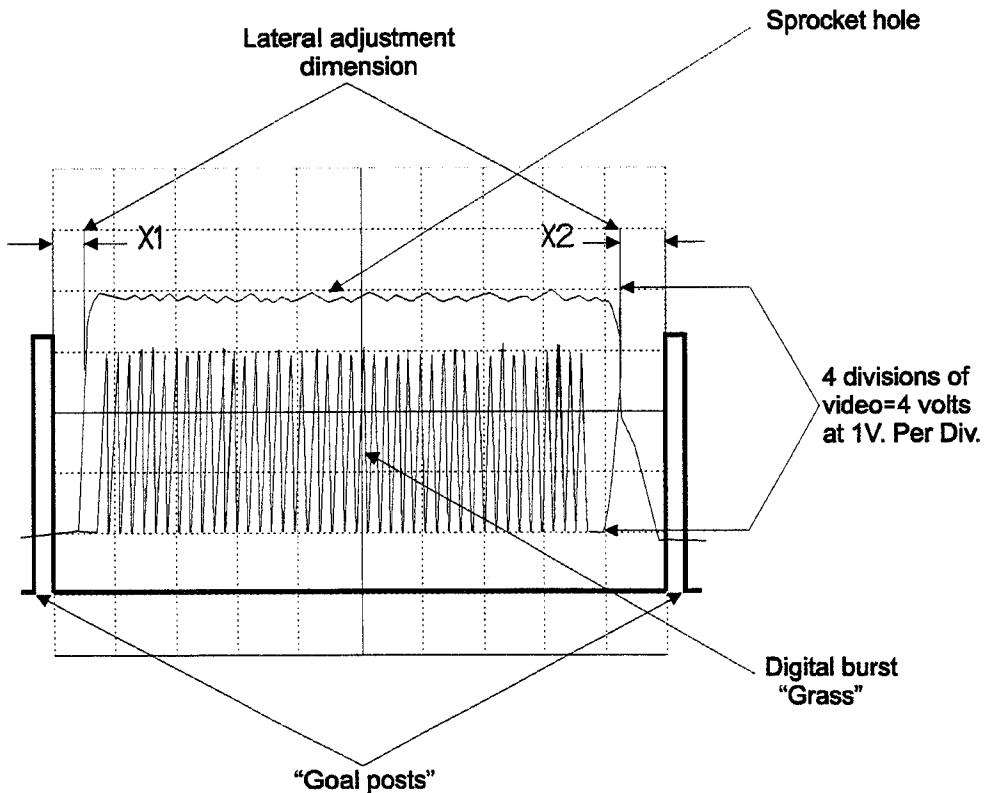

## Instructions for Alignment of Readers for Dolby Digital

1. **Connect a dual-trace oscilloscope** to test points on Video Acquisition Card (Cat. No. 605 or 670). Oscilloscope should be 20 MHz. minimum.
  - a) Connect Channel 1 to **Video** test point; connect this probe ground only to **Gnd.** test point.
  - b) Connect Channel 2 to **Clamp** test point.
  - c) Set both channels *Volt/Div.* controls to 1 volt/div. Set vernier to calibrate. Ensure that probes are *not* at X10.
  - d) Set horizontal sweep rate to 2 usec/div.
  - e) Set trigger to channel 2 and positive polarity, adjust trigger level, and lock on signal.
2. **Calibrate oscilloscope to processor:**
  - a) Thread a loop of Cat. No. 69P test film into projector and reader; start machine.
  - b) Select Channel 2 for display.
  - c) Adjust the horizontal position to line up the inside edge of the left “goal post” with the left edge of the graticule.
  - d) Adjust the sweep vernier to line up the inside edge of the right “goal post” with the right edge of the graticule.
  - e) Adjust the vertical position for the baseline of the clamp signal (Channel 2) to coincide with a line in the lower section of the graticule.
  - f) Select either *Alternate* or *Chop* to give the brightest display of both channels.
  - g) Adjust the vertical position of the video signal (Channel 1) to coincide with the same line as the clamp signal.
3. **Alignment of the Reader:**
  - a) Loosen the lateral adjustment locking screws and roughly adjust the lateral position of the CCD board so that the outer trace (perf) is centered between the “goal posts.” This is approximate, and will be repeated later for accurate positioning. Retighten screws.
  - b) Rotate the L.E.D. mounting assembly for maximum amplitude on the upper trace without sacrificing flatness. The trace should vary one block or less ( $\pm .5$  volt). As shown, Figure B is improved from Figure C. Amplitude, as measured with the top trace, should be between 2-5 volts from baseline. Adjust the digital L.E.D. for minimum ripple on the upper trace of the video signal. As shown, Figure B is improved from Figure A.
  - c) If available, use DRAS10 software and a laptop computer to view the adjustment of azimuth for a zero degree reading. Or, center the reader rotation between sync lost points using the error rate of the Digital Processor to indicate lost sync.
  - d) Adjust focus for darkest center in area of bits (grass). Confirm highest reading with DRAS.
  - e) Confirm calibration of oscilloscope as above. Readjust the lateral position to align the outer trace to one minor division (2/10) left of center between the “goal posts.” Figure B is improved from Figure D.
4. **Final Analog:**

Check the lateral alignment, as initially set using the “Buzz Track,” and correct as required. Confirm the L.E.D. positioning by setting the oscilloscope for “X-Y” display and running the Dolby Cat. No. 97 loop. A “cross” should appear on the screen. When both the horizontal and vertical lines are straight and of uniform length, the optimum position has been reached. Repeat the tests for focus, azimuth, equalization, and “Dolby” level set. A difference may be noted in that the high frequency range is extended, and very little high frequency boost will be required.

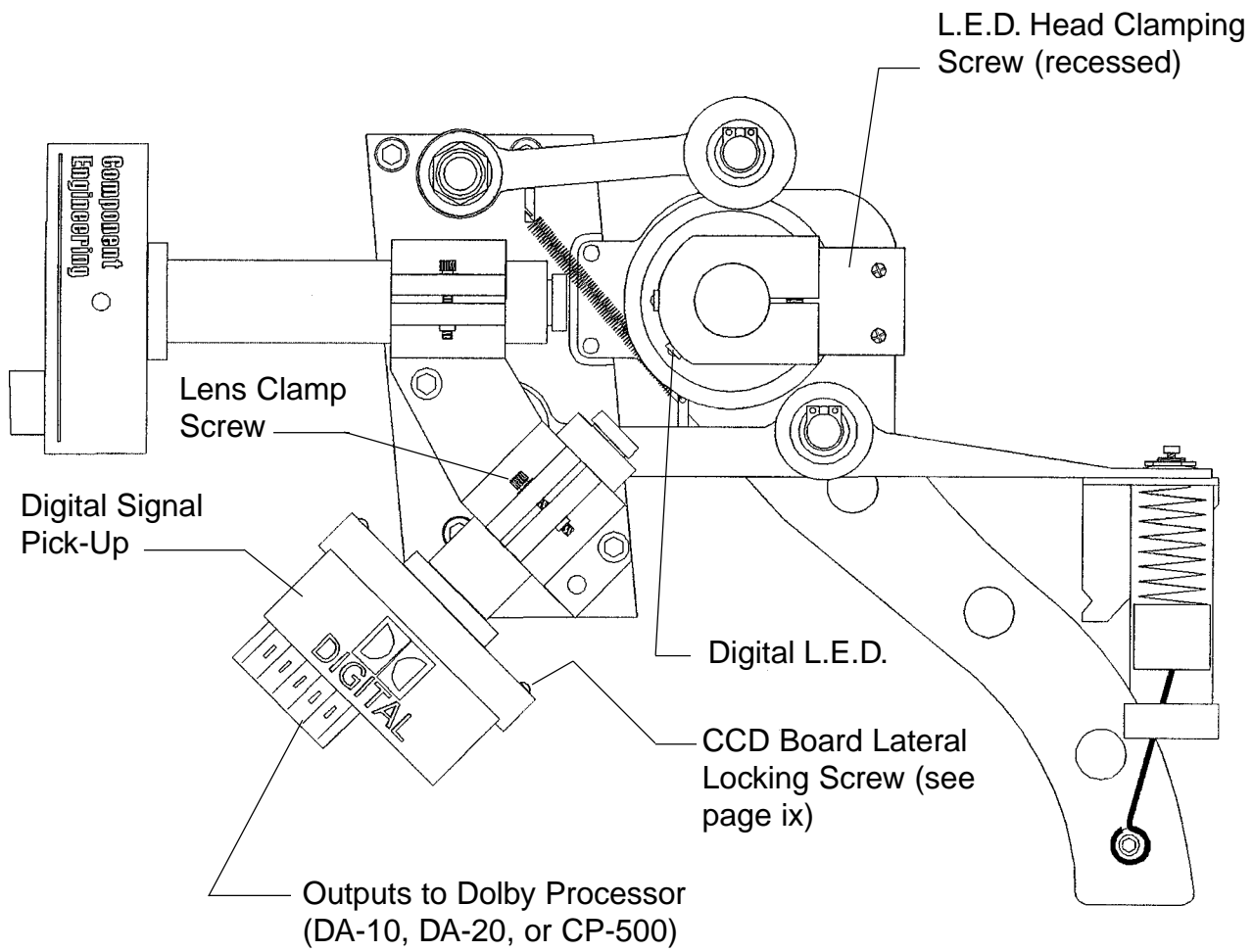

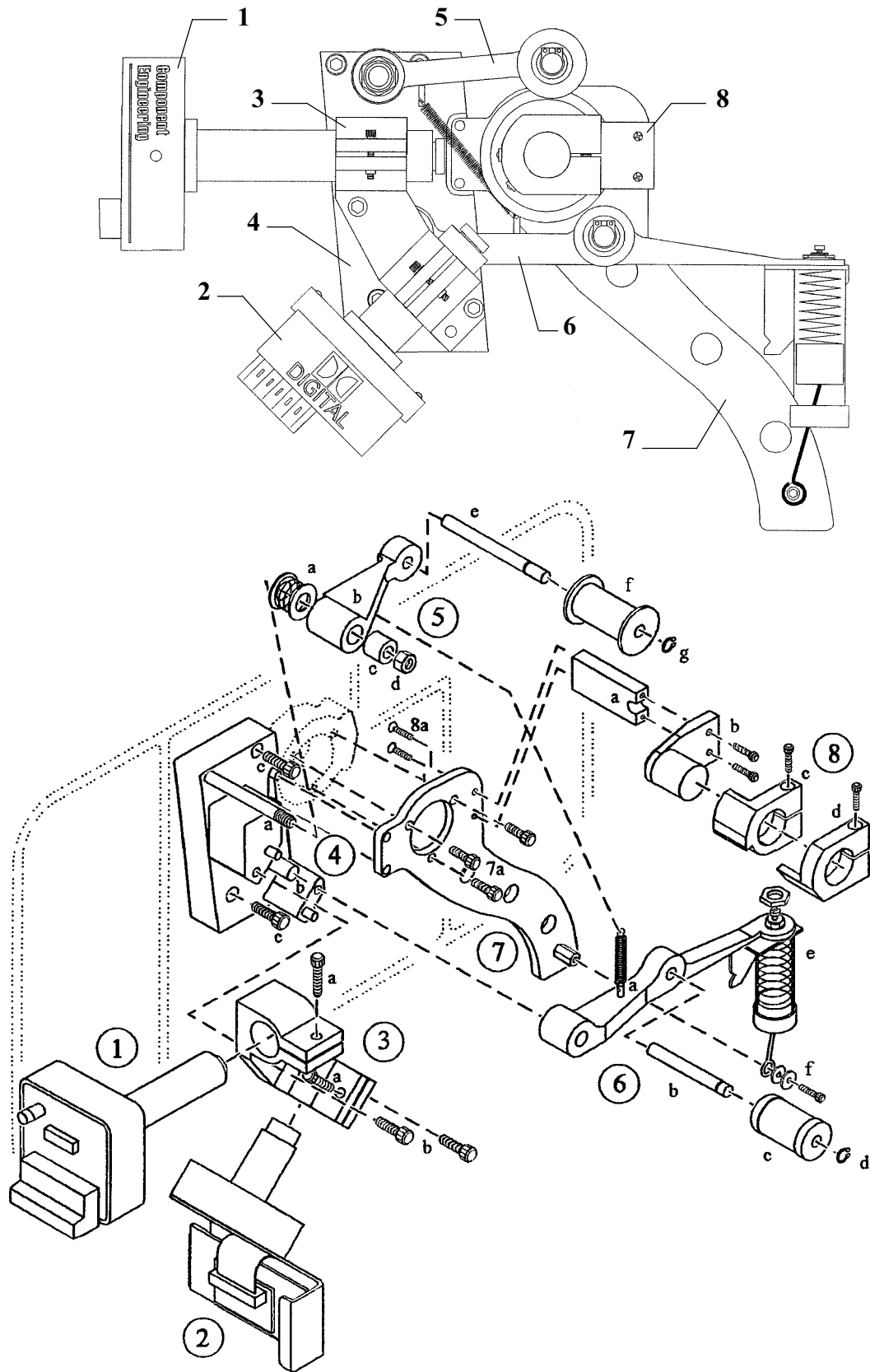

## PARTS LIST

<u>Item</u>	<u>Part No.</u>	<u>Description</u>
1	51-30001	Signal Pick-Up Assembly, Analog
2	51-30002	Signal Pick-Up Assembly, Digital
3	81-98439	Lens Tube Bracket
3a	41-51566	Clamping Screw, 8-32 x 3/4"
3b	41-51607	Mounting Screw, 10-32 x 5/8"
4	81-98438	Adapter Block
4a	81-98437	Upper Control Arm Shaft
4b	81-98436	Lower Control Arm Shaft
4c	41-51208	Mounting Screw, 10-32 x 1/2"
5	81-98435	Upper Roller Arm Assembly
5a	81-98434	Spring
5b	81-98433	Arm Casting
5c	81-98432	Bearing
5d	41-35075	Nut, 1/4-20 FlexLock
5e	81-98431	Roller Shaft
5f	91-98430	Roller
5g	21-48016	Snap Ring
6	91-98443	Lower Roller Arm Assembly
6a	81-98442	Arm Casting
6b	81-98441	Roller Shaft
6c	91-98440	Roller
6d	21-48016	Snap Ring
6e	81-98429	Damper
6f	41-51325	Screw, 6-32 x 3/8"
-	41-70001	Flatwasher, #6
7	81-98428	Adapter Plate
7a	41-51197	Mounting Screw, 8-32 x 1/2"
8	81-98422	L.E.D. Head Assembly (Analog & Digital, as shown)
8	81-98428	L.E.D. Head Assembly (Analog only)
8a	91-98427	Spacer
8b	81-98426	Stud Plate
-	00165000	Assembly Screw, 6-32 x 3/8" Flat Head
8c	81-98425	L.E.D. Head, Analog
8d	81-98424	L.E.D. Head, Digital
-	41-51566	Clamping Screw, L.E.D. Head; 8-32 x 3/4"
-	51-30006	L.E.D. Illuminator



CENTURY SOUNDHEAD, Main Frame Overview

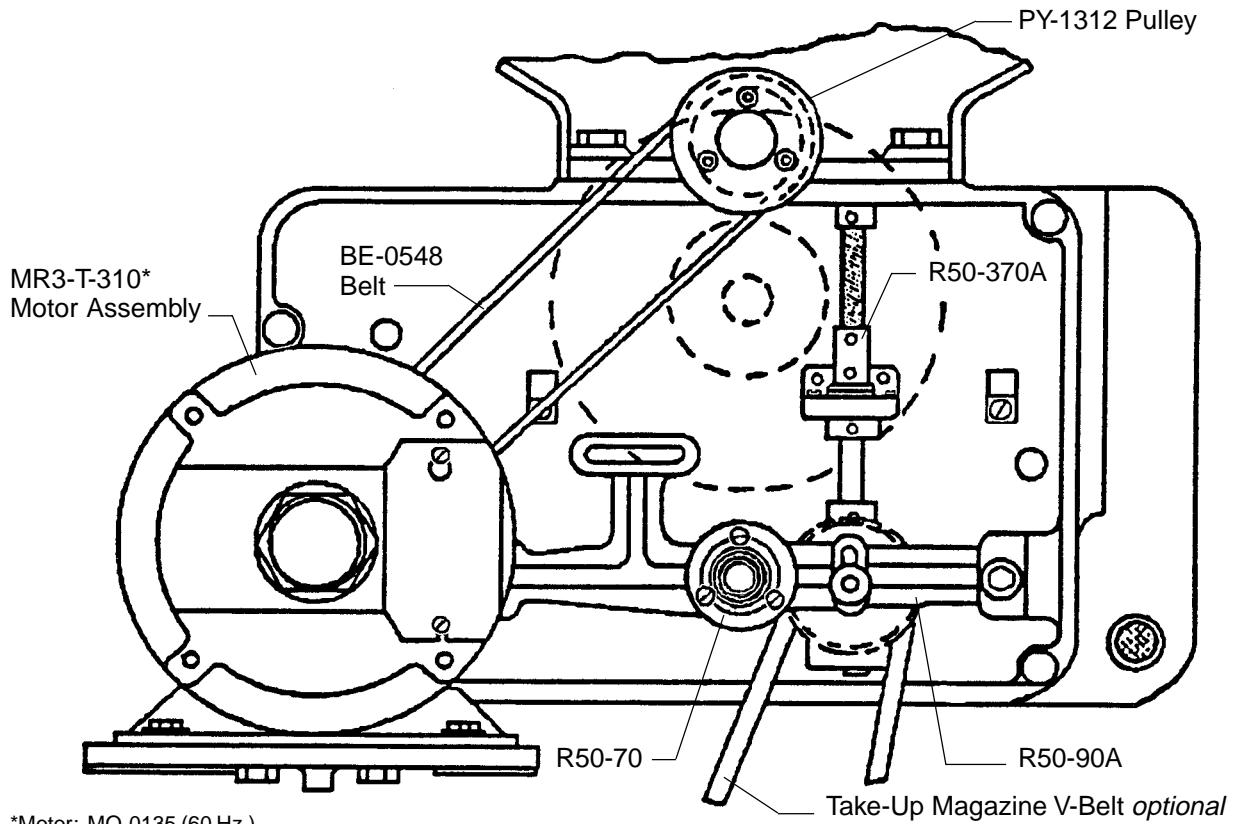

\*Motor: MO-0135 (60 Hz.)  
 Motor: 51-33013 (50 Hz.)  
 Flywheel: WH-0251  
 Pulley: PY-1317

MR3 DIRECT DRIVE, Off-Operator Side View  
 (see Pages 21 & 22 for R3 Standard Drive)

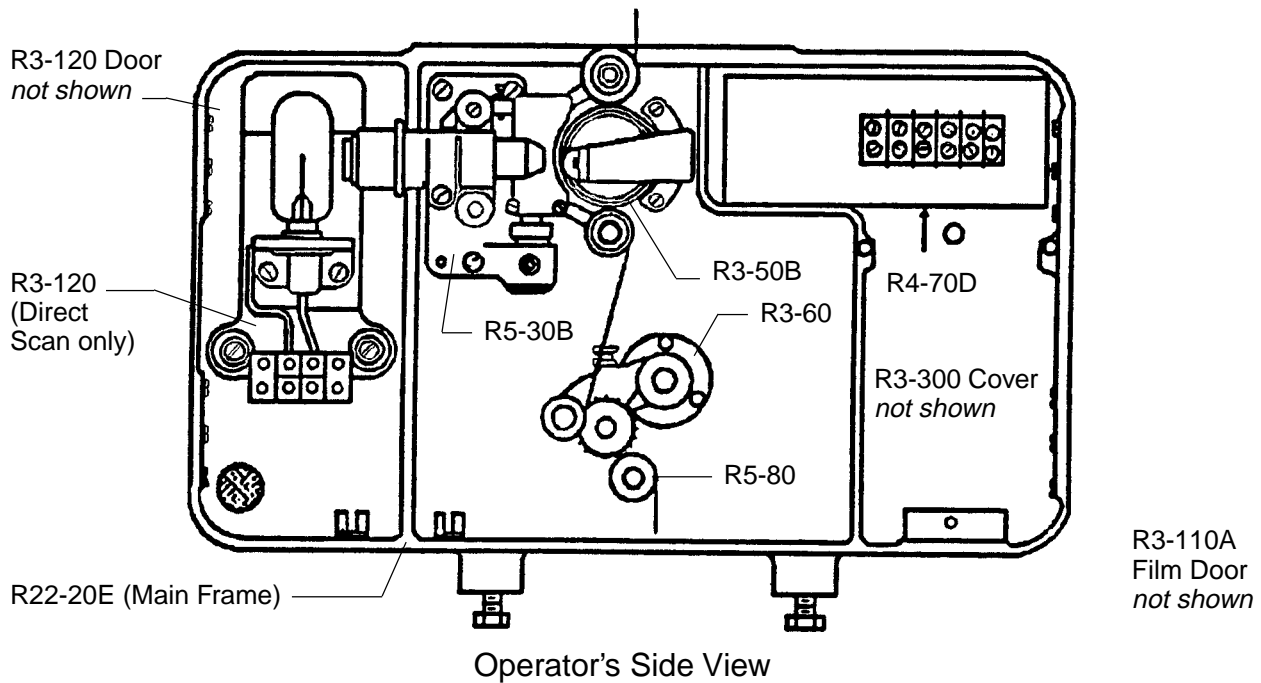

Operator's Side View

## MAIN FRAME & PIN ASSEMBLY (82-60185)

<u>Part No.</u>	<u>Description</u>
R22-20G	Main Frame & Pin Assembly
R4-70D	Terminal Panel Assembly
C1-A-11	Door Hinge (4 req'd.)
C1-A-76	Door Catch & Strike (2 req'd.)
FR-0146	Frame Casting
PE-0219	Nameplate
PG-0608	Hole Plug
41-51061	Bearing Screw, 8-32 x 1/4" Bind Head (3 req'd.)
SC-0226	Screw, Stop Link
41-51459	Drive Screw, Nameplate; #4 x 3/16" (4 req'd.)
41-51065	Screw, 8-32 x 5/16" (12 req'd.)
VE-0003	Vent Plug
KY-0079	Alignment Key
PN-0021	Locating Pin
10274	Front Belt Guard (after Serial No. 7030)

## TERMINAL PANEL ASSEMBLY (82-70032)

<u>Part No.</u>	<u>Description</u>
R4-70D	Terminal Panel Assembly
PE-1289	Plate (Dolby)
41-51365	Screw, 10-32 x 3/8" Socket Head (2 req'd.)
SC-2096	Screw, 6-32 x 3/8" Bind Head (4 req'd.)
21-62003	Barrier Strip, (4) Terminal
	<i>Associated Parts</i>
SC-0564	Projector Mounting Screw, 3/8-16 (4 req'd.)
41-51138	Mounting Screw, Take-Up; 5/16-18 (4 req'd.)
SC-0599	Mounting Screw, Soundhead; Short (4 req'd.)
WA-0105	Washer, Soundhead Mounting Screw

## SIGNAL PICK-UP & BRACKET ASSEMBLY (Direct Scan)

81-98062	Split Solar Cell Assembly See Page <b>xii</b> for Reverse Scan Parts
----------	---

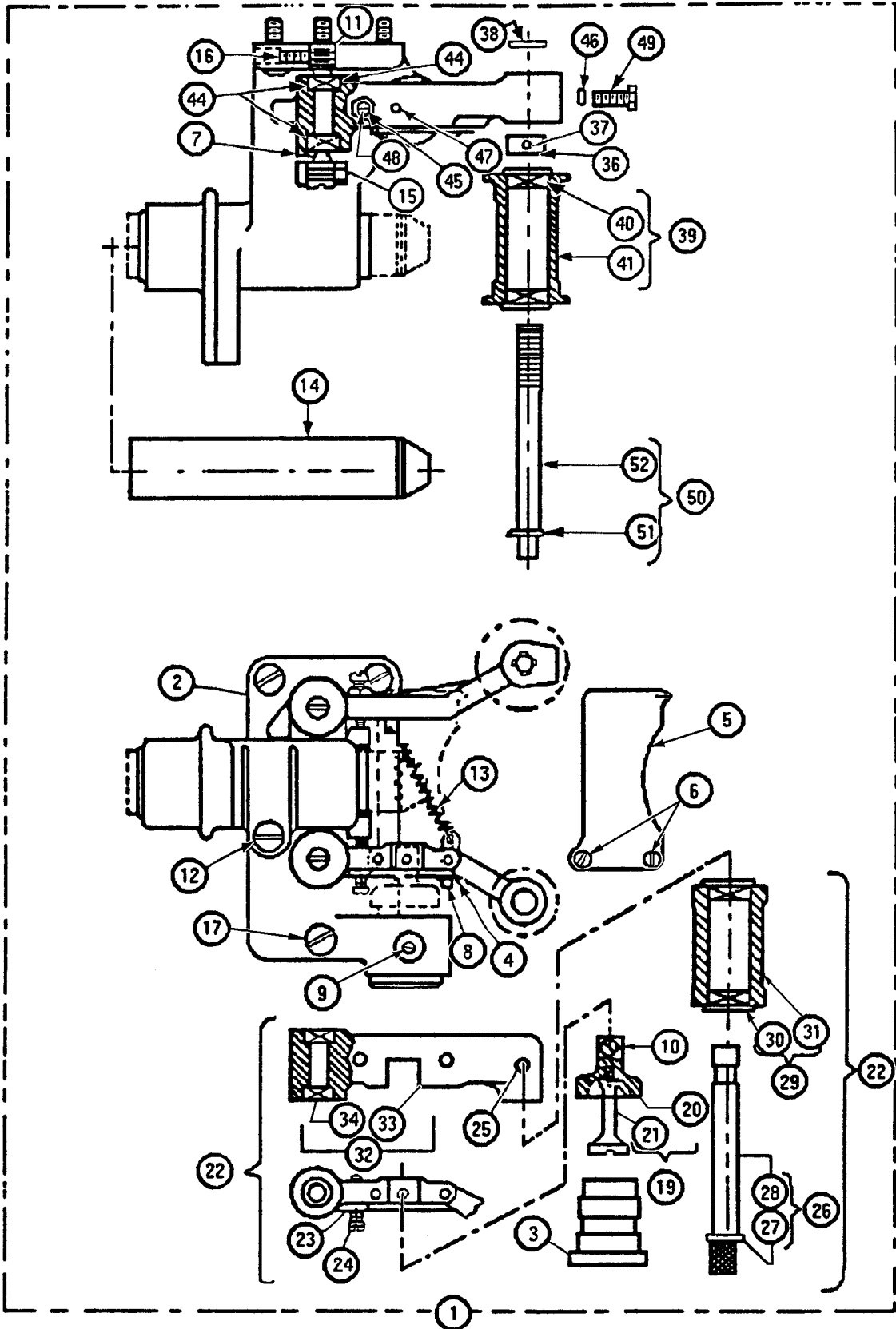

## DAMPER ASSEMBLY (82-60087)

<u>Item</u>	<u>Part No.</u>	<u>Description</u>
1	R5-30B R3-35 R5-33 R5-50	Damper Assembly Cover & Plunger Lower Damper Arm Upper Damper
2	BR-0117	Damper Bracket
3	CU-0085	Cup
4	41-35072	Adjusting Nut, 4-40 Esna
5	PE-0118	Indicating Plate
6	SC-0096	Indicator Screw, 4-40 x 1/8" (2 req'd.)
7	SC-2447	Pivot Screw, 5/16-24 x 1/2" (2 req'd.)
8	SC-0519	Adjusting Screw
9	H-3719	Cup Set Screw, 8-32 x 1/8"
10	SC-0550	Pivot Screw
11	SC-2446	Damper Arm Screw (2 req'd.)
12	00386000	Lens Clamping Screw, 10-32 x 1/2" Fillister Head
13	SG-0591	Damper Spring
14	P-2320	Slit Lens (Direct Scan <i>only</i> ) .6 mil
-	P-2320A	Slit Lens, Studio; .47 mil
15	SC-2445	Pivot Retaining Screw, 6-32 x 1/4" (2 req'd.)
16	SC-2450	Pivot Retaining Screw, 6-32 x 3/8" (2 req'd.)
		<i>Associated Parts</i>
17	00386000	Assembly Mounting Screw (3 req'd.)
18	FD-0120	Damping Fluid (not shown)

## OIL COVER & PLUNGER ASSEMBLY (82-60131)

<u>Item</u>	<u>Part No.</u>	<u>Description</u>
19	R3-35	Damper Plunger Assembly
20	CR-0083	Cover
21	PU-0116	Plunger

## LOWER DAMPER ARM ASSEMBLY (82-60139)

<u>Item</u>	<u>Part No.</u>	<u>Description</u>
22	R5-33 R5-31 R5-36 R5-38	Lower Damper Arm Assembly Stud & Retaining Ring Assembly Roller & Bearing Assembly Arm & Bearing Assembly
23	41-35002	Adjusting Nut, 4-40
24	41-51379	Adjusting Screw, 4-40 x 1/2" Fillister Head
25	H-3719	Stud Set Screw, 8-32 x 1/8"

LOWER DAMPER ROLLER STUD & RETAINING RING ASSEMBLY (82-60063)

<u>Item</u>	<u>Part No.</u>	<u>Description</u>
26	R5-31	Stud & Ring Assembly
27	2933	Retaining Ring
28	SU-2167	Stud

LOWER DAMPER ROLLER & BALL BEARING ASSEMBLY (82-60064)

29	R5-36	Roller & Bearing Assembly
30	BR-1149-A	Ball Bearing (2 req'd.)
31	RO-0551	Lower Roller

LOWER DAMPER ARM & BALL BEARING ASSEMBLY (82-60140)

32	R5-38	Arm & Bearing Assembly
33	AR-0034	Arm Casting
34	BG-0099	Ball Bearing (2 req'd.)

UPPER DAMPER ARM ASSEMBLY (82-60204)

<u>Item</u>	<u>Part No.</u>	<u>Description</u>
35	R5-50	Upper Damper Arm Assembly
	R5-37	Roller & Bearing Assembly
	R5-51	Damper Arm Assembly
	R5-52	Arm Stud & Ring Assembly
36	CL-0084	Thrust Collar
37	SC-0578	Collar Fastener Set Screw, 4-40 x 1/8"
38	RI-0550	"E" Ring

UPPER DAMPER ROLLER & BALL BEARING ASSEMBLY (82-60065)

<u>Item</u>	<u>Part No.</u>	<u>Description</u>
39	R5-37	Roller & Bearing Assembly
40	BG-1149-A	Ball Bearing (2 req'd.)
41	RO-0549	Roller

## UPPER DAMPER ARM & MISCELLANEOUS PARTS (82-60205)

<u>Item</u>	<u>Part No.</u>	<u>Description</u>
42	R5-51	Arm Assembly
43*	AR-0198	Upper Arm
44*	BG-0099	Ball Bearing (2 req'd.)
45*	41-35002	Lock Nut, 4-40 Esna
46*	PG-0013	Fibre Plug
47*	SU-0554	Stud
48*	41-51379	Stop Screw, 4-40 x 1/2" Fillister Head
49*	SC-2434	Screw, 8-32 x 3/8" Hex Head
	* Order R5-51	

## UPPER DAMPER ARM STUD & RETAINING STUD RING (82-60142)

<u>Item</u>	<u>Part No.</u>	<u>Description</u>
50	R5-52	Stud & Ring Assembly
51	2933	Retaining Ring
52	SU-2298	Stud, Grooved

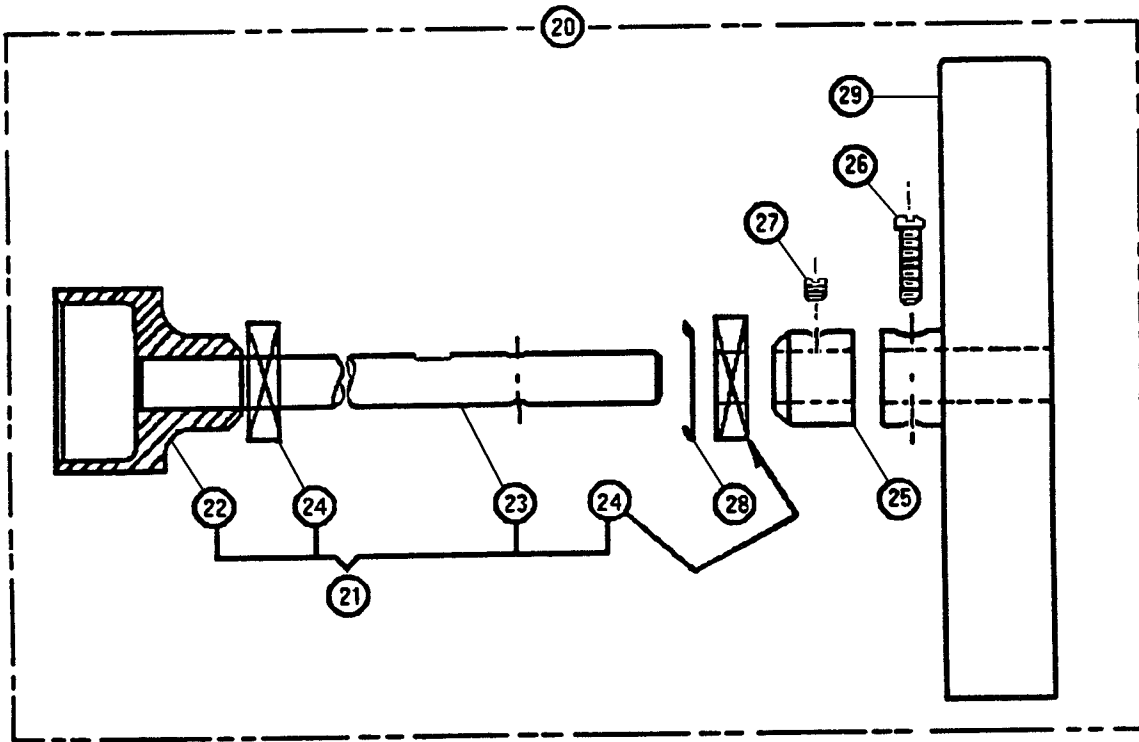
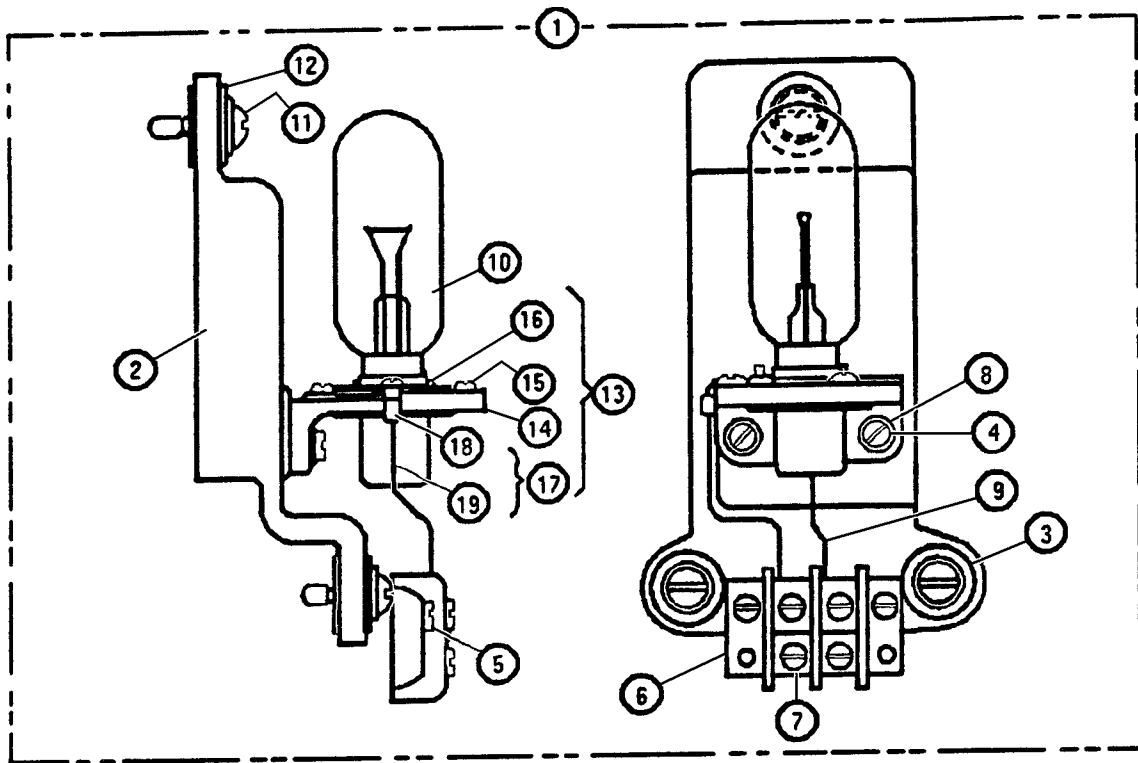

EXCITER LAMP ASSEMBLY (82-60132) *Direct Scan Models only*

<u>Item</u>	<u>Part No.</u>	<u>Description</u>
1	R5-40	Exciter Lamp Assembly
	R3-41	Socket & Bracket Assembly
2	BA-0125	Base Casting
3	GM-0051	Grommet (3 req'd.)
4	00256000	Mounting Screw, 8-32 x 3/8" Fillister Head (2 req'd.)
5	SC-2158	Strip Mounting Screw, 5-40 x 1/2" Bind Head (2 req'd.)
6	39184R00	Barrier Strip, (2) Terminal
7	TE-0274	Terminal (8 req'd.)
8	41-70002	Washer, #8 (2 req'd.)
9	R3-47	Wire Assembly
		<i>Associated Parts</i>
10	7-16	Exciter Bulb, 9 V. 4 A.
11	SC-2521	Base Mounting Screw (3 req'd.)
12	WA-0142	Washer

EXCITER LAMP SOCKET & BRACKET ASSEMBLY (82-70031)

<u>Item</u>	<u>Part No.</u>	<u>Description</u>
13	R3-41	Socket & Bracket Assembly
	R3-43	Ground Wire & Lug
14	BR-0124	Bracket
15	SC-0539	Mounting Screw, 5-40 x 1/4" Bind Head
16	SF-0628-BB	Socket

GROUND LEAD WIRE & LUG ASSEMBLY (82-70016)

<u>Item</u>	<u>Part No.</u>	<u>Description</u>
17	R3-43	Ground Wire & Lug Assembly
18	39114000	Lug
19	21-71102	Wire, Green (length as req'd.)



IMPEDANCE DRUM & FLYWHEEL ASSEMBLY (82-60133)

<u>Item</u>	<u>Part No.</u>	<u>Description</u>
20	R3-50A	Impedance Drum & Flywheel Assembly
21	R3-51A*	Drum, Shaft, & Bearing Assembly
22	DR-0133*	Impedance Drum
23	ST-0546*	Shaft
24	BG-0726A*	Ball Bearing (2 req'd.)
25	CL-0082	Thrust Collar
26	00390000	Flywheel Screw, 10-32 x 3/4" Fillister Head
27	SC-1236	Set Screw, 10-32 x 3/16"
28	SG-0943	Loading Spring
29	WH-0072	Flywheel

\* Order R3-50A less WH-0072

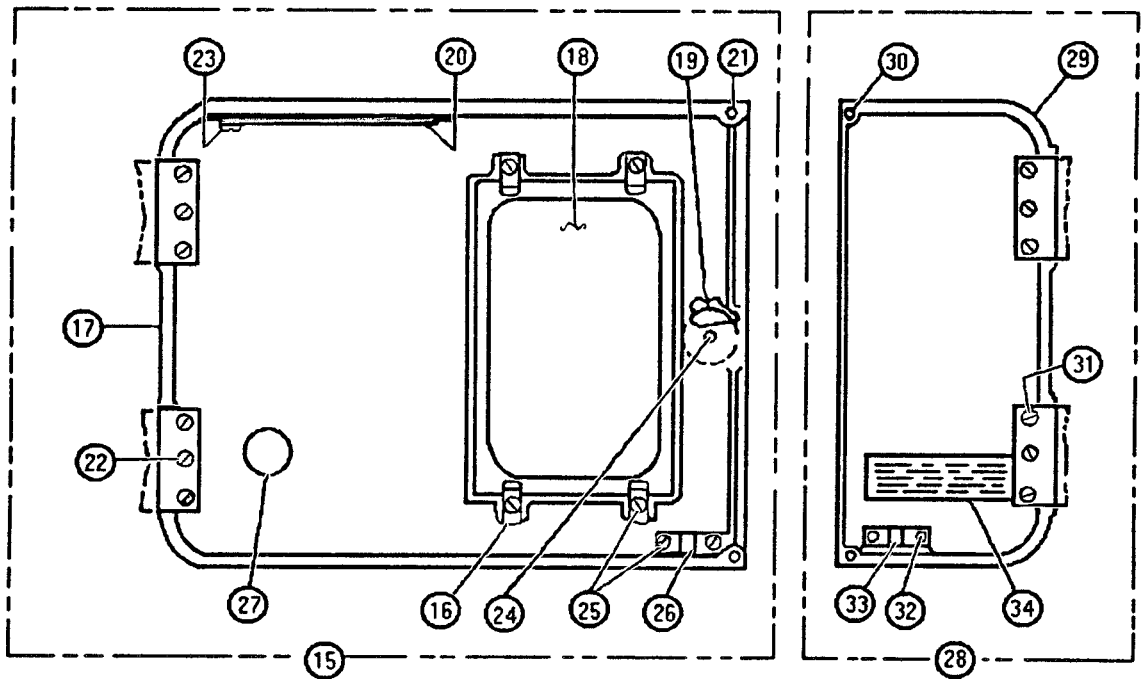
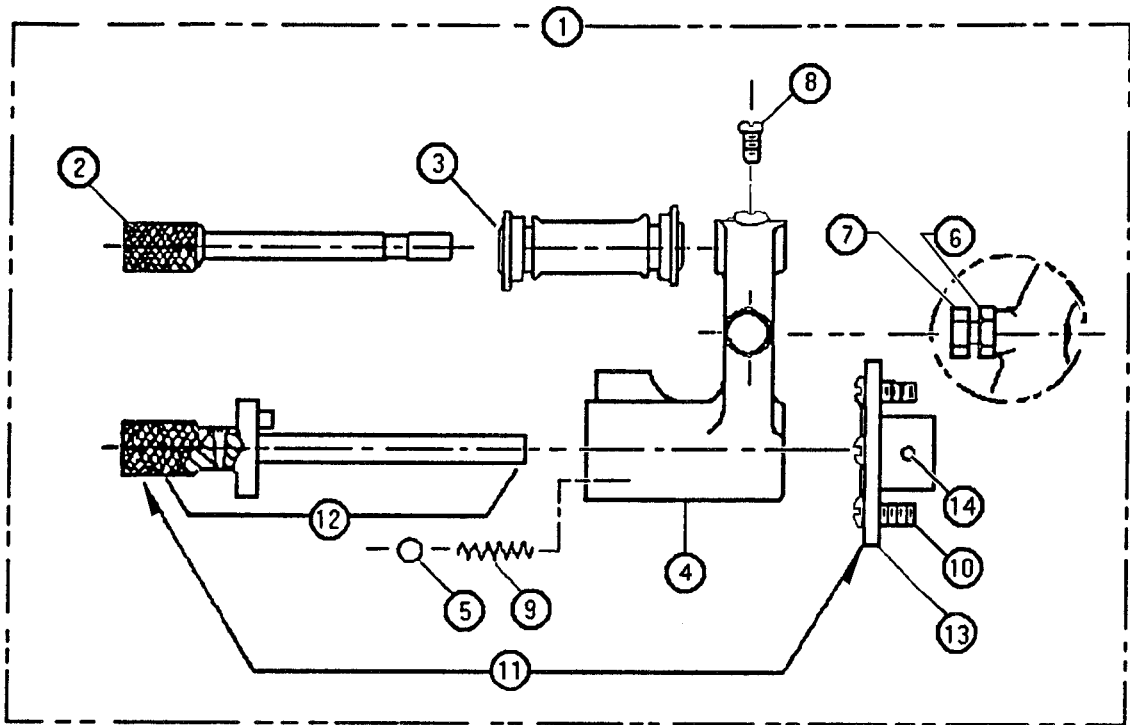

PAD ROLLER ARM ASSEMBLY (82-60134)

<u>Item</u>	<u>Part No.</u>	<u>Description</u>
1	R3-60	Pad Roller Arm Assembly
2	C1-C-21	Shaft & Knob
	R2-31	Pad Roller Stud
3	R3-400	Pad Roller
4	AR-0033	Arm Casting
5	2908	Detent Ball (2 req'd.)
6	NU-0008	Lock Nut, 8-32
7	SC-0087	Adjusting Screw, 8-32 x 7/8" Hex Head
8	41-51416	Stud Retaining Screw, 6-32 x 3/8" Hex Head
9	SG-0021	Detent Spring (2 req'd.)
		<i>Associated Parts</i>
10	00256000	Mounting Screw, 8-32 x 3/8" Fillister Head (3 req'd.)

PAD ROLLER STUD, KNOB & FLANGE ASSEMBLY (82-20298)

<u>Item</u>	<u>Part No.</u>	<u>Description</u>
11	R2-31	Stud, Knob, & Flange Assembly
12	R2-32*	Stud & Knob
13	FL-0008*	Flange
14	PN-0103*	Taper Pin
	* Order R2-31	

FILM COMPARTMENT DOOR ASSEMBLY (82-60054)

<u>Item</u>	<u>Part No.</u>	<u>Description</u>
15	R3-110A	Film Compartment Door Assembly
16	CP-0020	Glass Clamp (4 req'd.)
17	DO-0017	Door Casting
18	GL-0108	Window Glass
19	KN-0047	Pull Knob
20	LI-0007	Door Link
21	SB-0060	Cushion, Felt (2 req'd.)
22	41-51061	Hinge Screw, 8-32 x 1/4" Bind Head (6 req'd.)
23	SC-0226	Link Screw
24	41-51073	Knob Screw, 8-32 x 1/2" Bind Head
25	SC-0123	Mounting Screw, 6-32 x 3/16" Bind Head (6 req'd.)
26	C1-A-76	Door Catch
27	PG-0608	Hole Plug

## EXCITER COMPARTMENT DOOR ASSEMBLY (82-60055)

<u>Item</u>	<u>Part No.</u>	<u>Description</u>
28	R3-120	Exciter Lamp Compartment Door Assembly
29	DO-0016	Door Casting
30	SB-0060	Cushion, Felt (2 req'd.)
31	41-51061	Hinge Screw, 8-32 x 1/4" Bind Head (6 req'd.)
32	SC-0123	Strike Screw (2 req'd.)
33	C1-A-76	Door Catch
34	DC-0019	Decal

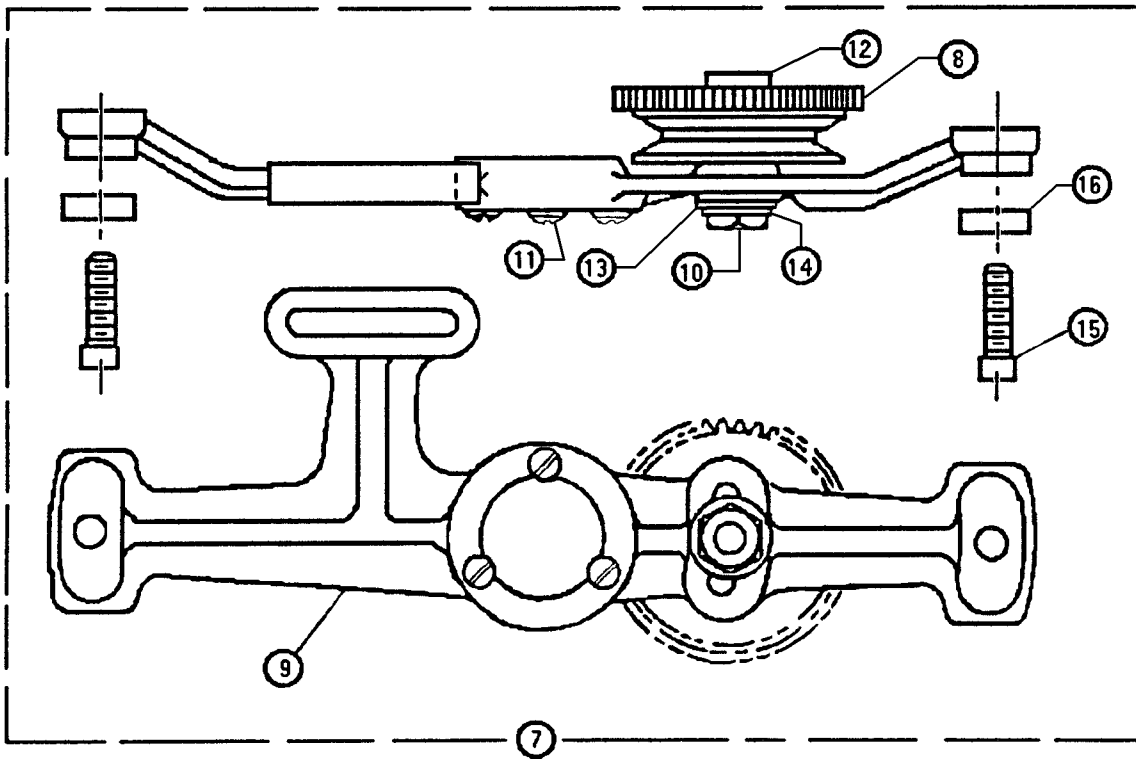
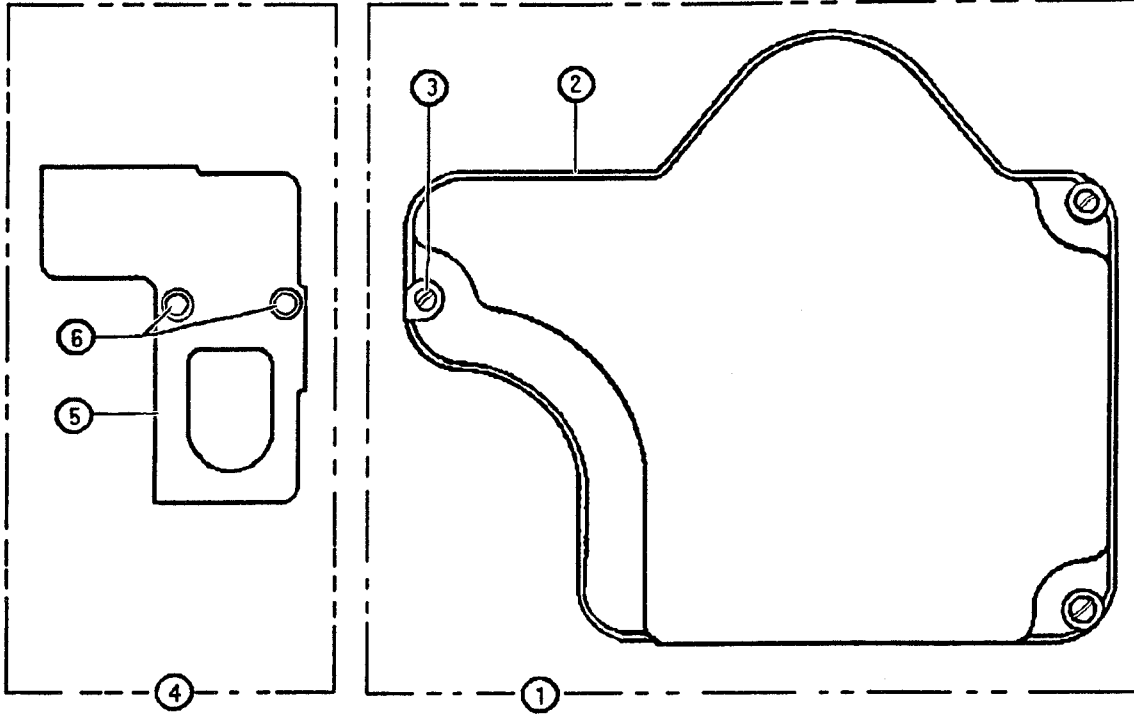

DRIVE SIDE COVER ASSEMBLY (82-60056)

<u>Item</u>	<u>Part No.</u>	<u>Description</u>
1	R3-130	Drive Side Cover Assembly
2	CR-0074	Cover Casting
3	SC-0572	Shoulder Screw, 1/4-20 x 7/8" (3 req'd.)

TERMINAL PANEL COVER ASSEMBLY (82-60187)

<u>Item</u>	<u>Part No.</u>	<u>Description</u>
4	R3-300	Terminal Panel Cover Assembly
5	CR-0801	Cover Casting
6	SC-0521	Thumb Screw

ADJUSTING ARM ASSEMBLY (82-60206), Direct Drive

<u>Item</u>	<u>Part No.</u>	<u>Description</u>
7	R50-90B	Adjusting Arm Assembly
8	R3-91*	Gear, Take-Up Pulley
9	AR-0178	Arm Casting
10	NU-0038*	Stud Nut, 5/16-18
11	41-51061	Bearing Retaining Screw, 8-32 x 1/4" (3 req'd.)
12	SU-2134*	Pulley Stud
13	41-70005*	Washer, 5/16"
14	WA-0258*	Lockwasher, 5/16"

*Associated Parts*

15	01544000	Mounting Screw, 1/4-20 x 7/8" (2 req'd.)
16	SA-1724	Spacer (2 req'd.)

\* *Optional* Reel Take-Up Components

See Page 21 for Adjusting Arm Assembly, Standard Drive

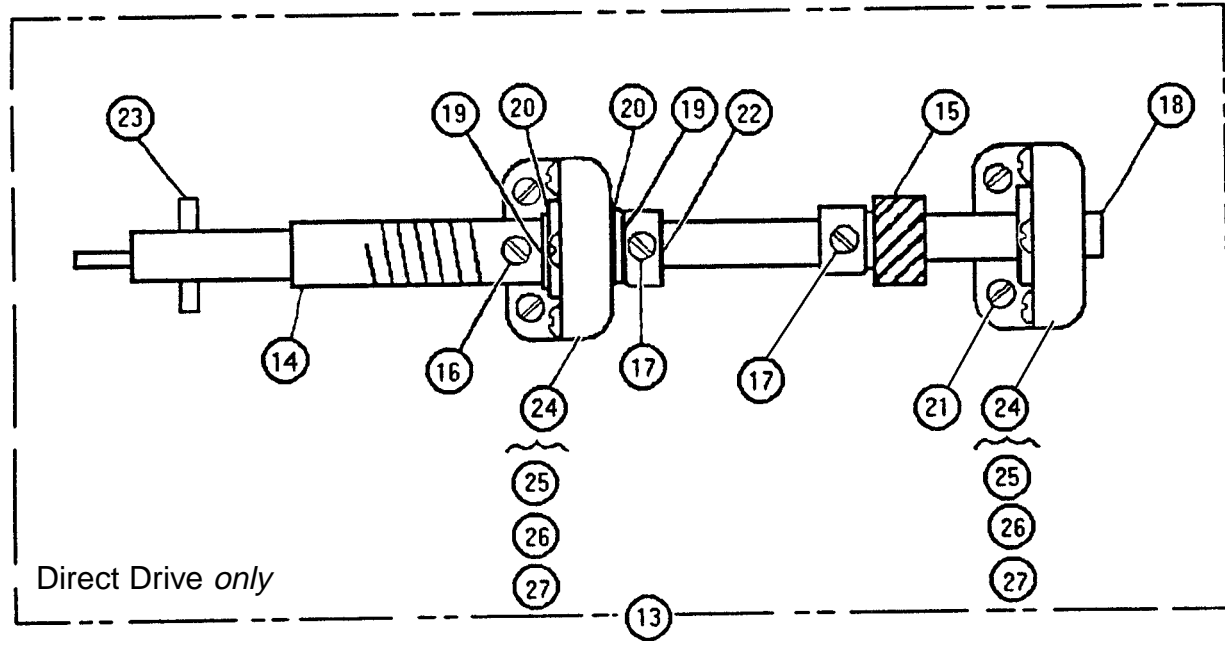
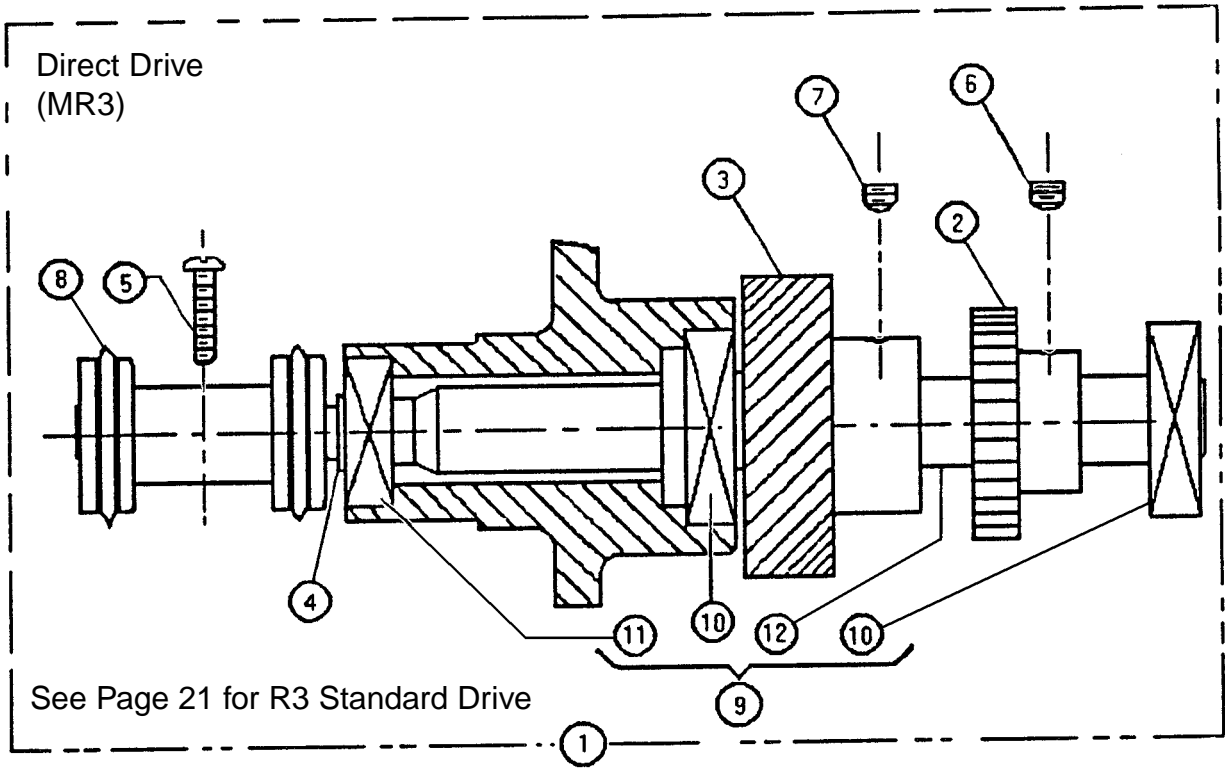

### HORIZONTAL DRIVE SHAFT ASSEMBLY (82-60148), Direct Drive

<u>Item</u>	<u>Part No.</u>	<u>Description</u>
1	R50-70A	Sprocket Shaft Assembly
	R50-72	Drive Shaft & Ball Bearings Assembly
2	GR-0068*	Spur Gear
3	GR-0254	Helical Gear
4	RI-0092	Retaining Ring
5	41-51043	Sprocket Screw, 6-32 x 1/2" Fillister Head
6	SC-0585*	Spur Gear Set Screw, 10-32 x 3/16"
7	SC-0982	Helical Gear Set Screw, 10-32 x 1/4" (2 req'd.)
8	SK-2204	Film Sprocket, 35mm
	* <i>Optional</i> Reel Take-Up Components	

### MAIN DRIVE SHAFT WITH BALL BEARINGS ASSEMBLY (R50-72)

<u>Item</u>	<u>Part No.</u>	<u>Description</u>
9	R50-72	Shaft with Ball Bearings Assembly
10	BG-0726A*	Ball Bearing (2 req'd.), Main
11	BG-0204A*	Ball Bearing, Operating Side
12	ST-1787*	Horizontal Shaft
	* Order R50-72	

### VERTICAL DRIVE SHAFT ASSEMBLY (82-60141), Direct Drive

<u>Item</u>	<u>Part No.</u>	<u>Description</u>
13	R50-370A	Vertical Drive Shaft Assembly
	R50-371*	Bearings & Bracket Assembly (2 req'd.)
14	R50-373	Flexible Shaft & Coupling
15	GR-0133	Helical Gear
16	SC-0003	Fastening Screw, 8-32 x 11/16" Fillister Head
17	00255000	Fastening Screw, 8-32 x 5/16" Fillister Head (2 req'd.)
18	ST-1976	Drive Shaft
19	WA-0003	Thrust Washer, Fibre (2 req'd.)
20	WA-0010	Thrust Washer, Steel (2 req'd.)
21	41-51369	Mounting Screw, 1/4-20 x 5/8" Fillister Head (4 req'd.)
22	CL-0013	Thrust Collar
23	RI-0612	Grease Seal Ring

### VERTICAL SHAFT BALL BEARING & BRACKET ASSEMBLY (R50-371\*)

<u>Item</u>	<u>Part No.</u>	<u>Description</u>
24	R50-371*	Ball Bearing & Bracket Assembly (2 req'd.)
25	BG-0009	Ball Bearing
26	BR-0020	Bearing Bracket
27	41-51061	Bearing Retaining Screw, 8-32 x 1/4" Bind Head

\* Not sold as Assembly - Order Individual Components



## DRIVE MOTOR SUPPORT COMPONENTS

Item	Part No.	Description
28	BR-0921	Motor Support Casting
29	PE-0137	Rubber Shim
30	SC-1860	Mounting Screw (4 req'd.)
31	WA-0068	Steel Washer
32	WA-0069	Rubber Washer

See Page 28 for Drive Motors

## IDLER ROLLER ASSEMBLY (82-60143)

Item	Part No.	Description
34	R5-80	Idler Roller Assembly
35	2933	Snap Ring
36	SU-2179	Stud
37	R5-36	Roller & Bearings
38	BG-1199A*	Ball Bearing (2 req'd.)
39	RO-0551*	Film Roller

\* Order R5-36

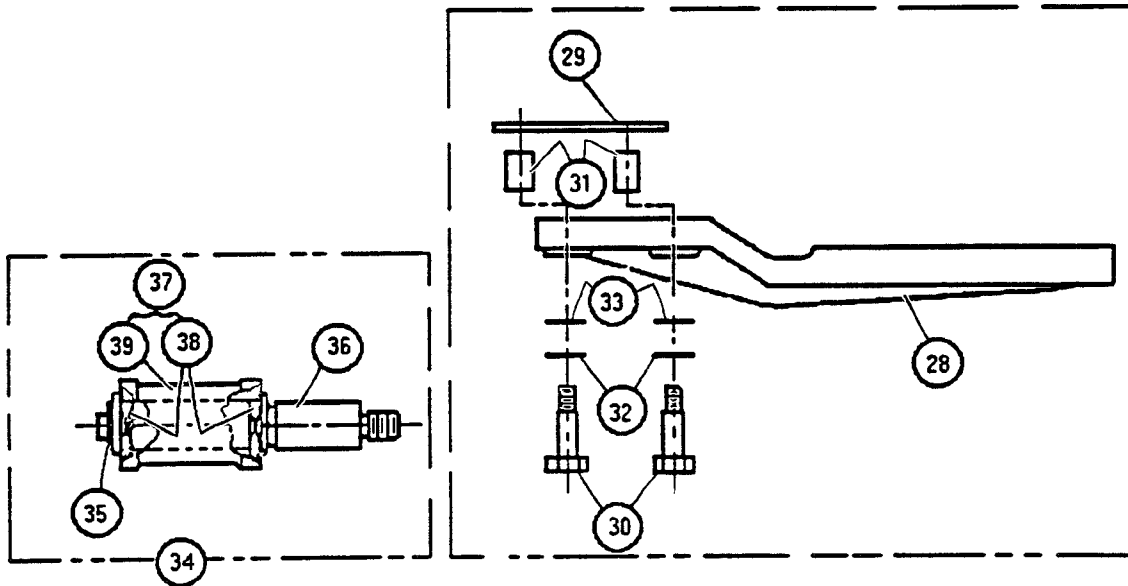

70mm Bypass

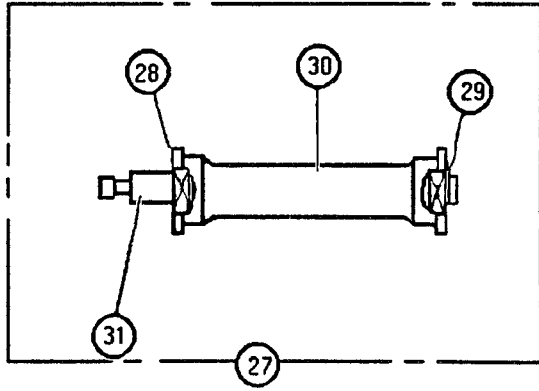
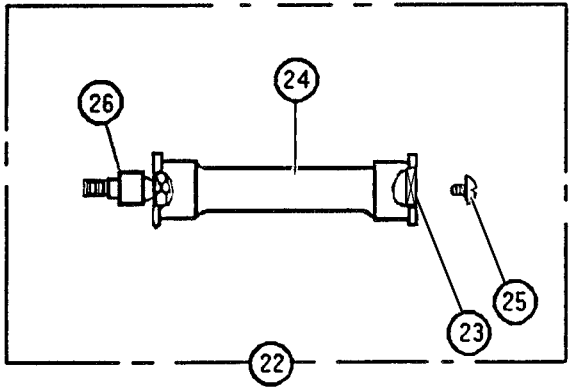
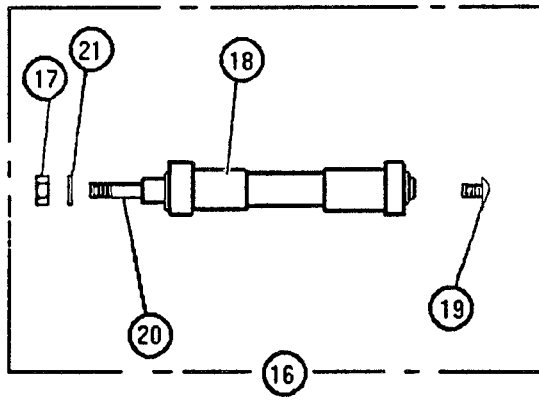
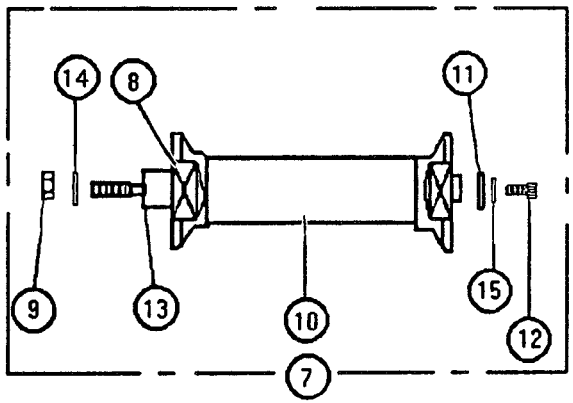
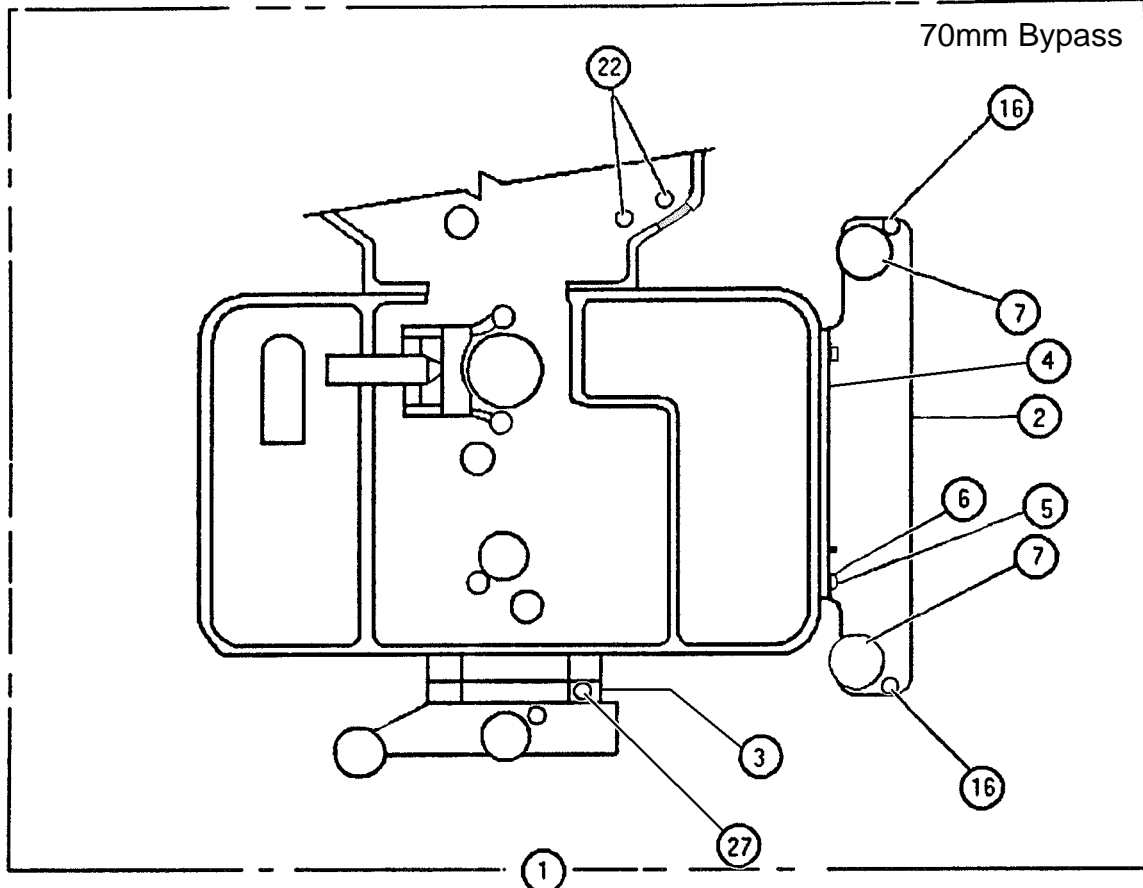

SOUNDHEAD FILM BYPASS KIT (R50-500), JR3-E 70mm Application

<u>Item</u>	<u>Part No.</u>	<u>Description</u>
1	R50-500	Film Bypass Kit
	R50-505	Transfer Roller (2 req'd.)
	R50-510	Stabilizer Roller (2 req'd.)
	R50-515	Projector Exit Roller (2 req'd.)
	R50-520	Failsafe Guide Roller
2	BR-1320	Roller Mounting Bracket
3		Failsafe Entrance Roller Bracket
4	3053	Bracket Adjusting Set Screw, 1/4-20 x 3/8" (4 req'd.)
5	3069	Mounting Screw, 1/4-20 x 5/8" Socket Head (2 req'd.)
6	WA-0070	Washer

TRANSFER ROLLER ASSEMBLY, 70mm (82-60066)

<u>Item</u>	<u>Part No.</u>	<u>Description</u>
7	R50-505	Transfer Roller Assembly
8	BG-0133	Ball Bearing (2 req'd.)
9	NU-0038	Spindle Nut, 5/16-18
10	RO-0614A	Film Roller, 70mm
11	SA-1724	Spacer
12	SC-1572	Screw, 1/4-20 x 3/8" Socket Head
13	SD-2421	Spindle
14	WA-0227	Washer
15	WA-0302	Lockwasher

STABILIZER ROLLER ASSEMBLY, 70mm (82-60144)

<u>Item</u>	<u>Part No.</u>	<u>Description</u>
16	R50-510	Stabilizer Roller Assembly
17	NU-0007	Stud Fastener Nut
18	RO-0207	Stabilizer Roller, 70mm
19	41-51065	Screw, 8-32 x 5/16" Bind Head
20	SU-2422	Stud
21	WA-0302	Lockwasher

PROJECTOR EXIT ROLLER ASSEMBLY (R50-515\*), 70mm

<u>Item</u>	<u>Part No.</u>	<u>Description</u>
22	R50-515*	Projector Exit Roller Assembly
23	BG-1260A	Ball Bearing (2 req'd.)
24	RO-0204	Film Guide Roller, 70mm
25	SC-1233	Screw, 8-32 x .2650"
26	SU-1478	Roller Stud

\* Not sold as Assembly - Order Individual Components

FAILSAFE GUIDE ROLLER ASSEMBLY (82-60145), 70mm

<u>Item</u>	<u>Part No.</u>	<u>Description</u>
27	R50-520	Failsafe Guide Roller Assembly
28	BG-1260A	Ball Bearing (2 req'd.)
29	2933	Snap Ring
30	RO-0204	Film Guide Roller, 70mm
31	SU-2285	Roller Stud

SHAFT & PULLEYS

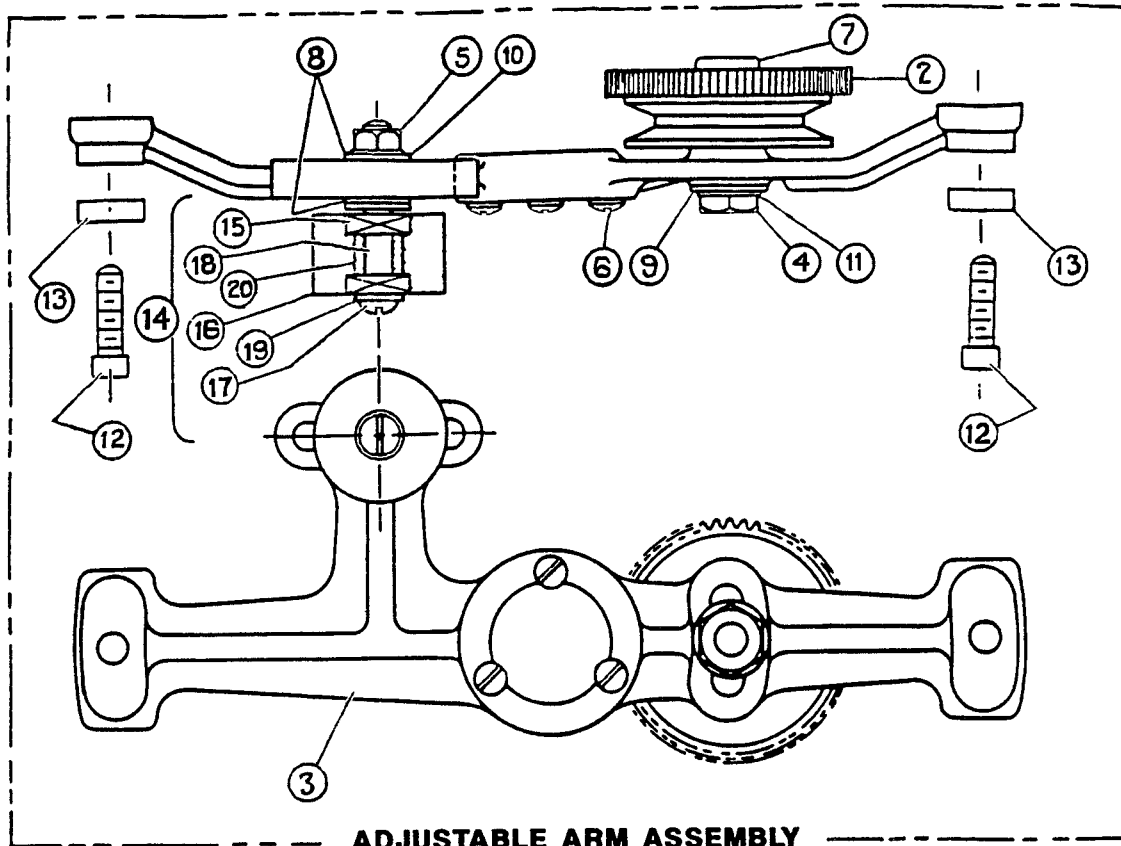
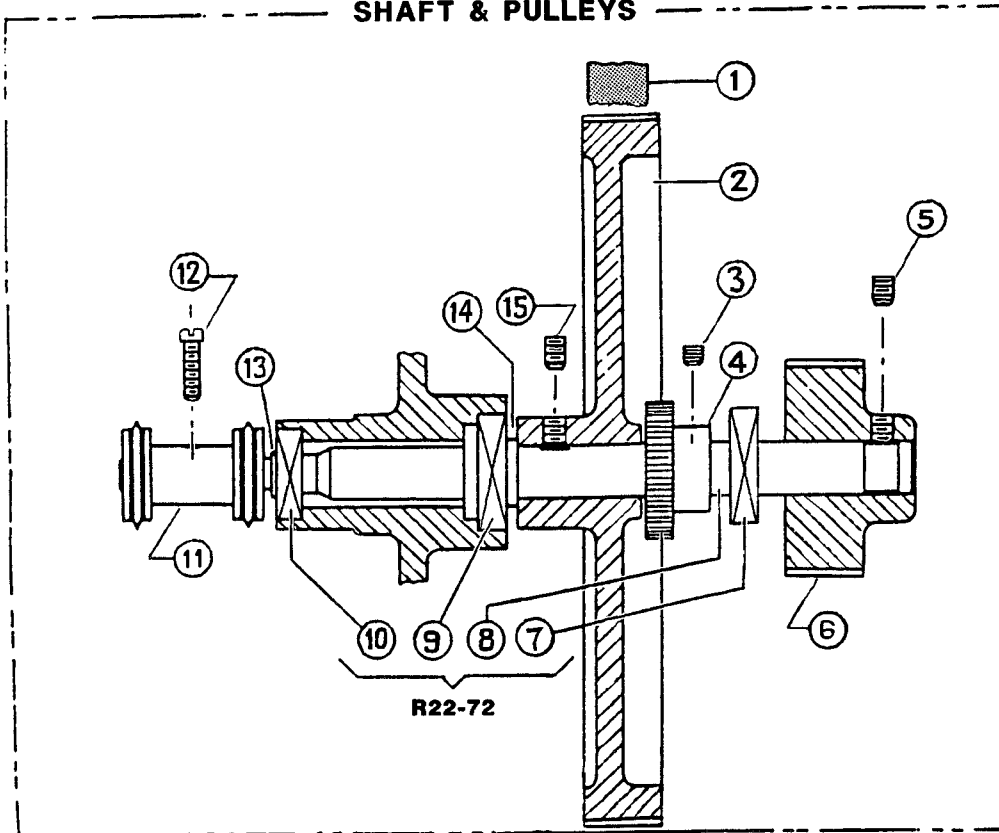

ADJUSTABLE ARM ASSEMBLY

STANDARD DRIVE (R3)

## STANDARD DRIVE (R3)

### SHAFT & PULLEYS

Item	Part No.	Description
1	BE-0548	Drive Belt, Motor
2	PY-1081 *	Soundhead Driven Pulley
3	SC-0585	Set Screw, 1/4-20 x 3/16"
4	GR-0068	Gear, Take-Up Pulley Drive
5	41-51180	Set Screw, 1/4-20 x 3/8"
6	PY-0573	Projector Drive Pulley
-	BE-0529	Drive Belt, Projector
-	PY-1303	Projector Driven Pulley (BE-0529 & PY-1303 shown below)
7	BG-0726	Ball Bearing
8	ST-1696	Sprocket Shaft
9	BG-0726	Ball Bearing
10	BG-0204	Ball Bearing
-	R22-72	Shaft & Bearing Ass'y. (Items 7-10)
11	SK-2454	Film Sprocket, 35mm
12	41-51038	Screw, 6-32 x 1/2" Fil. Head
13	RI-0092	External Snap Ring
14	SA-1697	Spacer
15	41-51180	Set Screw, 1/4-20 x 3/8"

\* Domestic (USA) 60 Hz. Models;  
See Page 23 for Options.

### ADJUSTABLE ARM ASSEMBLY

Item	Part No.	Description
1	R50-90	(Order by Component)
2	R3-91	Take-Up Pulley Gear
3	AR-0178	Adjustable Arm Casting
4	NU-0038	Nut, 5/16-18
5	NU-0306	Nut, Idler Roller Stud
6	41-51061	Screw, 8-32 x 1/4"
7	SU-2134	Stud, Take-Up Pulley
8	WA-0077	Steel Washer
9	41-70004	Steel Washer
10	41-70023	Steel Washer
11	WA-0258	Lockwasher, 5/16"
12	41-51123	Screw, 1/4-20 x 7/8"
13	P-7002	Steel Washer
14	R3-94	Drive Pulley & Gear
15	BG-0204	Ball Bearing
16	RO-0570	Idler Roller
17	SC-0536	Screw, 10-32 x 1/4"
18	SU-0556	Idler Retaining Stud
19	WA-0070	Washer, #10

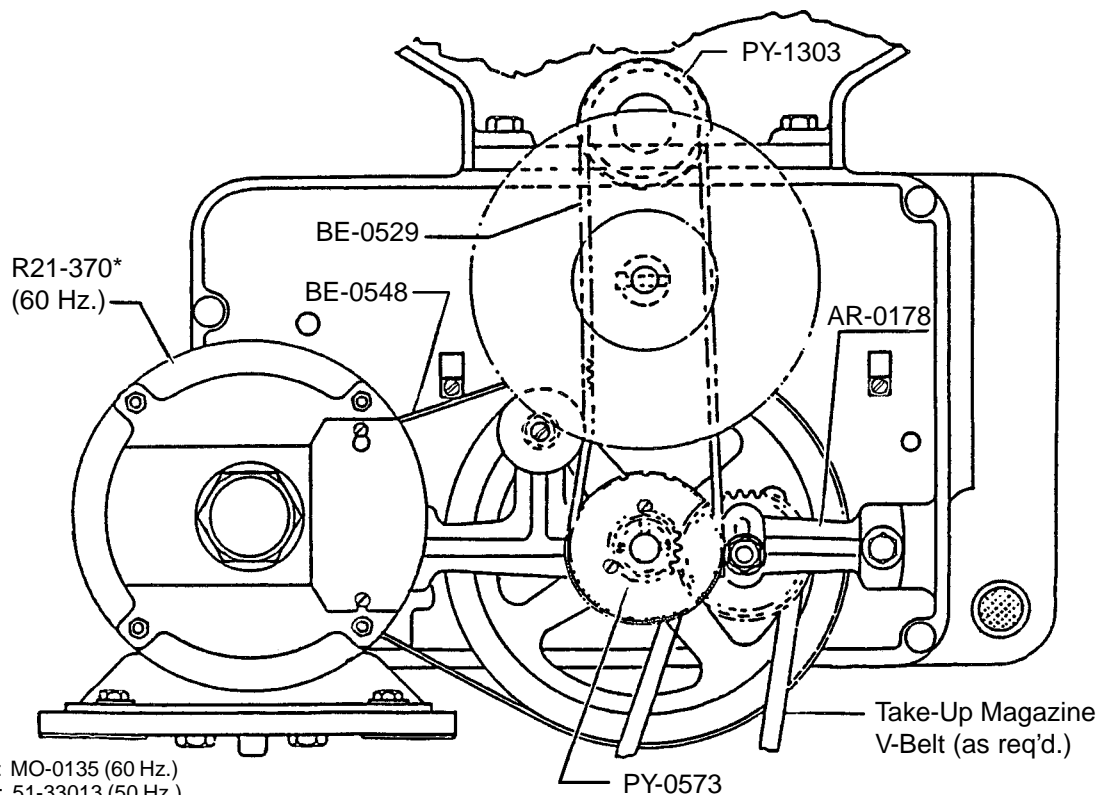

\*Motor: MO-0135 (60 Hz.)  
Motor: 51-33013 (50 Hz.)  
Flywheel: WH-0251  
Pulley: R3-75

**KELMAR ATD-1274 READER ASSEMBLY (optional)**

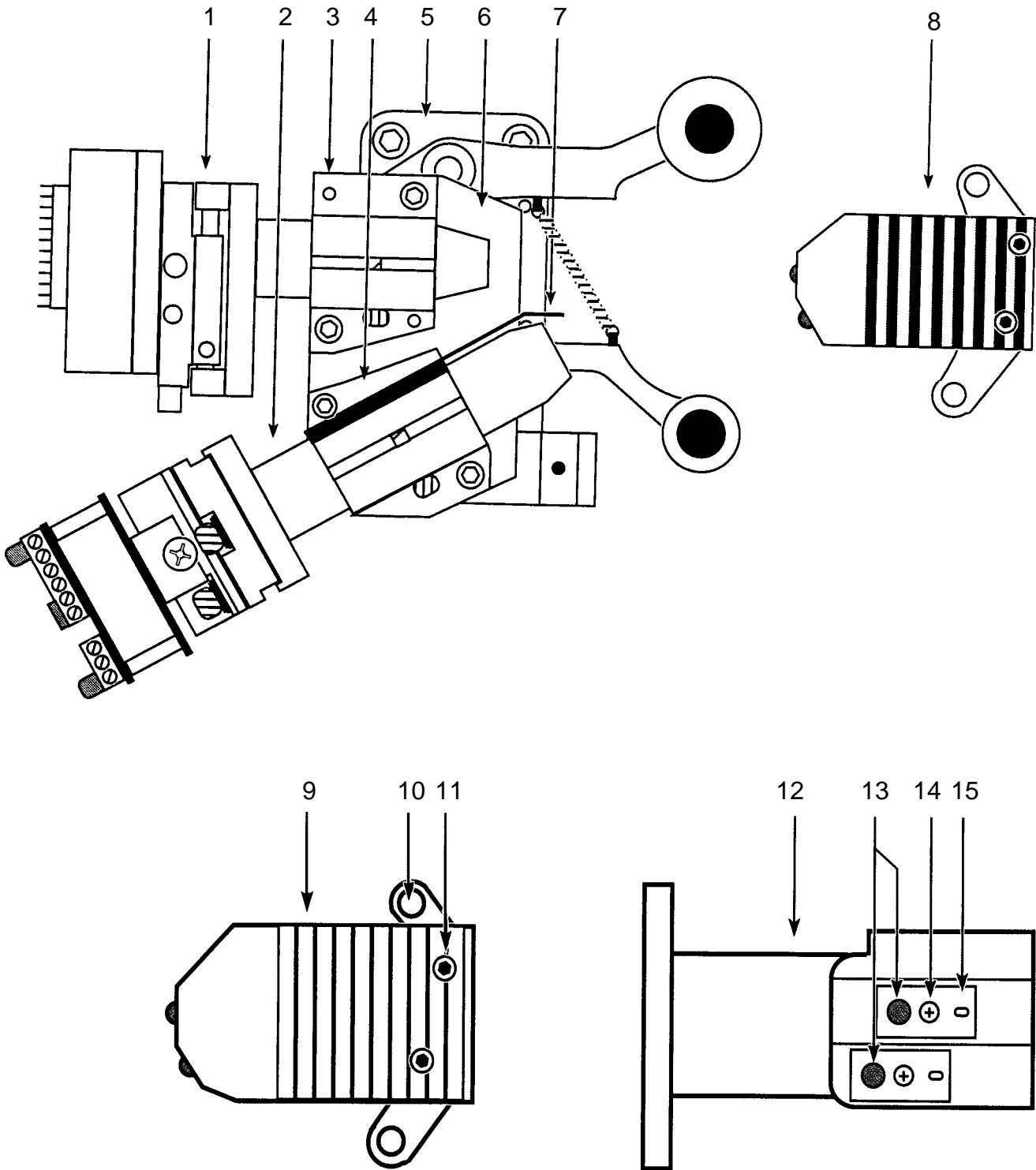

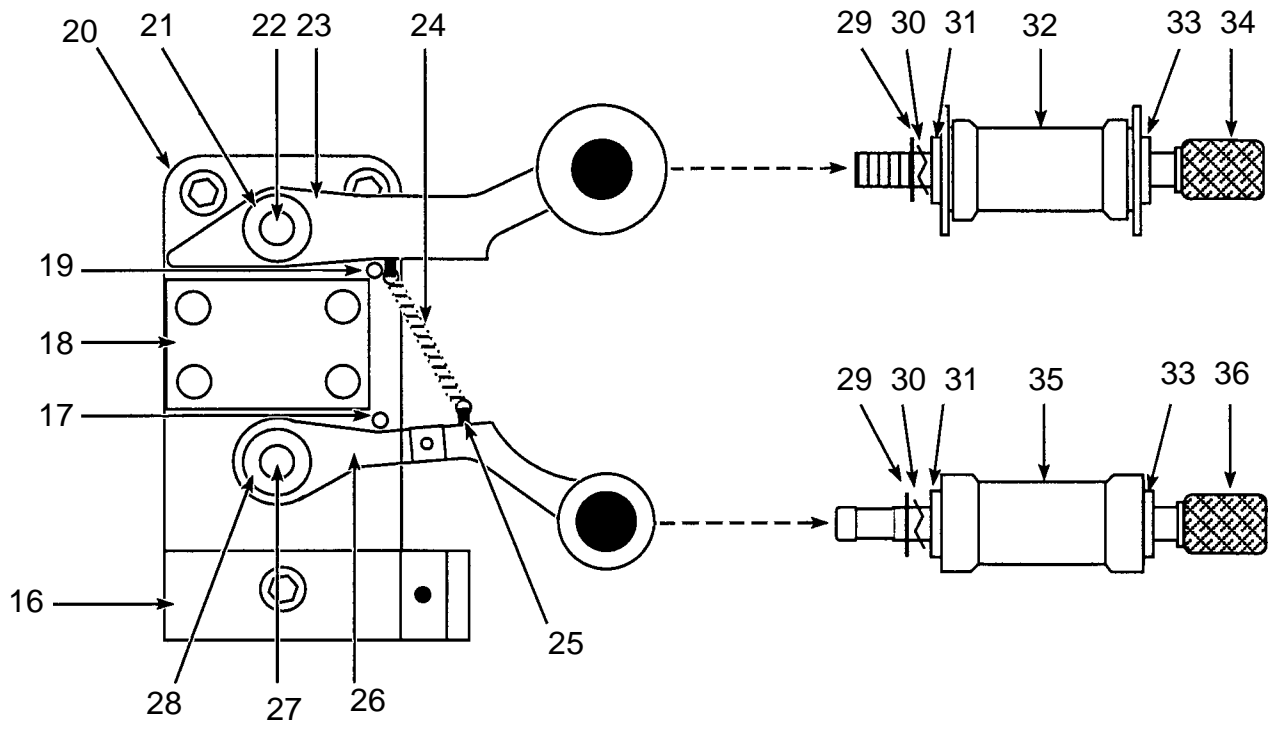

<u>Item</u>	<u>Part No.</u>	<u>Description</u>	<u>Item</u>	<u>Part No.</u>	<u>Description</u>
1	54-68110	Digital Reader Assembly	19	54-68082	Arm Stop Pin
2	54-68116	Analog Reader Assembly	20	54-68085	Main Base Plate
3	54-68112	Digital Reader Clamp Block	21	54-68086	Bearing
4	54-68117	Analog Reader Clamp Block	22	54-68087	Dancer Arm Post
5	54-68078	Dancer Arm & Base Ass'y.	23	54-68088	Upper Arm
6	54-68113	Reader Mounting Plate	24	54-68089	Damper Spring
7	54-68114	Light Shield	25	54-68093	Adjusting Stud
8	54-68080	Dual L.E.D. Assembly	26	54-68092	Lower Arm
9	54-68074	Arm	27	54-68087	Dancer Arm Post
10	54-68075	Base	28	54-68086	Bearing
11	54-68076	Screw, 4-40 x 3/4"	29	54-68094	Snap Ring, 1/4"
12	54-68077	Post	30	54-68095	Spring Washer
13	54-68122	L.E.D.	31	54-68096	Bearing
14	54-68123	Clamp Screw	32	54-68097	Guide Roller
15	54-68124	L.E.D. Clamp	33	54-68096	Bearing
16	54-68081	Dashpot Mounting Bracket	34	54-68098	Shaft Assembly
17	54-68082	Arm Stop Pin	35	54-68099	Damper Roller
18	54-68083	Base Plate	36	54-68100	Shaft Assembly



**KELMAR READERS (optional)**

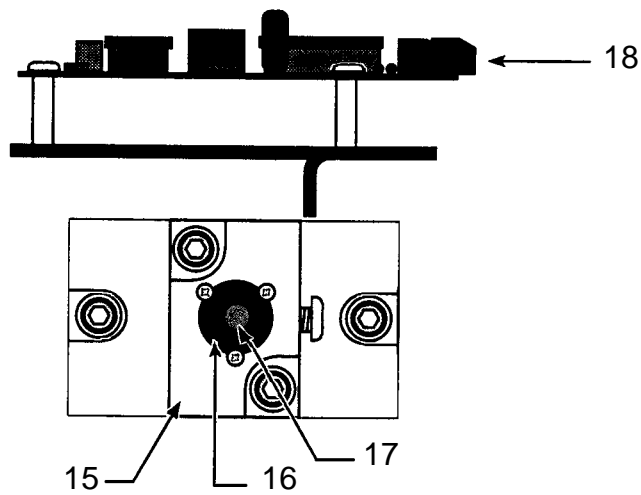
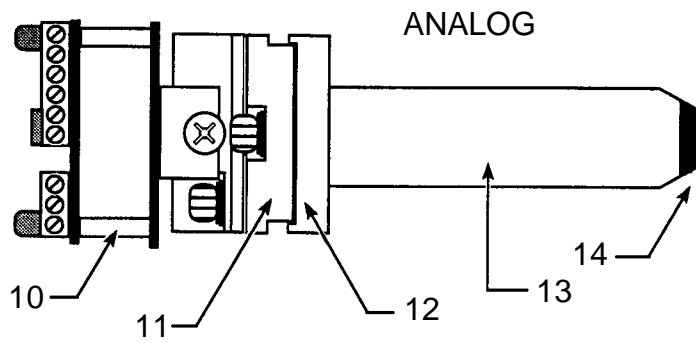
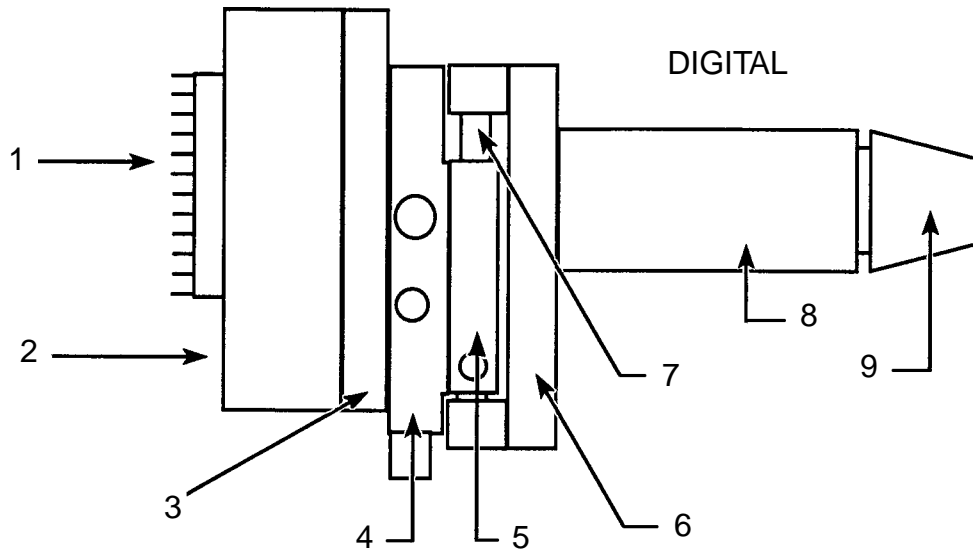

#### DIGITAL READER (ATD-1300)

<u>Item</u>	<u>Part No.</u>	<u>Description</u>
1	54-68101	CCD Reader Board
2	54-68102	Cover, CCD Reader Board
3	54-68103	Base Plate, CCD Reader
4	54-68104	Vertical Plate
5	54-68105	Horizontal Plate
6	54-68106	Base Plate
7	54-68107	Horizontal Shaft Runner Shaft
8	54-68108	Lens Tube
9	54-68109	Lens & Carrier

#### ANALOG READER (AT-1250)

<u>Item</u>	<u>Part No.</u>	<u>Description</u>
10	54-68125	Mounting Plate, Pre-Amp Board
11	54-68126	Horizontal Slide
12	54-68127	Main Base Plate
13	54-68128	Lens Tube
14	54-68129	Lens
15	54-68130	Vertical Slide
16	54-68131	Solar Cell Retainer
17	54-68132	Solar Cell, with Mask
18	54-68133	Solar Cell Pre-Amp

**CENTURY DRIVE PULLEYS, .375" Pitch**

<u>Part No.</u>	<u>Bore (inches)</u>	<u>Tooth Count</u>
PY-0573	.500	22
PY-0575	.500	59
PY-0576	.825	12
PY-0577	.500	14
PY-0578	.438	36
PY-1072	.625	21
PY-1081	.500	50
PY-1303	.625	17
R3-75	.625	10
R3-76	.625	12
10024	.500	56

**R3-E (Standard) DRIVE PULLEYS**

<u>Motor rpm</u>	<u>Motor Pulley</u>	<u>Motor Belt</u>	<u>Soundhead Pulley</u>	<u>Projector Belt</u>
1800	R3-75	BE-0548	PY-1081	BE-0529
1750	R3-76	BE-0528	PY-0575	BE-0529
1500	R3-76	BE-0548	PY-1081	BE-0529
1450	PY-0577	BE-0528	10024	BE-0529

### CENTURY DRIVE MOTORS

MO-0116	115/230 V.AC, 50 Hz. 1 ph.	1400 rpm
MO-0119	230 V.AC, 50/60 Hz. 3 ph. Sync	1800 rpm
MO-0121	230 V.AC, 50 Hz. 1 ph.	1725 rpm
MO-0126	208 V.AC, 60 Hz. 3 ph. Sync	1200 rpm
MO-0127	230 V.AC, 60 Hz. 3 ph. Sync	1200 rpm
MO-0128	380 V.AC, 50 Hz. 3 ph. Sync	1000 rpm
MO-0129	415 V.AC, 50 Hz. 3 ph. Sync	1500 rpm
MO-0132	115/230 V.AC, 60 Hz. 1 ph.	1725 rpm
MO-0135	115 V.AC, 60 Hz. 1 ph. Sync	1800 rpm
MO-0135 Kit (with Mounting Plate):	Order 82-60017	
51-33013	230 V.AC, 50/60 Hz. 3 ph. Sync	1800 rpm