

Film-Tech

The information contained in this Adobe Acrobat pdf file is provided at your own risk and good judgment.

These manuals are designed to facilitate the exchange of information related to cinema projection and film handling, with no warranties nor obligations from the authors, for qualified field service engineers.

If you are not a qualified technician, please make no adjustments to anything you may read about in these Adobe manual downloads

www.film-tech.com

OPERATING INSTRUCTIONS

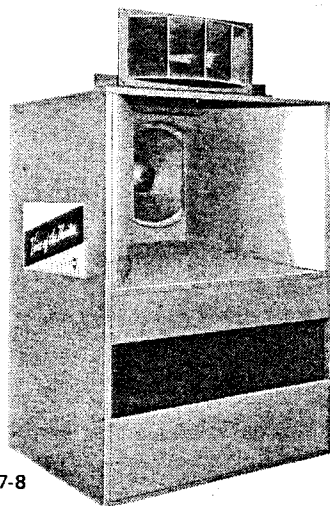

A7-8

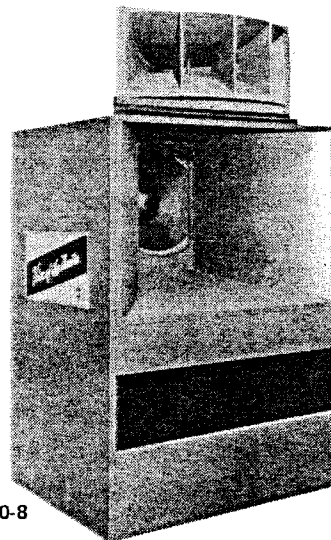

A7-500-8

SPECIFICATIONS

A7-8

A7-500-8

<p>SPEAKER COMPONENTS — LOW FREQUENCY: HIGH FREQUENCY:</p> <p>NOMINAL IMPEDANCE:</p> <p>CROSSOVER FREQUENCY:</p> <p>ENCLOSURE TYPE:</p> <p>SENSITIVITY: Measured at 4 feet, 1 watt input referenced to 8 ohms, using pink noise which has been limited to a bandwidth of 500 Hz to 3 kHz</p> <p>FREQUENCY RESPONSE:</p> <p>DISPERSION: Measured with pink noise limited to a bandwidth of 500 Hz to 8 kHz</p> <p>LONG TERM BROAD BAND MAXIMUM POWER: Measured with a source of pink noise limited to the frequency response bandwidth of the system, over an extended time period</p> <p>OPERATIONAL POWER RANGE: Recommended for use with amplifiers between these levels</p> <p>LONG TERM MAXIMUM ACOUSTIC OUTPUT: Measured with a source of pink noise limited to the frequency response bandwidth of the system at a distance of 4 feet</p> <p>FINISH:</p> <p>DIMENSIONS:</p> <p>SHIPPING WEIGHT:</p> <p>ACTUAL WEIGHT:</p>	<p>15" bass driver (416-8B) 806-8 type compression driver mounted to 811B sectoral horn</p> <p>8 ohms</p> <p>800 Hz (N801-8A network)</p> <p>Horn loaded with reflex port</p> <p>101 dB SPL</p>	<p>15" bass driver (416-8B) 802-8 type compression driver mounted to 511B sectoral horn</p> <p>8 ohms</p> <p>500 Hz (N501-8A network)</p> <p>Horn loaded with reflex port</p> <p>101 dB SPL</p>
	<p>45 Hz to 20 kHz</p> <p>60° at -6 dB vertical 90° at -6 dB horizontal</p> <p>50 watts</p> <p>10 watts to 250 watts</p> <p>118 dB SPL at 50 watts</p> <p>Theatre gray</p> <p>52 1/4" H x 30" W x 24" D 132.7 cm H x 76.2 cm W x 61.0 cm D</p> <p>160 lbs — 72.6 kg 135 lbs — 61.2 kg</p>	<p>45 Hz to 20 kHz</p> <p>60° at -6 dB vertical 90° at -6 dB horizontal</p> <p>50 watts</p> <p>10 watts to 250 watts</p> <p>118 dB SPL at 50 watts</p> <p>Theatre gray</p> <p>54 1/4" H x 30" W x 24" D 137.8 cm H x 76.2 cm W x 61.0 cm D</p> <p>163 lbs — 73.9 kg 142 lbs — 64.4 kg</p>

Specifications and components subject to change without notice. Overall performance will be maintained or improved.

1515 S. Manchester Ave., Anaheim, Calif. 92803

42-02-042116-03
 LITHO IN U.S.A. 379-1M

KIT COMPONENTS FOR ALTEC A7-8 AND A7-500-8 SYSTEMS

QTY.	DESCRIPTION
1	416-8B Bass Driver
7	• 1/4"-20 x 1 1/4" machine screws
1	806-8 type HF Driver (A7-8 system only)
1	802-8 type HF Driver (A7-500-8 system only)
2	• 1/4"-20 hex nuts
10	• 1/4" I.D. lockwashers
1	811B Horn (A7-8 system only)
1	511B Horn (A7-500-8 system only)
1	• Horn mounting board
4	•• No. 10 x 1 1/2" round-head sheet metal screws
1	• 30411 Horn Mounting Bracket
1	•• 10 x 3/4" round-head wood screw
1	1/4"-20 x 3/4" machine screw
1	NB01-8A 800 Hz Network (A7-8 system only)
1	N501-8A 500 Hz Network (A7-500-8 system only)
4	• 8-32 x 1" oval-head machine screws
1	828B Enclosure
1	• Rear panel
16	•• No. 8 x 1 1/4" flat-head wood screws

EXTERNALLY MOUNTED HF HORN

- Place 828B LF Horn Cabinet face down. Loosen wood screws securing rear access panel to cabinet and remove panel.
- Install 416-8B LF Speaker using four 1/4"-20 x 1 1/4" machine screws and lockwashers at T-nut mountings (see Figure 1).

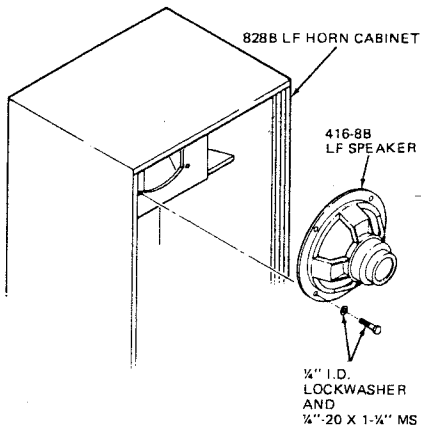

Figure 1. LF Speaker Installation

- Rear access panel has dual cover panel (see Figure 2). Smaller panel covers hole for mounting network; larger panel covers hole for mounting biampfier. Remove network hole cover and store for later potential use. Retain four 8-32 x 1" oval-head machine screws used to secure cover.
- Install network in rear access panel with four screws retained from Step 3 (see Figure 3).

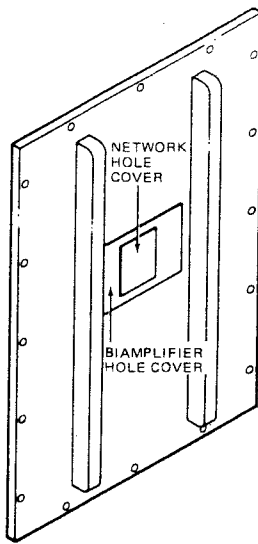

Figure 2. Rear Panel with Covers

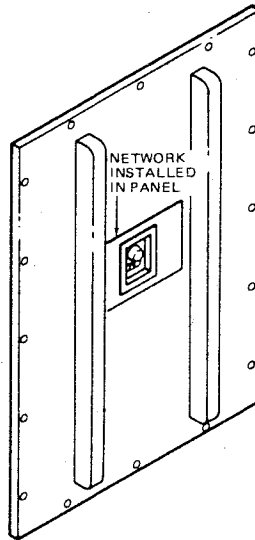

Figure 3. Rear Panel with Network Installed

- Place 828B cabinet upright. Remove horn mounting board from inside bottom of cabinet. If assembling an A7-8 system (811B horn, 806 type driver), scribe a line 4 inches from front edge of cabinet, center horn mounting board on scribed line, and secure with four No. 10 x 1 1/2" round-head sheet metal screws at predrilled holes (see Figure 4a). If assembling an A7-500-8 system (511B horn, 802 type driver), center horn mounting board on front edge of cabinet and secure with four No. 10 x 1 1/2" round-head sheet metal screws at predrilled holes (see Figure 4b).
- Assemble HF driver and 30411 Horn Mounting Bracket to flange of sec-

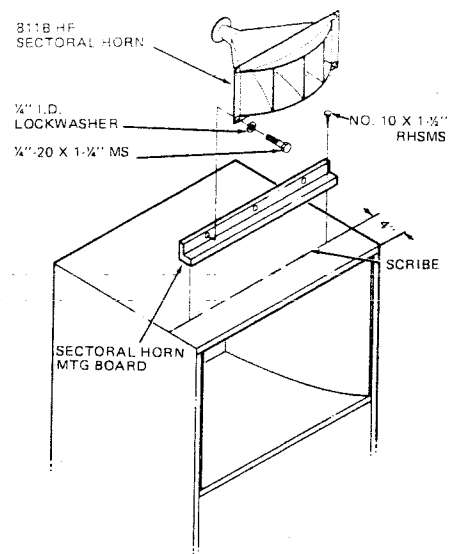

Figure 4a. External Mounting of Sectoral Horn (A7-8)

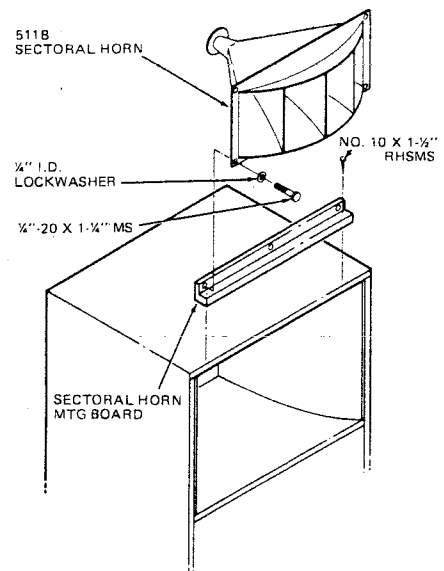

Figure 4b. External Mounting of Sectoral Horn (A7-500-8)

toral horn as shown, using two 1/4"-20 hex nuts and lockwashers. Make sure horn mounting gasket is not damaged. Assemble two parts of 30411 Horn Mounting Bracket together, using 1/4"-20 x 3/4" machine screw, lockwasher, and nut as shown in Figure 5. Do not tighten.

- Install assembled HF horn to mounting board with three 1/4"-20 x 1 1/4" machine screws and lockwashers at three aligned T-nut mountings in board (see Figure 4). Do not tighten screws until horn position is set. Figure 6 shows horn installed.
- Install 30411 bracket on 828B cabinet with a No. 10 x 3/4" round-head wood screw (see Figure 5).

9. Set desired angle of HF horn by adjusting bracket. Tighten machine screw while holding bracket. Tighten three mounting screws at front of HF horn.

10. Using wire leads supplied with network, interconnect components as shown in Figure 7. Leads to HF driver may be taken through 1/2" diameter wire hole in rear panel (see Figure 8).

NOTE

Prepared wire leads contain push-on spade clips for connecting to lugs on network. Opposite ends of wire leads are tinned for insertion in binding post terminals of LF speaker and HF driver.

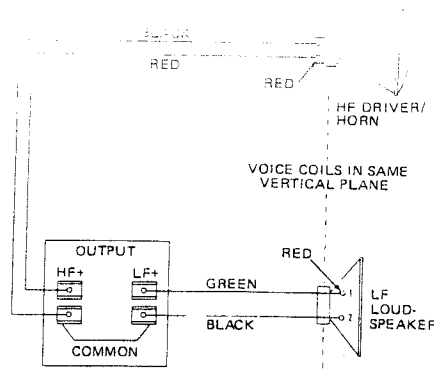

Figure 7. System Interconnect Diagram

flat-head wood screws from front panel, remove front grille brace. Store brace with grille. Rear panel may be completely removed to provide more working room, if necessary.

Follow the same procedure outlined for external horn mounting (Step 5), except reverse HF horn mounting for internal position as shown in Figures 9 and 10. When installing sectoral horn mounting board (Steps 5, 7 and 8), remove only enough fiberglass insulation from cabinet wall to permit mounting directly to wood surface. When installation is complete, install front panel (if removed) on cabinet as shown in Figure 10.

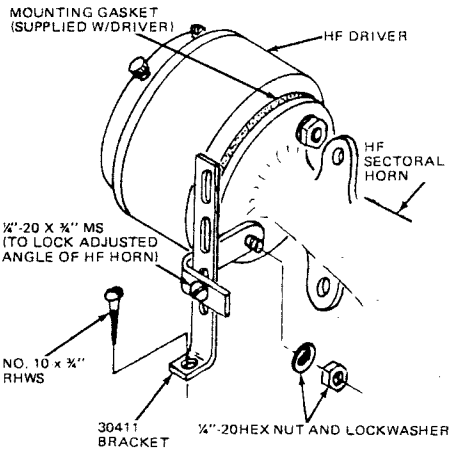

Figure 5. HF Driver and Horn Assembly

11. Replace rear panel and secure to cabinet with sixteen No. 8 x 1 1/4" flat-head wood screws. Figure 8 shows panel (with network) installed.

12. Connect the output of amplifier to appropriate terminals of network.

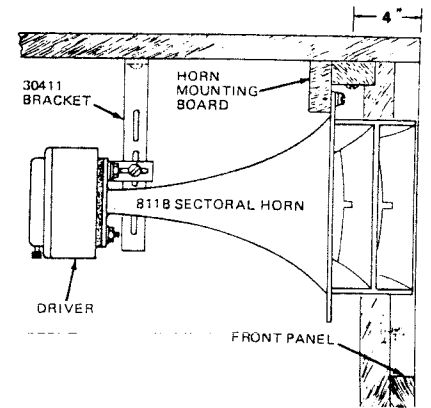

Figure 9. Internal Mounting of HF Horn Unit (A7-8)

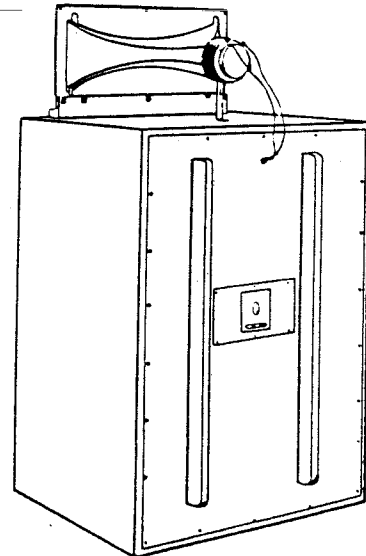

Figure 8. Externally Mounted HF Horn System, Rear View

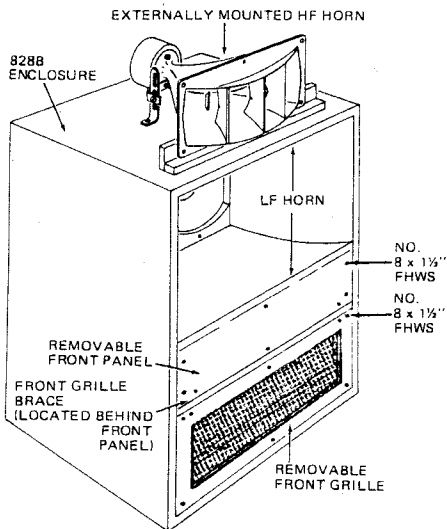

Figure 6. Externally Mounted HF Horn System, Front View (A7-8)

INTERNALLY MOUNTED HF HORN

To mount HF horn inside 828B cabinet, remove seven No. 8 x 1 1/4" flat-head wood screws from front grille (see Figure 6). Remove grille and store for possible future use. Remove three No. 8 x 1 1/4"

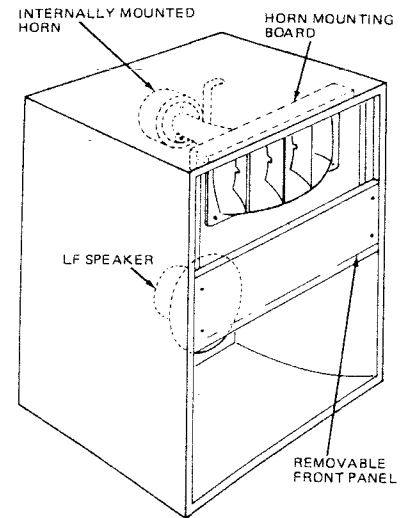

Figure 10. Internally Mounted HF Horn System

*Attenuator/Equalizer
30904
Network*

INTRODUCTION

ALTEC component loudspeakers are the same loudspeakers that, in their studio enclosures, are the standard of the professional recording, broadcast and theatre industries. ALTEC loudspeakers are hand-crafted and tested to meet ALTEC's standards — the most rigid in the industry.

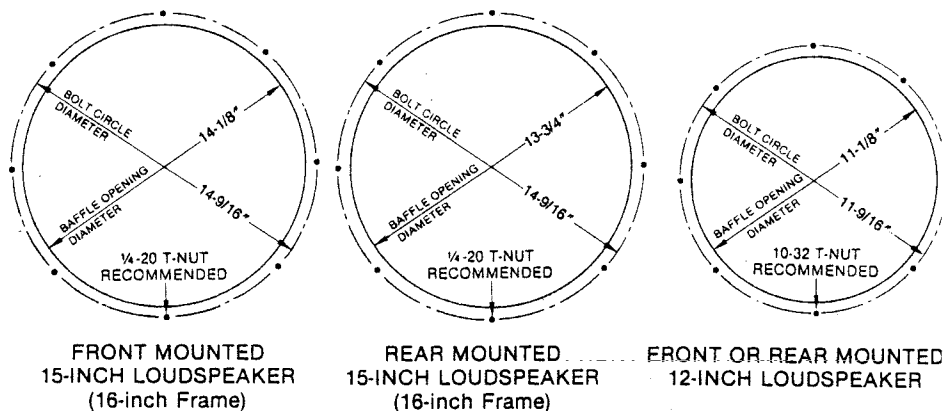

Figure 1. Mounting Parameters for 12-inch and 16-inch Loudspeakers

INSTALLATION

Protect the Loudspeakers

To protect the cone assembly, all loudspeakers should be kept face down on a clean surface until installed. The aluminum centerdomes in certain extended range speakers are particularly fragile and should not be touched.

Enclosures

The prime reason for an enclosure or baffle is to separate the sound radiated from the rear of a low frequency loudspeaker diaphragm or cone so that it does not cancel the radiation generated by the front of the cone. The enclosure is designed as a component of an acoustical system. A properly designed cabinet cannot make a poorly designed loudspeaker operate satisfactorily, nor can a well designed loudspeaker perform efficiently when housed in an inferior enclosure.

Mounting Dimensions

Figure 1 shows dimensions necessary to mount ALTEC loudspeakers used with applicable crossover networks. Figure 2 shows the mounting dimensions for networks.

Mounting Network

Networks are installed with T-nuts and bolts to a surface having a cutout of dimensions shown in Figure 2. Use the template given at the end of these instructions to facilitate installation. Fix the template to the surface where the network is to be mounted. Use a

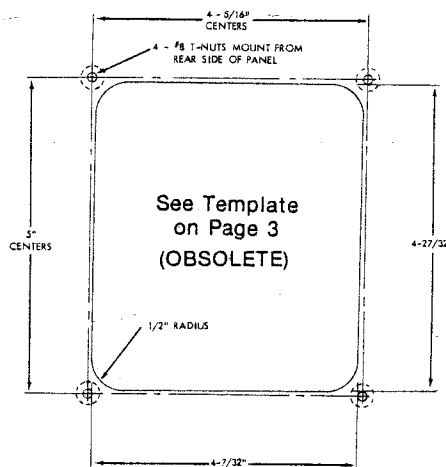

Figure 2A. Cutout Dimensions for N501-8A, N801-8A and N809-8A Networks

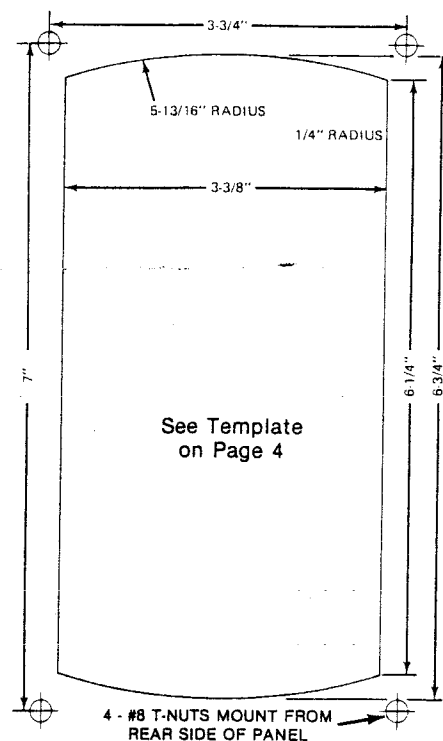

Figure 2B. Cutout Dimensions for N501-8B, 1201-8A and 1209-8A Networks

7/32" (0.218) drill to bore four holes to accept shafts of 8-32 T-nuts. A recommended method to make the cutout is to cut slightly undersize and use a wood rasp or file to finish the edges to exact size. Remove all debris from the holes, from the cut edges, and from within the enclosure. Insert four T-nuts in mounting holes from inner side of enclosure and gently hammer each in place until T-nut faces are flush with enclosure surface. Insert the network in the cutout and secure with four 8-32 bolts.

Mounting Low Frequency Loudspeakers

Low frequency loudspeakers are installed with T-nuts and bolts to a baffle having a cutout and mounting bolt pattern appropriate for the loudspeaker (see Figure 1). Several models of loudspeakers may be front or rear mounted as shown in Figures 3 and 4. For loudspeakers weighing more than 10 pounds, a baffle of 3/4-inch plywood free from voids is recommended. To install the loudspeakers, use the following procedure:

1. Locate and scribe circles for the speaker hole and the mounting bolts according to the particular speaker (see Figure 1). Cut out smaller (speaker hole) circle; a suggested method is to make the cut very slightly undersize and use a wood rasp or file to finish edge to exact size.

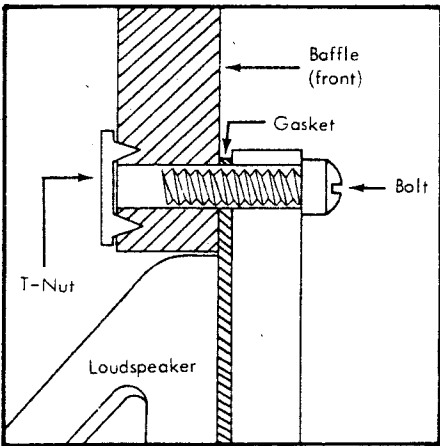

Figure 3. Front Mounted Loudspeaker

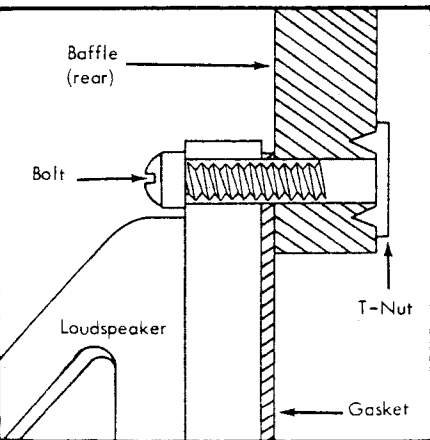

Figure 4. Rear Mounted Loudspeaker

2. Set loudspeaker over smaller hole so mounting bolt circle is centered in loudspeaker mounting holes. Carefully mark location of each bolt hole and remove loudspeaker. Loudspeakers with 8 bolt holes would be mounted using any 4 alternate holes.
3. Use an appropriate drill to bore holes to accept shafts of appropriate size T-nuts (see Table I).

Table I. Drill Sizes for T-Nuts

T-nut Size	Drill Size
1/4"-20	5/16" (0.312)
10-32	15/64" (0.234)
8-32	7/32" (0.218)

4. Remove all debris from holes, edges and enclosures.
5. Insert all T-nuts in mounting holes according to front or rear loudspeaker mounting option (see Figures 3 and 4). Gently hammer each T-nut in place until T-nut faces are flush with baffle surface.
6. Install the loudspeaker (per Figure 3 or 4) in the mounting hole. Secure the loudspeaker to all T-nuts with appropriate sized bolts.

CAUTION

DO NOT overtighten mounting bolts. Tighten bolts just enough so no air leaks around loudspeaker flange. Do not tighten bolts with such force that loudspeaker frame is forced out of alignment. Tighten bolts evenly, a little at a time, moving around circle as many times as necessary.

WIRING

Wire Size

Ordinary commercial 18-gauge, stranded, insulated wire may be used for connection of ALTEC loudspeakers and dividing networks. This is considered minimum size wire for speaker/amplifier connections up to 30 feet. For wire runs longer than 30 feet, 16-gauge or larger wire is recommended.

Wire Connections

When two or more loudspeakers are connected to a common output, total impedance of the combination should be considered relative to the amplifier's output.

Solid state amplifiers are marked with two terminals (+ and -). Any speaker load may be hooked to these two terminals. The power of the amplifier will vary, based on the impedance load of the speakers. It is recommended that no speaker load of less than 4 ohms total impedance be used.

Tube type amplifiers and some solid state amplifiers are transformer coupled to specified impedances of 4, 8 or 16 ohms. In such instances the speaker load should match the corresponding terminal of the amplifier.

Single speaker connections (Figure 5A) are equal to the rated speaker impedance.

For speakers in series connections (Figure 5B), total speaker impedance is the sum of the individually rated speaker impedance.

For speakers connected in parallel (Figure 5C), total speaker impedance is equal to that of a single speaker, divided by the number of speakers connected (when all speakers have the same rated impedance).

For speakers connected in series-parallel (Figure 5D), total speaker impedance is equal to that of a single speaker (when all speakers have the same rated impedance).

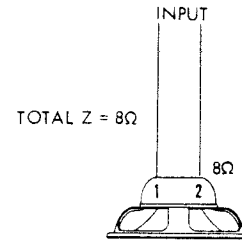

Figure 5A. Single-Speaker Connections

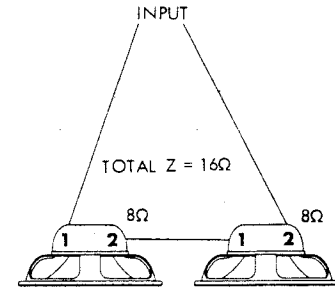

Figure 5B. Series Connection

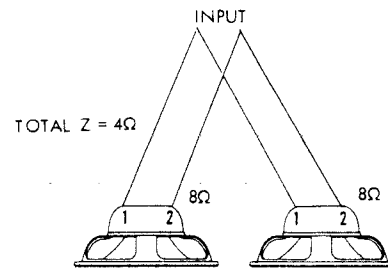

Figure 5C. Parallel Connection

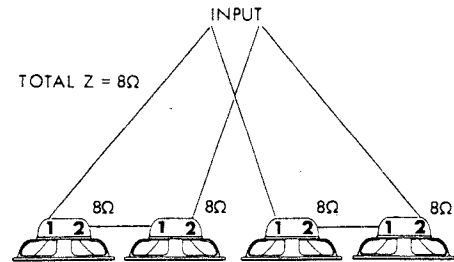

Figure 5D. Series-Parallel Connection

Figure 5. Typical Speaker Wire Connections

Multiple low frequency speakers should equal the impedance of the low frequency dividing network output. Multiple system impedance is treated similarly.

until the best possible position and polarity (best sound quality and frequency response) is determined. Equalization can be used to smooth *minor* irregularities of

response. It should be remembered that excessive equalization can cause significant phase shift, decreased headroom and increased noise levels.

POLARITY

The two-way (HF horn and LF woofer) loudspeaker system must be properly polarized to obtain a smooth response in the cross-over region. This refers to the polarity relationship between the horn-loaded HF driver and the LF loudspeaker. To achieve proper polarity, the electrical polarity between the HF horn-loaded driver and the LF loudspeaker may require adjustment.

ALTEC electrical polarity convention establishes that a positive voltage applied to the red (+ or L1) terminal causes positive sound pressure in front of the loudspeaker or horn. Depending upon physical placement of the two-way system components, correct electrical polarity may require a positive signal to be applied to the red (+ or L1) terminal of each component ("in-phase" connection), or that wiring of one component be reversed ("out-of-phase" connection).

Whenever possible, align the speaker/driver coils in the same plane. Operate the system with music or other test signals (such as pink noise), with the speaker/driver coils electrically connected in-phase (same electrical polarity). See Figure 6. Perform the tests in a room with as few reflections (echoes or reverberation) as possible. Alternately, do the testing outdoors away from buildings and out of earshot of any loud traffic or industrial noise. Use a real-time analyzer, other test equipment or your ears to determine sound quality and frequency response of the system.

If the sound system does not have acceptable quality, reverse polarity of the high frequency driver (out-of-phase connection). Also try shifting the speaker or driver forward or backward with respect to the previous in-plane orientation. Keep re-positioning the speaker or driver, while alternating the polarity of the high frequency driver,

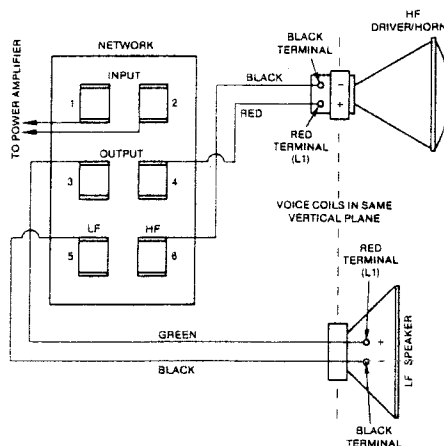
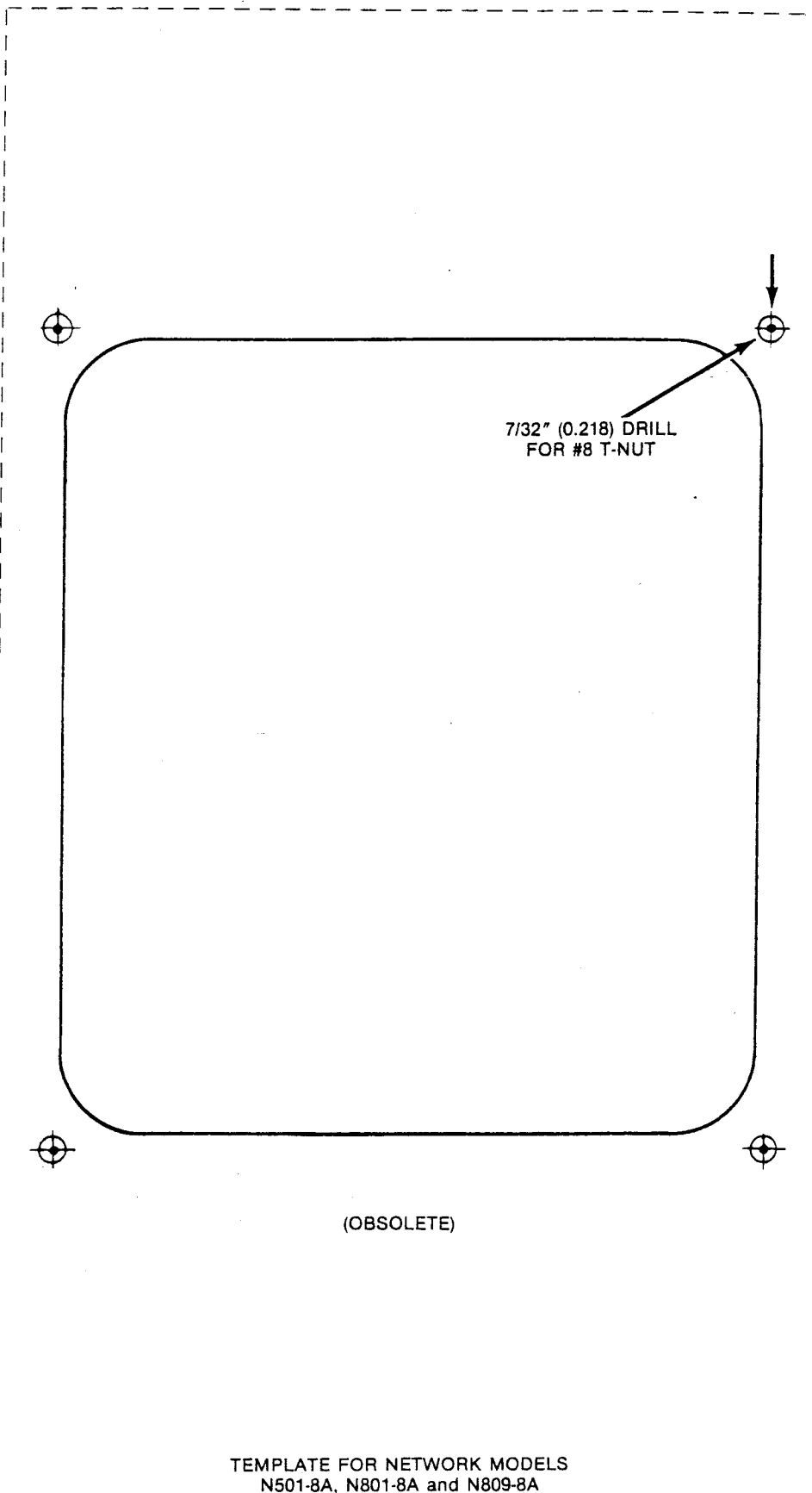

Figure 6. Voice Coil In-Plane Connections



TEMPLATE FOR NETWORK MODELS
N501-8A, N801-8A and N809-8A

STEREO "PHASING"

Proper system acoustic "phasing" of the left and right loudspeaker units in a home stereo music system is essential. Many elaborate methods for determining correct phase are available. This can be done easily in the home by making a simple test.

Listen to the system in the monophonic mode, or with a mono sound source. The sound should emanate directly from between the speaker systems. If any stereo effect is still heard, reverse the polarity of one system; this should restore the apparent sound source to the single desired point. When the sound appears to be at this mid-point in the mono mode, it will have the correct acoustic phasing for stereo.

HIGH AND MID FREQUENCY ATTENUATION

In two-way systems, it is advantageous for the listener to be able to adjust the volume level of the high and mid frequencies with reference to the LF loudspeaker. ALTEC passive dividing networks are designed to provide sound level adjustments in two-way loudspeaker systems while maintaining a flat response throughout the bandwidth.

The networks are specially engineered with two equalization controls which attenuate mid and high frequencies.

By varying the equalization controls, the user is able to modify the characteristics of the system response to match a wide variety of acoustic environments. The mid-frequency adjustment, in addition to the traditional high-frequency control, adds three-way versatility to a two-way speaker system.



Figure 7. Typical Network

LOUDSPEAKER POWER CAPACITY

The power capacity of ALTEC high fidelity loudspeakers is rated with reference to integrated program material. Isolated transients can be handled up to several times the indicated power capacity. Steady state sine wave signals should be held to not more than 10% of specified power level capacities.

CAUTION

Never connect the loudspeaker to 120 volt, 50/60 Hz line power (house current). This will damage the loudspeaker.

IF YOU ARE HAVING TROUBLE

Your ALTEC loudspeaker is a precision instrument, responding with high accuracy to the variations in electric current produced by other components in your system. Extraneous noise such as hum, rumble, or hissing do not originate in the loudspeaker. If you experience difficulty in realizing the fine performance built into your ALTEC loudspeaker, the dealer from whom you purchased your components will be happy to supply expert advice and help, or you may write directly to:

Consumer Correspondence
ALTEC
1515 South Manchester Avenue
Anaheim, California 92803

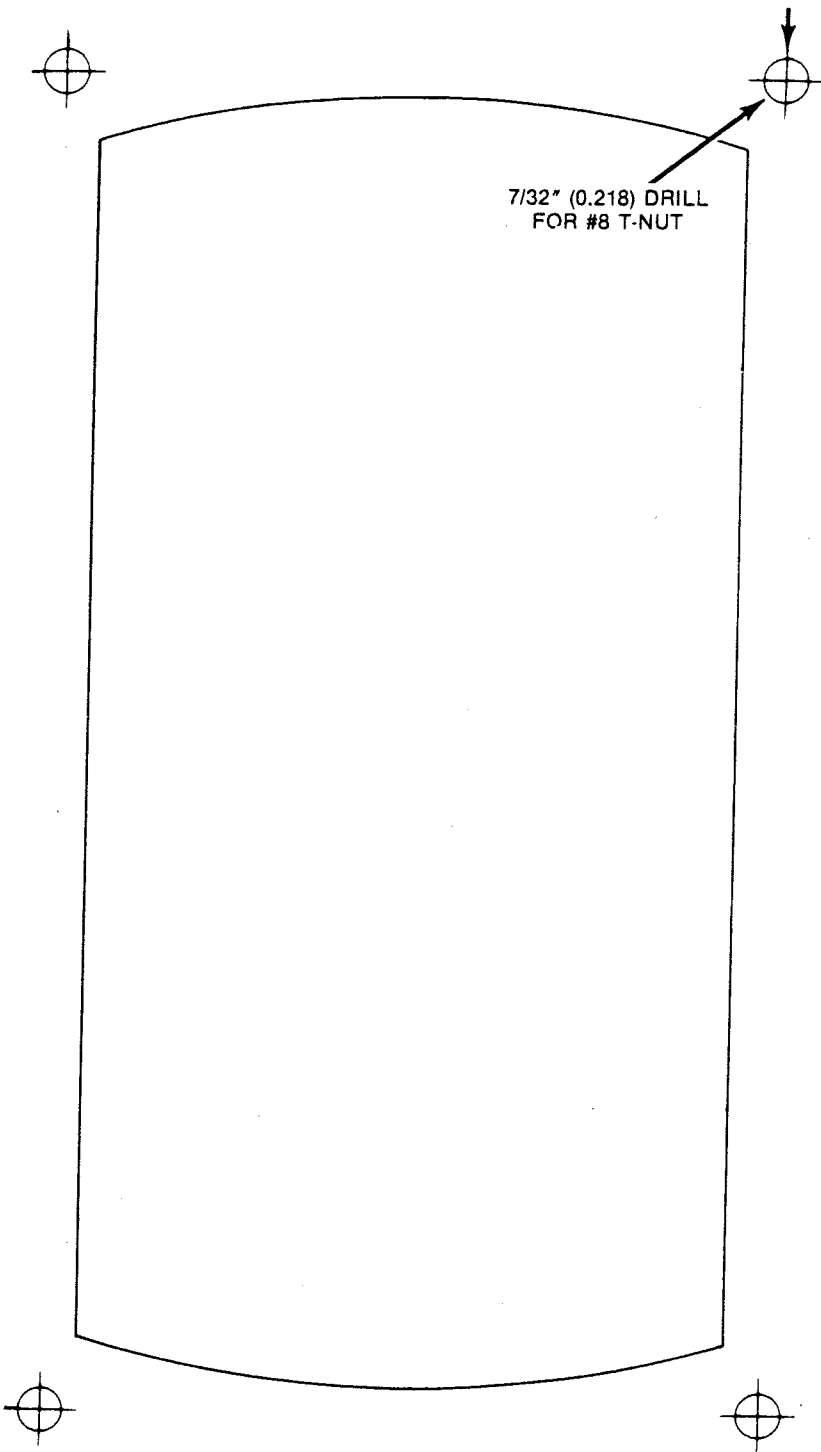

TEMPLATE FOR NETWORK MODELS
N1201-8A and N1209-8A