

# Film-Tech

The information contained in this Adobe Acrobat pdf file is provided at your own risk and good judgment.

These manuals are designed to facilitate the exchange of information related to cinema projection and film handling, with no warranties nor obligations from the authors, for qualified field service engineers.

If you are not a qualified technician, please make no adjustments to anything you may read about in these Adobe manual downloads.

[www.film-tech.com](http://www.film-tech.com)

# Alpha 70mm Crossover Kit Installation & Operation

PRODUCT INFORMATION BULLETIN #4326  
SUPPLEMENT TO ALPHA OPERATION MANUAL #2989

The 70mm Crossover Kit allows a 35mm Alpha Platter System to be used for either 35mm or 70mm film. Only the pulleys, spools and other parts required for 70mm operation require changing. Many of the 35mm components remain in place. This conversion requires the addition of seven drilled and tapped holes. If your column has not been drilled for the 70mm pulleys, see Product Information Bulletin #4324 for drilling instructions. A drill bit, tap and a drilling guide are included in kit #4329..

## INSTALLATION PROCEDURE

1. Replace the 35mm Castor Swivel and Bracket at the top of the column with the new 70mm Bracket and Castor Swivel Assembly, Right. (See item 1, page 2).

**NOTE:** The Bracket and Castor Swivel Assembly, Right is similar to the Bottom Castor Bracket and Castor Swivel Assembly, Left installed in step 7 (Page 2). The Bottom Castor Bracket is "L" shaped while the top bracket is straight.

2. Install new 70mm Column Shaft & Pulley Assemblies (1552), new Column Pulley Shafts (1655) and Spool Assemblies (1491) in the new holes in the column as shown in Fig. 1, (page 2).

3. Replace the 35mm pulleys and bracket on the top of the control side of the column with a new Bracket (1168) and Column Shaft and Pulley Assemblies (1552) as shown in Fig. 2 (page 2).

4. Remove the three 35mm Column Castor Mount Assemblies from the column and replace with three 70mm Column Castor Mount Assemblies (4317). (See Fig. 2, page 2).

5. Disconnect electrical power and remove the cover on the variac. Remove the nut securing the power supply linkage rod to the variac link. (See Fig. 3, page 2).

6. Remove the 35mm Take-Up Assembly and transfer the power supply linkage rod to the new 70mm Take-Up Assembly (2880). Install the 70mm Take-Up Assembly by first inserting the power supply linkage rod into the case and then mounting the Take-Up to the column. Connect the power supply linkage rod to the variac link. Check the micro switch adjustment and reinstall the cover.

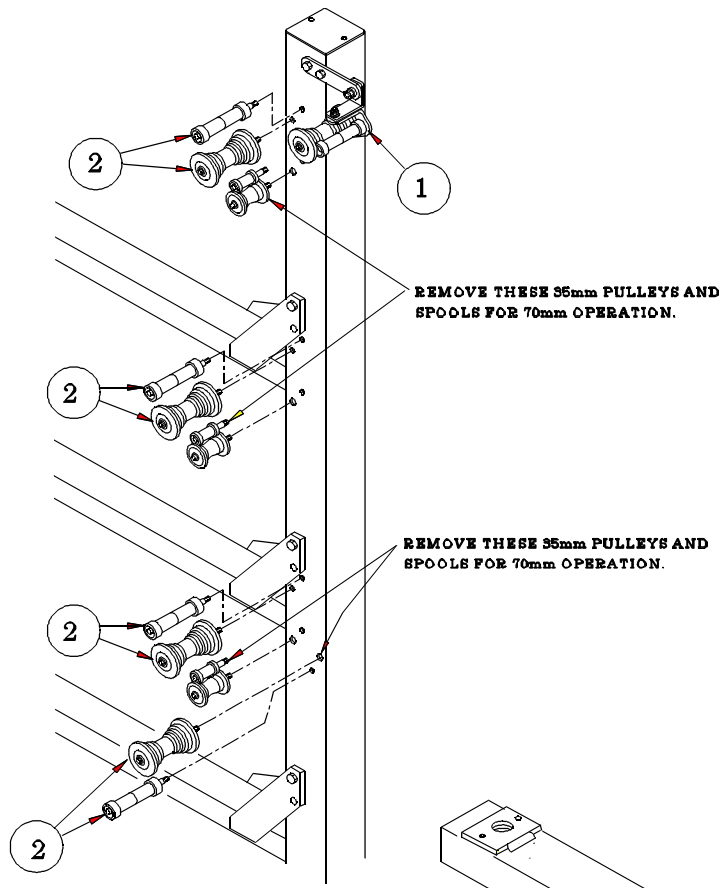

**FIGURE 1**

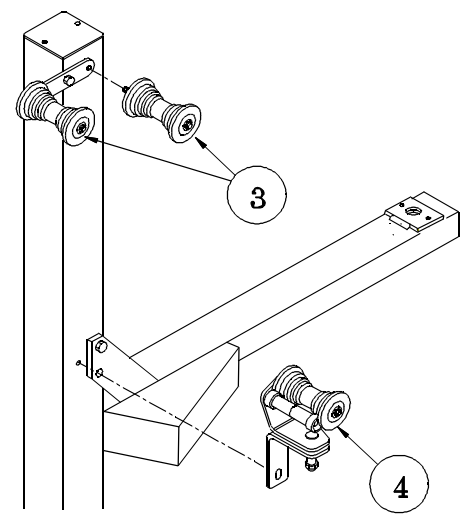

**FIGURE 2**

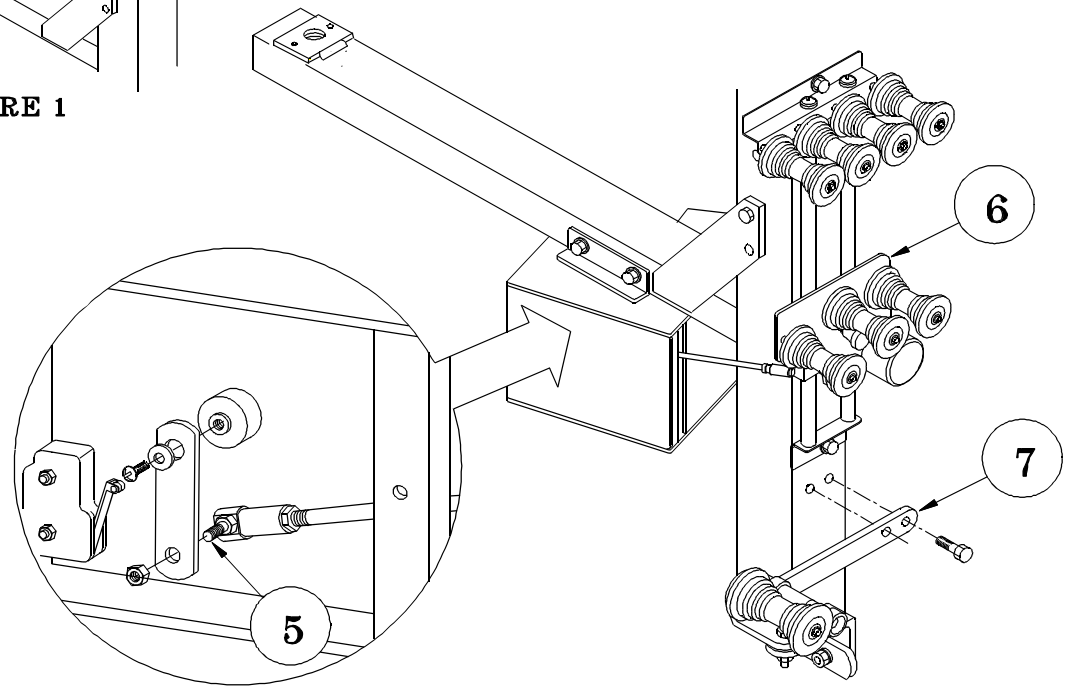

**FIGURE 3, ALPHA VARIAC**

7. Remove the 35mm bottom castor and bracket and install the new 70mm Column Bottom Castor Bracket (1410) and Castor Swivel Assembly , Left (2605). (See note on step 1.)

8. Replace the 35mm Control Plate with the new 70mm Control Plate.

### **SYSTEM OPERATION**

The 70mm Conversion operates in the same manner as the 35mm system except for the threading of the film through the Control Plate (See Fig. 4) and the Take-Up (See Fig. 5). Use the new 70mm Pulleys installed near the top of the Column and at the two upper arm mounts for Platter Feed-Out operation. Refer to the 35mm Operation Manual (Alpha Manual #2989) for all other instructions.

Operation and conversion instructions for the Make-Up Table are included with the table and the 35mm/70mm Table Conversion Kit (Manual #1815).

### **SYSTEM CONVERSION FROM 35mm TO 70mm.**

1. Remove the 35mm Control Plates by grasping two of the small rollers on opposite sides of the control plate and pulling straight up. Install the 70mm Control Plates by inserting the plug-in hub on the bottom of the control plate into the disk spindle and gently rotating the control plate until the locating pin on the hub lines up with the slot. The control plate should drop easily into place.

2. Install the removable Take-Up Weight (See Fig. 5, page 4).

3. Remove the five 35mm Castor Swivel Assemblies (3 located on side of the column, 1 at the upper column bracket and 1 on the lower column bracket beneath the Take-Up).

*NOTE:* Readjust all swivel assemblies after the initial thread-up and before running the first program. Be sure that the height of the swivel rollers is adjusted so that the film contacts the platter disk correctly (see operation manual). Failure to do so may result in film damage.

### **SYSTEM CONVERSION FROM 70mm TO 35mm FILM**

1.) Remove the 70mm Control Plate and install the 35mm Control Plates. (See step 1 above.)

2.) Remove the Take-Up Weight. (See Fig. 5, page 4).

3.) Remove the 70mm Castor Swivel Assemblies and replace with the 35mm Castor Swivel Assemblies. (See step 3 above.)

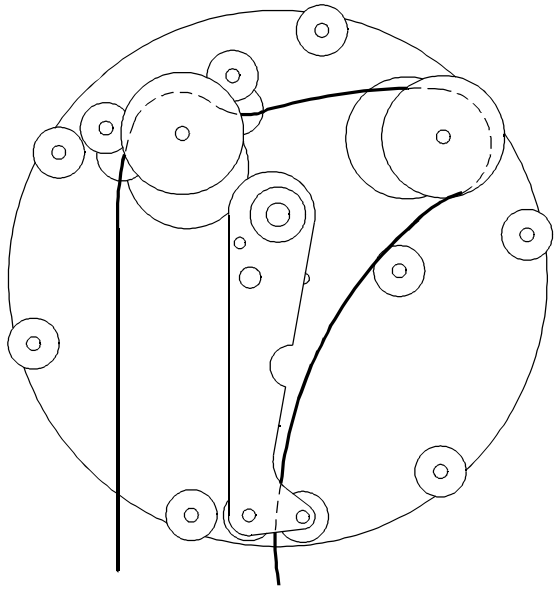

FILM OUT      FILM IN  
**FIGURE 4**

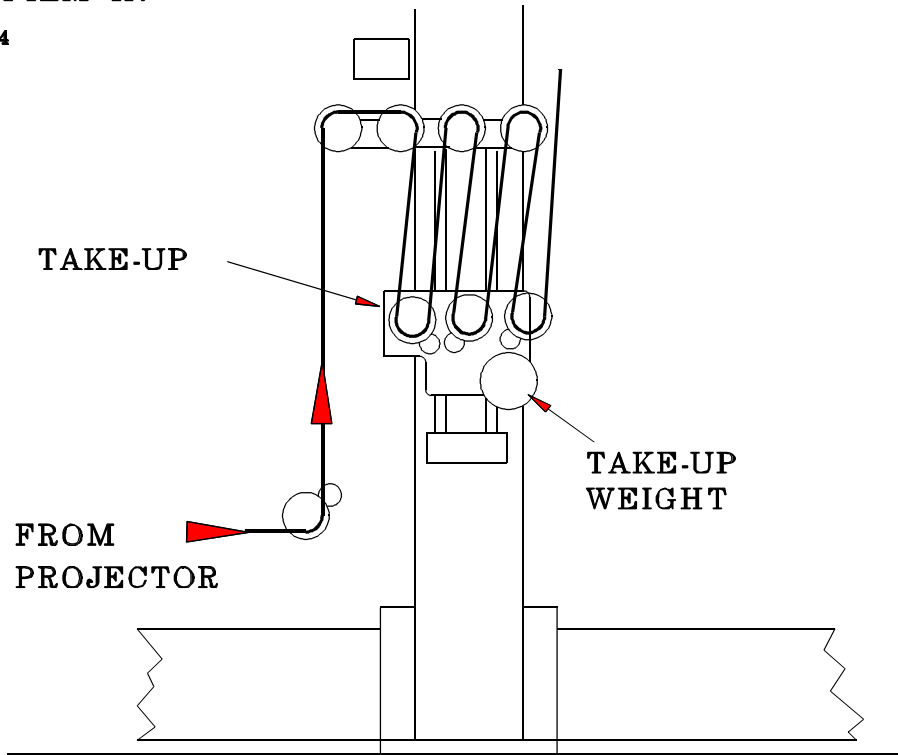

**FIGURE 5**

# IMPORTANT SAFETY INSTRUCTIONS

1. Read and understand all instructions before using.
2. Close supervision is necessary when any appliance is used by or near children. Do not leave appliance unattended while in use.
3. Do not operate appliance with a damaged cord or if the appliance has been dropped or damaged-until it has been examined by a qualified serviceman.
4. Position the cord so that it will not be tripped over, pulled or contact hot surfaces.
5. If an extension cord is necessary, a cord with a current rating at least equal to that of the appliance should be used. Cords rated for less amperage than the appliance may overheat.
6. Always unplug appliance from electrical outlet before cleaning and servicing and when not in use. Never yank cord to pull plug from outlet. Grasp plug and pull to disconnect.
7. To reduce the risk of electric shock, do not use this product near water or other liquids.
8. To reduce the risk of electric shock, do not disassemble this appliance. Refer all work to a qualified serviceman when service or repair work is required. Incorrect reassembly can cause electric shock when the appliance is used subsequently.
9. The use of an accessory attachment not recommended by the manufacturer may cause a risk of fire, electric shock or injury to persons.
10. Connect this appliance to a grounded outlet.
11. Disconnect this unit from It's source of supply before replacing the lamps.

**SAVE THESE INSTRUCTIONS**