

FILM-TECH

THE INFORMATION CONTAINED IN THIS ADOBE ACROBAT PDF FILE IS PROVIDED AT YOUR OWN RISK AND GOOD JUDGMENT.

THESE MANUALS ARE DESIGNED TO FACILITATE THE EXCHANGE OF INFORMATION RELATED TO CINEMA PROJECTION AND FILM HANDLING, WITH NO WARRANTIES NOR OBLIGATIONS FROM THE AUTHORS, FOR QUALIFIED FIELD SERVICE ENGINEERS.

IF YOU ARE NOT A QUALIFIED TECHNICIAN, PLEASE MAKE NO ADJUSTMENTS TO ANYTHING YOU MAY READ ABOUT IN THESE ADOBE MANUAL DOWNLOADS.

WWW.FILM-TECH.COM



AUTHORIZED DISTRIBUTOR:
JARCO INDUSTRIES
TOLL FREE ORDERING 800-458-7578
WWW.CONCESSIONSTANDS.COM

Part No. 74103
Revised June 1996

Jumbo 360

Instruction Manual

Model #2033





 **GOLD MEDAL**®

FUNFOOD EQUIPMENT & SUPPLIES

Cincinnati, OH 45241-4807 USA

SAFETY PRECAUTIONS

	⚠ CAUTION
	This equipment is designed and sold for commercial use only. This equipment is not to be used by the consumer in home use. Do not allow direct contact of this equipment by the public when used in food service locations. Only personnel trained and experienced in the equipment operation may operate this equipment. Carefully read all installation instructions before operating the equipment.

	⚠ WARNING
	Always wear safety glasses when servicing this equipment.

	⚠ WARNING
	To avoid serious burns, do NOT touch the kettle while it is hot.

	⚠ WARNING
	Any alterations to this equipment will void the warranty and may cause a dangerous situation. NEVER make alterations to the equipment. Make sure all machine switches are in the OFF position before plugging the equipment into a receptacle.

	⚠ DANGER
	Machine must be properly grounded to prevent electrical shock to personnel. Do NOT immerse the kettle, warmer, or any other part of this equipment in water. Always unplug the equipment before cleaning or servicing.

NOTE

The information, specifications and illustrations contained in this manual represent the latest data available at time of publication. Right is reserved to make changes as required at the discretion of Gold Medal Products Company without notice.

This instruction booklet is very thorough and complete. Please take the time to read this entire booklet before attempting to operate the appliance.

Your Jumbo 360 Commercial Popper is the finest 36 Oz. gas popper ever built. No expense has been spared to give you a long lasting unit to withstand the heavy loads of commercial popping. The special alloy steel kettle is extra heavy to prevent burnouts or warping, and is made from excellent heat conducting steel. Your Jumbo 360 has an extra heavy duty motor equipped with an extra fan and air tunnel to direct cooling over the motor at all times allowing the motor to run cooler under heavier popping conditions.

UNPACKING AND ASSEMBLY

After unpacking your Jumbo 360, set it on a counter where you intend to use it and remove all the tape. Make sure clearances around and overhead the appliance comply with the marking on the data plate for the location you have selected. Attach the counterweight assembly as per Drawing C-1737, Sheet 3.

INSTALLATION

When installing your new Jumbo 360 Commercial Gas Popper, you must conform with local codes, or in the absence of local codes, with the National Fuel Code, ANSI Z223.1-1980.

	⚠ DANGER
	<p>Gas is safe when used properly, but can be very dangerous when used improperly. We suggest that installation be carefully made by only a qualified service person. Gas companies have competent service people to provide safe installation.</p>

When selecting a location for your new Jumbo 360, pay close attention to the installation clearances. The MINIMUM clearance for the sides opposite the dump handle is 10 inches; the MINIMUM side clearance for the other sides is 30 inches. The MINIMUM overhead clearance is 30 inches.

The appliance and its individual shutoff valve must be disconnected from the gas supply piping during pressure testing of that system at pressures greater than 0.5 psig (3.45 kPa).

During any pressure testing of the gas supply piping system at pressures equal to or less than 0.5 psig (3.45 kPa), the appliance must be isolated from the gas supply piping system by closing its individual manual shutoff valve.

This unit must be grounded in accordance with local codes; or, in the absence of local codes, with the National Electric Code - ANSI/NFPA No. 70-1981. When wiring your new Jumbo 360, refer to the wiring diagram located inside of the cabinet and in this Instruction Manual (Drawing No. A-1822).

After installation all gas connections must be checked for leaks with a soap solution. When gas connection is complete, wire the unit to the power source which will carry the current specified on the unit's data plate.

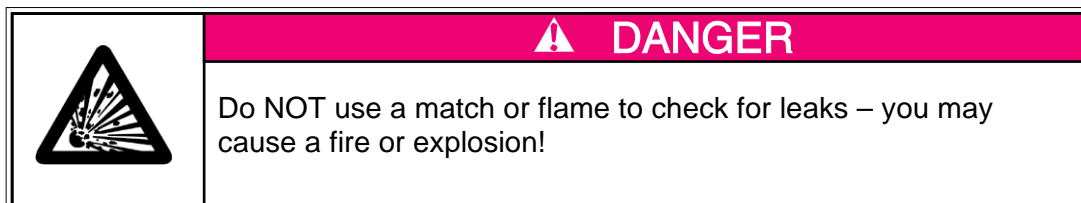

TYPES OF GAS

The nameplate is marked at the factory to indicate the type of gas the appliance uses: either, LP or propane for Liquefied Petroleum Gas, or NAT or NG for Natural Gas. If necessary the unit can be altered to change fuels, but we suggest a qualified service person do the work. Please have your service person refer to the *Maintenance and Repair* section of this manual.

ALTITUDE RANGE

The factory has sized the burner orifices for an elevation up to 2000 feet above sea level. For high altitude operation, please contact Gold Medal Engineering for the proper orifice size.

GAS PRESSURE

We have determined that optimum popping results occur when the gas pressure is adequate. For LP gas, we recommend a pressure setting of 10 inches water column (6 oz. per square inch); and, for Natural Gas, 4 inches water column (2 oz. per square inch). The pressure is measured at the appliance while the main burner is ignited. A pressure regulator is supplied to deliver the optimum pressure for both types of gas when the unit is changed from the original factory specification. Follow the instructions in the *Maintenance and Repair* section. Adequate gas requirements are maintained by properly sized piping. Be sure the piping is properly sized to supply the needed pressure.

LIGHTING AND SHUTDOWN INSTRUCTIONS

Another fine feature of your Jumbo 360 is the Manual Spark Igniter. You can throw away the matches, straws or other makeshift contraptions you have had to use in the past. You simply depress the red button on the unit and it internally releases and creates a spark at your pilot light. If gas is present a flame will result. On a new installation (or, if you run out of propane) it is possible to have air in the lines. Lines may be purged by loosening a connection at some point. This must be done very carefully by the installation professional. Time must be allowed for gas to dissipate before attempting to light, normally about 5 minutes.

1. Turn the handle of the gas safety valve to the "PILOT" position.
2. Push down the red reset button, depress the spark igniter and repeat until the pilot lights. Hold the red reset button for about 30-45 seconds or until the pilot remains burning when the button is released.
3. Turn the main handle to the "ON" position. The main burner should now ignite from the pilot burner.
4. If you want to turn off both the pilot and the main burner, pull lock on safety and turn to the "OFF" position.

	⚠ WARNING
	If pilot is turned out, a five minute shut down period is required before attempting to relight.

AIR ADJUSTMENT ON BURNER

After your main burner has been lit according to the directions above, you might have to make some air adjustment in order to get the best flame. The Air Adjustment Cap should be turned to give more or less air. A blue flame is desired for optimum heat.

TO POP POPCORN

Turn the main burner on and put oil in the kettle. You can let oil heat slightly before adding the popcorn and salt. We recommend 36 ounces of popcorn, 12 ounces of high quality coconut oil, and Flavacol salt to give the best results. A good measure of oil and Flavacol is the secret to top quality popcorn; popcorn that brings you more repeated sales. If you are in a commercial pre-pop operation, this is even more important; good quality pre-pop commands a higher price. To your customer, it is well worth the slight extra price.

Yes, you can put more corn into the kettle, but this will lengthen the popping cycle and your overall production will decrease. You can make smaller batches, if necessary, but always use a corn to oil ration of 3:1. When using a smaller batch you might turn the burner down slightly to prevent it from getting too hot.



IF THE FLAME GOES OUT

A 5 minute shutdown period is required before attempting to relight.

1. Check to see if you are out of gas.
2. Check to see if the thermocouple is in the proper position.

	⚠ WARNING
	At no time during a power failure is there to be an attempt to operate this unit. In the case that a power failure occurs during operation, the gas supply is to be turned OFF until power failure has subsided. Then, and only then, should a relight attempt be made per the <i>Lighting and Shutdown Instructions</i> .

MAINTENANCE INSTRUCTIONS

	<p style="text-align: center;">⚠ CAUTION</p> <p>THE FOLLOWING SECTIONS OF THIS MANUAL ARE INTENDED ONLY FOR QUALIFIED SERVICE PERSONNEL WHO ARE FAMILIAR WITH ELECTRICAL EQUIPMENT. THESE ARE NOT INTENDED FOR THE OPERATOR.</p>
	<p style="text-align: center;">⚠ WARNING</p> <p>Adequate eye protection must be used when servicing this equipment to prevent the possibility of injury.</p>
	<p style="text-align: center;">⚠ DANGER</p> <p>Do NOT immerse the equipment in water. Unplug your machine before servicing.</p>

The entire motor and gear drive assembly can be removed for cleaning and lubrication. Refer to drawing # C-1737 (sheets 1, 2 and 3).

1. Disconnect the power supply at the fuse box or breaker.
2. Remove service door (part # 74054).
3. Disconnect motor wires at plastic connector.
4. Pull the quick disconnect pin (part # 74011).
5. Lift out lower agitator shaft assembly (part # 74008).
6. Slide gear and drive assembly out for lubrication.
7. Re-assemble in reverse order of removal.

LUBRICATION REQUIREMENTS

DRIVE MOTOR

Relubricate yearly by putting 30 drops of SAE 10 motor oil into oil holes. **CAUTION:** Do NOT over oil. For intermittent use relubricate every 2 years; for occasional use, every 5 years.

GEAR BOX

The gear box is filled with multi purpose gear lubricant (SAE 80-90) to a level $\frac{1}{16}$ " below the top of the street ell on the side. To check the level, unscrew the pipe plug in the elbow. The lubricant should be checked periodically and maintained to the proper level.

FILLING THE GEAR BOX

Remove the pipe plug from the elbow on the side and pour oil into the top fill port until it reaches the proper level. Replace the plug.

GAS CONVERSION

1. Disconnect the power supply at the fuse box or breaker.
2. Turn off the gas supply.
3. Refer to drawing number C-1737 Sheet 4 of 4.
4. Remove elbow fitting (part # 72037) from the main burner. Replace the main burner spud orifice with appropriate part # for the intended type of gas.
 - A. Part # 74025 for LP gas.
 - B. Part # 74026 for natural gas.
5. Replace the pilot burner orifice with the appropriate part number for the intended type of gas.
 - Pilot Burner Part No. 74028 with #74034
 - A. Part No. 74029 (.011 Dia. Holes) for "LP" Gas.
 - B. Part No. 74531 (.023 Dia. Holes) for Natural Gas. ("NAT")
 - Pilot Burner Part No. 74032
 - A. Part No. 74050 (.011 Dia. Holes) for "LP" Gas.
 - B. Part No. 74033 (.018 Dia. Holes) for Natural Gas. ("NAT")
6. Remove the hex cap on the pressure regulator and position the appropriate end of the red plug down. "LP" for Liquefied Petroleum Gas, and "NAT" for Natural Gas. Replace the hex cap.
7. **CAUTION:** Orifice hoods and spuds must be screwed tight when LP gas is used.
8. Turn on gas supply and leak test all connections with a soap solution.
9. Turn on main power.

ORDERING SPARE PARTS

1. Identify the desired part by checking it against the photos, illustrations, and/or the parts list.
2. When ordering, please include part number, part name, and quantity desired.
3. Please include your model name and machine serial number (located on the machine nameplate) with your order.
4. Address all parts orders to:

Jarco Industries

order toll free 800-458-7578

or order online at www.concessionstands.com

BASO VALVE INFORMATION

INSTRUCTIONS

**BASO®
VALVE
SERIES
B843
B843G
C843**

INSTALLATION

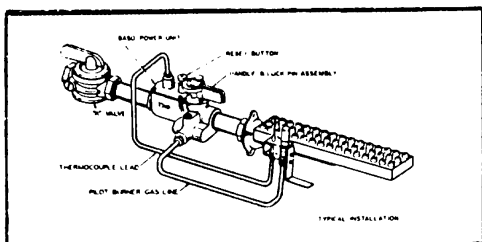

The above series Baso valves may be mounted in any convenient position.

When installing the valve on the manifold, be sure that the gas flow through the body is in the proper direction as indicated on the body. Do not exert pressure on any part of the valve except on

wrench flats at inlet and outlet.

The first two or three threads of manifold pipes or connecting nipples and of valve inlet and outlet should be doped with a good non-galling thread compound. Take care to see that excess compound does not work into valve and get onto valve seats. Threads of pipes and nipples must be smooth and free of tears and burrs.

Attach thermocouple to pilot burner firmly and screw terminal end to power unit terminal on valve. Be sure that this electrical connection is tight and clean.

Attach pilot gas line to pilot burner fitting and to opening of pilot boss on valve or to the "B" valve, if one is used, at the pilot gas outlet.

Check for leaks with a soap solution.

OPERATION

1. Close "A" valve and wait at least five minutes for unburned gas to escape from appliance; then reopen "A" valve.
2. **CAUTION: DO NOT ATTEMPT TO FORCE RESET BUTTON OR HANDLE UNDER ANY CIRCUMSTANCES.** Turn handle to "PILOT" position.
3. Push down reset button and light pilot burner, continuing to hold down reset button 30 to 45 seconds or until pilot remains burning when button is released.
4. Turn handle to "ON". Main burner should now

ignite from pilot burner.

5. If valve is used to throttle main burner, throttle between "ON" and "PILOT" positions only.
6. The valve in "OFF" position shuts off both pilot and main burner gas. To turn off, pull lock button, if valve has one, and turn handle to "OFF".
7. On valves where pilot adjustment is provided, adjust pilot flame by removing slotted pipe plug and turning inner screw to the right to decrease, or to the left to increase pilot burner gas. Replace slotted pipe plug tightly to prevent gas leakage.

SERVICE SUGGESTIONS

Field servicing of this control is limited to replacement of the Baso power unit assembly and handle assembly, and to cleaning and greasing the plug valve. After a replacement, check for leaks with a soap solution. See "OPERATION" for relighting pilot burner.

TO REMOVE POWER UNIT ASSEMBLY:

1. Close "A" valve. Disconnect thermocouple lead connector at power unit assembly.
2. Remove screws.
3. Turn handle to "PILOT" position.
4. Push down firmly on reset button with index finger and grip edge of plate with remaining fingers and thumb.
5. While holding down reset button, slide assembly away from handle and lift assembly carefully.
6. Throw away old gasket.

TO INSTALL NEW POWER UNIT ASSEMBLY:

1. See that gasket seat is clean. Allow no dirt particles to fall into valve.
2. Position new gasket on underside of replacement power unit assembly cover plate. Make sure that all holes line up with the screw holes in the plate.
3. While holding down reset button with index finger, place power unit assembly in valve with leather disc pointing toward valve handle. Hold alignment by inserting screw through two holes above valve inlet.
4. Start remaining screws down through cover plate turning down all screws evenly, proceeding diagonally and laterally until screws are driven home with as nearly the same pressure as possible.
5. Open "A" valve.

BASO VALVE INFORMATION (continued)

TO CLEAN AND GREASE PLUG VALVE:

1. Close "A" valve. Remove handle set screw and lift off handle.
2. Remove cover plate screws while maintaining downward pressure on cover plate.
3. Lift off cover plate, washer and spring, and pull out plug.
4. Clean plug with a soft cloth and petroleum solvent, taking care not to scratch or mar the plug or seat surface.
5. Grease surface of plug lightly and evenly with Baso Div., #341 gas valve grease or equivalent.
6. Return plug to seat and turn back and forth two or three times and remove from body.
7. Without touching plug surface, clean excess grease out of valve ports of plug and body, and return plug to seat. Reassemble spring, washer, cover plate, cover plate screws, handle, and handle set screw in that order. Open "A" valve.

PILOT SERVICE IN THE EVENT OF PILOT FLAME FAILURE

1. If pilot flame burns yellow, clean pilot orifice and pilot burner to insure a steady, blue flame. The orifice can be cleaned by washing in a solvent such as trichloroethylene and/or blowing out.
2. Flame must surround thermocouple tip for approximately $\frac{1}{2}$ inch.
3. Thermocouple lead connections must be tight, clean, and free of grease. This is an electrical connection.

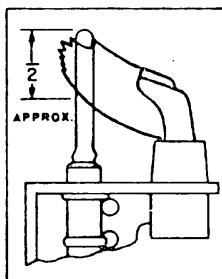

Check millivoltage output of the thermocouple and milliamp dropout range of the Baso power unit to see that they meet the values given in Table I and Table II. Step-by-step procedures for these checks are included with Baso Test Kit No. 120.

TABLE I. THERMOCOUPLE OUTPUT

Thermocouple Lead Type	Turn Down	MV Range	
		Normal	Not Less Than
80, 88D	4 MV	20-25	15
87D	4 MV	30-35	17

TABLE II. DROPOUT RANGE

Model No.	Set Switch At	MA Range of Power Unit Assy.		Thermocouple Lead Type and Lengths
		Low	High	
B843 C843	300 MA	100	300	No. 80 or No. 88 up to 48" Incl. No. 87 49" to 72" Incl.
X5 Power Units for above	300 MA	60	200	No. 37 73" to 144" Incl.
X6 Power Units for above	300 MA	50	145	No. 37 145" to 240" Incl.
B843G	300 MA	50	150	No. 80 or No. 88 up to 48" Incl. No. 87 49" to 72" Incl.

CAUTION: DO NOT LIFT UP ON HANDLE OF CONTROL WHILE PRESSING DOWN RESET BUTTON.

REPLACEMENT PARTS

MODEL NUMBER	† BASO POWER UNIT ASSEMBLY	HANDLE ASSEMBLY
B843-3	801-117	R54149-1
B843-43	801-117	R54149-1
B843-100	801-117	R54149-2
C843-3	801-117	R54149-5
B843G-3	801-118	R54149-1
B843-101	801-117	R54149-2

*ANY ATTEMPT TO REPAIR THIS ASSEMBLY
VOIDS THE MANUFACTURER'S GUARANTEE.

† WHEN MODEL NUMBER ENDS IN X5 OR X6 ORDER
REPLACEMENT NUMBER ENDING IN X5 OR X6.

BASO PRODUCTS DIVISION
PENN CONTROLS INC., MILWAUKEE, WI. 53215

GAS INFORMATION

ELECTRICAL SERVICE AND HEAT SOURCE INFORMATION NATURAL AND PROPANE GAS

PILOT BURNER 74028 WITH 74034

"A"	"B"	"C"	"D"	"E"	"F"	"G"	"H"	"I"	"J"
2033BG	115	60	1	3	5.0	PROPANE	2,500	.011	.023
2033NG	115	60	1	3	5.0	NATURAL	1,000	.011	.023
2033EX	230~	50	1	3	2.5	PROPANE	2,500	.011	.023

PILOT BURNER 74032

2033BG	115	60	1	3	5.0	PROPANE	2,500	.010	.018
2033NG	115	60	1	3	5.0	NATURAL	1,000	.010	.018
2033EX	230~	50	1	3	2.5	PROPANE	2,500	.010	.018



**Mfg. By
GOLD MEDAL PRODUCTS CO.
CINCINNATI, OHIO 45214**

MODEL 2033		SERIAL No.		PROD. No. "A"	
"B" VOLTS	"C" Hz	"D" PHASE	"E" WIRE	"F" AMPS	
"G" GAS		"H" BTU / cu. ft.		MFG. DATE	

MANUFACTURERS RECOMMENDED	PROPANE NORMAL ALTITUDE	NATURAL NORMAL ALTITUDE	PROPANE HIGH ALTITUDE	NATURAL HIGH ALTITUDE
ALTITUDE RANGE	0-2000 FEET			
BURNER	# 50	# 36	#	#
	"I"	"J"		
MANIF. PRESS. WATER COL.	10 INCH	4 INCH	10 INCH	4 INCH
RATED INPUT BTU/Hr	33,500	33,500		

GAS-FIRED FOOD SERVICE EQUIPMENT CLASSIFIED BY UNDERWRITERS LABORATORIES INC. IN ACCORDANCE WITH ANSI Z83.14-1980, Z83.14b-1985, GAS COUNTER APPLIANCES.

TESTED FOR USE WITH LIQUID PROPANE AND NATURAL GAS



774H

INTENDED FOR OTHER THAN HOUSEHOLD USE

MINIMUM CLEARANCE FROM COMBUSTIBLE CONSTRUCTION
6 INCHES FROM SIDE, TOP, BACK, AND FRONT
THIS UNIT IS CERTIFIED FOR INSTALLATION ON COMBUSTIBLE COUNTER

PARTS LIST – JUMBO 360 POPPER

Part No.	Description
47146	Two Cup Measure
47682	Measure, 43cc
57058	Corn Measure Cup Assembly
74103	Parts Manual, Jumbo 360
74147	Screw #8-32 x ½" Rd. Hd. Ph.
74631	Label, Do Not Leave Burner
47008	Label, Use Flavacol
47010	Label, Safe Operating Instructions
46544	¼" Faston, #18-16 AWG
46616	#18 Ga. TEW Wire, White
46618	#18 Ga. TEW Wire, Black
46619	#18 Ga. TEW Wire, Green
74128	.093" Dia. Male Pin
74129	.093" Dia. Female Pin
74130	Three Pin Connector
74131	#10 x #18-16 Ring Terminal
74149	Hex Nut, #8-32
74150	Washer, #8 Internal Tooth
74579	.093" Dia. Female Pin
87149	Label, Caution Disconnect
15122	Dowel Pin, ⅜" x ¾"
41072	Oil Seal
41073	Long Bushing
41074	Spacer
41078	Input Shaft & Gear Assembly
41075	Worm Gear Mach.
41077	Input Shaft
41079	Steel, Worm Gear Assembly
41261	Steel, Worm Gear Mach.
74125	Set Screw, ¼-20 x ⅜"
41134	Bushing Crossbar
46566	Spring Pin, ⅛" x ⅞"
74015	Lid Gear Box
74126	Woodruff Key, #5
74136	Hex Head Bolt, #10-24 x ¾"
74575	Tag, Warning LP Gas

JUMBO 360 POPPER - SHEET 1 OF 4

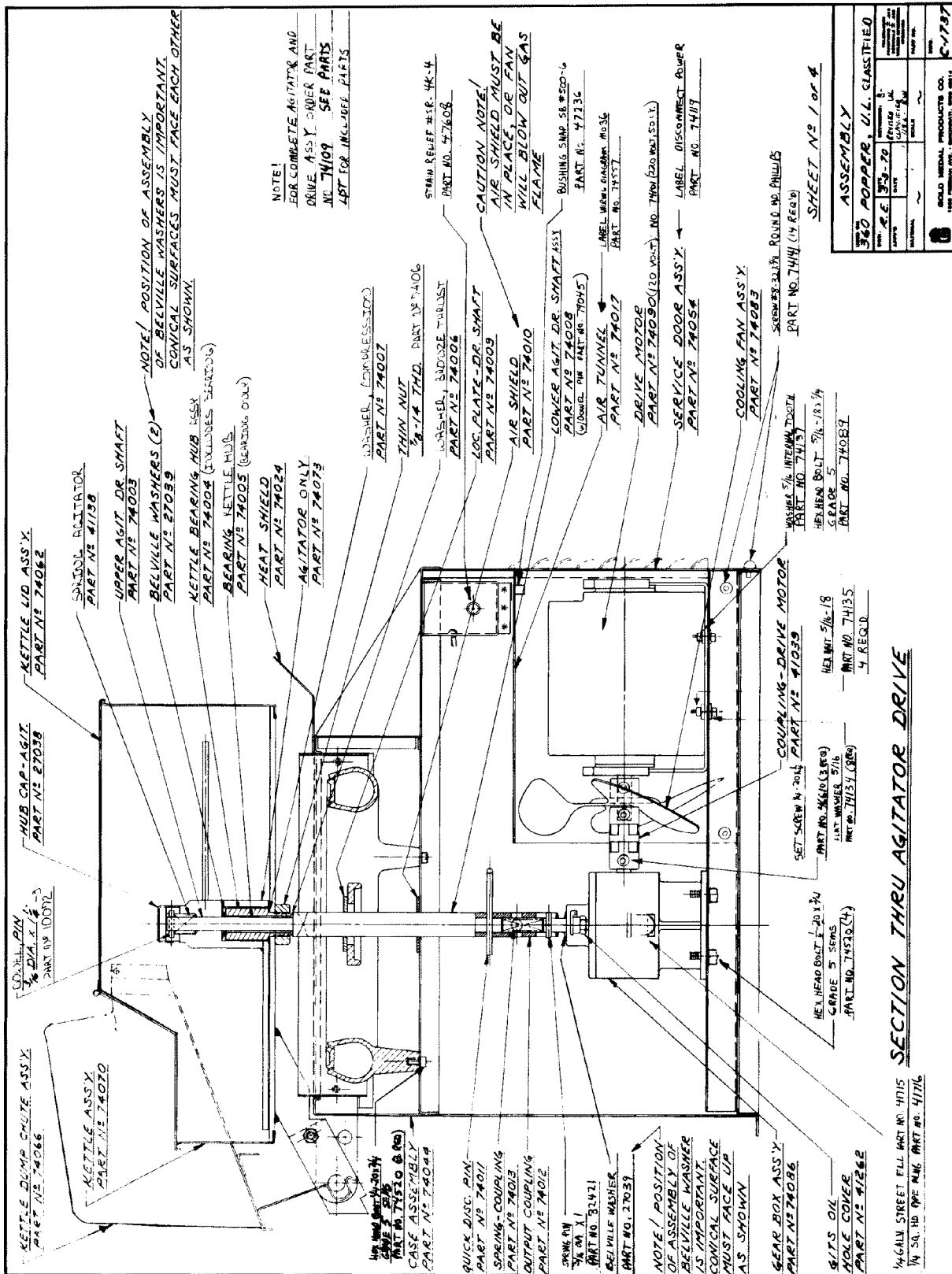

PARTS LIST – JUMBO 360 POPPER, SHEET 1

Part No.	Description
74066	Kettle Dump Chute Assembly
74070	Kettle Only, Jumbo 360
74109	Agitator & Drive Assembly (components listed below)
10072	Dowel Pin, $\frac{3}{16}$ " x 1 $\frac{1}{4}$ "
27038	Hub Cap, Agitator
27039	Belville Washer
41138	Agitator Spring
74003	Upper Agitator Drive Shaft
74004	Kettle Bearing Hub Assembly
74005	Bearing, Kettle Hub
74006	Washer, Bronze Thrust
74007	Washer, Compression
74073	Agitator Assembly
74106	Nut, Hex Jam $\frac{7}{8}$ -14
74074	Hub, Agitator
74075	Lower Stir Rod
74076	Upper Stir Rod
74520	Hex Head Bolt, $\frac{1}{4}$ -20 x $\frac{3}{4}$ "
47608	Strain Relief #SR-4K-4
74010	Air Shield, Agitator Shaft
74024	Heat Shield
74119	Label, Warning Disconnect Power
74044	Case Assembly, Welded Shell
74054	Service Door
27039	Belville Washer
41039	Coupling Drive Motor
46610	Set Screw, $\frac{1}{4}$ -20 x $\frac{1}{4}$ "
47236	Snap Bushing, #SB-500-6
74008	Lower Agitator Shaft Assembly
79045	Dowel Pin, $\frac{5}{16}$ " x 1 $\frac{1}{4}$ "
74012	Output Coupling, MD360
74013	Spring, Output Coupling
74017	Air Tunnel
74084	Fan Blade
74083	Cooling Fan Assembly
74086	Gear Box Assembly
41262	Gits Oil Hole Cover
41715	Galv. Street Ell, $\frac{1}{4}$ " NPT
41716	Galv. Pipe Plug, $\frac{1}{4}$ " NPT
74089	Hex Head Bolt, $\frac{5}{16}$ -18 x $\frac{3}{4}$ "
74111	Motor and Gear Drive Assembly
74090	Motor, Kettle Drive MD360
74134	Flat Washer, $\frac{5}{16}$ "
74135	Hex Nut, $\frac{5}{16}$ -18
74137	Washer, $\frac{3}{16}$ " Internal Tooth
74557	Label, Wiring Diagram MD360
82421	Spring Pin, $\frac{3}{16}$ " x 1"

JUMBO 360 POPPER - SHEET 2 OF 4

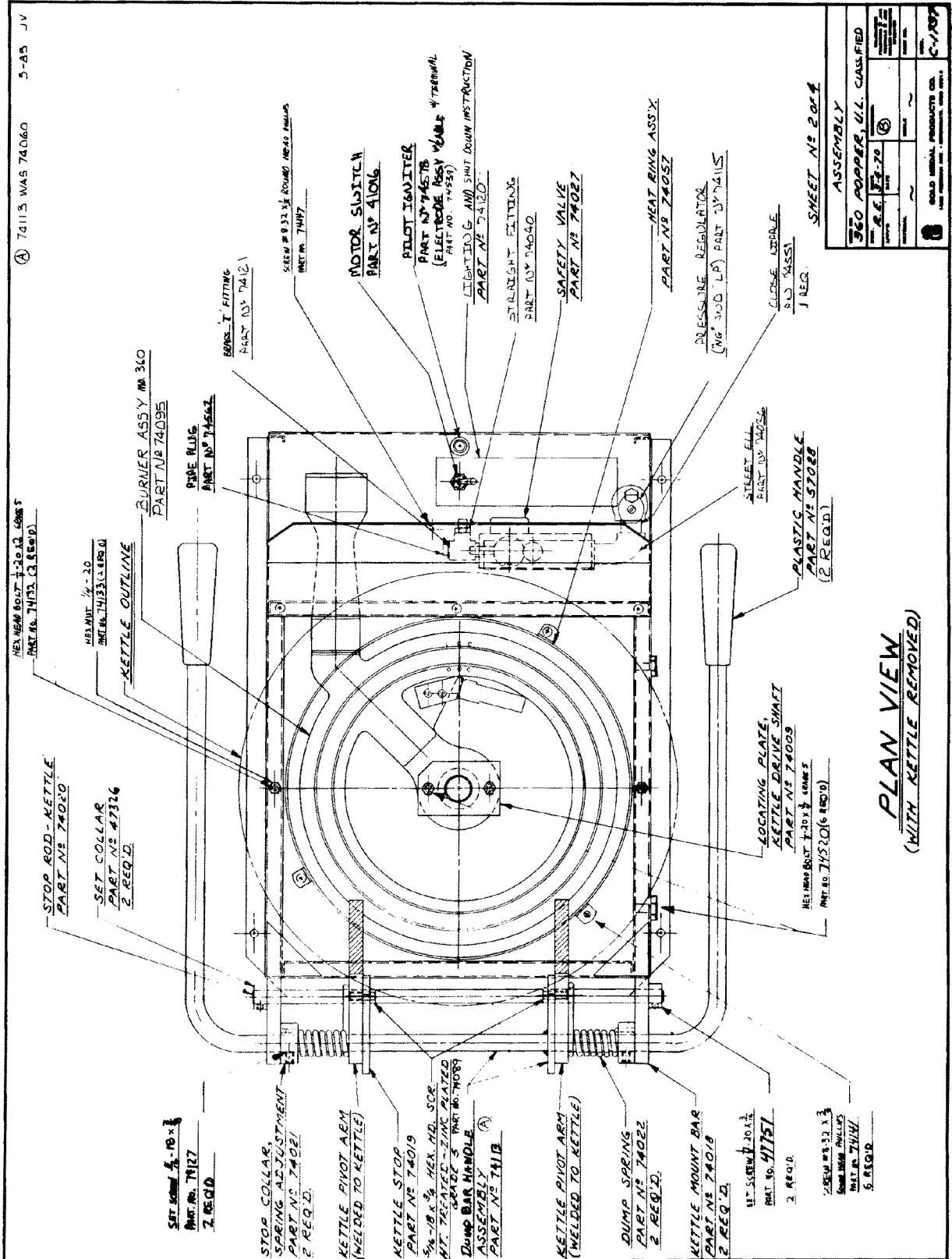

PARTS LIST – JUMBO 360 POPPER, SHEET 2

Part No.	Description
41016	Switch
47326	Set Collar, 1/2" I.D. x 7/8" O.D.
47751	Set Screw, 1/4-20 x 3/16"
57028	Plastic Handle
74009	Locking Plate
74018	Kettle Mount Bar
74019	Kettle Stop
74020	Kettle Stop Rod
74021	Spring Adjustment Collar
74022	Kettle Dump Spring, MD360
74027	Gas Safety Valve
74036	3/8" Brass Street Ell
74040	Straight Fitting
74057	Heat Ring Assembly
74089	Hex Head Bolt, 5/16"-18 x 3/4"
74113	Dump Bar Handle Assembly
74115	Pressure Regulator, NG & LP
74120	Label, Lighting Instrument
74121	T-Fitting, Brass
74127	Set Screw, 5/16-18 x 3/8"
74132	Hex Head Bolt, 1/4-20 x 2"
74133	Hex Head, 1/4-20
74559	3/8" Close Nipple
74562	Brass Pipe Plug, 1/8" NPT
74578	Pilot Igniter w/ Pal Nut
74141	Screw, #8-32 x 3/8" Rd. Hd. Ph.
74520	Hex Head Bolt, 1/4-20 x 3/4"

JUMBO 360 POPPER – SHEET 3 OF 4

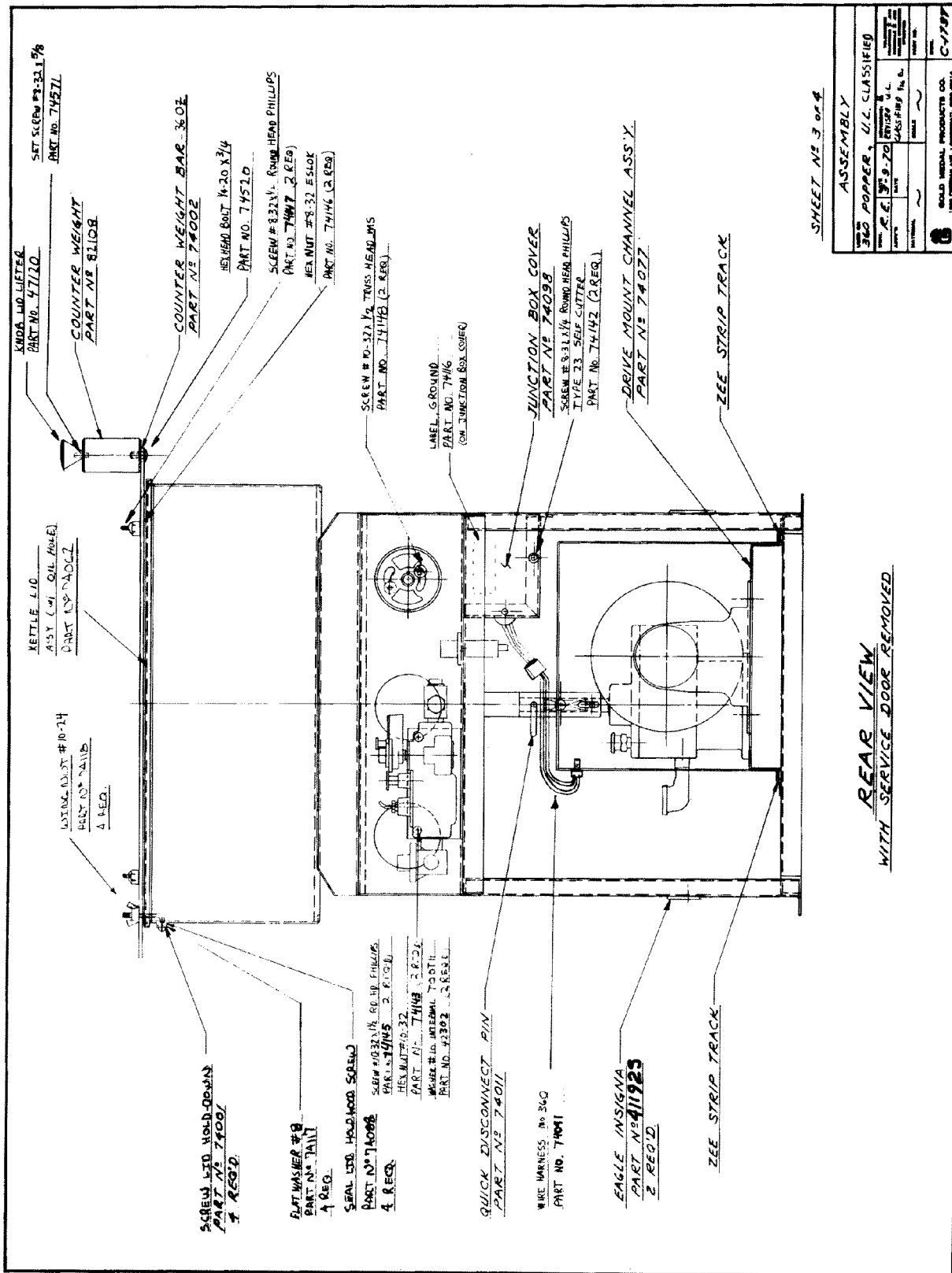

PARTS LIST – JUMBO 360 POPPER, SHEET 3

Part No.	Description
74108	Kettle Assembly, Complete
47120	Knob, Lid Lift
74001	Screw, Lid Hold Down
74002	Counter Weight Bar, 36 Oz.
74062	Kettle Lid Assembly, Oil Hole
74088	Seal, Lid Hold Down Screw
74117	Flat Washer, #8
74118	Wing Nut, #10-24
74146	Hex Nut, #8-32 ESLOK
74571	Set Screw, #8-32 x $\frac{5}{8}$ "
82108	Counter Weight, w/ #8-32 Tap
42302	Washer, #10 Internal Tooth
74098	Junction Box Cover
74116	Label, Ground
74142	Screw, #8-32 x $\frac{1}{4}$ " Rd. Hd. Ph.
74143	Hex Nut, #10-32
74145	Screw, #10-32 x $1\frac{1}{2}$ " Rd. Hd. Ph.
74147	Screw, #8-32 x $1\frac{1}{2}$ " Rd. Hd. Ph.
74148	Screw, #10-32 x $\frac{1}{2}$ " Truss Hd.
74520	Hex Head Bolt, $\frac{1}{4}$ -20 x $\frac{3}{4}$ "
74011	Pin, Quick Dinsconnect
74077	Drive MT. Channel Assembly
74091	Wire Harness, MD360

PARTS LIST – JUMBO 360 POPPER, SHEET 4

Part No.	Description
74037	Elbow, Bulkhead Special
74038	Tube Sleeve
74039	Tube Nut
74025	Spud, Main Burner #53 LP
74026	Spud, Main Burner #40 NG
74028	Pilot Burner
74030	Pilot Orifice, .023" NG (for Use with P/N 74028)
74029	Pilot Orifice, .010" LP (for Use with P/N 74028)
74034	Electrode & Terminal Assembly (for Use with P/N 74028)
74539	Electrode & Terminal Assembly (for Use with P/N 74028 & 74030)
74032	Pilot Burner
74033	Pilot Orifice, .018" NG (for Use with P/N 74032)
74050	Pilot Orifice, .010" LP (for Use with P/N 74032)
74041	Electrode & Terminal Assembly (for Use with P/N 74032)
74094	Pilot Burner Mount Bracket
74095	Burner Assembly, Jumbo 360
74122	¼" Aluminum Tube, 15" Long
74123	5/16" Aluminum Tube, 6" Long
74141	Screw, #8-32 x 3/8" Rd. Hd. Ph.
74144	Screw, #10-32 x ¼" Rd. Hd. Ph.
74031	Elbow Fitting, Basco
57030	Thermocouple
74023	Air Adjustment Cap
41192S	Gold Medal Nameplate SL

ELECTRICAL SCHEMATIC

